

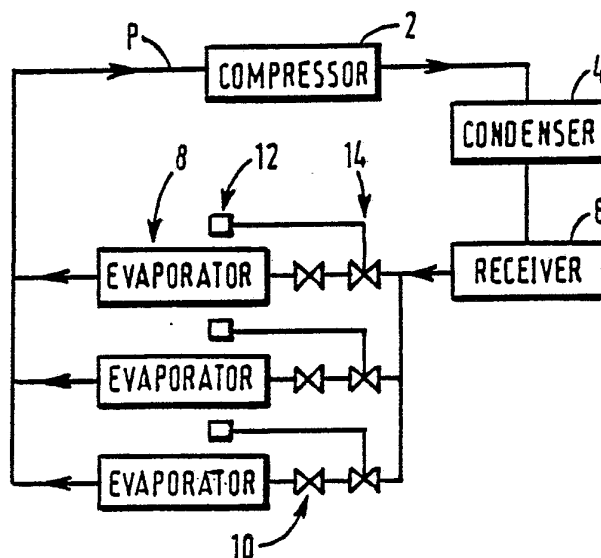

INTERNATIONAL APPLICATION PUBLISHED UNDER THE PATENT COOPERATION TREATY (PCT)

(51) International Patent Classification ⁴ : F25B 49/00, 5/00	A1	(11) International Publication Number: WO 88/ 06703 (43) International Publication Date: 7 September 1988 (07.09.88)
<p>(21) International Application Number: PCT/GB88/00131</p> <p>(22) International Filing Date: 25 February 1988 (25.02.88)</p> <p>(31) Priority Application Numbers: 8704432 8717923</p> <p>(32) Priority Dates: 25 February 1987 (25.02.87) 29 July 1987 (29.07.87)</p> <p>(33) Priority Country: GB</p> <p>(71) Applicant (for all designated States except US): PREST-COLD LIMITED [GB/GB]; Theale, Reading RG7 HAF (GB).</p> <p>(72) Inventors; and (75) Inventors/Applicants (for US only) : LAWRENCE, John, Michael, Walmsley [GB/GB]; Westbrook Manor, Boxford, Newbury, Berkshire (GB). LAWSON, Stuart [GB/GB]; 111 Bath Road, Thatcham, Newbury, Berkshire (GB).</p>	<p>(74) Agent: R.G.C. JENKINS & CO.; 26 Caxton Street, London SW1H 0RJ (GB).</p> <p>(81) Designated States: JP, US.</p> <p>Published <i>With international search report.</i></p>	

(54) Title: REFRIGERATION SYSTEMS



(57) Abstract

A method of controlling a compressor driven vapour compression heat movement system in which a common compressor system (2) heats or cools a plurality of load units (4, 8) and is operated in cycles each of which include a compressor system higher capacity period and a compressor system lower capacity period, characterised in that the lower capacity period is made sufficiently long that when the compressor system (2) is switched to the higher capacity a majority of the load units (4, 8) are demanding heating or cooling and that the higher capacity period is made sufficiently long that when the compressor system (2) is switched to lower capacity one or more of the load units (4, 8) have had their heating or cooling demand satisfied.

FOR THE PURPOSES OF INFORMATION ONLY

Codes used to identify States party to the PCT on the front pages of pamphlets publishing international applications under the PCT.

AT	Austria	FR	France	ML	Mali
AU	Australia	GA	Gabon	MR	Mauritania
BB	Barbados	GB	United Kingdom	MW	Malawi
BE	Belgium	HU	Hungary	NL	Netherlands
BG	Bulgaria	IT	Italy	NO	Norway
BJ	Benin	JP	Japan	RO	Romania
BR	Brazil	KP	Democratic People's Republic of Korea	SD	Sudan
CF	Central African Republic	KR	Republic of Korea	SE	Sweden
CG	Congo	LI	Liechtenstein	SN	Senegal
CH	Switzerland	LK	Sri Lanka	SU	Soviet Union
CM	Cameroon	LU	Luxembourg	TD	Chad
DE	Germany, Federal Republic of	MC	Monaco	TG	Togo
DK	Denmark	MG	Madagascar	US	United States of America
FI	Finland				

REFRIGERATION SYSTEMS

This invention relates to controlling compressor driven vapour compression heat movement systems as used for example in refrigeration and air conditioning for cooling and in heat pump arrangements for heating. Reference will be made primarily to refrigeration systems for explaining the invention in detail.

Figure 1, which will be described in more detail below, shows a typical refrigeration system in which there are three refrigerated food cabinets. Two graphs in Figure 2 illustrate two alternative known modes of controlling such a system. As will also be explained in more detail below, the mode illustrated in the left-hand graph permits the compressor inlet pressure to fall to extremely low values on occasions, and on these occasions the system is operating very inefficiently (consuming excessive power) and removing moisture excessively from food stored in the cabinets. The mode shown in the right-hand graph avoids these problems but on occasions may result in the compressor being switched on and off unacceptably often. It is of course desirable that the system should run as

- 2 -

efficiently as possible so as to minimise its power consumption, and due to limitations in the physical design of compressors, they are given by the manufacturers a rating as to the maximum frequency with which they can be turned on without unacceptably shortening their requirements for servicing and repair. Typical ratings would lie between about six and ten starts per hour.

The invention aims to provide an improved method of controlling a compressor driven heat movement system which enables the system to be run particularly efficiently, while rarely if ever exceeding the starts per hour rating of the compressor.

More particularly, the invention provides a method of controlling a compressor driven vapour compression heat movement system in which a common compressor system heats or cools a plurality of load units (e.g refrigerated cabinets, air-conditioning units or heat pump output units) and is operated in cycles each of which include a compressor system higher capacity period and a compressor system lower capacity period, characterised in that the lower capacity period is made sufficiently long that when the compressor system is switched to the higher capacity a majority of the load units are demanding heating or cooling and that the higher capacity period is made sufficiently long that when the compressor system is switched to lower

- 3 -

capacity one or more of the load units have had their heating or cooling demand satisfied.

The compressor system involved can be a single compressor as in the embodiment which will be described in detail below. In that event its higher capacity mode will be when the compressor is running and its lower capacity mode will be when it is not running during which period of course its capacity is actually zero. However, the invention can also be applied where the compressor system includes a plurality of compressors. Then, in the higher capacity mode some of the compressors are running and in the lower capacity mode a lesser fixed number, which may be zero, are running. For example, it may be desirable to have one compressor, which may be relatively small, which always runs so as to prevent liquid refrigerant accumulating in the inlet route to a main compressor, which is switched on and off.

The low capacity period may be controlled so as to be sufficiently long that when the compressor system is switched to higher capacity a majority of the load units are demanding heating or cooling or, where the operating conditions are sufficiently predictable, the low capacity period may be fixed at a sufficiently long value to ensure that the same condition is met. In the case where the low capacity period is controlled, the control may be exercised

- 4 -

in response to various different sensed characteristics and these will be referred to in more detail below.

In one embodiment, the length of the lower capacity period is controlled in dependence upon the length of the preceding higher capacity period.

So far as concerns making the higher capacity period sufficiently long that when the compressor is switched to low capacity at least some of the load units have had their demand satisfied, preferably this will comprise sensing a variable which represents the load on the compressor system and terminating the higher capacity period when the sensed variable indicates that the load on the compressor system is falling.

Generally, in operating a control method in accordance with the invention for a cooling system, because a majority of the load units are demanding cooling when the compressor is brought on, there will be a substantial period of time during which the majority of the load units will continue to require cooling and therefore there will be a substantial flow of refrigerant through the system and the inlet pressure of the compressor system, and hence the temperature in the evaporators of the load units, will remain at a reasonably constant level so long as this situation prevails. This may conveniently be referred to as a plateau in the load on the compressor system and also

- 5 -

in the inlet pressure against time curve. Furthermore, the method of the invention involves turning the compressor system off when one or more of the load units have had their cooling demand satisfied i.e. not very long after the pressure has started to fall from the plateau following one or more of the load units ceasing to take refrigerant flow because it is no longer demanding cooling.

Consequently, when a method in accordance with the invention is used, most of the heat transfer from the load units occurs in the vicinity of the plateau level of inlet pressure and evaporator temperature and it will become apparent that this means the system is operating primarily above the band $P_{off}-P_{on}$ of the prior art system of the left hand side of Figure 2, and hence is operating more efficiently in terms of energy consumed per unit of refrigeration or cooling achieved.

Various variables may be sensed to indicate the load on the compressor system and these will be described in more detail below. The higher capacity period may be terminated when the sensed variable reaches a set point value.

It has previously been mentioned that when operating a control method in accordance with the invention the compressor inlet (or in the case of a heat pump system, the outlet) pressure variation will exhibit a plateau during

- 6 -

the higher capacity period. Preferably, the invention further comprises sensing the occurrence of a substantially constant level (or "plateau") of load on the compressor system during its higher capacity period and automatically adjusting the set point value to a value which would represent a load level below said substantially constant level.

For example, in a cooling system the set point value may be automatically adjusted during each cycle to lie at 80% of the plateau level measured in terms of absolute value of the compressor inlet pressure, though values between 60% and 90% may be employed depending on the circumstances. A "substantially constant level" may be defined for the above purpose as the pressure varying by less than 10% over a significant period (e.g between 30 and 60 seconds) of time. Also, if a variable other than pressure is sensed, its set point value may need to be set at a different percentage of the plateau value in order to achieved the desired percentage for the pressure level itself.

This preferred feature prevents the occurrence of problems which may otherwise arise as a consequence of the fact that the level of the plateau will not necessarily be the same during each higher capacity period, but may vary from cycle to cycle or drift over a substantial period of

- 7 -

time due to various types of change in operating conditions. For example, in a single compressor system where the load units are refrigerated cabinets, the plateau will occur at a lower value when a number of cabinets are taken out of service, as sometimes happens in practice. If the set point were fixed, this could result in the compressor being switched off before the plateau level is reached in which case adequate cooling of the remaining cabinets would not be achieved. Inaccurate manual setting of the set point pressure could have the same effect. Drift may also occur in the characteristics of pressure transducers and this could result in undesirable shift of the effective set point in a system where the set point is ostensibly fixed. Also, the different operating conditions encountered in winter as compared with summer, the natural plateau level being higher in summer than it would be in winter, means that for uniform operation throughout the seasons a lower set point level should be used in winter than in summer. The preferred feature of automatic adjustment of set point level in response to plateau level mitigates the problems just referred to.

In order that the invention may be more clearly understood, embodiments thereof will now be described with reference to the accompanying diagrammatic drawings in which:

Figure 1 is a simplified illustration of a typical compressor driven refrigeration system;

Figure 2 shows in a simplified form the relationship between compressor inlet pressure and time for two different known methods of controlling such a system;

Figure 3 shows in detail a control cycle in accordance with the invention plus other information useful in understanding the invention;

Figure 4 shows diagrammatically several cycles of a method of control in accordance with the invention;

Figure 5 shows the components for carrying out the method of Figures 3 and 4;

Figure 6 is a flow chart showing the steps of a control method according to Figures 3 and 4; and

Figure 7 shows the form of a compressor outlet pressure cycle in a heat pump heating system.

The refrigeration system of Figure 1 is typical of systems that might be found in, for example, supermarkets, where a number of refrigeration cabinets need to be kept cold and have their temperatures controlled. There may be any number of cabinets, six or more being typical, but for simplicity the Figure 1 system is shown with three. A compressor 2 feeds compressed gaseous refrigerant to condenser 4 where it is condensed to liquid which flows to a receiver or reservoir 6. From the receiver it flows on three parallel paths through three evaporators (one per cabinet) indicated at 8 and from the evaporators back to

- 9 -

the compressor 2 in gaseous form, the liquid refrigerant having evaporated within the evaporators to produce the cooling effect. In standard manner, expansion valves 10 precede the evaporators 8 and are automatically controlled in known manner so as to maintain correct conditions within the evaporators. Each cabinet is provided with a temperature sensor 12 which exercises thermostatic control over an on/off value 14 for that particular cabinet. Thus, each evaporator only takes liquid refrigerant from the receiver when the temperature of its associated cabinet has risen to such a level that it requires further cooling.

The left-hand graph in Figure 2 illustrates the use of a control method in which the compressor inlet pressure (which is related to the evaporator temperature when refrigerant is boiling in the evaporator) is measured and compared with a set point value P_{off} which is set so low that the pressure will fall below it only when all three evaporators have been turned off by their own thermostatic temperature control systems. Consequently, so long as any one of the evaporators is working, the compressor will be running, but with its inlet pressure varying according to how many evaporators are on. The compressor inlet pressure would be approximately at either level 3, 2 or 1 illu-

- 10 -

strated in Figure 2 according to whether three, two or one evaporators are operating, and would fall to the level 0 only when all the evaporators were turned off, so that it is only in this condition that the compressor itself would be turned off. Pressure then rises until P_{on} is reached, when the compressor is re-started. With such a system, at times when the demand for refrigeration is low, then the compressor inlet pressure is permitted to become very low, and the evaporator temperatures will be correspondingly low, and in these conditions the efficiency of the system is very poor in terms of heat removal per unit of energy input. A further and substantial disadvantage of this method of control is that the very low evaporator temperature causes excessive icing with the attendant inconvenience and cost of having to defrost the cabinets more often whilst, undesirably, the product in them warms up. Another is that certain food products will have moisture removed from them excessively.

These problems are avoided by using a control system which as illustrated in the right-hand graph of Figure 2 has two set point values P_{on} and P_{off} which are set relatively close together and are both quite high. This necessarily prevents the compressor inlet pressure from ever falling to low values but at the same time, when the demand for refrigeration is low, so that the compressor

- 11 -

inlet pressure falls very rapidly when the compressor is on, the operating cycles of the compressor become very short and the start per hour rating of the compressor will be exceeded so that the compressor will be subject to excessive wear and its servicing and repair costs, and the frequent inconvenience of servicing, will be unacceptable.

Reference will now be made to the full line curve in Figure 3 to explain the type of cycle that is repeatedly produced by using a control method in accordance with the invention to control a cooling or refrigeration system such as that shown in Figure 1. At the beginning 16 of the compressor on period of the cycle, the compressor will have been off for some while, any liquid refrigerant in the evaporators of the cabinets will have evaporated to gas and the gas will have warmed up to a greater or lesser degree. In this condition, the compressor inlet pressure bears no particular relationship to the gas temperature. Also at the beginning of the on period, and for reasons described below a majority of the cabinets (preferably at least 75%, for example 5 out of 6) will have their thermostatically controlled valves 14 open i.e. they are demanding cooling. When the compressor is switched on, the pressure initially falls very rapidly as the gas is pumped out of the evaporators. This is indicated by the steeply falling part

- 12 -

18 of the curve in Figure 6. At the point indicated at 20, the expansion valves of the cabinets open and liquid refrigerant starts to flow into the evaporators and to evaporate in them. When the expansion valves have been open for a little while, the rate of evaporation of refrigerant liquid in the evaporators reaches a relatively high level such that the pressure stops falling or falls only gradually, in part 22 of the curve. Because the demand for cooling is high, there will be a total flow of refrigerant through the individual cabinet cooling systems which approaches the maximum amount of flow possible, and consequently the plateau 22 in the compressor inlet pressure will occur at a relatively high level e.g., with refrigerant R502, and with chill (produce temperature $+4^{\circ}\text{C}$) cabinets as a load, at about 2.8 bar gauge pressure. A major part of the refrigeration of the cabinets will occur during this phase of the cycle, and therefore at relatively high efficiency. In contrast, a pump-down control system as illustrated on the left in Figure 2 would typically operate at an average pressure of about 1.8 bar gauge under the same conditions. When using the invention, the plateau would occur at the three-cabinet running level of Figure 2, i.e. at a higher pressure (above say 2.1 bar) than is ever reached by the pump-down system when the latter is running between its P_{on} and P_{off} values. As individual cabinets

- 13 -

reach the temperatures set on their thermostats, their thermostatic valves 14 start to close off, thus limiting the total refrigerant flow in the system, and the pressure starts to fall again as indicated at part 24 of the curve. When the pressure reaches P_{set} , the compressor is turned off at point 26. P_{set} is set (by empirically establishing the typical level of the plateau in a given system, and putting P_{set} to a value slightly lower than that) at such a level that the pressure will not have to drop very far from the plateau before the compressor system is switched off at point 26. Hence only a minority, for example one or two out of six, of the cabinets will have had their cooling demand satisfied at switch-off.

Figure 3 shows a downward continuation of part 24 of the pressure curve to illustrate in more detail how a system operating in accordance with the left-hand side of Figure 2 performs. Typically, P_{off} is set at a relatively low value and the pressure continues to fall to that value along the broken-line part 28 of the curve. P_{off} is set so low that it will not be reached until the thermostatic valves of all the cabinets have closed i.e. the demand for cooling has become zero. The compressor system is then switched off and the pressure rises along part 30 of the curve until a pre-set value P_{on} is reached at which time the pressure starts to fall again as the compressor system

- 14 -

comes into operation, this being along the broken line 32. The result is that the system cycles in the band between P_{off} and P_{on} which lies in a relatively low pressure range and so the system is operating at a correspondingly low average efficiency.

The invention achieves greater efficiency because of the high level of plateau 22.

With the compressor off, the compressor inlet pressure initially rises very rapidly because the expansion valves are open, some of the thermostatic valves are open, and so liquid is entering the evaporators and boiling in them. This is shown at part 34 of the curve and during this phase open thermostatic valves may or may not close. When the pressure reaches a certain value, to which the expansion valve controls have been set, the expansion valves close and the remaining refrigerant in the evaporators boils off during part 36 of the curve. When all the liquid has boiled off, the pressure at the compressor inlet rises only slowly and at a decreasing rate as the gas at that point becomes gradually warmer, this happening along part 38 of the curve.

The off period is controlled as will be described so as to be sufficiently long that at the end of it a majority of the cabinets will once again be demanding cooling.

- 15 -

Before referring to Figure 4 it should be mentioned that, for control purposes, the pressure at the inlet of the compressor only has significance when it is fairly close to the pressure at which refrigerant is boiling in one or more of the evaporators of the system. For this reason, any pressure measurements made at the peak of part 18 of the Figure 3 curve would not be significant. They only become significant at a point shortly after (perhaps five seconds after) the compressor has been switched on, as indicated at 40 in Figure 3, at which time it will be certain that liquid has entered one or more of the evaporators, and that therefore the compressor inlet is approximately at the pressure under which that liquid is boiling therein.

Figure 4 shows the variation of the on and off periods of a compressor controlled by the method of the invention over several cycles. For simplicity only, the pressure rises and falls are shown as straight lines (though in reality they would be Figure 3-type curves), and the pressures at which the compressor is shown being switched on and off in Figure 4 actually represent the points 40 and 26 in Figure 3, in accordance with the explanation just given.

In Figure 4, the compressor is run for a period T_{on} which is terminated when the compressor inlet pressure

- 16 -

reaches the set point P_{set} . The compressor is then turned off for a calculated period of time T_{off} which may be equal for example to four minutes. After the off period, the compressor is turned on again until the inlet pressure has again fallen to P_{set} . The off period of the compressor is derived (as explained below with reference to Figure 6) with reference to the time that it takes for compressor inlet pressure to fall to P_{set} after the compressor has been turned on, this time being taken as a characteristic indicative of the load on the compressor system. If the on period become undesirably short (for example less than two minutes) due to low load, then the subsequent period T_{off} is extended so as to increase the length of the subsequent period T_{on} and hence the length of the next cycle. As well as achieving high efficiency, this also tends to ensure that the total cycle time will be long enough for the number of starts per hour of the compressor rarely if ever to exceed its rated value.

From the above, it can be seen that in accordance with the invention insofar as a fixed set point value is used, only a single set point pressure value has to be set when the system is being installed, and consequently only a single value has to be adjusted in order to adjust the operation of the system.

- 17 -

Figure 5 shows hardware required to operate the control method of Figures 3 and 4, including a compressor inlet pressure sensor 42, an inlet pressure set point device 44, and a source of time pulses 46 all of which feed their outputs to a controller 48. The controller may be a digital controller which operates in accordance with the flow chart shown in Figure 6 and provides an output signal on line 50 which opens and closes a contactor 52 to switch the compressor 2 off and on. The time factor used in controlling the compressor cycles is derived with reference to the time pulses produced by the source 46.

Figure 6 is a flow chart showing the operation of the controller 48 in order to perform the control method of Figures 3 and 4. Initially $T_{\text{off/set}}$ is set to four minutes, the compressor is then started, compressor inlet pressure is compared with P_{set} until they are equal at which point the compressor is stopped, T_{on} is recorded and the compressor off period $T_{\text{off/set}}$ starts to run.

If the read value of T_{on} is greater than two minutes and less than fifteen minutes, the compressor is switched on again when it has been off for four minutes.

If T_{on} is less than the minimum desired value of two minutes, then $T_{\text{off/set}}$ is increased in inverse proportion to the read value of T_{on} , but subject to a maximum of twelve minutes, and during the next operating cycle the compressor

- 18 -

is held off for the new increased period of $T_{\text{off/set}}$. If T_{on} should become greater than fifteen minutes, then $T_{\text{off/set}}$ is reduced in inverse proportion to T_{on} , but subject to a minimum of four minutes, for the next cycle. The programming of the controller 22 (Figure 5) will be arranged, empirically if necessary, such that in the particular system the relationship between the current demand for cooling as indicated by the length of the on period T_{on} in each cycle, and the length of the off period $T_{\text{off/set}}$ as calculated by the algorithm, will result in the majority of the cabinets demanding cooling at the end of the off period.

The lower limit value, in this instance four minutes, for $T_{\text{off/set}}$ sets a lower limit on the frequency with which the compressor can be started and hence protects it against being started at rates beyond its starts per hour rating. The upper limit of twelve minutes on $T_{\text{off/set}}$ avoids the temperatures in the cabinets becoming too high.

Alternatively, instead of the length of the off period being determined by the programming of the controller, the off period may be terminated in response to a sensed characteristics of the load units. When each of the load units includes a thermostat system, the sensed characteristic may be the condition of the thermostat systems and, for example, the off period may then be

- 19 -

terminated when a majority of the load units are demanding cooling as indicated by the conditions of their thermostat systems. Figure 5 shows in chain-dotted lines 56 connections from the three thermostat switches 12 of Figure 1 by means of which the controller is informed of the conditions of the thermostatic switches and hence can be programmed to detect the closure of a majority of them and in response switch on the compressor system via line 24.

In a system which is not subject to major variations in load, it is possible for the off period actually to be fixed at length which can be relied on to allow the majority of the load units to be demanding cooling when the compressor system is switched on, though provision may be made for manual adjustment of the length of the off period in the event that monitoring of the system indicates that the desired pattern of operation is not in practice being achieved.

So far as the on period is concerned, this is simply terminated when one or more of the load units have ceased to demand cooling, i.e. not very long after the compressor system inlet pressure has dropped from the plateau 22, by appropriately setting the value P_{set} .

However, other variables may be sensed in order to detect the falling load on the compressor system which is indicative of the plateau region having been passed. When

- 20 -

the compressor system is electrically powered, the current consumption, power consumption and power factor of the motor or motors will all be reduced as the load on the system falls from the plateau and hence, as illustrated in Figure 5, a sensing unit 58 may be associated with the power supply to the compressor motor to sense current consumption, power consumption, or power factor. Suitable sensing units are readily available and therefore need not be further described. The output from sensing unit 58 is sent by line 60 to the controller 48, where it will be compared with the output of the set point device 44 to detect when the load, falling from its plateau level, reaches the set point value. Of course, the set point device 44 will be arranged to deliver a set point signal indicative not of a set point pressure, but of a set point current consumption, power consumption or power factor value.

It will be evident that the lengths of the on period and the off period may be determined independently of each other by separate systems so long as those systems are compatible with each other.

It has been mentioned that it is advantageous to vary P_{set} , or whatever alternative set point value may be employed, automatically in response to the level at which the plateau 22 occurs, because although the plateau 22 will necessarily occur at a relatively high level owing to the

- 21 -

high load existing at the beginning of the on period, its exact level will vary according to operating conditions at the time. To achieve this, the controller 48 may be programmed so as to monitor a variable indicative of load, for example compressor inlet pressure from pressure sensor 42, the number of thermostatic valves open as indicated on lines 56, or one of the electrical parameters of the power supply as indicated by unit 58, to recognise when that measured variable does not change by more than 10%, or preferably 5%, during a predetermined period of time, and to treat the detection of that occurrence as an indication that the plateau level 22 is then occurring. It can further be programmed to then provide on line 62 a signal effective to adjust the set point device 18 so that it will give a set point output value to the controller equal to, for example, 80% of the measured value in absolute units of the plateau level.

In certain installations, there may be a small minority of load units which warm up more quickly, or cool more slowly, than the rest. In that event, the controller 48 may be programmed to operate a modified control method in which, instead of turning the compressor off as soon as the 80% (of plateau) level is reached, the compressor is held on until either a lower, e.g. 50%, level is reached or until a further predetermined time (e.g. one minute) has

- 22 -

elapsed, whichever occurs sooner. On occasions, when the unit or units which tend to run warmer do not need extra cooling, they will hardly get any because the pressure will fall rapidly from the 80% level to the 50% level, but when they do need extra cooling the fall will be slower and they will receive cooling for up to a further minute. When using the Figure 6 algorithm, it may be modified so that T_{on} is the time taken to reach set point rather than the complete period up until actual switch-off. The requirement that a majority of the cabinets demand cooling at the start of the next on period is not disturbed.

It should be appreciated that a method according to the invention can be applied to a multiple-capacity compressor system which runs at more than one different level of capacity during a compressor on period, but not at all during the off period. In that event, steps may occur in the plateau level when an additional capacity stage is switched in but nevertheless it is possible to detect the fall in load from the end of the plateau by any of the techniques referred to above.

It has previously been mentioned that the method of the invention may be applied to a compressor system which includes one, preferably relatively low capacity, compressor which runs all the time, and a main compressor which is operated in cycles, the purpose of the small compressor being to ensure that liquid refrigerant does not accumulate on the outlet sides of the evaporators which will be capable of damaging the main compressor when it is

- 23 -

switched on. In such a system, the continuous running of the small compressor would depress the level of the maximum pressure reached at the inlet of the main compressor as indicated by the broken line curve parts 18' and 38' shown in Figure 3. The pressure reduction may be even greater than is illustrated.

A control method in accordance with the invention can be applied to air conditioning, where the principles involved are the same as those in refrigeration. Furthermore, it can be applied to heat pumps. Heat pump systems are equivalent to refrigeration systems except that the purpose is to deliver heat in the condenser rather than remove it in the evaporator. Consequently, in applying the invention to heat pumps, it would be the compressor outlet pressure that is measured rather than its inlet pressure, this being an indication of the variable which it is intended to control, namely the temperature at which refrigerant is condensing in the condenser.

Figure 7 shows how this outlet pressure varies throughout a cycle in a manner opposite to that of the inlet pressure. The outlet pressure rises whilst the compressor is on and, provided that a majority of the heat pump output units are demanding heating at the time when the compressor is switched on, there is a plateau as shown at 22' at a relatively low pressure level, which represents

- 24 -

efficient operation of the heat pump system. Following the plateau, the compressor outlet pressure starts rising again as the heating demand from the output units falls, and the on period is then terminated in a similar manner to that used in the refrigeration system described in more detail. For example, the level of the plateau may be sensed, and a set point value may be set in response to that sensing at a level which is a desired percentage higher than the plateau level so as to ensure that the compressor is switched off relatively soon after the demand from the output units starts to fall. The compressor is then held off, for example in the ways already described in relation to a refrigeration system, for a sufficient period that when it comes on again at least a majority of the output units are again demanding heating.

Other attempts have been made to achieve the benefits of the present invention. For example, a rectifier/-inverter has been used to convert the mains frequency to a variable frequency so as to run the compressor at a variable speed to match the refrigeration demand, but this is complex and expensive.

Other arrangements for seeking to match capacity to demand include mechanical arrangements for shutting off a number of the cylinders of a compressor to reduce its capacity, over re-expansion compressors in which the com-

- 25 -

pression ratio can be changed to alter the capacity, and multiple compressors which can be switched on in varying numbers. In some applications, a control method of the present invention applied to a simple single compressor may achieved similar results to these more complex systems. However, the invention can also be applied to the control of such systems to improve their efficiency.

CLAIMS:

1. A method of controlling a compressor driven vapour compression heat movement system in which a common compressor system heats or cools a plurality of load units and is operated in cycles each of which include a compressor system higher capacity period and a compressor system lower capacity period, characterised in that the lower capacity period is made sufficiently long that when the compressor system is switched to the higher capacity a majority of the load units are demanding heating or cooling and that the higher capacity period is made sufficiently long that when the compressor system is switched to lower capacity one or more of the load units have had their heating or cooling demand satisfied.

2. A method as claimed in claim 1, wherein the lower capacity period is controlled so as to be sufficiently long.

3. A method as claimed in claim 2, wherein the length of the lower capacity period is controlled in dependence upon the length of the preceding higher capacity period.

4. A method as claimed in claim 2, wherein the lower capacity period is terminated in response to a sensed characteristic of the load units.

5. A method as claimed in claim 4, wherein the load units each include a thermostat system, and the sensed characteristic is the condition of the thermostat systems.

6. A method as claimed in claim 1, wherein the length of the lower capacity period is fixed at a sufficiently long value.

7. A method as claimed in any preceding claim, wherein said majority is at least 75%.

8. A method as claimed in any preceding claim, comprising sensing a variable which represents the load on the compressor system and utilising the value of the sensed variable in terminating the higher capacity period.

9. A method as claimed in claim 8, comprising terminating the higher capacity period when the sensed variable indicates that the load on the compressor system has fallen from a substantially constant load level.

10. A method as claimed in claim 8 or claim 9, wherein the system is a cooling system and the sensed variable is the compressor system inlet pressure.

11. A method as claimed in claim 8 or claim 9, wherein the system is a heating system and the sensed variable is the compressor system outlet pressure.

12. A method as claimed in claim 8 or claim 9, wherein the compressor system is electrically powered and the sensed variable is its current consumption.

13. A method as claimed in claim 8 or claim 9, wherein the compressor system is electrically powered and the sensed variable is its power consumption.

14. A method as claimed in claim 8 or claim 9, wherein the compressor system is electrically powered and the sensed variable is its power factor.

15. A method as claimed in claim 8 or claim 9, wherein the load units each include a thermostat system and the sensed variable is the number of thermostat systems demanding heating or cooling.

16. A method as claimed in any one of claims 8 to 15, comprising terminating the higher capacity period when the sensed variable reaches a set point value.

17. A method as claimed in any one of Claims 8 to 15 comprising establishing a set point value for the sensed variable and terminating the higher capacity period either when a predetermined period has elapsed after the sensed variable reaches the set point value, or when the sensed variable reaches a predetermined value different from the set point value, whichever is the sooner.

18. A method as claimed in Claim 16 or Claim 17, comprising sensing the occurrence of a substantially constant level of load on the compressor system during its higher capacity period and automatically adjusting the set point value to a value which would represent a load level lower than said substantially constant value.

19. A method as claimed in Claim 18, wherein the system is a cooling system and the set point value is set such that when the sensed variable reaches the set point value the compressor inlet pressure is between 60% and 90% of the absolute value which it has when the load is at said substantially constant level.

20. A method as claimed in any preceding claim, wherein the compressor system consists of a compressor and the higher capacity mode is when the compressor is on and the lower capacity mode is when the compressor is off.

21. A method as claimed in any one of Claims 1 to 19, wherein the compressor system includes a plurality of compressors, and in the higher capacity mode at least some of the compressors are running and in the lower capacity mode a lesser, fixed number which may be zero, are running.

22. A method of controlling a compressor driven vapour compression heat movement system in which a common compressor system heats or cools a plurality of load units and is operated in cycles each of which include a compressor system higher capacity period and a compressor system lower capacity period, characterised in that the lower capacity period is made sufficiently long that when the compressor system is switched to the higher capacity a majority of the load units are demanding heating or cooling and that the duration of the higher capacity period is controlled by monitoring a variable which represents the load on the compressor system and terminating the higher capacity period when the sensed variable indicates that the load on the compressor system has fallen from a substantially constant level.

23. A method as claimed in Claimm 22 including the further features specified in any of Claims 2 to 7 or 10 to 21.

SUBSTITUTE SHEET

24. A compressor driven vapour compression heat movement system in which a common compressor system heats or cools a plurality of load units, and comprising control means which controls the compressor system to operate in cycles each of which include a compressor system higher capacity period and a compressor system lower capacity period, the control means being adapted to make the lower capacity period sufficiently long that when the compressor system is switched to the higher capacity a majority of the load units are demanding heating or cooling and to make the higher capacity period sufficiently long that when the compressor system is switched to lower capacity one or more of the load units have had their heating or cooling demand satisfied.

25. A system as claimed in Claim 24, wherein the control means is adapted to control the lower capacity period so as to be sufficiently long.

26. A system as claimed in Claim 25, wherein the control means is adapted to sense the length of the higher capacity period and to control the length of the lower capacity period in dependence thereon.

27. A system as claimed in Claim 25, comprising means for sensing a characteristic of the load units, wherein the control means is adapted to terminate the lower capacity period in response to the sensing means.

-32-

28. A system as claimed in Claim 27, wherein the load units each include a thermostat system, and the sensing means senses the condition of the thermostat system.

29. A system as claimed in Claim 24, wherein the control means is adapted to fix the length of the lower capacity period at a sufficiently long value.

30. A system as claimed in any of Claims 24 to 29, wherein said majority is at least 75%.

31. A system as claimed in any of Claims 24 to 30, comprising means for sensing a variable which represents the load on the compressor system, the control means being adapted to utilise the value of the sensed variable in terminating the higher capacity period.

32. A system as claimed in Claim 31, wherein the control means is adapted to terminate the higher capacity period when the sensed variable indicates that the load on the compressor system has fallen from a substantially constant load level.

33. A system as claimed in Claim 31 or Claim 32, which is a cooling system and wherein the sensed variable is the compressor system inlet pressure.

-33-

34. A system as claimed in Claim 31 or Claim 32, which is a heating system and wherein the sensed variable is the compressor system outlet pressure.

35. A system as claimed in Claim 31 or Claim 32, wherein the compressor system is electrically powered and the variable sensed by the sensing means is its current consumption.

36. A system as claimed in Claim 31 or Claim 32, wherein the compressor system is electrically powered and the variable sensed by the sensing means is its power consumption.

37. A system as claimed in Claim 31 or Claim 32, wherein the compressor system is electrically powered and the variable sensed by the sensing means is its power factor.

38. A system as claimed in Claim 31 or Claim 32, wherein the load units each include a thermostat system and the variable sensed by the sensing means is the number of thermostat systems demanding heating or cooling.

39. A system as claimed in any one of Claims 31 to 38, wherein the control means is adapted to terminate the

SUBSTITUTE SHEET

higher capacity period when the sensed variable reaches a set point value.

40. A system as claimed in any one of Claims 31 to 38 wherein the control means is adapted to establish a set point value, and includes means for detecting when the sensed variable reaches the set point value, timing means for defining a predetermined period following said detection, means for terminating the on period, and means for activating said terminating means either at the expiry of the predetermined period or when the sensed variable reaches a predetermined value different from the set point value, whichever is the sooner.

41. A system as claimed in Claim 39 or 40, wherein the control means is adapted to sense the occurrence of a substantially constant level of load on the compressor system during its higher capacity period and to automatically adjust the set point value to a value which would represent a load level lower than said substantially constant value.

42. A system as claimed in Claim 41, which is a cooling system and wherein the control means is adapted to set the set point value such that when the sensed variable reaches the set point value the compressor inlet pressure is between 60% and 90% of the absolute value

-35-

which it has when the load is at said substantially constant level.

43. A system as claimed in any one of Claims 24 to 42, wherein the compressor system consists of a compressor and the higher capacity mode is when the compressor is on and the lower capacity mode is when the compressor is off.

44. A system as claimed in any one of Claims 24 to 42, wherein the compressor system includes a plurality of compressors, and in the higher capacity mode at least some of the compressors are running and in the lower capacity mode a lesser, fixed number which may be zero, are running.

45. A compressor driven vapour compression heat movement system in which a common compressor system heats or cools a plurality of load units, comprising control means which controls the system to operate in cycles each of which include a compressor system higher capacity period and a compressor system lower capacity period, the control means being adapted to make the lower capacity period sufficiently long that when the compressor system is switched to the higher capacity a majority of the load units are demanding heating or cooling and to control the duration of the higher capacity period by monitoring a

SUBSTITUTE SHEET

variable which represents the load on the compressor system and terminating the higher capacity period when the sensed variable indicates that the load on the compressor system has fallen from a substantially constant level.

46. A system as claimed in Claim 45, including the further features specified in any of Claims 26 to 31 or 34 to 44.

47. A control means for controlling a compressor driven vapour compression heat movement system in which a common compressor system heats or cools a plurality of load units, the control means comprising an input for receiving a signal representing the load on the compressor system, means for detecting when the signal represents a substantially constant level of load, and means for utilising said detection in generating a control signal usable to switch the compressor system to a lower capacity mode.

n

48. A control means as claimed in Claim 47 wherein the means for utilising said detection in generating a control signal includes means for providing a set point signal representing a predetermined fraction of the substantially constant load level, means for detecting when the signal representing load reaches the value of

-37-

the set point signal, and means for generating said control signal in dependence upon said detection.

49. A control means as claimed in Claim 48 wherein the means for generating said control signal is immediately responsive to said detection.

50. A control means as claimed in Claim 48 wherein the means for generating said control signal includes timing means for defining a predetermined period following said detection, means for defining a value different from the set point value, and means for producing said control signal when the predetermined period has expired or the signal representing load has reached said different value, whichever is the sooner.

1/4

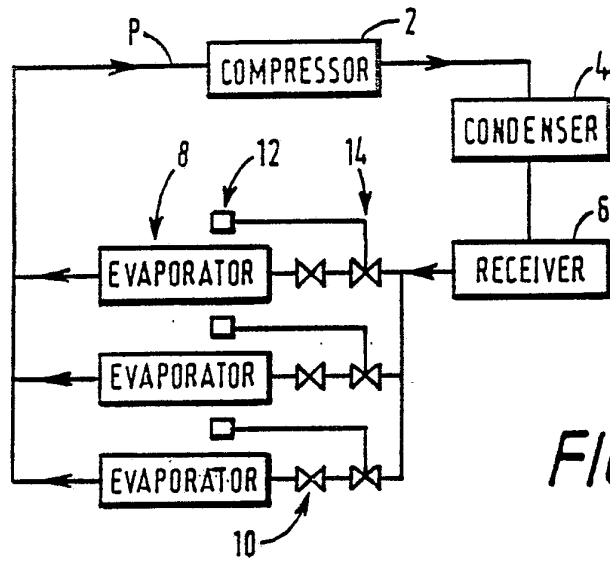

FIG. 1 ✓

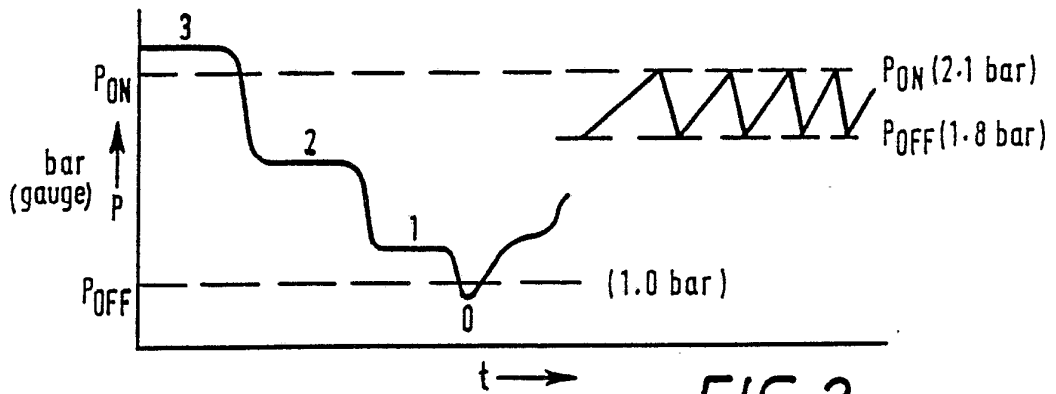

FIG. 2

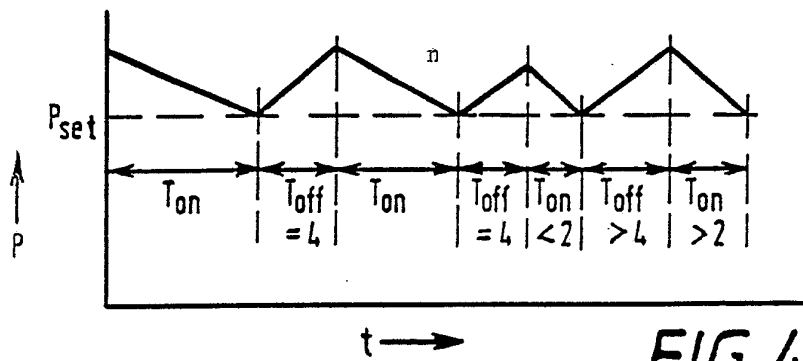

FIG. 4

2/4

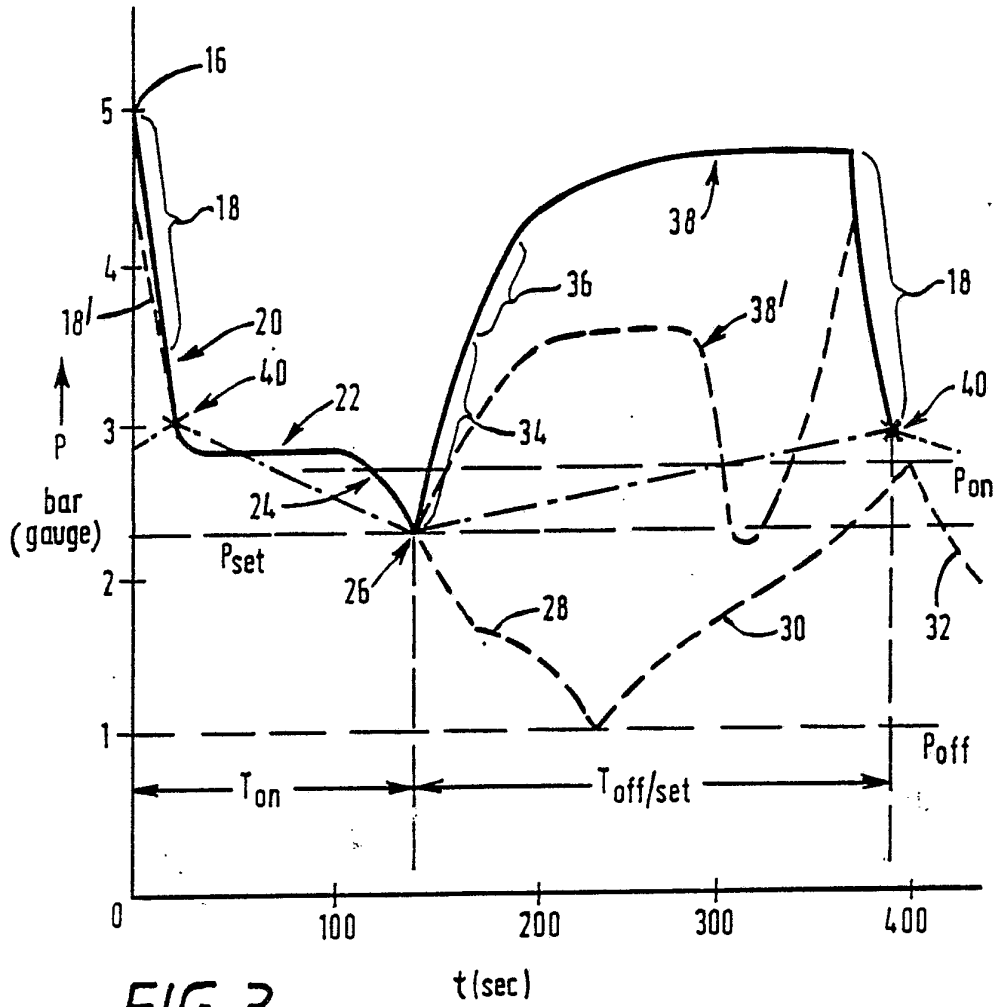

FIG. 3

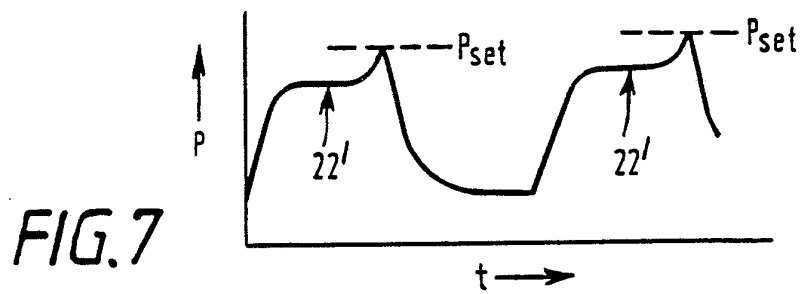
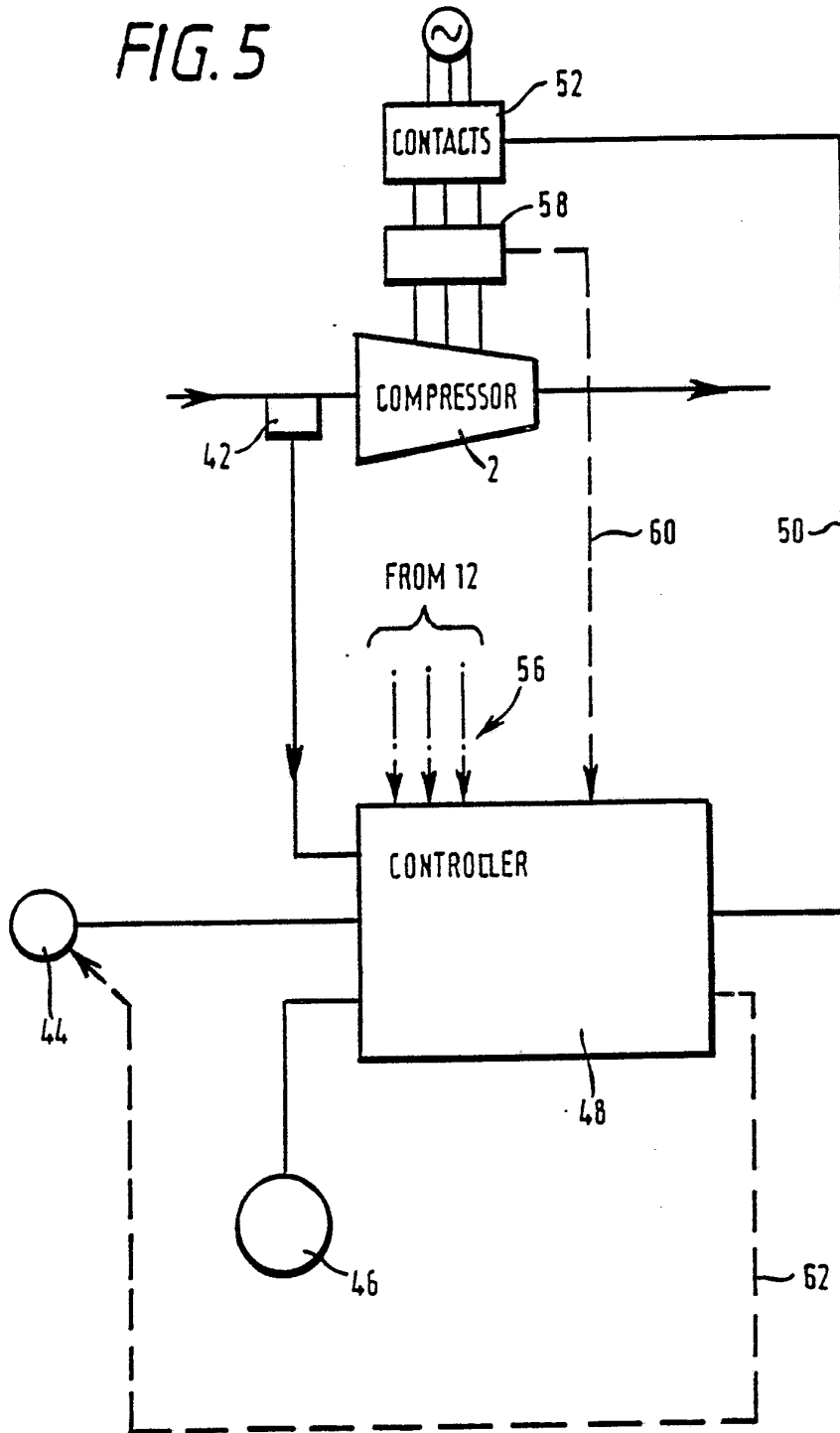

FIG. 7

3/4

FIG. 5



4/4

FIG. 6

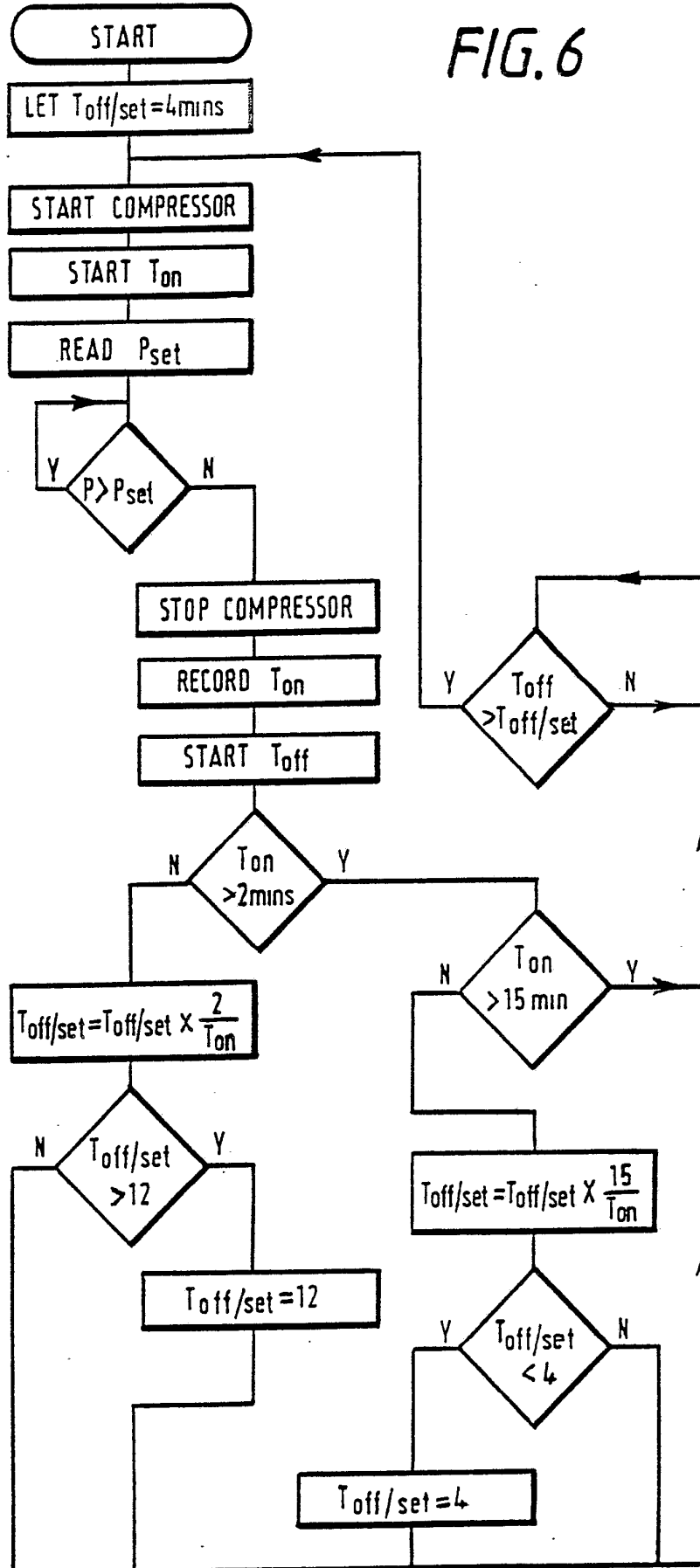

INTERNATIONAL SEARCH REPORT

International Application No PCT/GB 88/00131

I. CLASSIFICATION OF SUBJECT MATTER (if several classification symbols apply, indicate all) ⁴		
According to International Patent Classification (IPC) or to both National Classification and IPC		
IPC ⁴ : F 25 B 49/00; F 25 B 5/00		
II. FIELDS SEARCHED		
Minimum Documentation Searched ⁷		
Classification System	Classification Symbols	
IPC ⁴	F 25 B	
Documentation Searched other than Minimum Documentation to the Extent that such Documents are Included in the Fields Searched ⁸		
III. DOCUMENTS CONSIDERED TO BE RELEVANT⁹		
Category ⁹	Citation of Document, ¹¹ with indication, where appropriate, of the relevant passages ¹²	Relevant to Claim No. ¹³
A	US, A, 4292813 (PADDOCK) 6 October 1981 see column 3, line 43 - column 9, line 48; figures 1-7 --	1-5, 8, 15, 20, 22-28, 31, 38, 45, 46
A	US, A, 3817052 (CONNELLY) 18 June 1974 see column 2, line 42 - column 8, line 26; figures 1-3 --	1, 2, 5, 6, 10, 16, 20, 22-25, 28, 29, 33, 39, 43, 45, 46
A	US, A, 3700914 (GRANIERI) 24 October 1972 see column 2, line 20 - column 8, line 2; figures 1-3 --	1, 2, 4-6, 8, 15, 16, 20, 22-25, 27-29, 31, 38, 39, 43, 45, 46
A	US, A, 4393662 (DIRTH) 19 July 1983 see column 3, line 36 - column 25, line 2; figures 1-10 --	13, 15, 23, 24, 26, 38, 46
A	US, A, 4384462 (OVERMAN) 24 May 1983 see column 4, line 10 - column 12, line 52; figures 1-8 --	1, 4, 8-10, 16, 21-24, 27, 31- 33, 39, 44-46 ./.
<p>⁹ Special categories of cited documents: ¹⁰</p> <p>"A" document defining the general state of the art which is not considered to be of particular relevance</p> <p>"E" earlier document but published on or after the international filing date</p> <p>"L" document which may throw doubts on priority claim(s) or which is cited to establish the publication date of another citation or other special reason (as specified)</p> <p>"O" document referring to an oral disclosure, use, exhibition or other means</p> <p>"P" document published prior to the international filing date but later than the priority date claimed</p> <p>"T" later document published after the international filing date or priority date and not in conflict with the application but cited to understand the principle or theory underlying the invention</p> <p>"X" document of particular relevance; the claimed invention cannot be considered novel or cannot be considered to involve an inventive step</p> <p>"Y" document of particular relevance; the claimed invention cannot be considered to involve an inventive step when the document is combined with one or more other such documents, such combination being obvious to a person skilled in the art.</p> <p>"&" document member of the same patent family</p>		
IV. CERTIFICATION		
Date of the Actual Completion of the International Search	Date of Mailing of this International Search Report	
25th May 1988	29 JUN 1988	
International Searching Authority	Signature of Authorized Officer	
EUROPEAN PATENT OFFICE	 P.E.G. VAN DER PUTTEN	

III. DOCUMENTS CONSIDERED TO BE RELEVANT (CONTINUED FROM THE SECOND SHEET)		
Category *	Citation of Document, with indication, where appropriate, of the relevant passages	Relevant to Claim No
A	US, A, 4614089 (DORSEY) 30 September 1986 see column 5, line 32 - column 16, line 31; figures 1-7 --	1,4,8,10,16, 21-24,27,31, 33,39,44-46
A	US, A, 3636369 (HARTER) 18 January 1972 see column 1, line 16 - column 4, line 56; figures 1-4 --	1,6,10,20,24 29,33,43
A	US, A, 4537038 (ALSENZ) 27 August 1985 see column 4, line 28 - column 13, line 6; figures 1-6 --	1,8,10,16,20 22-24,31,33, 39,44-46
A	WO, A, 8100446 (ALSENZ) 19 February 1981 see page 5, line 12 - page 15, line 19; figures 1-4 --	1,8,10,16,21 -24,31,33,39 44-46
A	WO, A, 8400603 (BENDIKSON) 16 February 1984 see page 8, line 17 - page 14, line 17; figures 1-3 --	1,10,20,22- 24,33,43,45, 46
A	US, A, 4510767 (KOMATSU) 16 April 1985 see column 2, line 42 - column 14, line 65; figures 1-14 --	1,8,15,20,22 -24,31,38,43 45,46
A	US, A, 4494382 (RAYMOND) 22 January 1985 see column 2, line 13 - column 3, line 19; column 4, line 57 - column 14, line 56; figures 1-6 --	1,4,8,10-12, 22,24,27,31, 33-35,45
A	US, A, 4152902 (LUSH) 8 May 1979 --	
A	DE, A, 2016048 (STAL REFRIGERATION) 18 February 1971 --	
A	CH, A, 204345 (CARBA) 1 June 1939 -----	

**ANNEX TO THE INTERNATIONAL SEARCH REPORT
ON INTERNATIONAL PATENT APPLICATION NO.**

GB 8800131
SA 20833

This annex lists the patent family members relating to the patent documents cited in the above-mentioned international search report. The members are as contained in the European Patent Office EDP file on 09/06/88. The European Patent Office is in no way liable for these particulars which are merely given for the purpose of information.

Patent document cited in search report	Publication date	Patent family member(s)	Publication date
US-A- 4292813	06-10-81	JP-A- 55124816	26-09-80
		CA-A- 1153447	06-09-83
US-A- 3817052	18-06-74	CA-A- 996237	31-08-76
US-A- 3700914	24-10-72	None	
US-A- 4393662	19-07-83	None	
US-A- 4384462	24-05-83	None	
US-A- 4614089	30-09-86	None	
US-A- 3636369	18-01-72	None	
US-A- 4537038	27-08-85	None	
WO-A- 8100446	19-02-81	EP-A, B 0034591	02-09-81
		AU-A- 6129480	03-03-81
		CA-A- 1158745	13-12-83
		AT-B- E11338	15-02-85
		AU-B- 543220	04-04-85
		US-A- 4612776	23-09-86
		US-A- 4628700	16-12-86
US-A- 4679404	14-07-87		
WO-A- 8400603	16-02-84	EP-A- 0114812	08-08-84
		US-A- 4602484	29-07-86
US-A- 4510767	16-04-85	JP-A- 58006381	13-01-83
		JP-A- 58016166	29-01-83
		JP-A- 58026977	17-02-83
		JP-A- 58026978	17-02-83
		JP-A- 58187762	02-11-83
US-A- 4494382	22-01-85	JP-A- 60082757	10-05-85
		FR-A- 2553184	12-04-85
US-A- 4152902	08-05-79	None	

ANNEX TO THE INTERNATIONAL SEARCH REPORT
ON INTERNATIONAL PATENT APPLICATION NO.

GB 8800131

SA 20833

This annex lists the patent family members relating to the patent documents cited in the above-mentioned international search report. The members are as contained in the European Patent Office EDP file on 09/06/88. The European Patent Office is in no way liable for these particulars which are merely given for the purpose of information.

Patent document cited in search report	Publication date	Patent family member(s)	Publication date
DE-A- 2016048	18-02-71	GB-A- 1248888	06-10-71
CH-A- 204345		None	