

March 16, 1937.

F. RONOWSKY

2,073,807

ARTIFICIAL LIMB

Filed Sept. 2, 1936

4 Sheets—Sheet 1

Fig. 1.

Fig. 2.

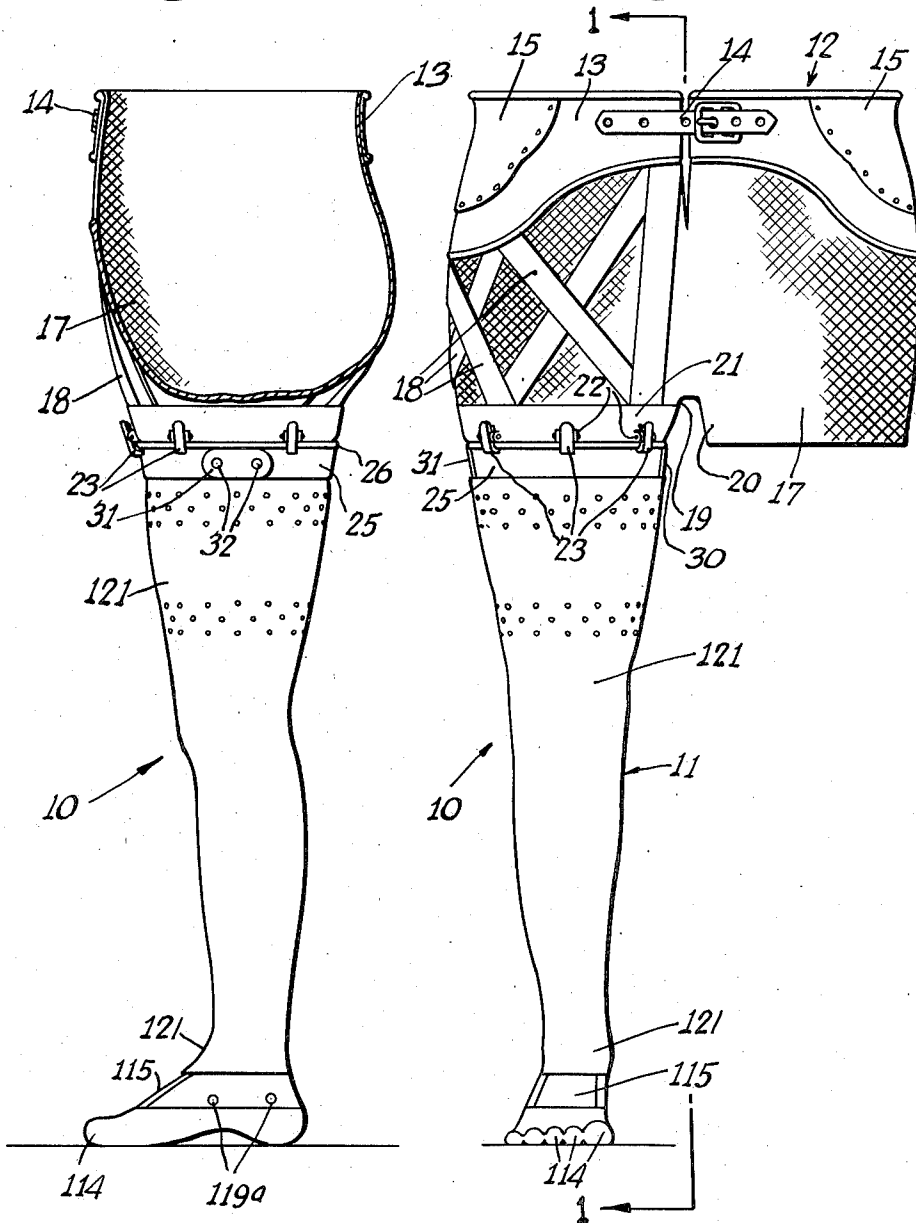

INVENTOR
Frank Ronowsky

BY
Carl Miller
ATTORNEY

March 16, 1937.

F. RONOWSKY

2,073,807

ARTIFICIAL LIMB

Filed Sept. 2, 1936

4 Sheets-Sheet 2

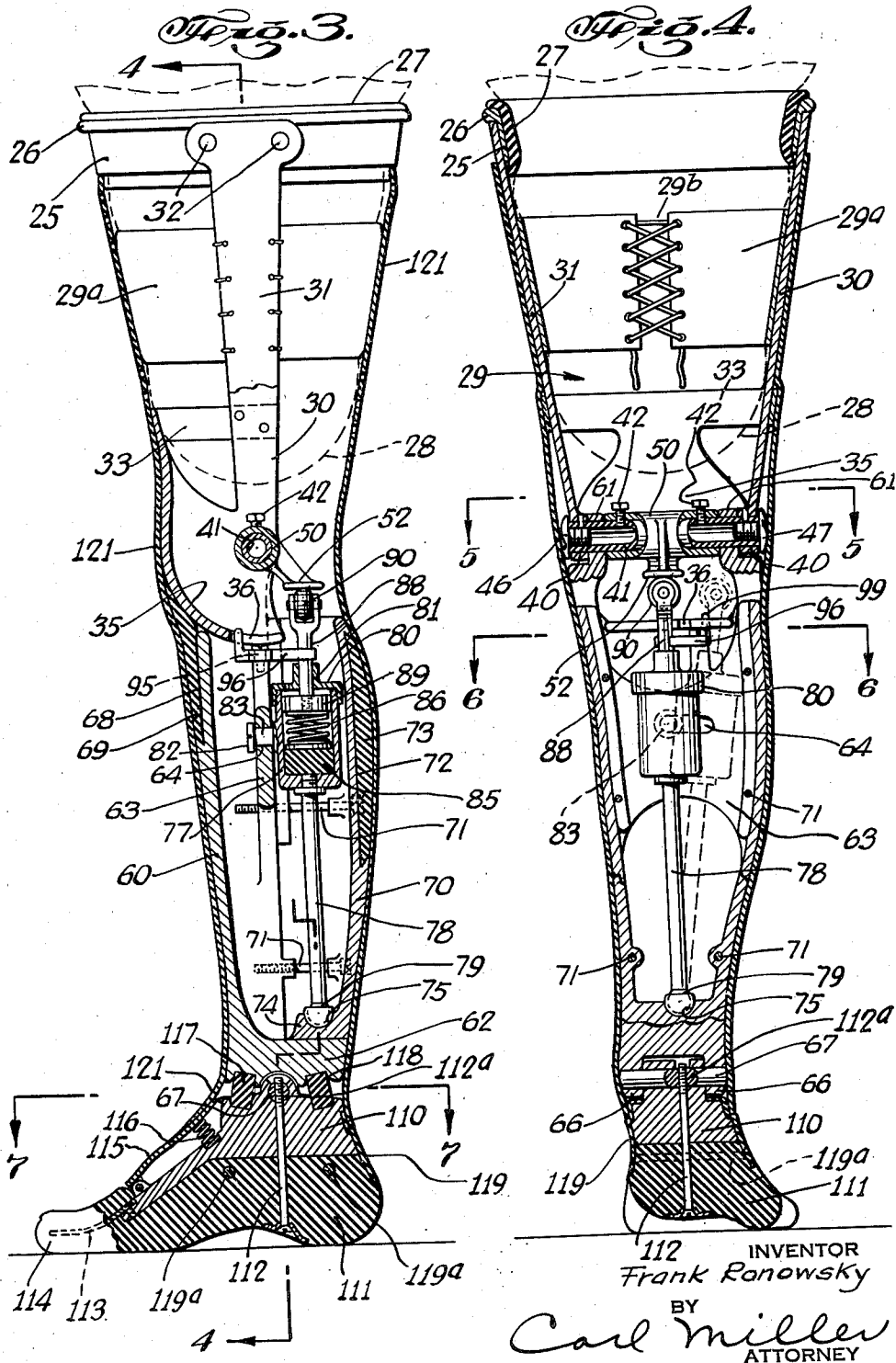

March 16, 1937.

F. RONOWSKY

2,073,807

ARTIFICIAL LIMB

Filed Sept. 2, 1936

4 Sheets-Sheet 3

Fig. 5.

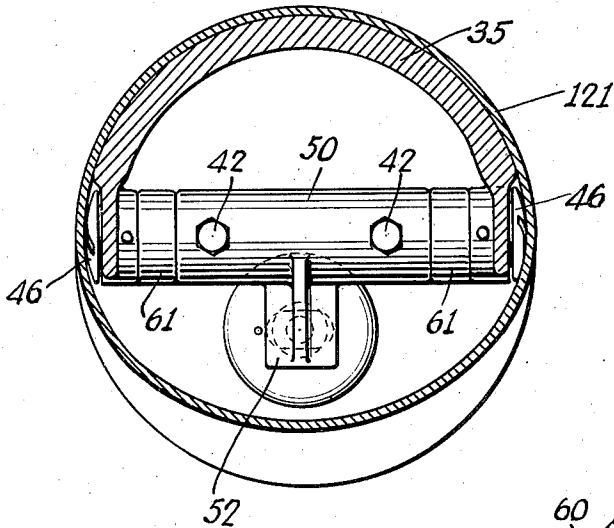

Fig. 6.

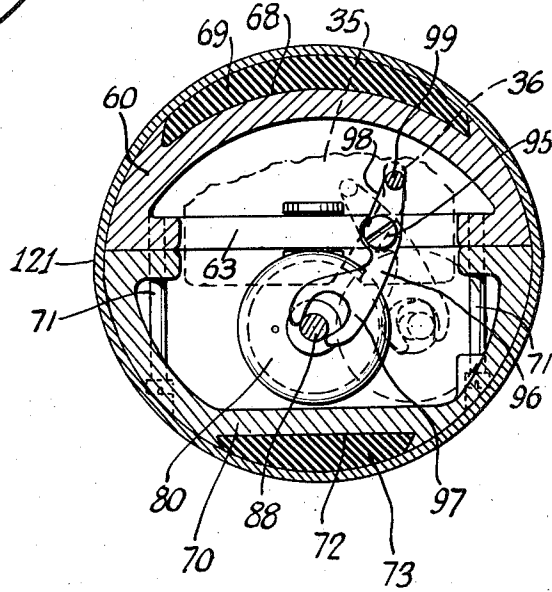
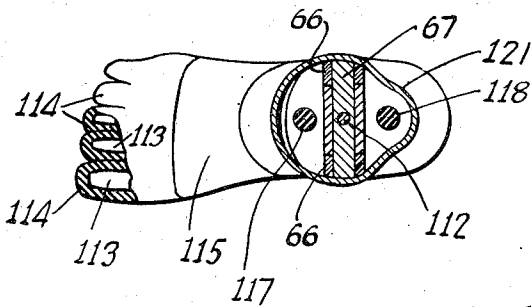

Fig. 7.



INVENTOR
Frank Ronowsky

BY
Carl Miller
ATTORNEY

March 16, 1937.

F. RONOWSKY
ARTIFICIAL LIMB
Filed Sept. 2, 1936

2,073,807

4 Sheets-Sheet 4

Fig. 8.

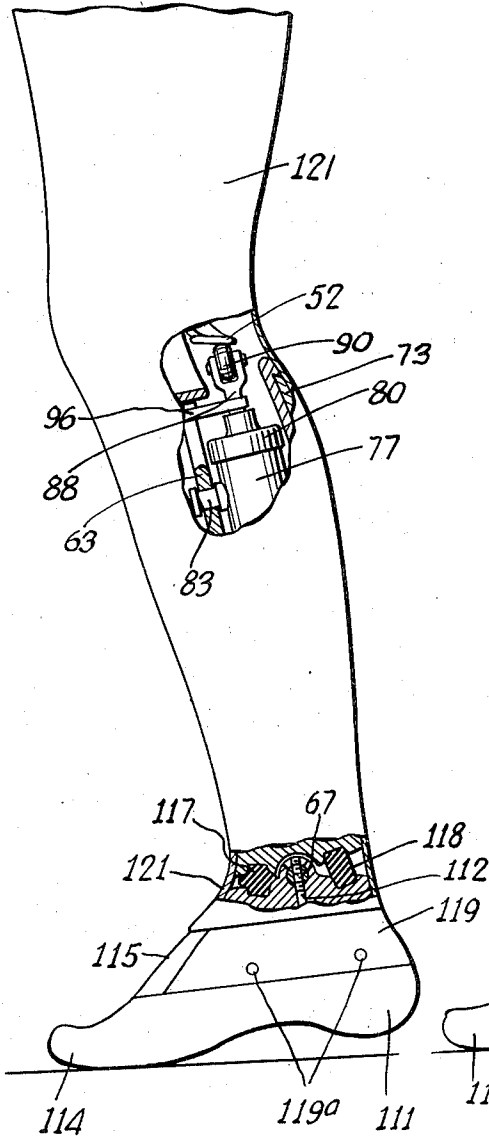
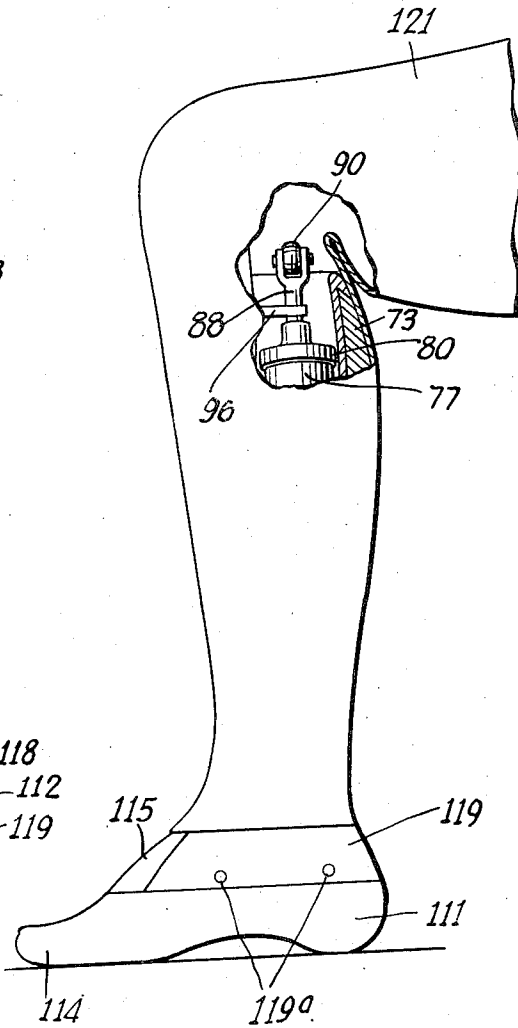

Fig. 9.



INVENTOR
Frank Ronowsky

BY
Carl Miller
ATTORNEY

UNITED STATES PATENT OFFICE

2,073,807

ARTIFICIAL LIMB

Frank Ronowsky, Bath, N. Y.

Application September 2, 1936, Serial No. 99,078

3 Claims. (Cl. 3—2)

This invention relates to artificial limbs, and is particularly directed to an artificial leg, and the like devices.

An object of this invention is to provide an artificial limb of the character described, provided with improved means for yieldingly resisting bending of the knee when walking or going up and down stairs, or onto or off a sidewalk.

A further object of this invention is to provide an artificial leg of the character described, having means to permit bending of the knee to a considerable degree, as for example, when sitting down, the construction being such as to automatically render the resisting means inoperative upon bending the knee more than a predetermined angle.

A still further object of this invention is to provide an artificial leg of the character described, provided with improved means for bending the foot portion and flexing of the toe portions thereof.

Another object of this invention is to provide a compact and durable artificial leg of the character described, which shall be comfortable in use, easy to apply to or remove from the body, comprise comparatively few and simple parts, be relatively inexpensive to manufacture, and withal, practical and efficient to a high degree.

Other objects of this invention will in part be obvious and in part hereinafter pointed out.

The invention accordingly consists in the features of construction, combinations of elements, and arrangement of parts which will be exemplified in the construction hereinafter described, and of which the scope of application will be indicated in the following claims.

In the accompanying drawings, in which is shown one of the various possible illustrative embodiments of this invention,

Fig. 1 is an elevational view of an artificial leg embodying the invention, and being a cross section on line 1—1 of Fig. 2;

Fig. 2 is a front elevational view of my improved artificial leg;

Fig. 3 is an elevational, cross-sectional view of the artificial leg with the means for attaching the same to the body removed;

Fig. 4 is a cross-sectional view taken on line 4—4 of Fig. 3;

Fig. 5 is a cross-sectional view taken on line 5—5 of Fig. 4;

Fig. 6 is a cross-sectional view taken on line 6—6 of Fig. 4;

Fig. 7 is a cross-sectional view taken on line 7—7 of Fig. 3;

Fig. 8 is a side elevational view of the artificial leg shown in the position thereof when slightly bent while walking, with parts broken away to show the interior construction; and

Fig. 9 is a side elevational view of my improved artificial leg when the wearer is in sitting position, with parts broken away and in cross section.

Referring now in detail to the drawings, 10 designates an artificial leg embodying the invention. The same comprises a leg portion 11 and a device 12 for fixing the same onto the body of the wearer. The device 12 is in the form of a garment adapted to fit about the hips of the wearer from the waist to just below the crotch. The same comprises a leather portion 13, encircling the waist and extending downwardly at the sides partially over the hips and being split at the front, the split portions being fastened together by a strap and buckle 14. Sheet metal plates 15 may be riveted to the sides of the portion 10, shaped to conform to the contour of the hips of the body. Attached to the leather portion 13 and extending downwardly therefrom, is a member 17 made of fabric in the form of a pair of trunks extending downwardly to just below the crotch.

The side of the trunks 17, to which the artificial leg 11 is to be attached, may be reinforced by a plurality of crossing elastic rubber cords 18. The trunks 17 have two short leg portions 19 and 20. Attached to the bottom edge of one of the leg portions, in any suitable manner, is an annular frusto-conical shaped metallic band 21 formed with a plurality of spaced hinges 22, carrying spring pressed clips 23, for the purpose hereinafter appearing.

The leg 11 comprises an annular frusto-conical metallic band 25 formed with an annular bead 26 at its top edge adapted to be engaged by the spring clips 23. Fixed to the inside of the band is an annular ring 27 of soft rubber. The stump 28 of the wearer's leg is adapted to fit within the rubber ring 27 and project through the band 26. Fixed to the sides of the metal band 25, is a member or thigh piece 29 made of metal and having a pair of aligned downwardly and inwardly converging portions 30 and 31, the upper ends whereof are riveted to said band as at 32. The portions 30 and 31 are interconnected by a forwardly curved portion 33 from which there extends downwardly a curved or part spherical knee cap portion 35. The portion 35, as shown in Fig. 3, is curved inwardly to substantially the axis of the leg and the rear edge thereof is provided, as shown in Fig. 6 in dotted lines, with a slot 36 disposed in an inwardly inclined plane.

Fixed to said portions 30, 31 of member 29, is a wide, frusto-conical leather strap 29a receiving the leg stump and having ends laced together as at 29b. At the lower ends thereof the side portions 30, 31 of the member 29 are formed with a pair of aligned openings 40 supporting a horizontal sleeve 41 fixed to said side portions. Screwed within the ends of the sleeve 41 are a pair of stud screws 46 and 47. Received on said sleeve and fixed thereto by screws 42 is a second sleeve 50.

Mounted on said sleeve 41, is a member 60, having a pair of spaced apertured fingers 61 rotatably receiving said sleeve and disposed on the inner sides of the bearings 40. The member 60 is hollow and shaped substantially to conform to the contour of the front of the leg from the knee to substantially the ankle. At the bottom thereof, the member 60 has a portion 62 conforming to the cross section of the ankle portion of the leg. Said member 60 may be made of relatively light metal, such as aluminum, so as not to make the leg too heavy. The same is provided with an integral vertical web 63 below the knee and disposed in a plane extending from side to side. Said web is provided with an arcuate slot 64, preferably extending from the axis of the leg to one side thereof, as shown in Fig. 4 of the drawings.

The portion 62 of the member 60 is provided with a pair of downwardly extending parallel fingers 66 formed with aligned openings rotatably receiving a horizontal cross pin 67, disposed in the plane of web 63, for the purpose hereinafter appearing. At the front, upper part thereof, the member 60 is formed with a depression or socket 68, receiving a block 69 of rubber, conforming substantially to the shape of the knee and having a spherical shaped inner surface contacting the knee cap portion 35 of the member 29. Mounted on the portion 62 of the member 60, is a member 70 conforming generally to the shape of the rear of the leg from below the knee to substantially the ankle. Said member 70 may likewise be made of aluminum or other relatively light and strong material, and is fixed to the member 60 by a plurality of screws 71. The upper rear portion of the member 70 is formed with a socket 72 receiving a block 73 of soft rubber, the outer surface of which conforms to the contour of the muscle at the rear of the leg. The member 70 is likewise hollow and the portion 74 thereof which rests on the portion 62 of the member 60 has a ball socket 75 in the upper surface thereof.

Mounted within the leg and between the members 60 and 70, is a cylinder 77, to the bottom of which there is attached a rod 78 having a ball 79 at the lower end thereof received within the socket 75. Screwed to the top of the cylinder, is a cylinder cap 80 having an axial opening 81. On the cylinder 77 is a pin 82 carrying a roller 83, disposed within the slot 64. Within the bottom of the cylinder is a block 85 of soft rubber. On said block is a compression spring 86. Extending through the axial opening 81 in the cylinder cap 80, is a piston stem 88 carrying a piston 89 disposed within said cylinder and contacting the spring 86. At the upper end of the stem 88 is a roller 90 contacting and engaged within the stop member 52 when the leg is substantially bent.

Pivoted on the web portion 63 of the member 60 on a vertical axis, as at 95, is a lever 96 having one bifurcated arm 97 engaging the stem 88 of the piston 89, and another arm 98 provided with

an upwardly extending finger 99 projecting into the slot 36 of knee cap member 35.

When the leg is straight, the piston, cylinder and connecting rod are substantially in vertical position. Slight bending movement of the knee, as when walking or mounting steps, will cause the stop member 52 to press downwardly on the roller for compressing the spring 86 and rubber block 85, which serve to yieldingly resist and absorb shock due to bending, while providing the yield necessary for the slight bending of the knee. However, should the knee be bent substantially to 90 degrees, as for example, when the wearer sits down, the slot 36 of knee cap member 35 will cause pivotal movement of the lever 96 for swinging the piston from the full to the dotted line position of Fig. 4. When the leg has been bent a predetermined degree, the lever will move the roller 90 off the stop 52, the roller 83 moving within the slot 64. As soon as the stop 52 clears roller 90 on the piston stem, the knee may be bent to the full 90 degrees without resistance from the piston and cylinder.

When the leg is straightened again, as for example, when the person rises from sitting position, the projection 99 will again enter the slot 36 and cause the lever to swing from the dotted to the full line positions shown in Fig. 6 of the drawings, for moving the piston and cylinder to vertical position, whereby the roller 90 again moves under stop 52.

Pivoted on the cross pin 67 is a member 110 made of aluminum or other light spring material and having a portion disposed between the spaced fingers 66 at the lower end of the member 60. Fixed to the bottom of the member 110 is a block 111 made of rubber and having a shape conforming to the foot. The block 111 may be attached to the member 110 by means of a vertical screw 112 extending through said block and through the member 110 and engaging within a transverse threaded opening 112A in the cross pin 67. Fixed to the member 110 are a plurality of strips 113 of spring metal, each projecting into one of the toe portions 114 of the block 111. Pivoted to the member 110, is a metal plate 115, conforming to the shape of the instep of the foot. A light coil compression spring 116 may be interposed between the member 115 and the member 110. Interposed between the lower end of the portion 62 and the top of the member 110 are a pair of rubber blocks 117 and 118 disposed on opposite sides of the cross pin 67 respectively. Surrounding the sides and back of the ankle is a sheet metal plate 119. The member 111 may be fixed to said member 119 by transverse rivets 119a.

Covering the members 60, 70, the blocks 69, 73, the member 29 and the strap 29a, is a sleeve or covering 121 of thin flexible material, for example, rubber simulating skin. The bottom end of the member 121 overlaps the upper edge of the members 115 and 119. Said sleeve or covering 121 may have perforations 123 in the upper portion thereof to permit circulation of air within the leg 11.

It will thus be seen that there is provided a device in which the several objects of this invention are achieved, and which is well adapted to meet the conditions of practical use.

As various possible embodiments might be made of the above invention, and as various changes might be made in the embodiment above set forth, it is to be understood that all matter herein set forth or shown in the accompanying

drawings is to be interpreted as illustrative and not in a limiting sense.

Having thus described my invention, I claim as new and desire to secure by Letters Patent:

5 1. An artificial leg comprising a thigh portion, a leg portion hinged thereto, a cylinder on one of said portions, a piston within said cylinder and having a stem projecting from said cylinder, yielding resisting means between said piston and
10 cylinder, said other portion having means to engage the piston stem and move said piston within said cylinder upon bending of the leg, and means for disengaging the piston stem from said last mentioned means upon bending the leg be-
15 yond a predetermined angle.

2. An artificial leg comprising a thigh portion, a leg portion pivoted thereto, a member fixed with respect to said thigh portion and having a projecting arm constituting a stop member, a rod
20 having a ball and socket connection at one end thereof, to said leg portion, a cylinder fixed to

said rod, yielding compressible means within said cylinder, a piston within said cylinder engaging said compressible means, and a stem on said piston having a roller engaging said stop.

3. An artificial leg comprising a thigh portion, 5 a leg portion pivoted thereto, a member fixed with respect to said thigh portion and having a projecting arm constituting a stop member, a rod having a ball and socket connection at one end thereof, to said leg portion, a cylinder fixed
10 to said rod, yielding compressible means within said cylinder, a piston within said cylinder engaging said compressible means, a stem on said piston having a roller engaging said stop, said thigh member having an integral knee cap portion formed with an inclined slot, and a lever
15 pivoted to said leg portion and having a projection at one end engaging within said slot, the other of end of said lever engaging said piston stem.

FRANK RONOWSKY. 20