



(51) International Patent Classification:

H01Q 1/24 (2006.01) *H01Q 5/20* (2015.01)
H01P 1/18 (2006.01) *H01Q 5/28* (2015.01)
H01Q 3/36 (2006.01) *H01Q 5/50* (2015.01)
H01Q 21/30 (2006.01)

(21) International Application Number:

PCT/US2014/063882

(22) International Filing Date:

4 November 2014 (04.11.2014)

(25) Filing Language:

English

(26) Publication Language:

English

(30) Priority Data:

61/925,903 10 January 2014 (10.01.2014) US
14/274,321 9 May 2014 (09.05.2014) US

(71) Applicant: **ANDREW LLC** [US/US]; 1100 CommScope Place SE, Hickory, NC 28602 (US).

(72) Inventors: **KURK, Morgan, C.**; 3715 Woodglen Lane, Sachse, TX 75048 (US). **ZIMMERMAN, Martin, L.**; 1909 North Larrabee Street, Unit A, Chicago, IL 60614 (US).

(74) Agents: **SHEKLETON, Gerald T.** et al.; Husch Blackwell LLP, 120 S. Riverside Plaza, Suite 2200, Chicago, IL 60606 (US).

(81) Designated States (unless otherwise indicated, for every kind of national protection available): AE, AG, AL, AM, AO, AT, AU, AZ, BA, BB, BG, BH, BN, BR, BW, BY, BZ, CA, CH, CL, CN, CO, CR, CU, CZ, DE, DK, DM, DO, DZ, EC, EE, EG, ES, FI, GB, GD, GE, GH, GM, GT, HN, HR, HU, ID, IL, IN, IR, IS, JP, KE, KG, KN, KP, KR, KZ, LA, LC, LK, LR, LS, LU, LY, MA, MD, ME, MG, MK, MN, MW, MX, MY, MZ, NA, NG, NI, NO, NZ, OM, PA, PE, PG, PH, PL, PT, QA, RO, RS, RU, RW, SA, SC, SD, SE, SG, SK, SL, SM, ST, SV, SY, TH, TJ, TM, TN, TR, TT, TZ, UA, UG, US, UZ, VC, VN, ZA, ZM, ZW.

(84) Designated States (unless otherwise indicated, for every kind of regional protection available): ARIPO (BW, GH, GM, KE, LR, LS, MW, MZ, NA, RW, SD, SL, ST, SZ, TZ, UG, ZM, ZW), Eurasian (AM, AZ, BY, KG, KZ, RU, TJ, TM), European (AL, AT, BE, BG, CH, CY, CZ, DE, DK, EE, ES, FI, FR, GB, GR, HR, HU, IE, IS, IT, LT, LU, LV, MC, MK, MT, NL, NO, PL, PT, RO, RS, SE, SI, SK, SM, TR), OAPI (BF, BJ, CF, CG, CI, CM, GA, GN, GQ, GW, KM, ML, MR, NE, SN, TD, TG).

Published:

— with international search report (Art. 21(3))

(54) Title: ENHANCED PHASE SHIFTER CIRCUIT TO REDUCE RF CABLES

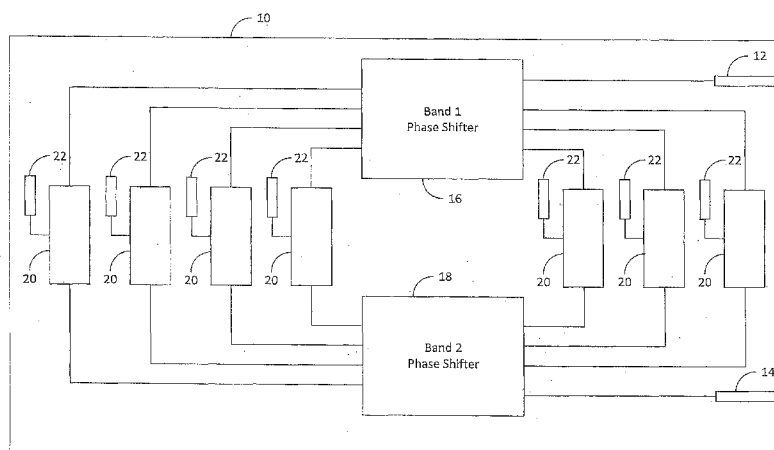

Fig. 1

(57) Abstract: A multi-band antenna system includes an array of wide-band radiating elements and a multi-band electrical tilt circuit. The multi-band electrical tilt circuit includes a plurality of combiners, a first RF band variable phase shifter and a second RF band variable phase shifter implemented in a common medium. The common medium may comprise a PCB, a stripline circuit, or the like. Each combiner includes a combined port, a first RF band port, and a second RF band port. The combined ports are coupled to the radiating elements. The first RF band phase shifter has a first plurality of variably phase shifted ports connected to the first RF band ports of the combiners via transmission line, and the second RF band phase shifter has a second plurality of variably phase-shifted ports connected to the second RF band ports of the combiners via transmission line. The phase shifters are independently configurable.



ENHANCED PHASE SHIFTER CIRCUIT TO REDUCE RF CABLES

RELATED APPLICATIONS

This application is related to provisional application Serial No. 61/925,903, this disclosure of which is incorporated by reference.

Background

The present invention relates generally to wireless communications antennas. In particular, the invention relates to an improved feed network for using an array of radiating elements for more than one band of communications frequencies.

Dual band antennas for wireless voice and data communications are known. For example, common frequency bands for GSM services include GSM900 and GSM1800. GSM900 operates at 880-960 MHz. GSM1800 operates in the frequency range of 1710-1880 MHz. Antennas for communications in these bands of frequencies typically include an array of radiating elements connected by a feed network. For efficient transmission and reception of Radio Frequency (RF) signals, the dimensions of radiating elements are typically matched to the wavelength of the intended band of operation. Because the wavelength of the 900MHz band is longer than the wavelength of the 1800MHz band, the radiating elements for one band are typically not used for the other band. In this regard, dual band antennas have been developed which include different radiating elements for the two bands. See, for example, U.S. Patent No. 6,295,028, U.S. Patent No. 6,333,720, U.S. Patent No. 7,238,101 and U.S. Patent No. 7,405,710 the disclosures of which are incorporated by reference.

In some dual band systems, wide band radiating elements are being developed. In such systems, there are at least two arrays of radiating elements, including one or more arrays of low band elements for low bands of operating frequencies (e.g., GSM900 and/or Digital Dividend at 790-862 MHz), and one or more arrays of high band radiating elements for high bands of operating frequencies (e.g., GSM1800 and/or UTMS at 1920 MHz – 2170 MHz).

Known dual band antennas, while useful, may not be sufficient to accommodate future traffic demands. Wireless data traffic is growing dramatically in various global markets. There are growing number of data service subscribers and increased traffic per subscriber. This is due, at least in part, to the growing popularity of "smart phones," such as the iPhone, Android-based devices, and wireless modems. The increasing demand of wireless data is exceeding the capacity of the traditional two-band wireless communications networks. Accordingly, there are additional bands of frequencies which are being used for wireless communications. For example, LTE2.6 operates at 2.5-2.7GHz and WiMax operates at 3.4-3.8GHz.

One solution is to add additional antennas to a tower to operate at the LTE and higher frequencies. However, simply adding antennas poses issues with tower loading and site permitting/zoning regulations. Another solution is to provide a multiband antenna that includes at least one array of radiating elements for each frequency band. See, for example, U.S. Pat. Pub. No. 2012/0280878, the disclosure of which is incorporated by reference. However, multiband antennas may result an increase in antenna width to accommodate an increasing number of arrays of radiating elements. A wider antenna may not fit in an existing location or, if it may physically be mounted to an existing tower, the tower may not have been designed to accommodate the extra wind loading of a wider antenna. The replacement of a tower structure is an expense that cellular communications network operators would prefer to avoid when

upgrading from a single band antenna to a dual band antenna. Also, zoning regulations can prevent of using bigger antennas in some areas.

Another attempted solution may be found in Application No. PCT EP2011/063191 to Hofmann, et al. Hofmann suggests using diplexers to combine a LTE frequency band at 2.6GHz, with a SCDMA frequency band at 1.9-2.0GHz, and applying both bands to a common radiating element. This helps reduce antenna width, but at a cost of increasing the number of coaxial transmission lines in the antenna. In the example of Figure 2 of Hofmann, eight dual polarized radiating elements are illustrated per column. For each column, there would be eight LTE coaxial lines and eight SCDMA coaxial lines, for each of two polarizations, yielding a total of 32 coaxial lines per column. Given that there are four columns illustrated, the solution of Hofmann would require 128 coaxial lines just between the phase shifters and the diplexers.

Summary

A multi-band antenna system may include an array of wide-band radiating elements and a multi-band electrical tilt circuit. The multi-band electrical tilt circuit may include a plurality of combiners, a first RF band variable phase shifter and a second RF band variable phase shifter implemented in a common medium. The common medium may comprise a PCB, a stripline circuit, or the like. Each combiner of the plurality of combiners may include a combined port, a first RF band port, and a second RF band port. The combined ports of the combiners are coupled to the array of wide-band radiating elements. The first RF band variable phase shifter has a first plurality of variably phase shifted ports connected to the first RF band ports of the plurality of combiners via transmission line, and the second RF band variable phase shifter has a second plurality of variably phase-shifted ports connected to the second RF band ports of the plurality of

combiners via transmission line. The first RF band variable phase shifter is configurable independently from the second RF band variable phase shifter.

When the common medium comprises a single printed circuit board, the plurality of combiners, at least a fixed portion of the first RF band phase shifter and at least a fixed portion of the second RF band phase shifter are fabricated as part of the single printed circuit board.

The multi-band electrical tilt circuit may further comprise a third band, fourth band, or more bands, by including a corresponding number of additional band phase shifters and additional ports on the combiners. The number of combiners may equal a number of wide-band radiating elements. The combiners may be implemented using stepped impedance microstrip on PCB. The combiners may comprise diplexers and/or duplexers.

The multi-band antenna system of claim 1 may be implemented as a dual polarized antenna system. In this example, the wide-band radiating elements comprise dual-polarized wide-band radiating elements and the multi-band electrical tilt circuit comprises a first polarization multi-band electrical tilt circuit, coupled to a first polarization element of the dual polarized wide band radiating elements, the multi-band antenna system further comprising a second polarization multi-band electrical tilt circuit coupled to a second polarization element of the dual polarized wide-band radiating elements. In another dual polarized example, there may be a first multi-band electrical tilt circuit implemented in a common medium coupled to first polarization feeds of the dual polarized wideband radiating elements, and a second multi-band electrical tilt circuit implemented in another common medium coupled to second polarization feeds of the dual polarized wideband radiating elements.

Brief Description of the Drawings

Figure 1 is a schematic view of a dual band electric tilt circuit board according to one example of the invention.

Figure 2 is a schematic view of a dual band electric tilt circuit board in the context of an antenna system.

Figure 3 is one example of a printed circuit board layout for a dual band electric tilt circuit board according to the present invention.

Figure 4 is a second example of a printed circuit board layout according to the present invention including a plurality of diplexers mounted directly on the circuit board.

Figure 5 is another view of the example of Figure 4, with cavity housings removed to reveal more detail.

Figure 6 is a detailed view of a diplexer that may be used in the printed circuit board layout of Figures 4 and 5.

Detailed Description

A multi-band electrical tilt circuit board 10 is illustrated in schematic form in Figure 1. As used herein, "multi-band" refers to two or more bands. The multi-band electrical tilt circuit board 10 includes a transmission line termination 12 for a first RF band, a transmission line termination 14 for a second RF band, a first RF band variable phase shifter 16, and a second RF band variable phase shifter 18. The transmission line termination 12 is for terminating a transmission line, such as a coaxial cable, from a radio operating in the first RF band, and transmission line termination 14 is for terminating a transmission line from a radio operating in the second RF band. There may also be transmission line terminations on the back or bottom of

the antenna system, with an intermediate cable between the termination and the multi-band electrical tilt circuit board 10. The transmission line terminations 12, 14 may comprise solder pads or a capacitive coupling. This multi-band electrical tilt circuit board 10 may be suitable for an antenna having a single polarization. In another example, two multi-band electrical tilt circuit boards 10 are employed, one for each polarization of a dual-polarized antenna.

The phase shifters 16, 18, may comprise variable differential, arcuate phase shifters as illustrated in U.S. Patent No. 7,907,096, which is incorporated by reference. In such variable phase shifters, a rotatable wiper arm variably couples an RF signal to a fixed arcuate transmission line. In the illustrated example, the phase shifters perform a 1:7 power division (which may or may not be tapered) in the direction of radio transmission, and a 7:1 combination in the direction of radio reception. One of ordinary skill in the art will readily recognize that other types of phase shifters, such as phase shifters having greater or fewer ports, may be used without departing from the scope and spirit of the invention. Herein, the terms “input” and “output” refer to the direction of RF signals when transmitting from a base station radio to the radiating elements of an antenna. However, the devices herein also operate in the receive direction, and the terms “input” and “output” would be reversed if considering RF signal flow from radiating elements to the base station radios. Taking the example of the first RF band variable phase shifter, an input is coupled to transmission line termination 12. The phase shifter has seven output ports, six of which are differentially variably phase shifted. There is also one output which maintains a fixed phase shift, however, an output having a fixed phase relationship to the input is optional.

The seven outputs of the phase shifters 16, 18 are individually coupled to seven combiners 20. Each combiner 20 has three ports: 1) a first RF band port coupled to an output of

phase shifter 16; 2) a second RF band port coupled to an output of phase shifter 18; and 3) a combined port. The first and second RF band ports of the combiner 20 are coupled to corresponding outputs on phase shifters 16, 18. For example, the first RF band port of a first combiner 20 is coupled to the first output of first RF band phase shifter 16 and the second RF band port of the first combiner 20 is coupled to the first output of second RF band phase shifter 18. In this example, the first RF band port of each combiner 20 is configured to pass signals corresponding to the first RF band, and the second RF band port of each combiner 20 is configured to pass signals corresponding to the second RF band. The combined port of each combiner 20 is coupled to a cable termination 22. The combined port is configured to pass both the first RF band and the second RF band.

The multi-band electrical tilt circuit board 10, including the phase shifters 16, 18 and combiners 20, may be implemented in a common medium. The common medium may comprise a printed circuit board, an air suspended stripline construction, or other suitable medium. In another example, the phase shifters 16, 18 may be implemented on a common medium and the combiners 20 may be fabricated separately and mounted on the common medium. For example, the combiners may be implemented as a microstrip-fed cavity filter that is soldered onto a PCB including phase shifters 16, 18.

While the multi-band electric tilt circuit board 10 of Figure 1 is illustrated as servicing two RF bands, one of ordinary skill in the art will recognize that this structure may be expanded to three or more RF bands. In such a case, the number of phase shifters, and the number of ports on the combiners, would increase with each additional band. Additionally, a multi-band electrical tilt circuit board 10 may be configured for high band or low band operation. In one example, involving low band frequencies, the first RF band may comprise 880-960 MHz and the

second RF band may comprise 790-862 MHz. In another example involving high band frequencies, the first RF band may be 1710-1880 MHz and the second RF band may be 1920 MHz – 2170 MHz. Alternatively with respect to this example, a third RF band at 2.5-2.7 GHz may be included. In another alternative embodiment, the first RF band may be 1710-2170 MHz and the second RF band may be 2.5-2.7 GHz. Additional combinations of bands are contemplated.

Referring to Figure 2, the schematic illustration of a multi-band electrical tilt circuit board 10 from Figure 1 is illustrated with coaxial connections to other components. Each antenna element 34 is coupled to a combiner 20 by way of a coaxial transmission line 32 and a cable termination 22. In some embodiments, each radiating element may be associated with a circuit board or boards for terminating coaxial transmission line 36 and for providing a balun for converting RF signals from unbalanced to balanced and back. The transmission line termination 12 terminates coaxial transmission line 36 from a radio operating in the first RF band, and transmission line termination 14 terminates coaxial transmission line 38 from a radio operating in the second RF band.

Referring to Figure 3, one example of a physical implementation of a multi-band electrical tilt circuit board 110 is illustrated. In this example, a fixed portion of a first band phase shifter 116, a second band phase shifter 118 and the diplexers 120a -120g are implemented using printed circuit board (PCB) fabrication techniques. Also illustrated are coaxial terminations 112 and 114. Rotatable wiper arms for the phase shifters 116, 118 are not illustrated to enhance clarity of the fixed portions of the phase shifters 116, 118. Most preferably, the fixed portion of the phase shifters 116, 118 and the diplexers 120a -120g are fabricated on a common PCB with

microstrip transmission lines providing the connections between the components. This allows for a significant reduction in cables required.

Referring to Figures 4 and 5, a second example of a physical implementation of a multi-band electrical tilt circuit board 210 is illustrated. In this example, each of a plurality of diplexers 220 are implemented as a microstrip-fed cavity filter including a cavity housing 240. The microstrip portion of the diplexer 220 may be fabricated on the same PCB as a fixed portion of a first band phase shifter 216 and a second band phase shifter 218. In another example, the diplexers 220 are separately fabricated PCB and cavity housing combinations, and are soldered directly to a PCB including first band phase shifter 216 and second band phase shifter 218.

The diplexers may comprise two series notch filters (see, e.g., Figs. 5 and 6) with a common port 222 in the middle, a first band input 224 at one end, and a second band input 226 at the other end. The cavity housing 240 may be machined to provide a cavity enclosing each notch filter of the diplexer 220. Tuning plugs 242 may also be included to further tune the frequency response of the notch filters. Figure 5 illustrates the multi-band electrical tilt circuit board 210 with the cavity housings 240 removed.

Referring to Figure 6, one of the diplexers 220 of Figure 5 is illustrated in detail. The diplexers 220 each have a common port 222 first band input 224, and a second band input 226. The illustrated example contains three notch filters 228a between the first band input 224 and the common port 222, and three notch filters 228b between the second band input 226 and the common port 222. The notch filters 228a, 228b, are configured to pass the first and second bands, respectively, and block other frequencies. Alternatively, the diplexers may use a number of resonant stubs that act as stop-band filters, blocking energy in specific bands. The resonant frequency most heavily depends on the length of the stub and how the stub is terminated. For

example an open-circuited stub will block frequencies such that the stub is a quarter-wavelength long while a short-circuited stub will block frequencies such that the stub is a half-wavelength long. The impedance of the stub also impacts its performance and in many cases performance either in terms of amount of rejection in dB or bandwidth in frequency are improved by dividing the stub into subsections each with its own separate impedance.

Also illustrated in Figures 4 and 5 are coaxial terminations 212 and 214. Rotatable wiper arms for the phase shifters 216, 218 are not illustrated to enhance clarity of the fixed portions of the phase shifters 216, 218. Preferably, the fixed portion of the phase shifters 216, 218 and the diplexers 220 are fabricated on a common PCB with microstrip transmission lines providing the connections between the components. This allows for a significant reduction in cables required.

The structure of the present invention permits independent adjustment of downtilt for each band. Additionally, the present invention reduces weight and cabling complexity relative to prior-known solutions.

While the invention has been described above by reference to various embodiments, it should be understood that many changes and modifications can be made without departing from the scope of the invention. It is therefore intended that the foregoing detailed description be regarded as illustrative rather than limiting, and that it be understood that it is the following claims, including all equivalents, that are intended to define the spirit and scope of this invention.

What is claimed is:

1. A multi-band antenna system, comprising:
 - a. an array of wide-band radiating elements;
 - b. a multi-band electrical tilt circuit implemented in a common medium, comprising:
 1. a plurality of combiners, each combiner having a combined port, a first RF band port, and a second RF band port, the combined ports of the combiners being coupled to the array of wide-band radiating elements;
 2. a first RF band variable phase shifter having a first plurality of variably phase shifted ports connected to the first RF band ports of the plurality of combiners via transmission line;
 3. a second RF band variable phase shifter having a second plurality of variably phase-shifted ports connected to the second RF band ports of the plurality of combiners via transmission line;

wherein said first RF band variable phase shifter is configurable independently from said second RF band variable phase shifter.

2. The multi-band antenna system of claim 1, wherein the common medium comprises a single printed circuit board, and the plurality of combiners, at least a fixed portion of the first RF band phase shifter and at least a fixed portion of the second RF band phase shifter are fabricated as part of the single printed circuit board.
3. The multi-band antenna system of claim 1, further comprising a third RF band phase shifter having a third plurality of variably phase shifted ports, and wherein each combiner

further comprises a third RF band port coupled to the third plurality of variably phase shifted ports.

4. The multi-band antenna system of claim 1, further comprising a plurality of arrays of wide-band radiating elements.
5. The multi-band antenna system of claim 1, wherein a number of combiners equals a number of wide-band radiating elements.
6. The multi-band antenna system of claim 1, wherein the wide-band radiating elements comprise dual-polarized wide-band radiating elements and the multi-band electrical tilt circuit comprises a first polarization multi-band electrical tilt circuit, coupled to a first polarization element of the dual polarized wide band radiating elements, the multi-band antenna system further comprising a second polarization multi-band electrical tilt circuit coupled to a second polarization element of the dual polarized wide-band radiating elements.
7. The multi-band antenna system of claim 1, wherein the combiners are implemented using stepped impedance microstrip on PCB.
8. The multi-band antenna system of claim 1, wherein each combiner further comprises a diplexer.

9. The multi-band antenna system of claim 1, wherein each combiner further comprises a duplexer.
10. The multi-band antenna system of claim 1, wherein the common medium comprises a stripline assembly, and the plurality of combiners, a fixed portion of the first RF band phase shifter and a fixed portion of the second RF band phase shifter are all fabricated as part of the stripline assembly.
11. A multi-band antenna system, comprising:
 - a. an array of dual polarized wide-band radiating elements, the dual polarized wide band radiating elements including a first polarization feed and a second polarization feed;
 - b. a first polarization multi-band electrical tilt circuit implemented in a first common medium, comprising:
 1. a plurality of first polarization combiners, each combiner having a combined port, a first RF band port, and a second RF band port, the combined ports of the combiners being coupled to the first polarization feed of the array of wide-band radiating elements;
 2. a first RF band first polarization variable phase shifter having a first plurality of variably phase shifted ports connected to the first RF band ports of the plurality of first polarization combiners via transmission line;
 3. a second RF band phase first polarization variable shifter having a second plurality of variably phase-shifted ports connected to the second RF band ports of the plurality of first polarization combiners via transmission line; and

b. a second polarization multi-band electrical tilt circuit implemented in a second common medium, comprising:

1. a plurality of second polarization combiners, each combiner having a combined port, a first RF band port, and a second RF band port, the combined ports of the second polarization combiners being coupled to the second polarization feed of the array of wide-band radiating elements;
2. a first RF band second polarization variable phase shifter having a first plurality of variably phase shifted ports connected to the first RF band ports of the plurality of second polarization combiners via transmission line;
3. a second RF band second polarization variable phase shifter having a second plurality of variably phase shifted ports connected to the second RF band ports of the plurality of second polarization combiners via transmission line;

wherein said first RF band variable phase shifters are configurable independently from said second RF band variable phase shifters.

12. The multi-band antenna system of claim 11, wherein each of the first and second common media comprise a single printed circuit board, and the plurality of combiners, at least a fixed portion of the first RF band phase shifter and at least a fixed portion of the second RF band phase shifter are fabricated as part of the single printed circuit board.

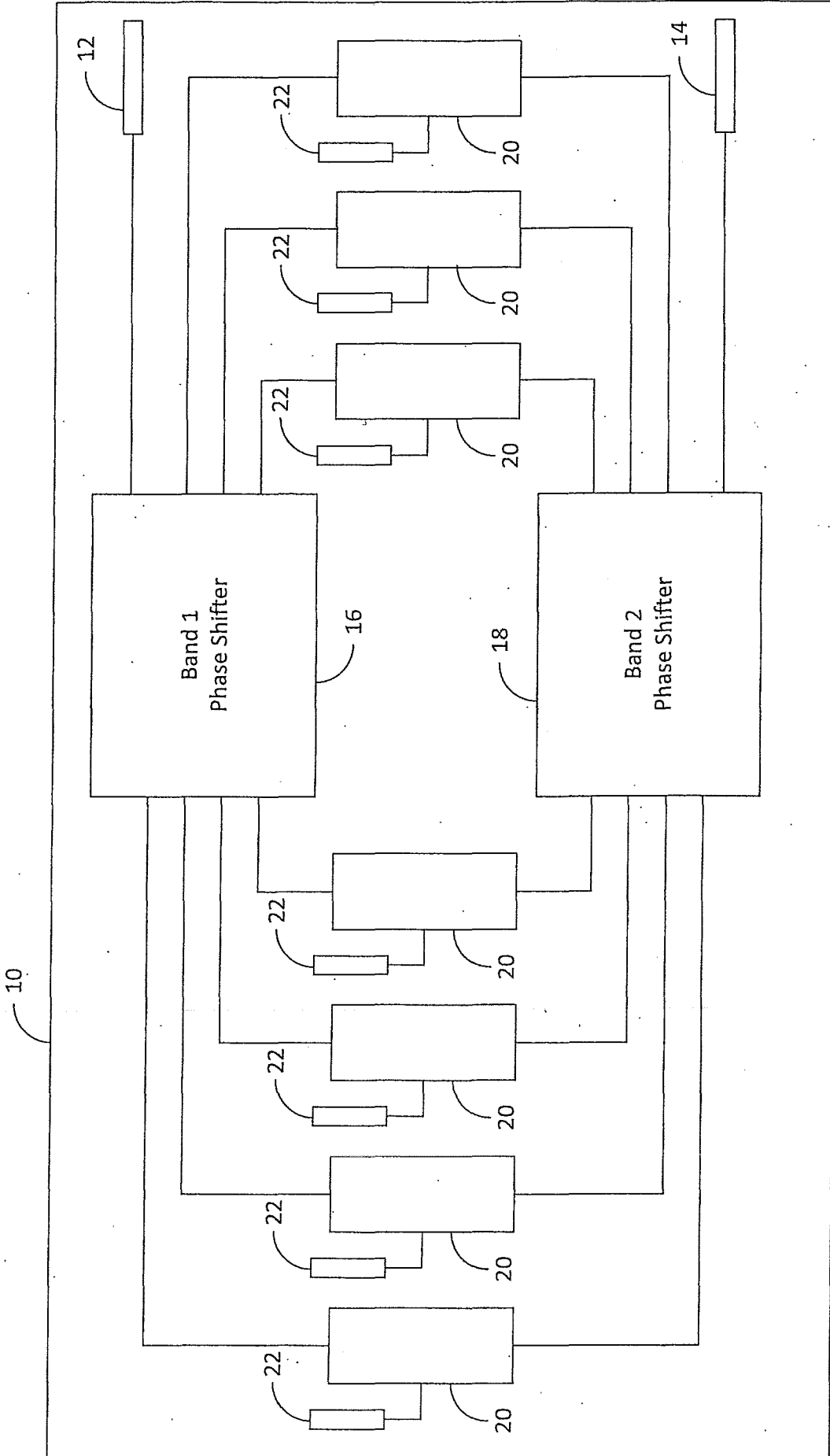

Fig. 1

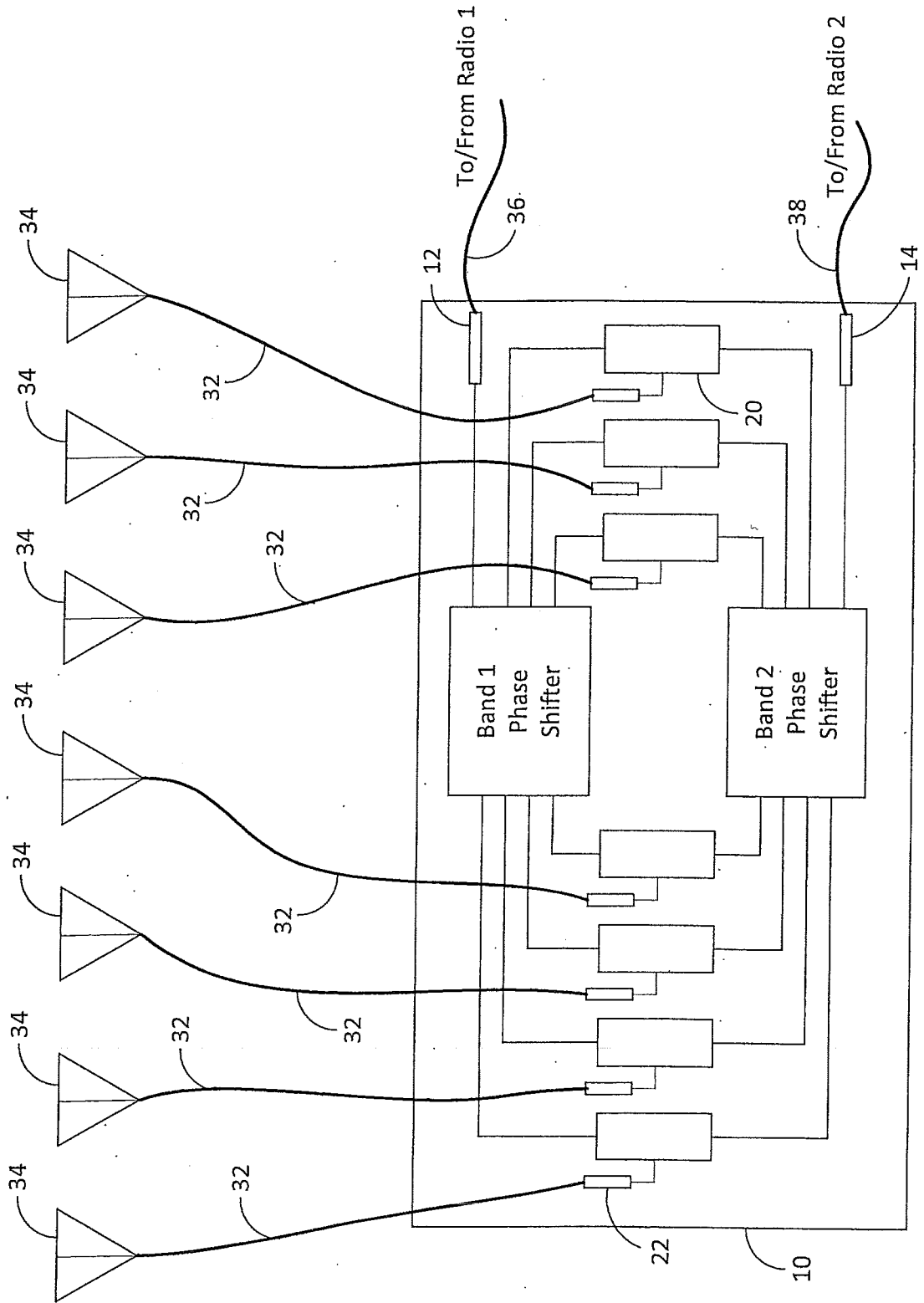

Fig. 2

110

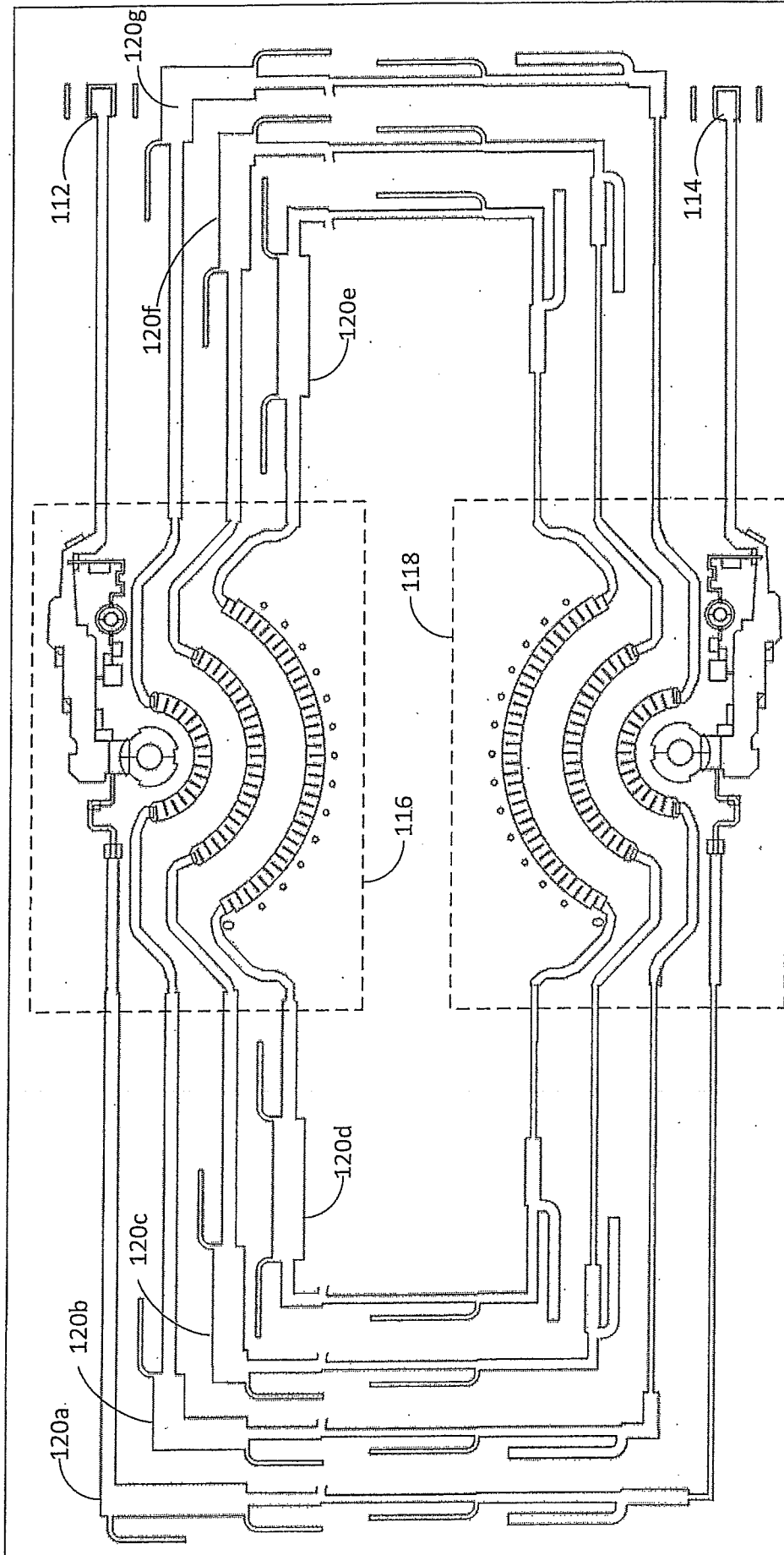

Fig. 3

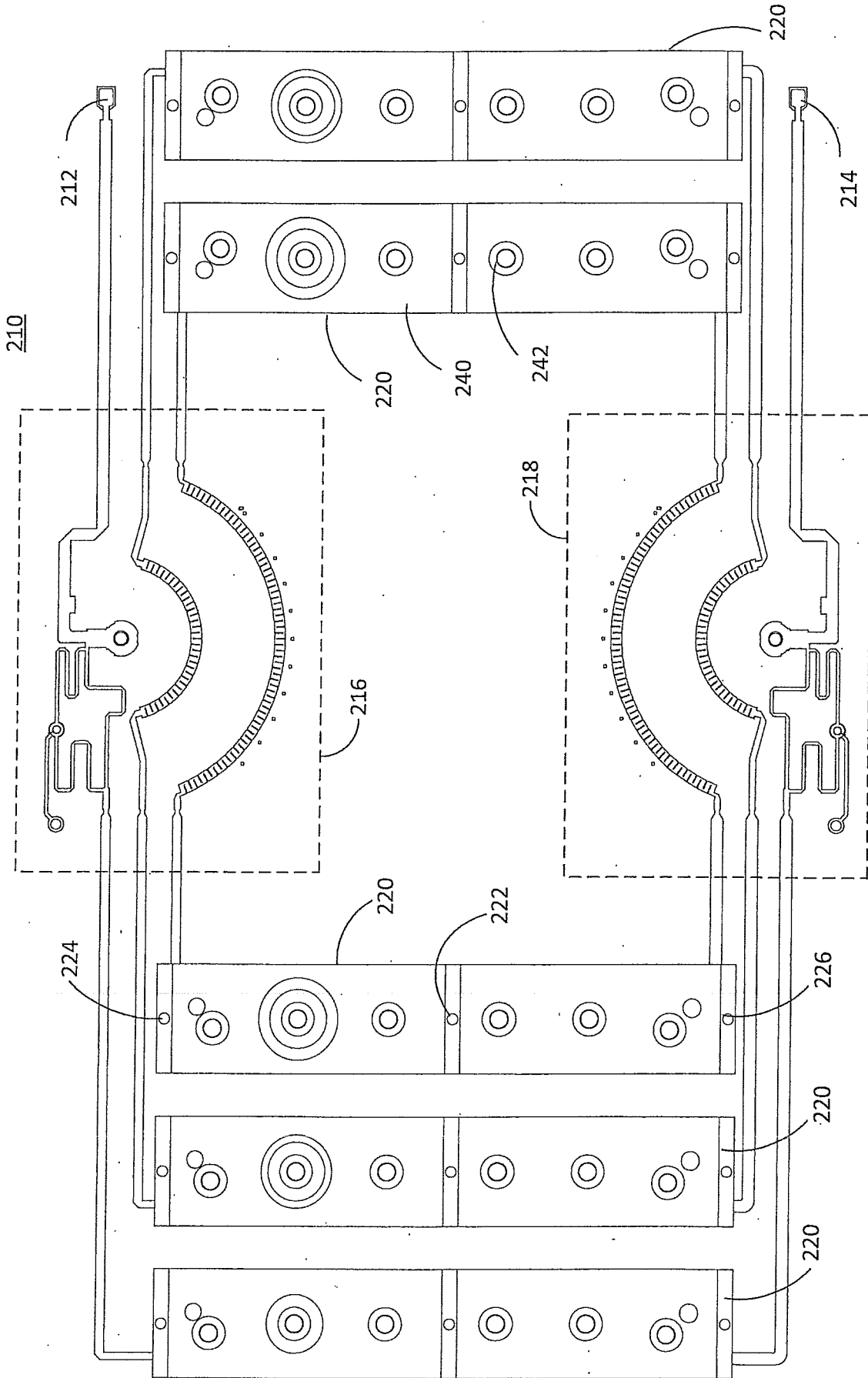

Fig. 4

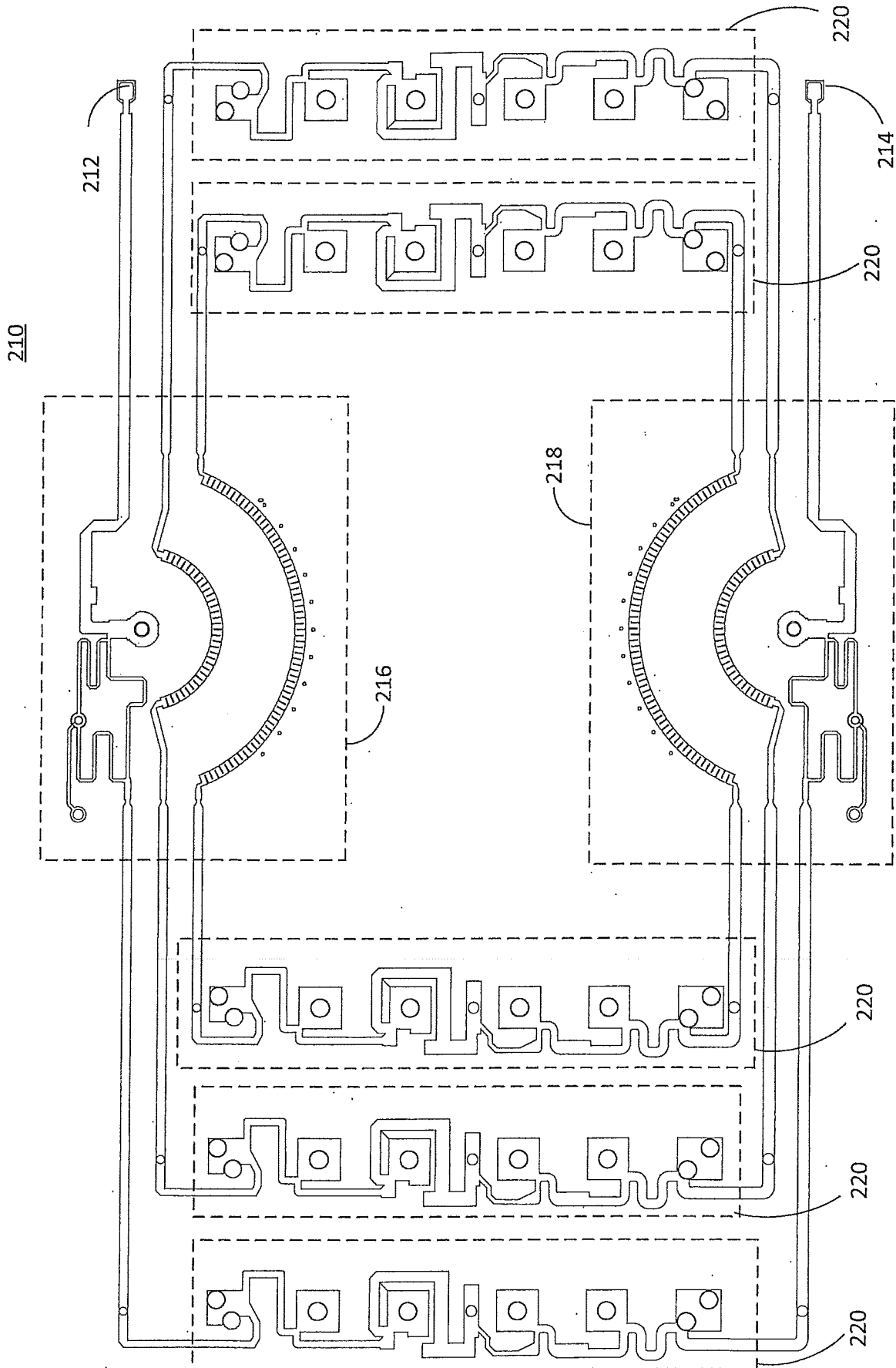

Fig. 5

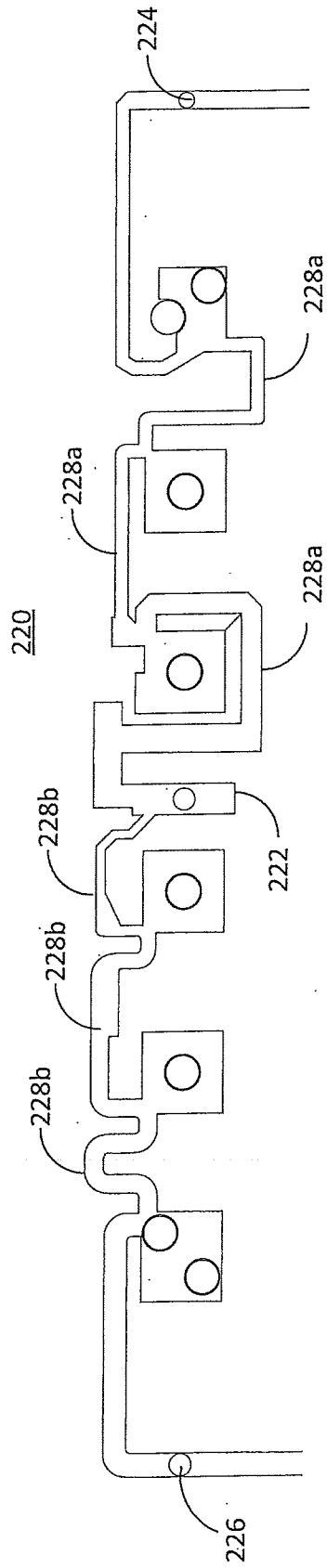

Fig. 6

INTERNATIONAL SEARCH REPORT

International application No
PCT/US2014/063882

A. CLASSIFICATION OF SUBJECT MATTER
 INV. H01Q1/24 H01P1/18 H01Q3/36 H01Q21/30 H01Q5/20
 H01Q5/28 H01Q5/50
 ADD.
 According to International Patent Classification (IPC) or to both national classification and IPC

B. FIELDS SEARCHED
 Minimum documentation searched (classification system followed by classification symbols)
 H01Q H01P

Documentation searched other than minimum documentation to the extent that such documents are included in the fields searched

Electronic data base consulted during the international search (name of data base and, where practicable, search terms used)
 EPO-Internal, WPI Data

C. DOCUMENTS CONSIDERED TO BE RELEVANT

Category*	Citation of document, with indication, where appropriate, of the relevant passages	Relevant to claim No.
Y	WO 2012/016941 A1 (NOKIA SIEMENS NETWORKS OY [FI]; HOFMANN RALF [DE]; GOLDBERG MARTIN [DE]) 9 February 2012 (2012-02-09) figures 1, 2 page 1, line 11 - line 17 page 5, line 18 - line 21 page 6, line 1 - line 8 page 6, line 10 - line 14 page 6, line 34 - line 37 page 7, line 1 - line 3 page 7, line 12 - line 20 page 7, line 25 - line 29 page 7, line 31 - line 38 page 8, line 1 - line 6 ----- -/--	1-12

Further documents are listed in the continuation of Box C.

See patent family annex.

* Special categories of cited documents :

- "A" document defining the general state of the art which is not considered to be of particular relevance
- "E" earlier application or patent but published on or after the international filing date
- "L" document which may throw doubts on priority claim(s) or which is cited to establish the publication date of another citation or other special reason (as specified)
- "O" document referring to an oral disclosure, use, exhibition or other means
- "P" document published prior to the international filing date but later than the priority date claimed

- "T" later document published after the international filing date or priority date and not in conflict with the application but cited to understand the principle or theory underlying the invention
- "X" document of particular relevance; the claimed invention cannot be considered novel or cannot be considered to involve an inventive step when the document is taken alone
- "Y" document of particular relevance; the claimed invention cannot be considered to involve an inventive step when the document is combined with one or more other such documents, such combination being obvious to a person skilled in the art
- "&" document member of the same patent family

Date of the actual completion of the international search

29 January 2015

Date of mailing of the international search report

09/02/2015

Name and mailing address of the ISA/

European Patent Office, P.B. 5818 Patentlaan 2
 NL - 2280 HV Rijswijk
 Tel. (+31-70) 340-2040,
 Fax: (+31-70) 340-3016

Authorized officer

Yvonnet, Yannick

INTERNATIONAL SEARCH REPORT

International application No
PCT/US2014/063882

C(Continuation). DOCUMENTS CONSIDERED TO BE RELEVANT		
Category*	Citation of document, with indication, where appropriate, of the relevant passages	Relevant to claim No.
Y	US 2005/046514 A1 (JANOSCHKA DARIN M [US]) 3 March 2005 (2005-03-03) figure 15 paragraph [0002] paragraph [0044] paragraph [0072]	1-12
Y	----- WO 2012/048343 A1 (COMMSCOPE INC [US]) 12 April 2012 (2012-04-12) paragraph [0005] paragraph [0006] paragraph [0018] figure 2 -----	9

INTERNATIONAL SEARCH REPORT

Information on patent family members

International application No PCT/US2014/063882

Patent document cited in search report	Publication date	Patent family member(s)	Publication date
WO 2012016941 A1	09-02-2012	EP 2601708 A1	12-06-2013
		US 2013294302 A1	07-11-2013
		WO 2012016941 A1	09-02-2012

US 2005046514 A1	03-03-2005	AU 2004269748 A1	10-03-2005
		BR PI0413398 A	17-10-2006
		CA 2537265 A1	10-03-2005
		CN 1864302 A	15-11-2006
		EP 1665338 A2	07-06-2006
		JP 2007508723 A	05-04-2007
		MX PA06002149 A	22-05-2006
		US 2005046514 A1	03-03-2005
		WO 2005022601 A2	10-03-2005

WO 2012048343 A1	12-04-2012	CN 103168389 A	19-06-2013
		EP 2596547 A1	29-05-2013
		US 2012087284 A1	12-04-2012
		WO 2012048343 A1	12-04-2012
