

Sept. 5, 1933.

W. H. TUCKER
ELECTRIC VIBRATOR
Filed July 18, 1931

1,925,350

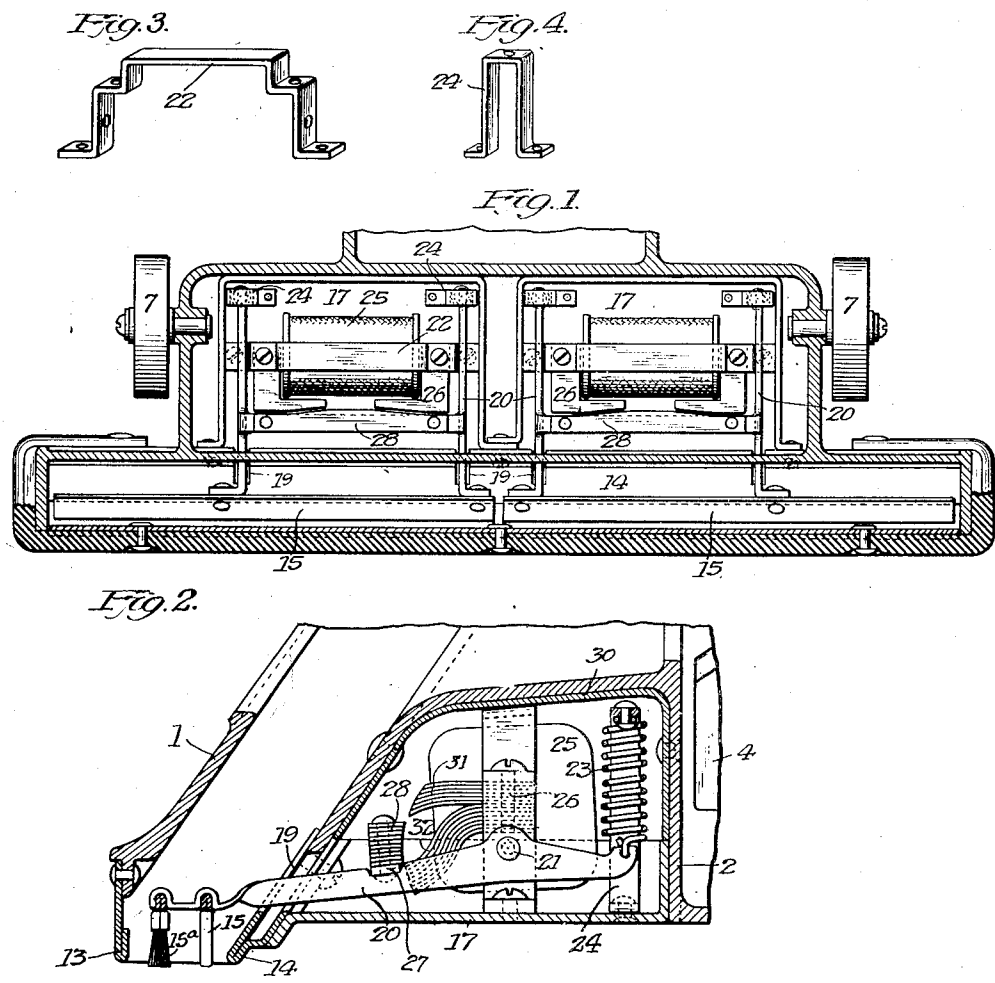

Witness
W. H. Tucker

Inventor:
W. H. Tucker
By *Harry S. Bunnell*
Atty.

UNITED STATES PATENT OFFICE

1,925,350

ELECTRIC VIBRATOR

Wilmer H. Tucker, North Canton, Ohio, assignor
to The Hoover Company, North Canton, Ohio,
a corporation of Ohio

Application July 18, 1931. Serial No. 551,676

5 Claims. (Cl. 175—338)

The present invention relates to a new and improved means for actuating a surface-agitating element in a suction cleaner. More specifically the invention comprises the provision of a new and improved electric vibrator.

It is an object of the present invention to provide a new and improved agitator-actuating means for a suction cleaner. A further object is the provision of a new and improved electric vibrator adapted to actuate a surface-covering-beating means in a suction cleaner. A still further object is the provision of an electric vibrator for a suction cleaner in which no electrical switch is present, and in which there is no audible chatter resulting from the contact of metal upon metal. These and other more specific objects will appear upon reading the following specification and claims, and upon considering in connection therewith with the attached drawing to which they relate.

In the drawing in which a preferred embodiment of the present invention is disclosed:

Figure 1 is a partial cross section upon a horizontal plane through a suction cleaner showing the present invention embodied therein, and connected to surface-agitating means in the cleaner nozzle;

Figure 2 is a section at right angles to Figure 1 and shows a vertical cross-section through a cleaner with an electric vibrator, constructed in accordance with the present invention, operatively connected to a second type of surface-agitating means in the cleaner nozzle;

Figure 3 is a view in perspective of a member by which the electric coil and stationary poles of the vibrator are supported in the cleaner construction;

Figure 4 is a view of a spring support.

An electrical vibrator constructed in accordance with the present invention finds usefulness in connection with surface-agitating means in a suction cleaner and accordingly in the drawing has been shown in connection therewith. The entire suction cleaner has not been shown, but a sufficient part thereof is illustrated to adequately indicate the position of the vibrator relative to the remainder of the machine and to the surface-agitating elements in connection with which it finds its usefulness. In the drawing a cleaner nozzle is found indicated by the reference character 1, and the cleaner fan chamber, to which the nozzle is interiorly connected, by the character 2, there being a rotatable fan 4 positioned within the fan chamber. Surface-contacting nozzle lips 13 and 14 define the nozzle mouth under which

and between which cleaning air passes on its way to the fan chamber 2 in the operation of the cleaner. The supporting wheels for the front end of the cleaner are shown and are indicated by the reference character 7, 7. Between the nozzle mouth and the fan chamber 2, in that recess formed where the nozzle extends upwardly to the eye of the fan chamber, is positioned the electric vibrator which comprises the present invention.

A bottom plate 17 is provided which extends from the rear lip 14 to the nozzle to the front of the fan chamber and provides a suitable base support therefor. Upon this bottom plate 17 is positioned a U-shaped member 22 which rigidly supports the wound coil 25 and the laminated core 26 of the vibrator. The core 26 is provided with arms which extend forwardly and partially encircle the forward or nozzle side of the coil 25, forming poles.

Upon each of the vertical sides of the U-shaped member 22, and at the sides of the vibrator coil, are pivoted arms 20, 20, each upon a pivot pin 21. These arms or links 20, 20 are connected forward of the poles 25 by a transversely-extended member 27, upon which is mounted a laminated armature 28.

In the vibrator constructed in accordance with the present invention each end of the core 26 of the coil 25 is divided and forms two pole divisions of the same polarity and which bear the reference characters 31 and 32, respectively. See Figure 2 of the drawing in particular. The armature 28 is so mounted relative to the poles 31 and 32 that it is adapted to move in close proximity thereto upon the pivotal movement of the arms 20, 20 about their pivot points 21, 21. The sides of the poles 31 and 32 which lie adjacent the path of the armature 28 are curved, as is clearly shown in Figure 2, so as to lie closely adjacent the path of armature, but without interference therewith.

Rearwardly of the pivot points 21, 21 and of the coil 25 the arms 20, 20 are secured to springs 23, 23, which are also supported from the bottom plate 17 by means of small U-shaped supports 24, 24. These springs are so designed that in the inoperative relationship of the vibrator the armature 28 is supported and held substantially midway between the poles 31 and 32 and movement toward either pole division 31 or 32, that is, either upwardly or downwardly, results in the placing of the springs under either tension or compression.

The arms 20, 20 are also extended forward of the armature 28 and through openings 19, 19 into the nozzle where they carry suitable surface-agi-

tating elements. In Figure 1 of the drawing a plurality of vibrators are shown each being connected to a rigid beating member 15. In Figure 2, however, the arms 20, 20 of the vibrator carry not only a rigid beating member 15, but also a brush 15a. The openings 19, 19 to which the arms 20, 20 extend into the nozzle are of sufficient dimensions to permit the movement of the arms 20, 20 under the action of the vibrator.

In the operation of the described construction the surface covering undergoing cleaning would be lifted against the nozzle lips 13 and 14 by the action of the suction-creating fan 4 which creates a reduced pressure within the nozzle. The beater element 15, and in the case of Figure 2, 15 and 15a, would be slightly raised by the lifted surface covering thereby moving the armature 28 in the direction of the pole division 31 of the core 26. With the coil 25 energized, as it would be in the operative relationship, and with armature 28 slightly displaced toward pole 31, upon the current passing through its maximum value, an alternating current being assumed, armature 28 would be drawn to a position adjacent pole 31, placing springs 23, 23 under tension. Upon the reversal of current and the consequent reduction in flux, the spring 23 at each link 20 would force armature 28 downwardly, thru pivoting the links and the momentum acquired by the armature would carry it in the direction of poles 32 past the mid-point and, as the current again increased to maximum value, armature 28 would be drawn in the direction of pole 32 placing each spring 23 under compression. In the next half cycle of current the operation would be reversed, the armature again being moved to the poles 31 at the opposite ends of the core 26. This, of course, results in the alternate lifting and forcing downwardly of the beating elements comprising the rigid beater 15, or beater and brush 15 and 15a, as the case may be. As is evident from the above description both the beating blow of the agitating elements and the lifting force is effected by the magnetic vibrator. By correctly designing the weight of the moving parts and the strength of the springs 23, 23 it is clear that an extremely efficient vibrating unit can be produced.

I claim:

1. An electric vibrator comprising spaced stationary poles of opposite polarities, an alternating current winding adapted to reverse the polarities of said poles, each of said poles being divided, a movable armature extending between said poles and mounted for movement toward and from each division of each pole, and resilient means opposing the movement of said armature on either side of a mid-position between the divisions of each pole and adapted to reverse the direction of travel of said armature upon the reversal of polarity of said poles caused by said winding.

2. An electric vibrator comprising a winding, a stationary core for said winding the ends of which

form poles of opposite polarity and which are divided, each division being positioned in the same plane as a division of the opposite pole, a pivoted armature extended between said poles and adapted to move in a path closely adjacent said divisions, said armature adapted to be drawn toward a pair of pole divisions of opposite polarity upon the passing of alternating current thru said winding, and means to force said armature from said pair of pole divisions toward the remaining pair of divisions upon the reversal of current in said winding and the accompanying decrease in magnetic flux of said poles so that upon the following increase in flux strength said armature will be drawn toward said remaining pair of pole divisions.

3. An electric vibrator comprising spaced stationary poles of opposite polarities, means adapted to vary the strength of said poles and simultaneously reverse their polarities, each of said poles being divided, an armature extended between pole-divisions of opposite polarities and mounted for movement toward and from divisions of the same polarity, characterized by the fact that said armature is drawn to a position between a pair of pole-divisions of opposite polarities as the pole strengths are increased to a maximum and is released from that position as the pole strength is decreased to a minimum.

4. An electric vibrator comprising spaced stationary poles of opposite polarities, a current-carrying winding adapted to vary the strength of said poles in cycles between a maximum and a minimum value, each of said poles being divided into spaced divisions, an armature extended between pole-divisions of opposite polarities and mounted for movement in a path including positions closely adjacent, but out of contact with, said pole-divisions, characterized by the fact that said armature is drawn to a position between a pair of pole-divisions of opposite polarities as the pole strengths are increased to a maximum and is released from that position as the pole strength is decreased to a minimum.

5. An electric vibrator comprising spaced stationary poles of opposite polarities, an alternating-current-carrying winding adapted to vary the strength of said poles in cycles between a maximum and a minimum value, said poles being divided into spaced divisions, an armature extended between pole-divisions of opposite polarities and mounted for movement in a path including positions closely adjacent, but out of contact with, said pole-divisions, characterized by the fact that said armature is drawn to a position between a pair of pole-divisions of opposite polarities as the pole strengths are increased to a maximum and means are provided to reverse the direction of armature travel as said pole strength is decreased to a minimum.

WILMER H. TUCKER.

65

140

70

145

75

150