

(12) STANDARD PATENT
(19) AUSTRALIAN PATENT OFFICE

(11) Application No. **AU 2010286957 B2**

(54) Title
Cassette with infusion set containing spring-biased anti-freeflow mechanism for peristaltic infusion pump

(51) International Patent Classification(s)
A61M 5/142 (2006.01) **A61M 39/28** (2006.01)
A61M 5/36 (2006.01)

(21) Application No: **2010286957** (22) Date of Filing: **2010.07.08**

(87) WIPO No: **WO11/025589**

(30) Priority Data

(31) Number	(32) Date	(33) Country
61/238,386	2009.08.31	US

(43) Publication Date: **2011.03.03**

(44) Accepted Journal Date: **2015.10.01**

(71) Applicant(s)
Nestec S.A.

(72) Inventor(s)
Hariharsan, Seralaathan;Higgins, James Allen;West, David Woodruff

(74) Agent / Attorney
Shelston IP, L 21 60 Margaret St, Sydney, NSW, 2000

(56) Related Art
US 5257978
WO 1998/013080
EP 1557187
US 2008/095649

(19) World Intellectual Property Organization
International Bureau



(43) International Publication Date
3 March 2011 (03.03.2011)

(10) International Publication Number
WO 2011/025589 A1

- (51) International Patent Classification:
A61M 5/142 (2006.01) A61M 39/28 (2006.01)
A61M 5/36 (2006.01)
- (21) International Application Number:
PCT/US2010/041323
- (22) International Filing Date:
8 July 2010 (08.07.2010)
- (25) Filing Language: English
- (26) Publication Language: English
- (30) Priority Data:
61/238,386 31 August 2009 (31.08.2009) US
- (71) Applicant (for all designated States except US):
NESTEC S.A. [CH/CH]; Avenue Nestle 55, CH-1800
Vevey (CH).
- (72) Inventors; and
- (75) Inventors/Applicants (for US only): HARIHARESAN,
Seralathan [IN/US]; 1405 San Jacinto Drive, Flower

Mound, Texas 75028 (US). HIGGINS, James Allen [US/US]; 4548 Saint James Drive, Plano, Texas 75024 (US). WEST, David Woodruff [US/US]; 203 North Morris Street, McKinney, Texas 75069 (US).

(74) Agent: LOBEL, Gary M.; Nestle HealthCare Nutrition, 12 Vreeland Road, 2nd Floor, Florham Park, New Jersey 07932 (US).

(81) Designated States (unless otherwise indicated, for every kind of national protection available): AE, AG, AL, AM, AO, AT, AU, AZ, BA, BB, BG, BH, BR, BW, BY, BZ, CA, CH, CL, CN, CO, CR, CU, CZ, DE, DK, DM, DO, DZ, EC, EE, EG, ES, FI, GB, GD, GE, GH, GM, GT, HN, HR, HU, ID, IL, IN, IS, JP, KE, KG, KM, KN, KP, KR, KZ, LA, LC, LK, LR, LS, LT, LU, LY, MA, MD, ME, MG, MK, MN, MW, MX, MY, MZ, NA, NG, NI, NO, NZ, OM, PE, PG, PH, PL, PT, RO, RS, RU, SC, SD, SE, SG, SK, SL, SM, ST, SV, SY, TH, TJ, TM, TN, TR, TT, TZ, UA, UG, US, UZ, VC, VN, ZA, ZM, ZW.

[Continued on next page]

(54) Title: CASSETTE WITH INFUSION SET CONTAINING SPRING-BIASED ANTI-FREEFLOW MECHANISM FOR PERISTALTIC INFUSION PUMP

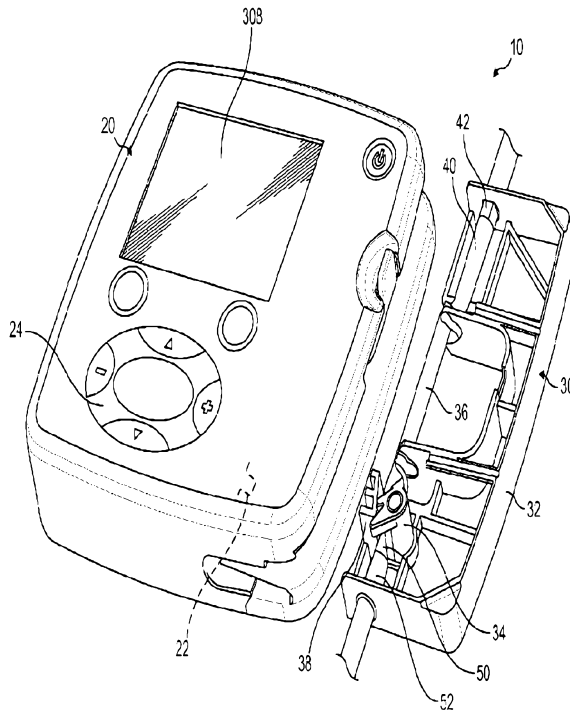

FIG. 1

(57) Abstract: Flow control devices.- In a general embodiment, the present disclosure provides a cassette (30) comprising a housing having a flow restrictor (34), and a tube (36) attached to the housing and positioned adjacent the flow restrictor. The flow restrictor may be so constructed and arranged to rotate from a first position in which the flow restrictor prevents fluid flow through the tube to a second position in which fluid is able to flow through the tube when the cassette is positioned inside a pumping device. As a result, the cassette is designed to prevent free flow of fluid when an enteral feeding tube set is not installed in a pumping device.

WO 2011/025589 A1



(84) Designated States (unless otherwise indicated, for every kind of regional protection available): ARIPO (BW, GH, GM, KE, LR, LS, MW, MZ, NA, SD, SL, SZ, TZ, UG, ZM, ZW), Eurasian (AM, AZ, BY, KG, KZ, MD, RU, TJ, TM), European (AL, AT, BE, BG, CH, CY, CZ, DE, DK, EE, ES, FI, FR, GB, GR, HR, HU, IE, IS, IT, LT, LU, LV, MC, MK, MT, NL, NO, PL, PT, RO, SE, SI, SK, SM, TR), OAPI (BF, BJ, CF, CG, CI, CM, GA, GN, GQ, GW, ML, MR, NE, SN, TD, TG).

— as to applicant's entitlement to apply for and be granted a patent (Rule 4.17(ii))

— as to the applicant's entitlement to claim the priority of the earlier application (Rule 4.17(iii))

Published:

— with international search report (Art. 21(3))

— before the expiration of the time limit for amending the claims and to be republished in the event of receipt of amendments (Rule 48.2(h))

Declarations under Rule 4.17:

— as to the identity of the inventor (Rule 4.17(i))

CASSETTE WITH INFUSION SET CONTAINING SPRING-BIASED ANTI-FREEFLOW MECHANISM FOR PERISTALTIC INFUSION PUMP

BACKGROUND

[0001] The present disclosure generally relates to health and nutrition. More specifically, the present disclosure relates to flow control devices and methods of using the flow control devices.

[0002] Any discussion of the prior art throughout the specification should in no way be considered as an admission that such prior art is widely known or forms part of common general knowledge in the field.

[0003] The delivery of nutritional compositions to mammals, such as human patients, that cannot orally ingest food or other forms of nutrition is often of critical importance. For example, enteral bottles and containers having feeding tubes that deposit food directly into the gastrointestinal tract at a point below the mouth are often used to sustain life while a patient is unable, or refuses, to take food orally. Bottles and containers, feeding tubes and other artificial delivery systems and routes can be used temporarily during the treatment of acute medical conditions. For chronic medical conditions, such systems and routes can be used as part of a treatment regimen that lasts for the remainder of a patient's life. No matter the duration of use, these devices often provide the only means for feeding the patient.

[0004] The use of enteral feeding pumps, in conjunction with an enteral feeding tube set as part of an enteral feeding system, for the administering of medical fluids is also well known in the medical arts. The enteral feeding tube set will typically include several long sections of tubing, connected to a centralized, shorter section of tubing. One common concern with the enteral feeding tube set is that fluid flow from a nutritional source through the enteral feeding tube set may begin before the feeding tube set is connected to an enteral administration pump. As a result, the nutritional fluid may spill out of the tube set or be administered to a patient before the desired time.

SUMMARY

[0005] According to a first aspect, the invention provides a cassette for being positioned within a pumping device comprising:

a housing comprising a flow restrictor comprising a locking member, a peg that is

attached to the housing and a spring; and

a flexible tube comprising a first end attached to an inlet port and a second end attached to an outlet port of the housing, a flexible tube being positioned adjacent the flow restrictor and a stopper, the stopper being arranged on an opposite side of the tube from the flow restrictor, the locking member being constructed and arranged to rotate from a first resting position that restricts fluid flow through the tube to a second actuated position that allows fluid flow through the tube, wherein the locking member and the spring are arranged to rotate about a common axis of rotation that is shared with the peg.

[0006] Unless the context clearly requires otherwise, throughout the description and the claims, the words “comprise”, “comprising”, and the like are to be construed in an inclusive sense as opposed to an exclusive or exhaustive sense; that is to say, in the sense of “including, but not limited to”.

[0007] The present disclosure relates to flow control devices and methods of using the flow control devices. In a preferred embodiment, the present disclosure provides a cassette including a housing having a flow restrictor including a locking member and a spring, and a tube attached to the housing and positioned adjacent the flow restrictor. The flow restrictor acts to occlude the tube and form a flow restriction mechanism in the cassette.

[0008] The tube includes a first end attached to an inlet port and a second end attached to an outlet port. Any suitable portion of the tube can be flexible. In this regard, the cassette can be part of an enteral feeding tube set that includes tubing connected to the nutritional composition and to a person receiving the nutritional composition. Advantageously, the cassette is designed to prevent free flow of fluid through the feeding tube set when the feeding tube set is not installed in a pumping device.

[0009] Preferably, the locking member of the flow restrictor is constructed and arranged to rotate from a first position that occludes the tube to a second position that allows fluid to flow through the tube when inserted into a pumping device. As a result, the flow restriction mechanism can be disengaged (e.g., allow fluid flow) for manual priming of the tube set and disengaged when the feeding tube set is installed into a pumping device.

[0010] Advantageously, the flow restrictor and the stopper operate in conjunction to occlude the tube when the flow restrictor is in a resting position and to allow fluid to flow through the tube when the flow restrictor is in an actuated position.

[0011] According to a second aspect, the invention provides a flow control system comprising:

a cassette according to the first aspect, and

a pumping device comprising an actuation member;

wherein the cassette is removably attached to the pumping device, and wherein the flow restrictor of the cassette is so constructed and arranged to align with the actuation member of the pumping device when the cassette is positioned within the pumping device.

[0012] In another preferred embodiment, the present disclosure provides a flow control system including a pumping device having a projection and a cassette removably attached to the pumping device. The projection may be an actuation member. The cassette includes a housing having a flow restrictor so constructed and arranged to align with the projection or, in an embodiment, the actuation member, when the cassette is inserted into the pumping device. A flexible tube is attached to the housing and positioned adjacent the flow restrictor. The alignment of the flow restrictor and the projection, or actuation member, causes actuation of the flow restrictor. In an embodiment, the actuation of the flow restrictor includes rotation of the flow restrictor. The flow restrictor may include a locking member and a spring. The flow restrictor may further include a peg attached to the housing. The locking member of the flow restrictor may include an occluding portion and an actuating portion.

[0013] In a preferred embodiment, the flexible tube can include a first end attached to an inlet port and a second end attached to an outlet port. Any suitable portion of the tube can be flexible.

[0014] According to another aspect, the invention provides a method of controlling fluid flow in a tube, the method comprising:

providing a cassette comprising 1) a housing having a flow restrictor and a stopper, wherein the flow restrictor comprises a locking member, a spring and a peg that is attached to the housing and 2) a flexible tube comprising a first end attached to an inlet port and a second end attached to an outlet port of the housing and positioned adjacent the flow restrictor and the stopper, the stopper being arranged on an opposite side of the tube from the flow restrictor;

occluding fluid flow through the tube by positioning an occluding portion of the flow restrictor at a location proximate the stopper; and

passing fluid through the tube by positioning the occluding portion of the flow restrictor at a location away from the stopper, wherein positioning of the occluding portion is

obtained by rotation of said locking member about a common axis with said spring of the flow restrictor, wherein the common axis is shared with said peg.

[0015] In a further preferred embodiment, the occluding portion of the flow restrictor is positioned at a location away from the stopper when the cassette is positioned inside a pumping device. For example, an actuating portion of the flow restrictor may be contacted by an actuation member of the pumping device to rotate the flow restrictor. When the flow restrictor is rotated, the occluding portion is also rotated to a location away from the stopper, which allows fluid to flow through the flexible tube.

[0016] Advantageously, the present disclosure provides an improved flow control device.

[0017] Advantageously, the present disclosure provides an improved enteral feeding cassette having a flow restriction mechanism.

[0018] More advantageously, the present disclosure provides an improved method of preventing fluid flow through an enteral feeding cassette when the cassette is not attached to a pumping device.

[0019] Advantageously, the present disclosure provides an improved method of controlling flow during enteral feeding.

[0020] Additional features and advantages are described herein, and will be apparent from the following Detailed Description and the figures.

BRIEF DESCRIPTION OF THE FIGURES

[0021] FIG. 1 shows a pumping device and a cassette having a flow restriction mechanism in an embodiment of the present disclosure.

[0022] FIG. 2 shows the pumping device and the cassette of FIG. 1 with the cassette inserted into the pumping device.

[0023] FIG. 3 shows a cassette having a flow restriction mechanism in an embodiment of the present disclosure.

[0024] FIG. 4 shows an exploded view of a cassette having a flow restriction mechanism in an embodiment of the present disclosure.

DETAILED DESCRIPTION

[0025] The present disclosure relates to flow control devices and methods of using the flow control devices. In a general embodiment, the present disclosure provides a cassette including a housing having a flow restrictor, and a tube attached to the housing and positioned adjacent the flow restrictor. The flow restrictor may include a locking member in combination with a spring and/or a peg that is attached to the housing. In this configuration, the locking member of the flow restrictor is so constructed and arranged to rotate from a first position that restricts fluid flow through the tube to a second position that allows fluid to flow through the tube. The arrangement of the locking member in the first position restricts fluid flow through the tube when the cassette is not in use. The cassette can be part of an enteral administration device or system that administers nutritional compositions to a person or patient in need of same.

[0026] The cassette that includes the flow restriction mechanism provides the user an elegant way to install the flow restriction mechanism and feeding tube set into a pumping device via features built into a housing of the cassette and may also provide other built in functionality for successful delivery of the nutritional composition to a person or patient. The flow restriction mechanism prevents leakage/flow of the nutritional composition in the enteral feeding tube set, for example, in the following instances: 1) before and after the feeding tube set is primed with the feeding fluid, 2) during the loading and unloading of the feeding tube set into and out of the pumping device and 3) after the feeding tube set has been removed from the pumping device.

[0027] As used herein, the term "nutritional composition" includes, but is not limited to, complete nutritional compositions, partial or incomplete nutritional compositions, and disease or condition specific nutritional compositions. A complete nutritional composition (i.e., those which contain all the essential macro and micro nutrients) can be used as a sole source of nutrition for the patient. Patients can receive 100% of their nutritional requirements from such complete nutritional composition. A partial or incomplete nutritional composition does not contain all the essential macro and micro nutrients and cannot be used as a sole source of nutrition for the patient. Partial or incomplete nutritional compositions can be used as nutritional supplements.

[0028] In an embodiment illustrated in FIGS. 1-2, the present disclosure provides a flow control system 10 including a pumping device 20 having an actuation member 22. Flow control system 10 further includes a cassette 30 removably attached to pumping device 20. The design of cassette 30 can help in loading an enteral feeding tube set (not shown) into pumping device 20 without having to route/guide the tubes or stretch the tubes from the tube set over a rotor (e.g., part of a peristaltic pump).

[0029] Pumping device 20 can be an enteral feeding pump. Non-limiting examples of pumping devices are described in U.S. Patent No. 6,659,976, which is incorporated herein by reference. Pumping device 20 can include a monitor/information screen 21 and a control pad 24 for operating pumping device 20.

[0030] Cassette 30 can have any suitable shape such as the one shown in FIGS. 1 and 3-4 and is design to be positioned within pumping device 20. Non-limiting examples of alternative cassette configurations are described in U.S. Patent Nos. D504,506, D505,199, D455,489, D501,924 and D507,647, which are incorporated herein by reference. Cassette 30 can be made from any suitable rigid, semi-rigid or flexible material. Cassette 30 can also be “keyed/poka yoked” such that it can be inserted into pumping device 20 only one way.

[0031] As illustrated in FIGS. 1-2, cassette 30 includes a housing 32 having a flow restrictor 34 constructed and arranged to align with actuation member 22 of pumping device 20 when cassette 30 is inserted into pumping device 20. Housing 32 further includes a stopper 38 located or positioned adjacent flexible tube 36 on a side of flexible tube 36 opposite flow restrictor 34. Flexible tube 36 is attached to housing 32 and positioned adjacent flow restrictor 34. Flexible tube 36 can be made of any suitable materials such as silicone. It should be appreciated that any suitable portion of flexible tube 36 can be flexible while the remaining portion is rigid or semi-rigid.

[0032] Flexible tube 36 can include a first end 40 attached to an inlet port 42 and a second end 50 attached to an outlet port 52. As a result, fluid can flow through flexible tube 36 in the direction from first end 40 to second end 50. Inlet port 42 can be attached to a tube connected to a nutritional composition source. Outlet port 52 can be attached to a tube connected to the person receiving the nutrition composition.

[0033] As is shown in FIG. 4, in an embodiment, flow restrictor 34 includes a locking member 34a, a spring 34b and a peg 34c that is attached to housing 32. Locking member 34a includes an occluding portion 44 and an actuating portion 46. As mentioned above, flow restrictor 34 is so constructed and arranged to align with actuation member 22 of pumping

device 20. Specifically, actuating portion 46 of flow restrictor 34 is so constructed and arranged to be contacted by actuation member 22 to rotate flow restrictor 34. Although shown as substantially rectangular in shape, actuation member 22 may have any shape or size that is sufficient to contact and rotate flow restrictor 34. For example, actuation member 22 may have a shape that is square, rectangular, triangular, oblong, parabolic, etc. Likewise, it will also be understood that actuating portion 46 of flow restrictor 34 may have any shape or size that is sufficient to be contacted and rotated by actuation member 22. For example, actuating portion 46 may have a shape that is square, rectangular, triangular, oblong, parabolic, etc. Further, the skilled artisan will also appreciate that occluding portion 44 of flow restrictor 34 may have any shape or size that is sufficient to occlude flexible tube 36 by pressing flexible tube 36 against stopper 38. For example, actuating portion 46 may have a shape that is square, rectangular, triangular, oblong, parabolic, etc.

[0034] During operation, when cassette 30 is inserted into pumping device 20, actuation member 22 will contact actuating portion 46 of locking member 34a. Upon continued insertion into pumping device 20, actuation member 22 will actuate flow restrictor 34. In an embodiment, actuation member 22 actuates flow restrictor 34 by pushing actuating portion 46 of locking member 34a in a direction that is away from pumping device 20 to rotate locking member 34a counter-clockwise. Locking member 34a and spring 34b rotate about a common axis of rotation that is shared with peg 34c. The skilled artisan will appreciate that locking member 34a need not rotate counter-clockwise. Rather, in another embodiment, locking member 34a may rotate clockwise.

[0035] In an embodiment where flow restrictor 34 is actuated by rotation, flow restrictor 34 rotates from a first, or resting position, as shown in FIGS. 1 and 3, to a second, or actuated position (not shown) as cassette 30 is inserted into pumping device 20. In the first, or resting position, flow restrictor 34 is located proximate stopper 38. By "located proximate stopper 38," it is understood that at least a portion of flow restrictor 34 is positioned close enough to stopper 38 to prevent fluid from flowing through flexible tube 36. Accordingly, when flow restrictor 34 is in a first or resting position and spring 34b is in a corresponding biased position, an occluding portion 44 of locking member 34a may press flexible tube 36 against stopper 38 so as to occlude flexible tube 36 and prevent fluid flow therethrough. Cassette 30 may be in the first, or resting position prior to insertion of cassette 30 into pumping device 20, and after cassette 30 is removed from pumping device 20.

[0036] As previously discussed, as cassette 30 is inserted into pumping device 20, actuation member 22 contacts actuating portion 46 of locking member 34a. Upon continued

insertion into pumping device 20, actuation member 22 will continue to act upon actuating portion 46 of locking member 34a to rotate locking member 34a to a second, actuated position (not shown), thereby applying tension to spring 34b and moving occluding portion 44 of locking member 34a away from stopper 38 such that flow restrictor 34 is located away from stopper 38. By "located away from stopper 38," it is understood that flow restrictor 34 is positioned sufficiently far enough away from stopper 38 to allow fluid to flow through flexible tube 36. Accordingly, when flow restrictor 34 is in an actuated position, occluding portion 44 of locking member 34a does not occlude flexible tube 36 against stopper 38 and, therefore, allows fluid to flow therethrough.

[0037] When cassette 30 is fully inserted into pumping device 20, actuation member 22 remains in contact with actuating portion 46 of locking member 34a to allow fluid to flow through flexible tube 36 during the time that cassette 30 resides in pumping device 20. As cassette 30 is removed from pumping device 20, actuation member 22 loses contact with actuating portion 46 of locking member 34a allowing the tension on spring 34b to relax. As the tension on spring 34b relaxes, spring 34b and locking member 34a are allowed to return to the first, or resting, position. In an embodiment, the locking member 34a and spring 34b relax and rotate clockwise until actuating portion 46 of locking member 34a contacts stopper 38, which prevents further clockwise rotation of locking member 34b. Accordingly, when cassette 30 is removed from pumping device 20, flow restrictor 34 moves to the first, relaxed position, which occludes flexible tube 36.

[0038] As a result, flow restrictor 34 can be unlocked and deactivated by pumping device 20 when cassette 30 is inserted in pumping device 20 and reactivated when it is removed from pumping device 20. Unlike conventional anti-free flow devices in existing enteral feeding tube sets, cassette 30 is not deactivated by closing a door, by pressure, or a roller clamp. Instead, it will be deactivated by physically rotating flow restrictor 34 via a feature in pumping device 20.

[0039] In sum, the flow restriction mechanism of cassette 30 can be activated by a bias on spring 34b and deactivated via application of tension to spring 34b by rotating locking member 34a. The locking member 34a, which works in conjunction with the bias of spring 34b, will seal the flow path thereby preventing flow through flexible tube 36. This flow restriction mechanism prevents any static pressure loss during pumping. When cassette 30 is inside pumping device 20, the flow can be prevented/controlled by pump rollers (e.g., peristaltic pumps) within pumping device 20.

[0040] It should be understood that various changes and modifications to the presently preferred embodiments described herein will be apparent to those skilled in the art. Such changes and modifications can be made without departing from the spirit and scope of the present subject matter and without diminishing its intended advantages. It is therefore intended that such changes and modifications be covered by the appended claims.

CLAIMS

1. A cassette for being positioned within a pumping device comprising:
a housing comprising a flow restrictor comprising a locking member, a peg that is attached to the housing and a spring; and
a flexible tube comprising a first end attached to an inlet port and a second end attached to an outlet port of the housing, a flexible tube being positioned adjacent the flow restrictor and a stopper, the stopper being arranged on an opposite side of the tube from the flow restrictor, the locking member being constructed and arranged to rotate from a first resting position that restricts fluid flow through the tube to a second actuated position that allows fluid flow through the tube, wherein the locking member and the spring are arranged to rotate about a common axis of rotation that is shared with the peg.
2. The cassette of Claim 1, wherein the flow restrictor and the stopper occlude the tube when the flow restrictor is in the resting position.
3. The cassette of Claim 1, wherein the flow restrictor and the stopper allow a fluid to flow through the tube when the flow restrictor is in the actuated position.
4. A flow control system comprising:
a cassette according to any one of claims 1-3, and
a pumping device comprising an actuation member;
wherein the cassette is removably attached to the pumping device, and wherein the flow restrictor of the cassette is so constructed and arranged to align with the actuation member of the pumping device when the cassette is positioned within the pumping device.
5. The flow control system of Claim 4, wherein the alignment of the flow restrictor and the actuation member causes actuation of the flow restrictor.
6. The flow control system of Claim 4, wherein the actuation of the flow restrictor comprises rotation of the flow restrictor.
7. The flow control system of Claim 4, wherein the actuation member is a projection.
8. A method of controlling fluid flow in a tube, the method comprising:
providing a cassette comprising 1) a housing having a flow restrictor and a stopper, wherein the flow restrictor comprises a locking member, a spring and a peg that is attached to

the housing and 2) a flexible tube comprising a first end attached to an inlet port and a second end attached to an outlet port of the housing and positioned adjacent the flow restrictor and the stopper, the stopper being arranged on an opposite side of the tube from the flow restrictor;

occluding fluid flow through the tube by positioning an occluding portion of the flow restrictor at a location proximate the stopper; and

passing fluid through the tube by positioning the occluding portion of the flow restrictor at a location away from the stopper, wherein positioning of the occluding portion is obtained by rotation of said locking member about a common axis with said spring of the flow restrictor, wherein the common axis is shared with said peg.

9. The method of Claim 8, further comprising actuating the flow restrictor by contacting an actuating portion of the flow restrictor with an actuation member of a pumping device when the cassette is positioned within the pumping device.

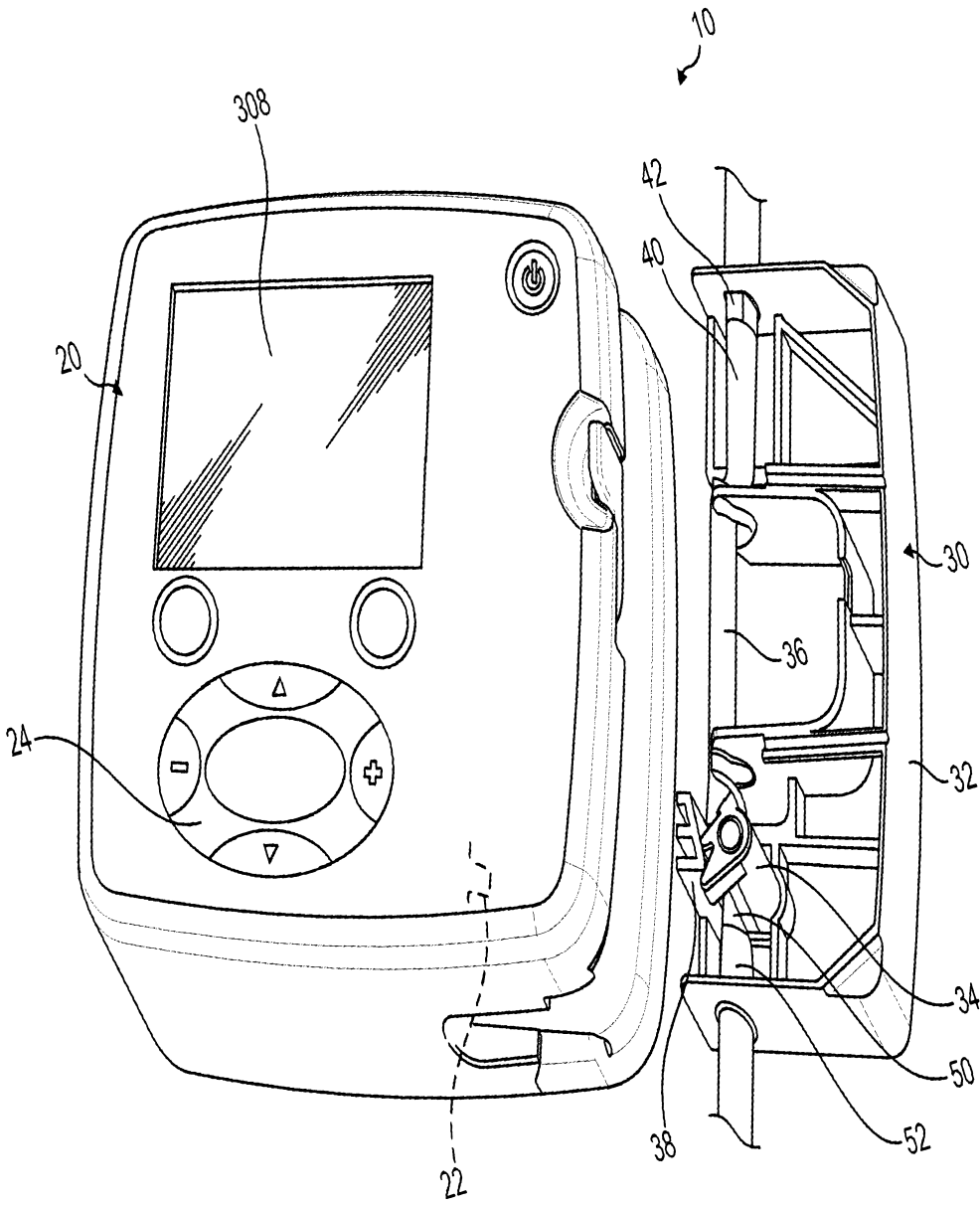

FIG. 1

2/4

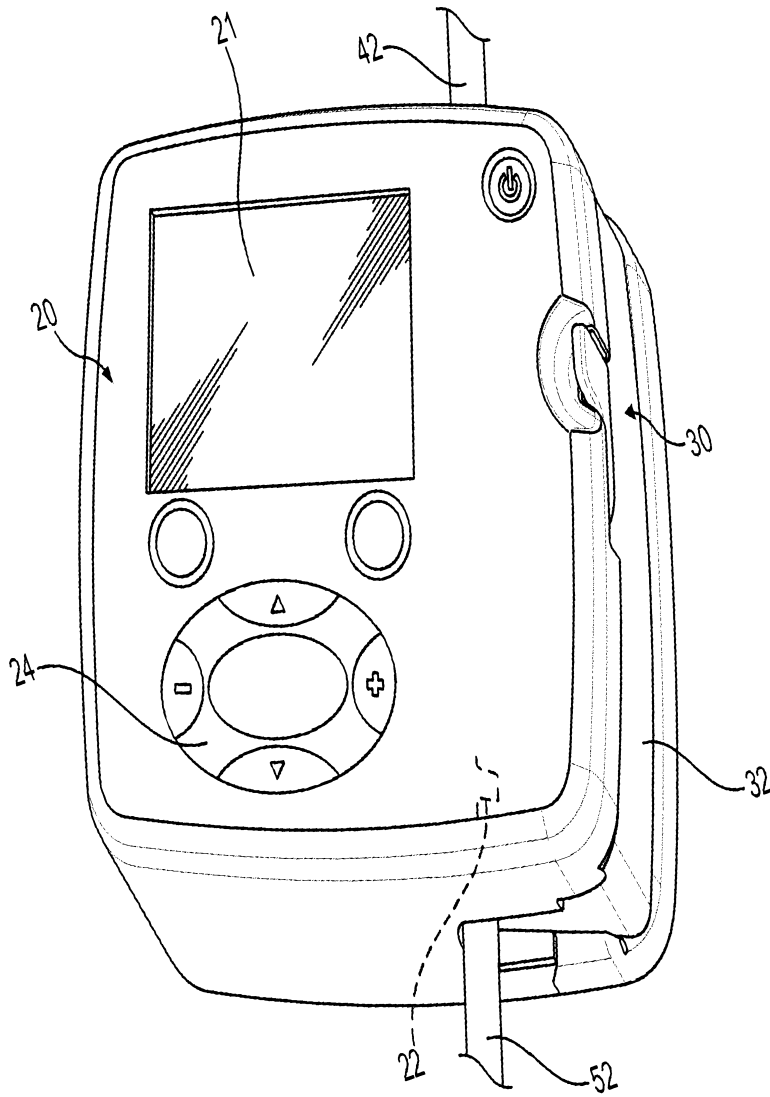

FIG. 2

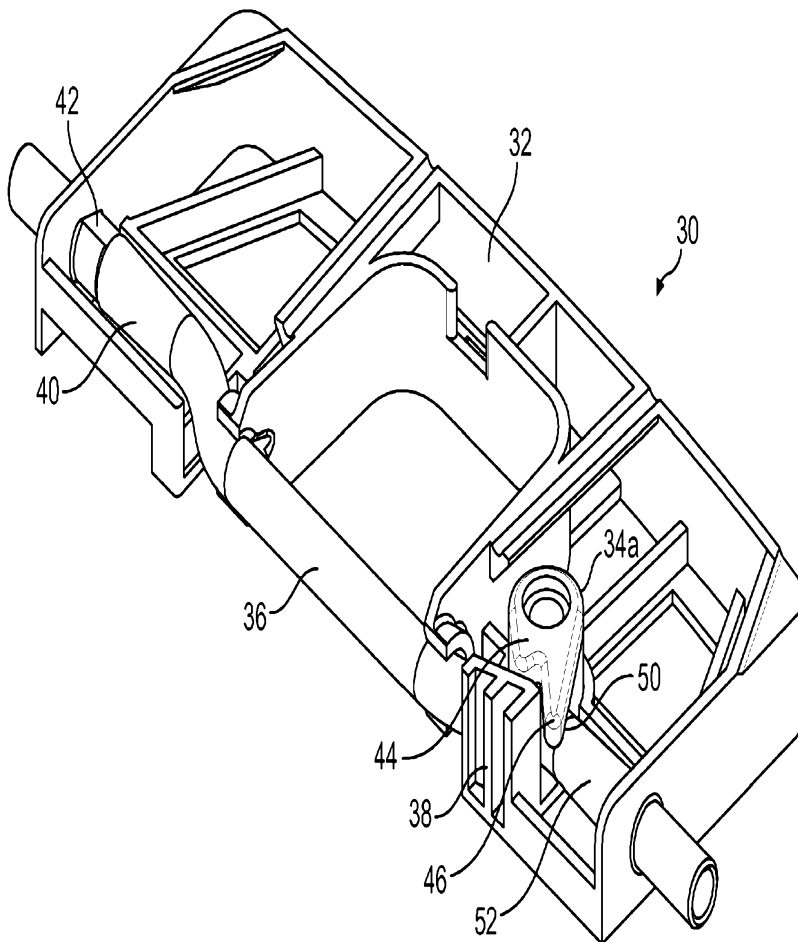

FIG. 3

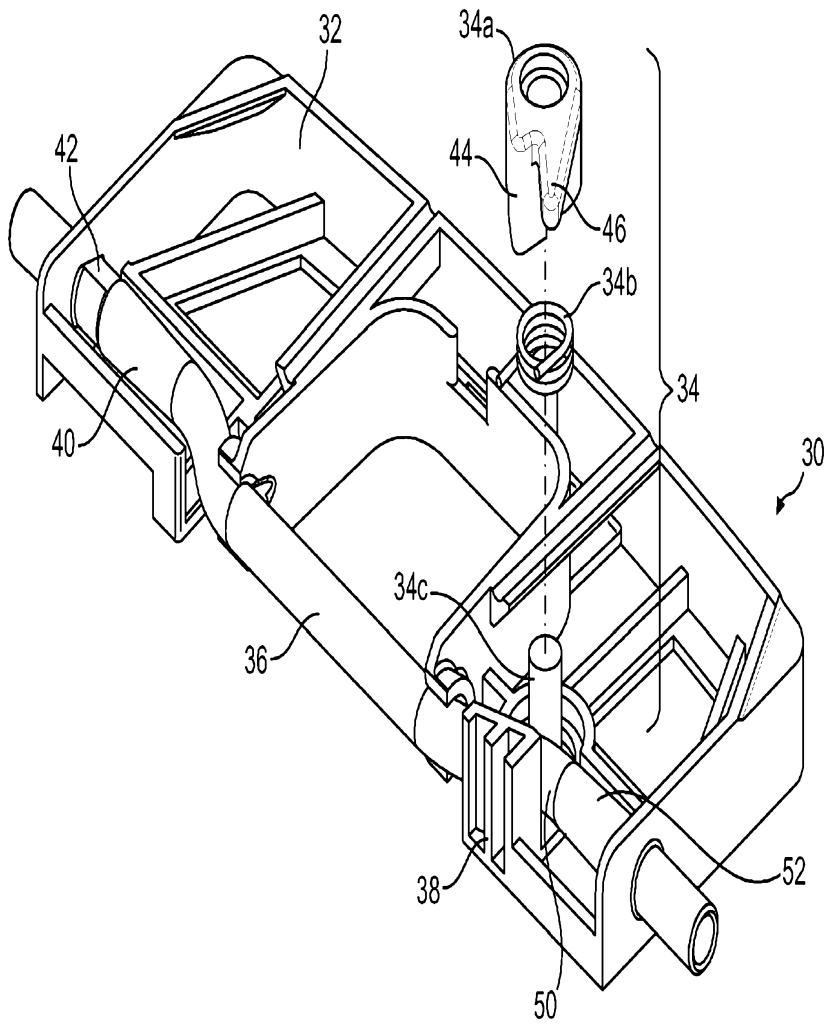

FIG. 4