

(19)



(11)

EP 3 845 698 B1

(12)

EUROPEAN PATENT SPECIFICATION

(45) Date of publication and mention of the grant of the patent:
27.12.2023 Bulletin 2023/52

(51) International Patent Classification (IPC):
D06F 37/06 ^(2006.01) **D06F 23/02** ^(2006.01)
D06F 39/08 ^(2006.01)

(21) Application number: **19855736.5**

(52) Cooperative Patent Classification (CPC):
D06F 37/06; D06F 23/025; D06F 39/083

(22) Date of filing: **16.08.2019**

(86) International application number:
PCT/CN2019/100998

(87) International publication number:
WO 2020/042922 (05.03.2020 Gazette 2020/10)

(54) TOP-OPEN TYPE WASHING MACHINE

VON OBEN ZU ÖFFNENDE WASCHMASCHINE
 LAVE-LINGE À CHARGEMENT PAR LE HAUT

(84) Designated Contracting States:
AL AT BE BG CH CY CZ DE DK EE ES FI FR GB GR HR HU IE IS IT LI LT LU LV MC MK MT NL NO PL PT RO RS SE SI SK SM TR

- **LAO, Chunfeng**
Qingdao, Shandong 266101 (CN)
- **XU, Sheng**
Qingdao, Shandong 266101 (CN)

(30) Priority: **27.08.2018 CN 201810981402**

(74) Representative: **Beck & Rössig**
European Patent Attorneys
Denninger Str. 169
81925 München (DE)

(43) Date of publication of application:
07.07.2021 Bulletin 2021/27

- (73) Proprietors:
- **Qingdao Haier Washing Machine Co., Ltd.**
Qingdao, Shandong 266101 (CN)
 - **Qingdao Haier Smart Technology R&D Co., Ltd.**
Qingdao, Shandong 266101 (CN)
 - **Haier Smart Home Co., Ltd.**
Qingdao, Shandong 266101 (CN)

- (56) References cited:
- | | |
|--------------------------|--------------------------|
| EP-A1- 2 557 215 | WO-A1-02/04734 |
| CN-A- 104 452 184 | CN-A- 107 523 969 |
| CN-A- 109 423 800 | CN-A- 109 423 801 |
| CN-A- 109 423 817 | CN-A- 109 423 853 |
| CN-A- 109 423 854 | CN-A- 110 195 306 |
| CN-A- 110 195 315 | CN-A- 110 195 331 |
| CN-A- 110 195 333 | CN-U- 205 856 868 |
| DE-A1- 3 820 409 | US-A- 4 971 449 |
| US-A- 5 115 651 | |

- (72) Inventors:
- **LI, Yimin**
Qingdao, Shandong 266101 (CN)
 - **LIU, Haitao**
Qingdao, Shandong 266101 (CN)

EP 3 845 698 B1

Note: Within nine months of the publication of the mention of the grant of the European patent in the European Patent Bulletin, any person may give notice to the European Patent Office of opposition to that patent, in accordance with the Implementing Regulations. Notice of opposition shall not be deemed to have been filed until the opposition fee has been paid. (Art. 99(1) European Patent Convention).

Description

[0001] The present invention relates to a top-loading washing machine comprising the features of the preamble portion of claim 1, and specifically relates to a top-loading washing machine which comprises a imperforate drum without dewatering holes and is provided with a clothes input port in the top portion.

[0002] Washing machines can be roughly divided into pulsator type washing machines, agitator type washing machines and drum washing machines. Generally, washing machines remove stains from laundries through the action of water and detergents.

[0003] A pulsator type washing machine performs washing operation by rotating a pulsator in the center of a washing tub in the left-right direction. The agitator type washing machine uses a friction force between water flow and laundries to perform washing operation by rotating fins in the center of the washing tub in the left-right direction. The drum washing machine performs washing operation by rotating a drum to beat the laundries.

[0004] A drum washing machine is generally provided with a housing internally provided with a tub used for accommodating washing water; a drum used for accommodating laundries is disposed on the inner side of the tub, and a motor and a shaft which are used for rotating the drum are disposed on the back surface of the tub.

[0005] In addition, there is a control part that controls a washing progress, and it is usually a control panel, and a water inlet and drainage mechanism, and the like. The drum washing machine uses a friction force between washing water stored in a water tub and laundries in a drum, and the chemical action of a detergent contained in the washing water to remove stains from the laundries.

[0006] As an important part of a washing machine, a washing drum is not only used to accommodate the laundries and constitute a washing container, but also participates in the washing work. Especially, the drum washing machine mainly lifts and throws the clothes to achieve a beating effect by means of the rotation action of the washing drum. At the same time, the washing drum also has a certain rubbing effect on the clothes, which relies on beating and washing to achieve a washing effect; and in addition to pulsator washing, most of the existing pulsator type washing machines also use a washing drum to wash clothes, such as a so-called "dual power" washing machine which is popular on the market.

[0007] Compared with the pulsator type washing machines, the disadvantages of the drum washing machines are that since a door is disposed on the front side, it is inconvenient to open the door to add clothes again after water enters the washing machine, and users must bend down or squat down to put in or take out the clothes, which is very inconvenient for the elderly or pregnant women. As a result, a top-loading drum washing machine has emerged, which combines the advantages, such as thorough washing and small wear, of a drum washing machine with the advantages, such as taking out and

putting in clothes from an upper opening and adding clothes in the middle of washing, of a pulsator type washing machine.

[0008] A top-loading washing machine comprising the features of the preamble portion of claim 1 is known from US 5,115,651 A. The drum is perforated so that washing water in an outer tub may reach the laundry within the drum.

[0009] A pulsator type washing machine is known from CN 107 523 969 A having valves that open under centrifugal force for dewatering.

[0010] The object of the present invention is to realize controllable sealing of a drain outlet of a top-opening drum washing machine of the type defined in the preamble portion of claim 1.

[0011] This technical problem is solved by a provide a top-loading washing machine comprising all features of claim 1.

[0012] Advantageous embodiments are indicated in further claims. Compared with the prior art, by the adoption of the above technical solution, the present disclosure has the following beneficial effects.

[0013] Through the above settings, the goal of discharging water flow in the drum from the hidden drainage ports is achieved by hiding the drainage ports inside the lifting ribs of the drum. Meanwhile, the sealing valves are disposed at the drainage ports to realize that the centrifugal force during the high-speed rotation of the drum is used to correspondingly control the valve cores of the sealing valves, so as to correspondingly open and close the drainage ports, thus achieving the goal that the drainage ports are automatically opened to correspondingly discharge water in the drum after the centrifugal force of the high-speed rotation of the drum acts on the valve cores of the sealing valves when the washing machine executes a dewatering procedure.

[0014] Furthermore, the foregoing valve plug structures are mounted on the drum, so that the balancing weights can be used to generate, under the action of the centrifugal force, the action of correspondingly opening the drainage ports, and the return springs can be also used to pull back the valve plug pillars and enable the valve cores to correspondingly block the drainage ports, thus achieving the goal of correspondingly opening and closing the drainage ports by means of the action of the centrifugal force of the high-speed rotation of the drum on the valve plug pillars.

[0015] Since the side wall of the drum of the washing machine is provided with the clothes input port capable of being correspondingly opened and closed by the door body, the goal that a user takes out and puts in clothes from the side wall of the drum is achieved, the overall structural layout of the drum washing machine is improved, and the user can observe the inside of the drum from top to bottom conveniently, and put in and take out the clothes conveniently. In addition, the drum is set as a imperforate drum without dewatering holes, so that the whole structure of the washing machine is simplified, and

two ends of the drum are respectively supported and fixed by the rotating shafts, thereby improving the steadiness of the rotation of the drum and lowering the noise and vibration of the washing machine in a running process.

[0016] Since the drum of the washing machine is set as a sealed container without dewatering holes, the drum simultaneously has dual effects of a water accommodating tub and an agitation drum, thereby avoiding the phenomenon, caused by flowing of the washing water between a drum and a tub, that stains remain on the outer wall of the drum and the inner wall of the tub, improving the cleanliness of the inside of the washing machine and achieving the goal of non-cleaning of the washing machine.

[0017] Meanwhile, the present disclosure is simple in structure, outstanding in effect and suitable for being popularized and used.

[0018] The specific implementation embodiments of the present disclosure are further described below in detail in combination with the accompanying drawings.

[0019] In the drawings:

Fig. 1 is a structural schematic diagram of a washing machine in the embodiments of the present disclosure;

Fig. 2 is a structural schematic diagram in which a door body of a washing machine is in a closed state in the embodiments of the present disclosure;

Fig. 3 is a structural schematic diagram in which a door body of a washing machine is in an open state in the embodiments of the present disclosure;

Fig. 4 is a structural schematic diagram in which a door body of a drum is in a closed state in the embodiments of the present disclosure;

Fig. 5 is a structural schematic diagram in which a door body of a drum is in an open state in the embodiments of the present disclosure;

Fig. 6 is a structural schematic diagram of a clothes input port of a drum of a washing machine in the embodiments of the present disclosure;

Fig. 7 is a structural schematic diagram of a section of a clothes input port of a drum in the embodiments of the present disclosure;

Fig. 8 is a structural schematic diagram of an axial section of a drum in the embodiments of the present disclosure; and

Fig. 9 and Fig. 10 are schematic diagrams of radial sections of a drum in different embodiments of the present disclosure.

[0020] In the drawings: 100: housing; 200: drum; 300: door body; 400: hinge structure; 500: locking structure; 700: door cover; 800: tub; O1: side wall; 02: sealing part; 03: clothes input port; 011: rotating shaft; 2: lifting rib; 3: mounting cavity; 4: drainage port; 5: valve plug pillar; 6: mounting sleeve; 7: balancing weight; 8: connection rib; 9: supporting plate; 10: supporting rib; 11: gap; 12: water permeation hole; 13: insertion slot; 14: second extending

rib; 15: first mounting rib; 16: second mounting rib; 17: bolt; 18: location pin; 19: bolt hole; 20: fixing rib; 21: clamping claw; 22: limiting rib; 23: through hole; 24: valve core; 25: insertion hole; 26: location slot; 27: flange; 28: internal peripheral flange; 29: mounting rib; 30: extending rib; 31: hinging hole; 32: return spring; 33: strip-shaped through hole; 2000: lifting rib body.

[0021] In order to make the objectives, technical solutions and advantages of the embodiments of the present disclosure clearer, the technical solutions in the embodiments will be described clearly and completely below in conjunction with the drawings in the embodiments of the present disclosure. The following embodiments are used to describe the present disclosure, but not intended to limit the scope of the present disclosure.

[0022] In the description of the present disclosure, it should be noted that orientations or positional relationships indicated by the terms "upper", "lower", "inside", "outside" and the like are orientations or positional relationships as shown in the drawings, and are only for the purpose of facilitating and simplifying the description of the present disclosure instead of indicating or implying that devices or elements indicated must have particular orientations, and be constructed and operated in the particular orientations, so that these terms are construed as limiting the present disclosure.

[0023] In the description of the present disclosure, it should be noted that unless otherwise explicitly defined and defined, the terms "installed" and "connected" are to be understood broadly, and may be, for example, fixedly connected, or detachably connected, or integrally connected, or mechanically connected, or electrically connected, or directly connected, or indirectly connected through an intermediate medium. Those of ordinary skill in the art can understand the specific meanings of the above terms in the present disclosure according to specific situations.

[0024] Referring to Fig. 1 to Fig. 10, the embodiment of the present disclosure provides a washing machine, comprising a drum 200 mounted in a housing 100 of the washing machine. The drum 200 comprises a side wall 01 defining a cylindrical structure; two ends of the cylindrical side wall 01 are respectively blocked and sealed by sealing parts 02; the side wall 01 of the drum 200 is provided with a clothes input port 03; an openable and closable door body 300 is disposed at the clothes input port 03, so that a user can take clothes from and put clothes into the drum from the clothes input port 3 in the side wall 01 of the drum.

[0025] By means of the foregoing settings, goals that the clothes input port is formed in the side wall of the drum of the washing machine, and that the clothes input port formed in the drum is correspondingly hermetically closed by the door body, or is opened for the user to take out and put in clothes are achieved. Meanwhile, the goal that the clothes input port is formed in the side wall of the drum, so that the user can open the door body from the upper portion of the washing machine to take the clothes

from and put the clothes into the drum is achieved; and more particularly, the clothes input port of the drum is sealed by the door body, so that the drum can be set as a sealed container, therefore, in the washing process of the drum, two ends of the drum can be supported by rotating shafts, thus avoiding the phenomenon of eccentric rotation of the drum.

Fig. 1 and Fig. 8 show a washing machine. A side wall 01 of a drum 200 is provided with a clothes input port 03, and an openable and closable door body 300 is disposed at the clothes input port 03. Since the side wall of the drum of the washing machine is provided with the clothes input port capable of being correspondingly opened and closed by the door body, the goal that a user takes out and puts in clothes from the side wall of the drum is achieved, the overall structural layout of the drum washing machine is improved, and the user can observe the inside of the drum from top to bottom conveniently, and put in and take out the clothes conveniently.

[0026] In the present embodiment, two ends of the cylindrical side wall 01 of the drum 200 are respectively sealed by sealing parts 02, so that the drum defines a sealed cylindrical cavity. The drum 200 can be a sealed container which does not have dewatering holes and is only provided with the clothes input port 03 in the side wall 01 of the drum, so that the drum in the present embodiment simultaneously has the dual effects of rotation for washing clothes by beating and hermetical accommodation of washing water, and the effect of combining a drum and a tub of the drum washing machine to form a unique drum is achieved.

[0027] In the present embodiment, in order to realize a water inlet function of the drum forming the sealed container, any existing water inlet structure can be used. For example, a rotating shaft 011 connected to the center of the drum 200 is set as a sleeve, and two ends of the sleeve are enabled to communicate with the water inlet structure of the washing machine and the inside of the drum respectively, so as to achieve the goal of feeding water into the drum via the sleeve. In order to realize dewatering and drainage functions of the drum forming the sealed container, any existing dewatering and drainage structure can be disposed on the drum 200. For example, the side wall 01 is provided with drainage ports, and centrifugal valves are correspondingly disposed at the drainage ports, so that valve cores of the centrifugal valves are opened under the action of a centrifugal force during high-speed rotation of the drum and are closed under their own braking force during low-speed rotation of the drum.

[0028] In the present embodiment, at least one of two ends, in the axial direction, of the drum 200 is mounted on a housing 100 through a rotating shaft 011, and is connected with a rotor of a driving motor, so that the drum 200 can be mounted in the housing 100 in a manner of being rotatable around the rotating shafts 011. Preferably, the rotating shaft 011 is coaxial with the axis of the drum 200. Further preferably, the two sealed ends of the

drum 200 are respectively connected with the housing 100 via the rotating shaft 011, thus, the two ends of the drum 200 are supported, so that it prevents the drum 200 from eccentrically rotating in a rotating working process, and the washing machine is no longer provided with a deviation rectification structure, such as a balancing ring, thereby simplifying the overall structure of the washing machine, improving the steadiness of the operation of the whole machine, and lowering the vibration and noise.

[0029] As shown in Fig. 1 and Fig. 8, the drum 200 is mounted in a housing 100. The axis of the drum 200 is horizontally or slantways disposed. The side wall of the drum 200 is provided with a clothes input port 03, and the drum 200 is provided with a door body 300 capable of being flipped to open and close the clothes input port 03.

[0030] In the present embodiment, the drum 200 comprises a cylindrical side wall 01. Two ends of the cylindrical side wall 01 are respectively sealed by sealing parts 02 on the corresponding sides, so that the drum 200 forms a cylindrical sealed container. The cylindrical side wall 01 is provided with an opening, and the opening forms the clothes input port 03. The door body 300 can be flipped outwards to be opened to correspondingly cover the opening. Preferably, the axis of the drum 200 extends horizontally, and the two sealed ends of the drum 200 are respectively hinged to the housing 100 of the washing machine via rotating shafts 011, so that the drum 200 can be mounted inside the housing 100 of the washing machine in a manner of being rotatable around the shafts.

[0031] In the present embodiment, one side of the door body 300 is hinged to the drum 200 via a hinge structure 400, so that the door body can be mounted on the drum 200 in a manner of being rotatable around the rotating shaft.

[0032] In the present embodiment, the middle portion of the door body 300 protrudes towards the inside of the drum 200 to form a protruding part extending into the drum 200 from the clothes input port 03. The protruding part protrudes into the drum relative to the inner wall of the drum 200, so that the protrusion part drives clothes in the drum 200 to rotate along with the drum 200 to generate lifting and beating motion, so as to wash the clothes and the protruding part has a function of a drum lifting rib.

In the present embodiment, the door body 300 is provided with at least one additive input part. The additive input parts communicate with the inside of the drum 200 respectively via automatic input structures, so as to feed additives accommodated in the additive input parts into the drum 200. Preferably, the protruding part disposed on the door body 300 is hollowed inside, and the hollow cavity is provided with one or more mutually independent additive input parts.

[0033] In the present embodiment, the periphery of the door body 300 is a smooth ring-like curved surface, and the ring-like curved surface is in corresponding fit contact

with the outer wall, at the outer edge of the clothes input port 03, of the drum 200. In the present embodiment, a circle of sealing ring made of an elastic material is disposed at the corresponding fit contact parts of the door body 300 and the drum 200, so as to correspondingly seal buckled contact parts of the door body 300 and the drum 200.

[0034] In the present embodiment, the top portion of the housing 100 of the washing machine is provided with a door cover 700 capable of being flipped upwards to be opened. The clothes input port 03 formed in the drum 200 and the door cover 700 correspondingly overlap in a vertical direction, so that a user can open and close the door body 300, at the clothes input port 03 of the drum, inside the housing 100 from the opened door cover 700. As shown in Fig. 1 and Fig. 8, a tub 800 is also disposed in the housing 100 of the washing machine. The upper and lower ends of the tub 800 are respectively connected with the upper portion and the lower portion of the housing of the washing machine via hanging springs 82 and supporting members 83, so that the tub 800 can be mounted inside the housing 100 in a manner of being capable of generating a vibration displacement. The drum 200 is coaxially sleeved by the tub 800. Two ends of the tub 800 are sealed, so as to form the tub 800 into a sealed container used for accommodating inflowing water of the washing machine.

[0035] In the present embodiment, the top portion of the side wall of the tub 800 is provided with an opening, and the opening is corresponding to the clothes input port 3 formed in the side wall 01 of the drum, so that after the drum 200 stops rotating, the user can open and close, from the opening formed in the top portion of the side wall of the tub, the door body 300 at the clothes input port 3, thereby putting in and taking out clothes.

In the present embodiment, the drum 200 sleeved by the tub 800 is provided with a plurality of drainage ports 4. Sealing valves which are driven by a centrifugal force generated by high-speed rotation of the drum to be opened and closed are disposed at the drainage ports, so as to enable the inside of the drum 200 to controllably communicate with a cavity between the drum 200 and the tub 800.

[0036] In the present embodiment, an openable and closable tub cover for correspondingly sealing the opening is correspondingly disposed at the opening formed in the top portion of the side wall of the tub 800, so that the tub forms an independent sealed container in a running process of the washing machine; or, as shown in Fig. 2 and Fig. 3, the top portion of the housing 100 of the washing machine is provided with a door cover 700. After the door cover 700 is buckled to the housing 100, the door cover 700 can correspondingly seal and close the opening formed in the tub 800, so that the goal of correspondingly sealing the opening in the tub of the washing machine can also be achieved.

[0037] In the present embodiment, in order to ensure the sealing of the tub and prevent the washing water ac-

commodated in the tub from flowing out from the opening, the following settings are further provided.

[0038] In the present embodiment, the opening of the tub 800 is connected with a flexible sleeve 81 extending upwards. The flexible sleeve 81 is composed of a corrugated pipe capable of generating axial and radial telescopic displacements. One end of the flexible sleeve 81 is hermetically connected with the inner wall of the opening formed in the tub 800, and the other end of the flexible sleeve 81 is hermetically connected with the inner wall of the corresponding opening formed in the housing 100, so that the opening of the tub 800 communicates with the corresponding opening in the housing 100 via the flexible sleeve 81, thereby avoiding the phenomenon that the washing water in the tub flows from the opening to a space between the tub and the housing.

[0039] At the same time, in order to improve the convenience of use of the washing machine, a drum locating device can be additionally disposed on the washing machine, so that when the drum stops rotating, a rotation stop position of the drum is always that the clothes input port formed in the drum faces the opening in the top portion of the housing, and the user can conveniently operate the door body at the clothes input port, and put clothes into the drum and take the clothes from the drum via the clothes input port.

Fig. 1 to Fig. 5 show a drum lifting rib structure for the foregoing cleaning-free washing machine. The drum lifting rib 2 comprises a lifting rib body 2000 extending along a generatrix of the side wall of the drum. The body is of a shell structure open at the lower side and buckled to the inner side wall of the drum 200. The inside of the lifting rib bodies 2000 is hollow to form a mounting cavity 3 for mounting the sealing valve. The lifting rib 2 is provided with a water passing structure for guiding washing water in the drum 200 into the corresponding mounting cavity 3.

[0040] Since each drum lifting rib is set to be provided with a hollow cavity to form, inside the lifting rib, a cavity for mounting a drainage sealing valve, hidden assembling of the sealing valves is achieved, and a function that the cleaning-free washing machine drains water by means of a centrifugal force is achieved. At the same time, the lifting ribs extend along the generatrix of the drum, so that when the drum rotates, the lifting ribs block the washing water flowing on the wall, and the blocked washing water flows into the lifting ribs via the water passing structures disposed on the lifting ribs to achieve the goal of guiding the water flow to be discharged.

[0041] As shown in Fig. 1, in the present embodiment, two opposite side walls of the lower side of each lifting rib body 2000 are respectively provided with mounting ribs which vertically protrude downwards. The lower ends of the mounting ribs are provided with mounting structures fixed to the side wall of the drum 200.

[0042] In the present embodiment, the left side edge and the right side edge of the lower side of each lifting rib 2 are provided with a first mounting rib 15 and a second

mounting rib 16 respectively. The lower end of each first mounting rib 15 is provided with a bolt hole 19 fixedly mounted relative to a bolt hole formed in the side wall of the drum 200, and the lower end of each second mounting rib 16 is provided with a location pin 18 which is correspondingly inserted in a location hole formed in the side wall of the drum 200 for location. Further preferably, two first mounting ribs 15 and two second mounting ribs 16 are distributed at four end corners of each square lifting rib 2, and furthermore, the two first mounting ribs 15 are symmetrically disposed relative to the center of the lifting rib 2, and the two second mounting ribs 16 are symmetrically disposed relative to the center of the lifting rib 2.

[0043] Since the four end corners of each lifting rib are respectively provided with the mounting ribs for fixation, so that the four end corners of the lifting rib are respectively mounted in a fastened manner, and further the lifting rib is assembled more firmly. At the same time, the bolt holes and the location pins are respectively disposed on the mounting ribs, so that the lifting ribs are pre-located and assembled by the location pins, and then are fastened and fixed by bolts, thus increasing the assembling rate of the lifting ribs.

[0044] As shown in Fig. 4, in the present embodiment, two opposite side walls of the lower side surface of the lifting rib 2 are each provided with a fixing rib 20 that vertically protrudes downwards. The lower ends of the fixing ribs 20 are provided with clamping claws 21 which horizontally protrude and extend, and the clamping claws 21 are enabled to be correspondingly clamped into clamping holes formed in the side wall of the drum 200 for fixation. Preferably, the fixing ribs 20 are close to the centers of the corresponding side edges of the lifting rib 2. Further preferably, the clamping claws 21 protrude and extend from the corresponding side edges of the lifting rib 2 towards the center of the lifting rib 2.

[0045] In the present embodiment, each lifting rib body 2000 is a taper which gradually protrudes upwards from the left and right sides to the middle portion.

[0046] As shown in Fig. 2 to Fig. 4, in the present embodiment, the periphery of the lifting rib 2 is a square having arc chamfers at the end corners. The left and right side surfaces of the lifting rib 2 are slopes which gradually rise from the periphery to the center. The top portion of the lifting rib 2 is a smooth arc surface which has an arc chamfer and connects the top portions of the two side surfaces. The front and rear ends of the lifting rib 2 are slopes which gradually tilt downwards from the end portions of the smooth arc surface to the periphery. Two side edges of the slopes are hermetically connected with the corresponding ends of the side surfaces of the lifting rib 2 via the arc chamfered surface.

[0047] The appearance surface of each lifting rib is set to be composed of a plurality of smooth curved surfaces to lower the friction between the lifting ribs and clothes, thus improving the washing efficiency and reducing the clothes washing wear rate.

[0048] In the present embodiment, the periphery of each lifting rib body 2000 is in corresponding fit contact with the side wall of the drum 200. Each periphery is provided with at least one segment of gap 11, so that the washing water in the drum 200 flows into the corresponding mounting cavity 3 from the gaps 11. Preferably, the left and right side edges of each square lifting rib 2 are respectively provided with a plurality of segments of gaps 11 disposed at intervals. Further preferably, the left and right side edges are each provided with one segment of gap 11 close to two ends. The first mounting ribs 15 and the second mounting ribs 16 are respectively disposed in corresponding sections together with the gaps 11 at the corresponding end corners. The fixing ribs 20 and the gaps are staggered.

[0049] The bottom portion of each lifting rib is provided with a plurality of segments of staggered gaps, so that on the premise of providing stable assembling for the lifting ribs, the washing water flowing on the wall of the drum is caused to flow into the lifting ribs via the gaps after being blocked by the lifting ribs, and then the goal of discharging, under the action of the centrifugal force of the high-speed rotation of the drum, all the washing water via the gaps in the bottom portion of the lifting ribs.

[0050] In the present embodiment, the lower side of each mounting cavity 3 defined by the corresponding lifting rib 2 is composed of the side wall of the drum 200. Corresponding regions of the side wall of the drum 200 are provided with drainage ports 4 communicating with the insides of the mounting cavities 3. Sealing valves controlled to be opened and closed by means of the centrifugal force are mounted at the drainage ports 4. Preferably, the drainage ports 4 are disposed on the axis of each lifting rib 2.

[0051] In the present embodiment, the lower side of each lifting rib 2 is provided with two limiting ribs 22 which vertically extend downwards and are located in the corresponding mounting cavity. A certain clearance is reserved between the two limiting ribs 22 of each lifting rib 2. Balancing weights of the sealing valves are enabled to move in the clearance, so that the clearance provides a limiting effect for the motion of the sealing valves. Preferably, the two limiting ribs 22 of each lifting rib 2 are symmetrically arranged relative to the axis of the lifting rib 2.

[0052] As shown in Fig. 3, in the present embodiment, a plurality of water permeation holes 12 are formed in the lifting rib body 2000. The water permeation holes 12 enable the mounting cavity 3 to communicate with the drum outside the lifting rib body 2000, so as to guide the washing water in the drum 200 into the lifting rib to further increase the rate that the washing water in the drum flows into the lifting rib. Preferably, the rear end of the lifting rib 2 is close to a drum bottom, and a certain clearance is reserved between the bottom portion of the rear side of the lifting rib 2 and the side wall of the drum 200, so as to guide the washing water in the mounting cavity 3 to flow backwards to the drum bottom of the drum 200.

Fig. 1 to Fig. 7 show a sealing valve mounting structure for the foregoing washing machine. The sealing valve mounting structure comprises a supporting plate 9 mounted on the inner side wall of the drum 200; a middle portion of the supporting plate 9 is provided with a through hole 23 corresponding to the drainage port 4 formed in the side wall of the drum 200. A clearance is reserved between the supporting plate 9 and the side wall of the drum 200, so as to form space for allowing the valve core of sealing valve to move up and down. A sleeve-shaped mounting sleeve 6 is fixedly mounted on the upper side of each supporting plate 9; an inner side through hole of the mounting sleeve 6 is coaxially arranged to the through hole 23 formed in the supporting plate 9, so as to mount the valve core of the sealing valve in the inner side through hole coaxially in a manner of being movable up and down.

[0053] Since the foregoing mounting structure is disposed on the drum, the valve core of the sealing valve disposed at the drainage port can be correspondingly assembled in the clearance between the supporting plate and the drum, thus achieving the goal that the valve core has up-and-down movement at the clearance to ensure that the valve core correspondingly block or open the drainage port. At the same time, valve plug pillar is correspondingly assembled in the mounting sleeve, and then is limited in a motion direction by the mounting sleeve, thereby avoiding a tilting phenomenon of the valve plug pillar. Furthermore, the mounting sleeve is disposed on the supporting plate, so that balancing weight supporting point of the sealing valve is correspondingly mounted at the periphery of the mounting sleeve, and prying rotation and mounting fixation of balancing weight is guaranteed.

[0054] In the present embodiment, the sealing valve mounting structure is disposed inside the lifting rib in the foregoing embodiment I, so that one or more sealing valves can be mounted in the mounting cavity inside the lifting rib; and each sealing valve comprises one sealing valve mounting structure.

[0055] As shown in Fig. 1, in the present embodiment, the side wall of the drum 200 of the washing machine is provided with at least one lifting rib 2. Each lifting rib body 2000 is of a shell structure open at the lower side and buckled to the inner side wall of the drum 200. The lifting rib body 2000 is hollow inside to form the mounting cavity 3 for mounting the sealing valve, and the sealing valve mounting structure is disposed in the mounting cavity 3.

[0056] As shown in Fig. 5 to Fig. 7, in the present embodiment, the supporting plate 9 is a plate laid on the inner side wall of the drum. The lower side of the supporting plate 9 is provided with a plurality of segments of supporting ribs 10 protruding and extending downwards. The lower end of the supporting rib 10 is in limiting contact with the inner side wall of the drum 200. Preferably, the periphery of the supporting plate 9 is provided with a plurality of segments of supporting ribs 10 disposed at intervals. Further preferably, the left and right sides of the

supporting plate 9 are provided with a plurality of segments of supporting ribs 10 disposed at intervals, and the front and rear sides of the supporting plate 9 are provided with a supporting rib 10 extending along the corresponding side edge.

[0057] In the present embodiment, the left and right sides of the lifting rib 2 are respectively provided with gaps 11, and the gaps 11 correspond to the side portions of the supporting plates 9, so as to enable the side portions of the supporting plates 9 to be clamped in the gaps 11 on the corresponding sides.

[0058] In the present embodiment, the supporting plate 9 is provided with a downwards sunken location slot 26 and a penetrating insertion hole 25. The insertion hole 25 vertically penetrates through the corresponding supporting plate. The lower side of each lifting rib 2 is provided with the first mounting rib 15 which protrudes and extends downwards and coaxially corresponds to the insertion hole 25. The lower end of the first mounting rib 15 is provided with bolt hole 19 coaxially opposite to the insertion hole. The bolt 17 upward passes through the drum wall and the supporting plate 9 in sequence from the outer wall of the drum 200, and then is correspondingly screwed and fixed to the bolt hole 19 formed in the first mounting rib 15, so that the supporting plate 9 and the lifting rib 2 are both fixed and mounted to the drum 200. The location slot 26 is formed in the upper side surface of the supporting plate 9, and the lower side of the lifting rib 2 is provided with the second mounting rib 16 which protrudes and extends downwards and coaxially corresponds to the location slot 26. The lower end of the second mounting rib 16 is provided with the location pin 18 correspondingly inserted in the location slot 26 for limitation.

[0059] In the present embodiment, the mounting sleeve 6 is of a vertically extending cylindrical structure. The mounting sleeve 6 is open at the lower end and provided with a flange 27 horizontally protruding inwards at the upper end. The internal periphery of the flange 27 is provided with an internal peripheral flange 28 which vertically extends downwards to the lower end of the corresponding mounting sleeve 6. The clearance is reserved between the outer wall of the internal peripheral flange 28 and the inner wall of the flange 27, so as to define the cavity for mounting and fixing the return spring of the sealing valve. Preferably, the lower end of the mounting sleeve 6 is attached to and placed on the upper side of the corresponding supporting plate 9. The mounting sleeve 6 is coaxial with the through hole 23 formed in the corresponding supporting plate 9. The cross-section diameter of the inner side of the lower end of the mounting sleeve 6 is less than or equal to the diameter of the corresponding through hole 23, and the cross-section diameter of the outer side of the lower end of the mounting sleeve is greater than the diameter of the corresponding through hole 23.

[0060] In the present embodiment, the upper side of each supporting plate 9 is provided with a mounting rib

29 protruding and extending upwards. The upper end of the mounting sleeve 6 is provided with an extending rib 30 horizontally protruding and extending outwards. The extending end of the extending rib 30 and the upper end of the corresponding mounting rib 29 are in corresponding overlapping fit, and the overlapping part is fixedly connected via a bolt, so that the supporting plate 9 and the corresponding mounting sleeve 6 are fastened and mounted via the bolt. Preferably, the upper side of the supporting plate 9 is provided with one mounting rib 29 at each of the left and right sides of the corresponding through hole 23. The left and right sides of each mounting sleeve 6 are each provided with an extending rib 30 horizontally protruding and extending outwards, so that the two extending ribs 30 and the mounting ribs 29 on the corresponding sides correspondingly overlap and are fixed and mounted via bolts.

[0061] In the present embodiment, one side of the mounting sleeve 6 is provided with a second extending rib 14 horizontally protruding and extending outwards. The extending end of the second extending rib 14 is provided with a hinging hole 31 with a horizontal axis, so as to hinge and mount the balancing weight of the sealing valve. Preferably, an included angle between the extending direction of the second extending rib 14 and the extending direction of the corresponding extending rib 30 is 90 degrees, and the axis of the hinging hole 31 is parallel to the extending direction of the corresponding extending rib 30. Further preferably, the extending end of the second extending rib 14 is higher than the top portion of the corresponding mounting sleeve 6. The extending end of each second extending rib 14 is provided with an insertion slot 13. The insertion slot 13 is disposed in the extending direction of the second extending rib 14, so as to allow the balancing weight of the sealing valve to be correspondingly inserted therein. The insertion slot 13 is provided with a hinging hole 31 which extends horizontally.

[0062] In the present embodiment, two sealing valve mounting structures are disposed in the mounting cavity 3 defined by the inside of each lifting rib 2, and the second extending ribs 14 of the two sealing valve mounting structures oppositely extend in the direction close to each other.

Fig. 1 to Fig. 7 disclose a valve plug structure of sealing valve for the foregoing washing machine. The valve plug structure of the sealing valve comprises a valve plug pillar 5 correspondingly mounted at the drainage port formed in the side wall of the drum 200, and balancing weight 7 hinged to the upper end of the valve plug pillar 5. Sealing valve mounting structure is fixedly mounted on the side wall of the drum 200. The return spring 32 is clamped between the sealing valve mounting structure and the valve plug pillar 5.

[0063] The foregoing valve plug structure is mounted on the drum, so that the balancing weight can be used to generate, under the action of the centrifugal force, action of correspondingly opening the drainage port, and

the return spring can be also used to pull back the valve plug pillar and enable the valve core to correspondingly block the drainage port, thus achieving the goal of correspondingly opening and closing the drainage port by means of the action of the centrifugal force generated by the high-speed rotation of the drum on the valve plug pillar.

[0064] The valve plug structure of the sealing valve in the present embodiment can be mounted on the sealing valve mounting structure in the foregoing embodiment II, and can also be fixedly mounted on the drum of the washing machine via the foregoing sealing valve mounting structure. Particularly, the valve plug structure of the sealing valve in the present embodiment can also be correspondingly mounted in the lifting rib of the embodiment I via the sealing valve mounting structure of the embodiment II. Since the mounting structure extending towards the hollow portion of the lifting rib is disposed on the side wall of the drum, a supporting rod is mounted at the top portion of a mounting seat at a certain height away from the side wall of the drum to enable the end portion of the supporting rod and the side wall of the drum to have a certain height difference, which achieves the goal that the balancing weight moves downwards and drop to provide a displacement space for prying the valve core.

[0065] As shown in Fig. 5 to Fig. 7, in the present embodiment, the valve plug pillar 5 is coaxially disposed at the drainage port 4. The lower end of the valve plug pillar 5 is provided with the valve core 24 which radially protrude outwards. Preferably, the valve core 24 is a plug with the radial size being gradually increased outwards from bottom to top. The radial width of the large-head end of the valve core 24 is greater than the diameter of the corresponding drainage port 4, and the radial width of the small-head end of each valve core 24 is less than the diameter of the corresponding drainage port 4.

[0066] In the present embodiment, the sealing valve mounting structure comprises a supporting plate 9 mounted on the inner side wall of the drum 200; a middle portion of the supporting plate 9 is provided with a through hole 23 corresponding to the drainage port 4 formed in the side wall of the drum 200. The certain clearance is reserved between the supporting plate 9 and the side wall of the drum 200, so as to form a space for allowing the valve core of the sealing valve to move up and down. A sleeve-shaped mounting sleeve 6 is fixedly mounted on the upper side of each supporting plate 9; an inner side through hole of the mounting sleeve 6 is coaxially opposite to the through hole 23 formed in the supporting plate 9, so as to mount the valve plug pillar 5 of the sealing valve in the inner side through hole coaxially in a manner of being movable up and down.

[0067] In the present embodiment, the mounting sleeve 6 is of a vertically extending cylindrical structure. The mounting sleeve 6 is open at the lower end and provided with a flange 27 horizontally protruding inwards at the upper end. The internal periphery of the flange 27 is provided with an internal peripheral flange 28 which ver-

tically extends downwards to the lower end of the corresponding mounting sleeve. The certain clearance is reserved between the outer wall of the internal peripheral flanges 28 and the inner wall of the flange 27, so as to define the cavity for allowing mounting and fixing the return spring 32 of the sealing valve. Preferably, the return spring 32 sleeves the outer wall of the corresponding internal peripheral flange 28; the upper end of each return spring 32 abuts against the lower side of the corresponding flange 27, and the lower end of the return spring 32 abuts against the large-head end of the corresponding valve core 24. Further preferably, the outer wall of the valve plug pillar 5 is in limiting abutting against the inner wall of the corresponding internal peripheral flange 28.

[0068] In the present embodiment, one side of the mounting sleeve 6 is provided with a second extending rib 14 horizontally protruding and extending outwards. The extending end of each second extending rib 14 is provided with a hinging hole 31 with a horizontal axis. The balancing weight 7 of the sealing valve and the second extending ribs 14 are hinged and mounted via the insertion pin passing through the hinging hole 31.

[0069] In the present embodiment, the upper end of the balancing weight 7 is provided with a connection rib 8 which protrudes and extends upwards in the axial direction. The upper end of the valve plug pillar 5 penetrates out of the top portion of the corresponding mounting sleeve 6. The end portion of each connection rib 8 is hinged to the upper end of the corresponding valve plug pillar 5. The middle portion of each connection rib 8 overlaps and is inserted into the second extending rib 14 of the corresponding mounting sleeve 6, and the connection rib 8 and the corresponding second extending rib 14 are hinged and mounted at the overlapping part via the penetrating insertion pin. Preferably, the extending end of each second extending rib 14 is higher than the top portion of the corresponding mounting sleeve 6, and is provided with an insertion slot 13 disposed in the extending direction of the second extending rib 14. The middle portion of the connection rib 8 of the sealing valve is correspondingly inserted into the corresponding insertion slot 13. The insertion slot 13 is provided with a hinging hole 31 which extends horizontally, and the middle portion of the connection rib 8 is provided with a hinging hole correspondingly overlapping with the hinging hole 31, so that the connection rib 8 and the corresponding second extending rib 14 are hinged and mounted at the overlapping part via the penetrating insertion pin.

[0070] In the present embodiment, the end portion of each connection rib 8 is provided with a rotating hole hinged to the upper end of the corresponding valve plug pillar 5. The rotating hole is a strip-shaped type through hole 33 extending in the axial direction of each connection rib 8, so that when the balancing weight 7 rotates around the mounting sleeve 6, space allowance is provided for the connection ribs 8 driving the valve plug pillar 5 to move up and down.

[0071] In the present embodiment, the peripheral di-

ameter of the upper end of the valve core 24 is greater than the diameter of the lower end of the corresponding internal peripheral flange, and the height of each valve core 24 is less than the height of the clearance between the corresponding supporting plate and the side wall of the drum.

In the present embodiment, two sealing valves are correspondingly disposed in the mounting cavity 3 defined by the inside of the lifting rib 2, and the two sealing valves are arranged along the generatrix of the drum. The balancing weights 7 of the valve core structures of the two sealing valves oppositely extend in the direction close to each other.

[0072] In the present embodiment, when the washing machine is in a dewatering and/or drainage state, the drum is in a high-speed rotation state, and water in the drum flows along the inner wall under the action of the centrifugal force and flows into the lifting ribs from the gaps between the wall of the drum and the lifting ribs. At this time, the balancing weights move towards the periphery of the drum under the action of the centrifugal force, and provide an upward prying force that is towards the center direction of the drum to the valve plug pillars through the connection ribs. The centrifugal force of the balancing weights on the valve cores counteracts the elastic force of the return springs, so that the valve plug pillars generate displacement in the radial direction of the drum and open the drainage ports. When the washing machine is in a non-dewatering state and a non-drainage state, the drum is not in the high-speed rotation state, and the balancing weights are no longer stressed by the centrifugal force. The return springs are in a pulled state, and apply a pushing force that is towards the peripheral direction of the drum to the valve plug pillars, so that the valve cores move towards the initial position until the drainage ports are closed. In addition, when the drum is in a washing or rinsing procedure, the return springs keep providing an elastic force to the valve plug pillars to ensure that the valve cores block the drainage ports all the time, and then ensure that the drainage ports are in the closed states all the time.

Based on the washing machine according to any one of the foregoing embodiments, the washing machine further may have the following technical features: the inner side wall 01 of the drum 200 is provided with a plurality of lifting ribs 2 symmetrically arranged relative to the axis of the drum. The side wall 01 of the drum is provided with drainage ports 4 opposite to the lifting ribs 2. Sealing valves corresponding to the drainage ports 4 are respectively disposed inside the lifting ribs 2.

[0073] As shown in Fig. 10, in the present embodiment, the plurality of lifting ribs 2 disposed on the drum 200 are symmetrically arranged at equally-spaced angles, so that clothes in the drum 200 can be subjected to the actions of the uniformly arranged lifting ribs 2 and be lifted and beaten at a constant speed, thus improving the clothes washing efficiency.

[0074] As shown in Fig. 9, in the present embodiment,

the plurality of lifting ribs 2 disposed on the drum 200 can also be set as follows: the lifting ribs 2 are arranged in a manner of corresponding to the door body 03 of the drum, so that the gravity center of the drum 200 is located at the central axis, thereby guaranteeing the balance of the drum in a rotating process and improving the rotating steadiness of the drum.

Based on the washing machine according to any one of the foregoing embodiments, the washing machine further may have the following technical features: the drainage ports 4 formed in the drum 200 are located on the same section, and the side wall 01 of the drum is gradually increased in drum diameter from two ends to the section on which the drainage ports 4 are located. The side wall of the drum is set as a tapered drum which gradually protrudes outwards from two ends to the direction of the drainage ports, so that the washing water in the drum flows on the wall under the action of the centrifugal force when the drum rotates at a high speed, and flows in a converged manner to the drainage ports, thereby guaranteeing the smoothness of drainage of the washing machine.

[0075] Although the present disclosure is disclosed above by the preferred embodiments, the preferred embodiments are not intended to limit the present disclosure. Any person skilled in the art can make some changes by using the above-mentioned technical contents without departing from the scope of the claims.

Claims

1. A top-loading washing machine, comprising

a housing (100),
 a drum (200) with two ends enclosed being mounted in the housing (100);
 a door body (300) openable and closable being disposed on a side wall of the drum (200); **characterized in that** the top-loading washing machine further comprises
 a drainage port (4) formed in the side wall (01) of the drum (200);
 a sealing valve mounted at the drainage port (4);
 a valve core (24) of the sealing valve is subjected to centrifugal force to open the drainage port (4) when the drum (200) rotates at a high speed, and seals the drainage port (4) when the drum (200) rotates at a low speed or is stationary;
 the sealing valve comprises a valve plug pillar (5) correspondingly mounted at the drainage port (4) formed in the side wall (01) of the drum (200), and a balancing weight (7) hinged to an upper end of the valve plug pillar (5); a sealing valve mounting structure is fixedly mounted on the side wall (01) of the drum (200); and a return spring (32) is clamped between the sealing valve mounting structure and the valve plug pillar (5);

the sealing valve mounting structure comprises a supporting plate (9) mounted on an inner side wall (01) of the drum (200); a middle portion of the supporting plate (9) is provided with a through hole (23) corresponding to the drainage port (4) formed in the side wall (01) of the drum (200); a clearance is reserved between the supporting plate (9) and the side wall (01) of the drum (200) to form a space for the valve core (24) of the sealing valve moving up and down; a mounting sleeve (6) is fixedly mounted on an upper side of the supporting plate (9); an inner side through hole of the mounting sleeve (6) is coaxially provided correspondingly to the through hole (23) formed in the supporting plate (9), so as to mount the valve plug pillar (4) of the sealing valve in the inner side through hole coaxially in a manner of being movable up and down.

2. The top-loading washing machine according to claim 1, **characterized in that** a lifting rib body (2000) extending along a generatrix of the side wall (01) of the drum (200) is disposed on the drum (200); the lifting rib body (2000) is of a shell structure and buckled to the inner side wall (01) of the drum (200), a lower side of the lifting rib body (2000) is open; the lifting rib body (2000) is hollow inside to form a mounting cavity (3); a lifting rib (2) is provided with a water passing structure for guiding washing water in the drum (200) into the mounting cavity (3); the drainage port (4) formed in the side wall (01) of the drum (200) is communicated with an inside of the mounting cavity (3); and the sealing valve is disposed in the mounting cavity (3).
3. The top-loading washing machine according to claim 2, **characterized in that** a plurality of lifting ribs (2) symmetrically arranged relative to an axis of the drum (200) are disposed on the inner side wall (01) of the drum (200); the lifting ribs (2) are symmetrically arranged at equally-spaced angles; or, the lifting ribs (2) are arranged in a manner of corresponding to the door body (100) of the drum (200), a gravity center of the drum (200) is located at the axis of the drum (200).
4. The top-loading washing machine according to claim 2 or 3, **characterized in that** a plurality of drainage ports (4) formed in the side wall (01) of the drum (200) are located on a same cross section, and a drum (200) diameter of the side wall (01) of the drum (200) is gradually increased from the two ends of the drum (200) to the cross section on which the drainage ports (4) are located.
5. The top-loading washing machine according to claim 4, **characterized in that** the mounting cavity (3)

formed in the lifting rib (2) is internally provided with two sealing valves correspondingly arranged, and balancing weights (7) of valve core structures of the two sealing valves oppositely extend in a direction close to each other.

6. The top-loading washing machine according to any one of claims 1 to 5, **characterized in that** the drum (200) is mounted in the housing (100) of the washing machine; at least one of the two ends of the drum (200) is mounted on the housing (100) through a rotating shaft (011) in an axial direction, and is connected with a rotor of a driving motor, and the drum (200) is mounted in the housing (100) in a manner of being rotatable around the rotating shaft (011).
7. The top-loading washing machine according to claim 6, **characterized in that** the drum (200) is sleeved inside a water accommodating part; a top portion of the water accommodating part is provided with an opening; the opening and a clothes input port (03) formed on the drum (200) are correspondingly disposed in a same vertical section, a user opens and closes the clothes input port (03) through the opening, and holds a handle part to drive the drum (200) to rotate.
8. The top-loading washing machine according to claim 7, **characterized in that** the water accommodating part is a tub (800) arranged coaxially with the drum (200), and the drum (200) is provided with the drainage port (4) communicated with the tub (800); or, the water accommodating part is a groove at least covering a lower half portion of the drum (200) and is opened at an upper portion.
9. The top-loading washing machine according to claim 7 or 8, **characterized in that** the opening of the water accommodating part is provided with a sealing door cover (700) independently; or, the housing (100) of the washing machine is provided with a door cover (700) capable of being flipped outwards to be opened, and the door cover (700) encloses the opening in the water accommodating part after the door cover (700) is closed.
10. The top-loading washing machine according to claim 9, **characterized in that** a flexible sleeve is disposed between the water accommodating part and the housing (100); one end of the flexible sleeve is hermetically connected with the opening of the water accommodating part, and another end of the flexible sleeve is hermetically connected with an opening formed correspondingly in the housing (100), and the water accommodating part is communicated with an outside through the flexible sleeve; and the door cover (700) disposed on the housing (100) covers the opening formed in the housing (100) in an open-

able and closable manner.

Patentansprüche

1. Toplader-Waschmaschine, umfassend

ein Gehäuse (100),
eine Trommel (200) mit zwei geschlossenen Enden, die in dem Gehäuse (100) montiert ist; einen Türkörper (300), der geöffnet und geschlossen werden kann und an einer Seitenwand der Trommel (200) angeordnet ist; **dadurch gekennzeichnet, dass** die Toplader-Waschmaschine ferner umfasst:

eine Abflussöffnung (4), die in der Seitenwand (01) der Trommel (200) ausgebildet ist;

ein Dichtungsventil, das an der Abflussöffnung (4) angebracht ist; wobei ein Ventileinsatz (24) des Dichtungsventils einer Zentrifugalkraft ausgesetzt ist, um die Abflussöffnung (4) zu öffnen, wenn sich die Trommel (200) mit einer hohen Geschwindigkeit dreht, und die Abflussöffnung (4) abdichtet, wenn sich die Trommel (200) mit einer niedrigen Geschwindigkeit dreht oder stillsteht; wobei das Dichtungsventil eine Ventilstopfensäule (5), die entsprechend an der in der Seitenwand (01) des Fasses (200) ausgebildeten Abflussöffnung (4) angebracht ist, und ein Auswuchtgewicht (7) umfasst, das an einem oberen Ende der Ventilstopfensäule (5) angelenkt ist; eine Dichtungsventil-Montagestruktur fest an der Seitenwand (01) der Trommel (200) montiert ist; und eine Rückstellfeder (32) zwischen der Dichtungsventil-Montagestruktur und der Ventilstopfensäule (5) eingeklemmt ist;

die Dichtungsventil-Montagestruktur eine Trägerplatte (9) umfasst, die an einer inneren Seitenwand (01) der Trommel (200) montiert ist; ein mittlerer Abschnitt der Trägerplatte (9) mit einem Durchgangsloch (23) versehen ist, das der in der Seitenwand (01) der Trommel (200) ausgebildeten Abflussöffnung (4) entspricht; ein Spielraum zwischen der Trägerplatte (9) und der Seitenwand (01) der Trommel (200) reserviert ist, um einen Raum für den Ventileinsatz (24) des Dichtungsventils zu bilden, der sich auf und ab bewegt; eine Montagehülse (6) fest auf einer Oberseite der Trägerplatte (9) montiert ist; ein innenseitiges Durchgangsloch der Montagehülse (6) koaxial entsprechend dem in der Trägerplatte (9) ausgebildeten Durchgangsloch (23) vorgesehen ist,

- um die Ventilstopfsäule (4) des Dichtungsventils in dem innenseitigen Durchgangsloch koaxial auf- und abbewegbar zu montieren.
2. Toplader-Waschmaschine nach Anspruch 1, **dadurch gekennzeichnet, dass** ein Heberippenkörper (2000), der sich entlang einer Mantellinie der Seitenwand (01) der Trommel (200) erstreckt, an der Trommel (200) angeordnet ist; der Heberippenkörper (2000) eine Schalenstruktur aufweist und an die innere Seitenwand (01) der Trommel (200) gebogen ist, wobei eine Unterseite des Heberippenkörpers (2000) offen ist; der Heberippenkörper (2000) innen hohl ist, um einen Montagehohlraum (3) zu bilden; eine Heberippe (2) mit einer Wasserdurchlassstruktur versehen ist, um Washwasser in der Trommel (200) in den Montagehohlraum (3) zu leiten; die in der Seitenwand (01) der Trommel (200) ausgebildete Abflussöffnung (4) mit einer Innenseite des Montagehohlraums (3) in Verbindung steht; und das Dichtungsventil in dem Montagehohlraum (3) angeordnet ist.
 3. Toplader-Waschmaschine nach Anspruch 2, **dadurch gekennzeichnet, dass** an der inneren Seitenwand (01) der Trommel (200) eine Vielzahl von symmetrisch zu einer Achse der Trommel (200) angeordneten Heberippen (2) angeordnet sind; die Heberippen (2) in gleichmäßig beabstandeten Winkeln symmetrisch angeordnet sind; oder, die Heberippen (2) so angeordnet sind, dass sie dem Türkörper (100) der Trommel (200) entsprechen, ein Schwerpunkt der Trommel (200) in der Achse der Trommel (200) liegt.
 4. Toplader-Waschmaschine nach Anspruch 2 oder 3, **dadurch gekennzeichnet, dass** eine Vielzahl von in der Seitenwand (01) der Trommel (200) ausgebildeten Abflussöffnungen (4) auf einem gleichen Querschnitt angeordnet sind, und ein Durchmesser der Trommel (200) der Seitenwand (01) der Trommel (200) von den beiden Enden der Trommel (200) zu dem Querschnitt, auf dem die Abflussöffnungen (4) angeordnet sind, allmählich zunimmt.
 5. Toplader-Waschmaschine nach Anspruch 4, **dadurch gekennzeichnet, dass** der in der Heberippe (2) ausgebildete Montagehohlraum (3) innen mit zwei entsprechend angeordneten Dichtungsventilen versehen ist und sich Auswuchtgewichte (7) von Ventileinsatzkonstruktionen der beiden Dichtungsventile entgegengesetzt in einer Richtung nahe beieinander erstrecken.
 6. Toplader-Waschmaschine nach einem der Ansprüche 1 bis 5, **dadurch gekennzeichnet, dass** die Trommel (200) in dem Gehäuse (100) der Wasch-
- maschine montiert ist; mindestens eines der beiden Enden der Trommel (200) über eine Drehwelle (011) in einer axialen Richtung an dem Gehäuse (100) montiert ist und mit einem Rotor eines Antriebsmotors verbunden ist, und die Trommel (200) in dem Gehäuse (100) so angebracht ist, dass sie um die Drehwelle (011) drehbar ist.
7. Toplader-Waschmaschine nach Anspruch 6, **dadurch gekennzeichnet, dass** die Trommel (200) in einen Wasseraufnahmeteil eingeschoben ist; ein oberer Abschnitt des Wasseraufnahmeteils mit einer Öffnung versehen ist; die Öffnung und eine an der Trommel (200) ausgebildete Wäscheeingabeöffnung (03) entsprechend in demselben vertikalen Abschnitt angeordnet sind, ein Benutzer die Wäscheingabeöffnung (03) durch die Öffnung öffnet und schließt und einen Griffteil hält, um die Trommel (200) zum Drehen anzutreiben.
 8. Toplader-Waschmaschine nach Anspruch 7, **dadurch gekennzeichnet, dass** der Wasseraufnahmeteil eine Wanne (800) ist, die koaxial zu der Trommel (200) angeordnet ist, und dass die Trommel (200) mit der Abflussöffnung (4) versehen ist, die mit der Wanne (800) in Verbindung steht; oder dass der Wasseraufnahmeteil eine Nut ist, die zumindest einen unteren Halbabschnitt der Trommel (200) bedeckt und an einem oberen Abschnitt geöffnet ist.
 9. Toplader-Waschmaschine nach Anspruch 7 oder 8, **dadurch gekennzeichnet, dass** die Öffnung des Wasseraufnahmeteils unabhängig mit einer abdichtenden Türabdeckung (700) versehen ist; oder das Gehäuse (100) der Waschmaschine mit einer Türabdeckung (700) versehen ist, die zum Öffnen nach außen geklappt werden kann, und die Türabdeckung (700) die Öffnung im Wasseraufnahmeteil verschließt, nachdem die Türabdeckung (700) geschlossen ist.
 10. Toplader-Waschmaschine nach Anspruch 9, **dadurch gekennzeichnet, dass** eine biegsame Hülse zwischen dem Wasseraufnahmeteil und dem Gehäuse (100) angeordnet ist; ein Ende der biegsamen Hülse hermetisch mit der Öffnung des Wasseraufnahmeteils verbunden ist und ein anderes Ende der biegsamen Hülse hermetisch mit einer Öffnung verbunden ist, die entsprechend in dem Gehäuse (100) ausgebildet ist, und der Wasseraufnahmeteil durch die biegsame Hülse mit der Außenseite in Verbindung steht; und die Türabdeckung (700), die an dem Gehäuse (100) angeordnet ist, die in dem Gehäuse (100) ausgebildete Öffnung in einer offenen und verschließbaren Weise abdeckt.

Revendications

1. Un lave-linge à chargement par le haut, comprenant

un corps (100),
 un tambour (200) avec deux extrémités fermées
 étant monté dans le corps (100);
 un corps de porte (300) pouvant être ouvert et
 fermé est disposé sur une paroi latérale
 du tambour (200);
caractérisé en ce que le lave-linge à charge-
 ment par le haut comprend en outre
 un orifice d'évacuation (4) formé dans la paroi
 latérale (01) du tambour (200);
 une soupape d'étanchéité montée au niveau de
 l'orifice d'évacuation (4); un noyau de soupape
 (24) de la soupape d'étanchéité est soumis à
 une force centrifuge de manière à permettre
 l'ouverture de l'orifice d'évacuation (4) lorsque
 le tambour (200) tourne à une vitesse élevée,
 et scelle l'orifice d'évacuation (4) lorsque le tam-
 bour (200) tourne à faible vitesse ou est au res-
 pos;
 la soupape d'étanchéité comprend une colonne
 de bouchon de soupape (5) montée de façon
 correspondante au niveau de la orifice d'éva-
 cuation (4) formé dans la paroi latérale (01) du
 tambour (200), et un poids d'équilibrage (7) ar-
 ticulé à une extrémité supérieure de la colonne
 de bouchon de soupape (5); une structure de
 montage de soupape d'étanchéité est montée
 fixement sur la paroi latérale (01) du tambour
 (200); et un ressort de rappel (32) est serré entre
 la structure de montage de soupape d'étanchéi-
 té et la colonne de bouchon de soupape (5);
 la structure de montage de soupape d'étanchéi-
 té comprend une plaque de support (9) montée
 sur une paroi latérale intérieure (01) du tambour
 (200); une partie centrale de la plaque de sup-
 port (9) est pourvue d'un trou traversant (23) cor-
 respondant à l'orifice d'évacuation (4) formé
 dans la paroi latérale (01) du tambour (200); un
 dégagement est réservé entre la plaque de sup-
 port (9) et la paroi latérale (01) du tambour (200)
 formant un espace pour le noyau de soupape
 (24) de la soupape d'étanchéité lui permettant
 de se déplacer vers le haut et vers le bas; un
 manchon de montage (6) est monté fixement
 sur un côté supérieur de la plaque de support
 (9); un trou traversant de côté intérieur du man-
 chon de montage (6) correspondant est disposé
 coaxialement par rapport au trou traversant (23)
 formé dans la plaque de support (9), de manière
 à permettre le montage de la colonne de bou-
 chon de soupape (4) de la soupape d'étanchéité
 dans le trou traversant de côté intérieur coaxia-
 lement de façon à lui permettre d'être déplaça-
 ble vers le haut ou vers le bas.

2. Le lave-linge à chargement par le haut selon la re-
 vendication 1, **caractérisé en ce qu'**un corps de ner-
 vure de levage (2000) s'étendant le long d'une gé-
 nératrice de la paroi latérale (01) du tambour (200)
 est disposé sur le tambour (200); le corps de nervure
 de levage (2000) ayant une structure de coque et
 étant bouclé à la paroi latérale intérieure (01) du tam-
 bour (200), un coté inférieur du corps de nervure de
 levage (2000) est ouvert; le corps de nervure de le-
 vage (2000) est creux à l'intérieur pour former une
 cavité de montage (3); une nervure de levage (2) est
 pourvue d'une structure laissant passer l'eau pour
 permettre le guidage de l'eau de lavage du tambour
 (200) vers la cavité de montage (3); l'orifice d'éva-
 cuation (4) formé dans la paroi latérale (01) du tam-
 bour (200) communique avec une partie intérieure
 de la cavité de montage (3); et la soupape d'étan-
 chéité est disposée dans la cavité de montage (3).
3. Le lave-linge à chargement par le haut selon la re-
 vendication 2, **caractérisé en ce qu'**une pluralité de
 nervures de levage (2) disposées symétriquement
 par rapport à un axe du tambour (200) sont dispo-
 sées sur la paroi latérale intérieure (01) du tambour
 (200); les nervures de levage (2) sont disposées sy-
 métriquement à des angles régulièrement espacés;
 ou
 les nervures de levage (2) sont disposées de ma-
 nière à correspondre au corps de porte (100) du tam-
 bour (200), un centre de gravité du tambour (200)
 est situé au niveau de l'axe du tambour (200).
4. Le lave-linge à chargement par le haut selon la re-
 vendication 2 ou 3, **caractérisé en ce qu'**une plu-
 ralité d'orifices d'évacuation (4) formés dans la paroi
 latérale (01) du tambour (200) sont situés sur une
 même section transversale, et un diamètre du tam-
 bour (200) de la paroi latérale (01) du tambour (200)
 est progressivement augmenté à partir des deux ex-
 trémités du tambour (200) jusqu'à la section trans-
 versale sur laquelle les orifices d'évacuation (4) sont
 situés.
5. Le lave-linge à chargement par le haut selon la re-
 vendication 4, **caractérisé en ce que** la cavité de
 montage (3) formée dans la nervure de levage (2)
 est pourvue intérieurement de deux soupapes
 d'étanchéité disposées de manière correspondante,
 et des poids d'équilibrage (7) des structures du
 noyau de soupape des deux soupapes d'étanchéité
 s'étendent d'une manière opposée dans une direc-
 tion proche l'une de l'autre.
6. Le lave-linge à chargement par le haut selon l'une
 quelconque des revendications 1 à 5, **caractérisé
 en ce que** le tambour (200) est monté dans le corps
 (100) du lave-linge; au moins une des deux extrémi-
 tés du tambour (200) est montée sur le corps (100)

par un arbre rotatif (011) dans une direction axiale, et est reliée à un rotor d'un moteur d'entraînement, et le tambour (200) est monté dans le corps (100) de manière à pouvoir tourner autour de l'arbre rotatif (011).

5

7. Le lave-linge à chargement par le haut selon la revendication 6, **caractérisé en ce que** le tambour (200) est emboîté à l'intérieur d'une partie pouvant accueillir l'eau; une partie supérieure de la partie pouvant accueillir l'eau est pourvue d'une ouverture ; l'ouverture et un port de placement de vêtements (03) formés sur le tambour (200) sont disposés en conséquence au niveau d'une même section verticale, un utilisateur ouvre et ferme le port de placement de vêtements (03) par l'intermédiaire de l'ouverture, et maintient une partie de poignée pour entraîner la rotation du tambour (200).
- 10
- 15
8. Le lave-linge à chargement par le haut selon la revendication 7, **caractérisé en ce que** la partie pouvant accueillir l'eau est une cuve (800) disposée coaxialement par rapport au tambour (200), et le tambour (200) est pourvu de l'orifice d'évacuation (4) communiquant avec la cuve (800); ou, la partie pouvant accueillir l'eau est une rainure couvrant au moins une demi-partie inférieure du tambour (200) et est ouverte au niveau d'une partie supérieure.
- 20
- 25
9. Le lave-linge à chargement par le haut selon la revendication 7 ou 8, **caractérisé en ce que** l'ouverture de la partie pouvant accueillir l'eau est indépendamment pourvue d'un couvercle de porte étanche (700); ou, le corps (100) du lave-linge est pourvu d'un couvercle de porte (700) pouvant être retourné vers l'extérieur pour être ouvert, et le couvercle de porte (700) englobe l'ouverture dans la partie pouvant accueillir l'eau après la fermeture du couvercle de porte (700).
- 30
- 35
- 40
10. Le lave-linge à chargement par le haut selon la revendication 9, **caractérisé en ce qu'**un manchon flexible est disposé entre la partie pouvant accueillir l'eau et le corps (100); une extrémité du manchon flexible est hermétiquement reliée à l'ouverture de la partie pouvant accueillir l'eau, et une autre extrémité du manchon flexible est hermétiquement reliée à une ouverture formée en conséquence dans le corps (100), et la partie pouvant accueillir l'eau communique avec une partie extérieure à travers le manchon flexible; et le couvercle de porte (700) disposé sur le corps (100) couvre l'ouverture formée dans le corps (100) de manière à permettre l'ouverture et la fermeture.
- 45
- 50
- 55

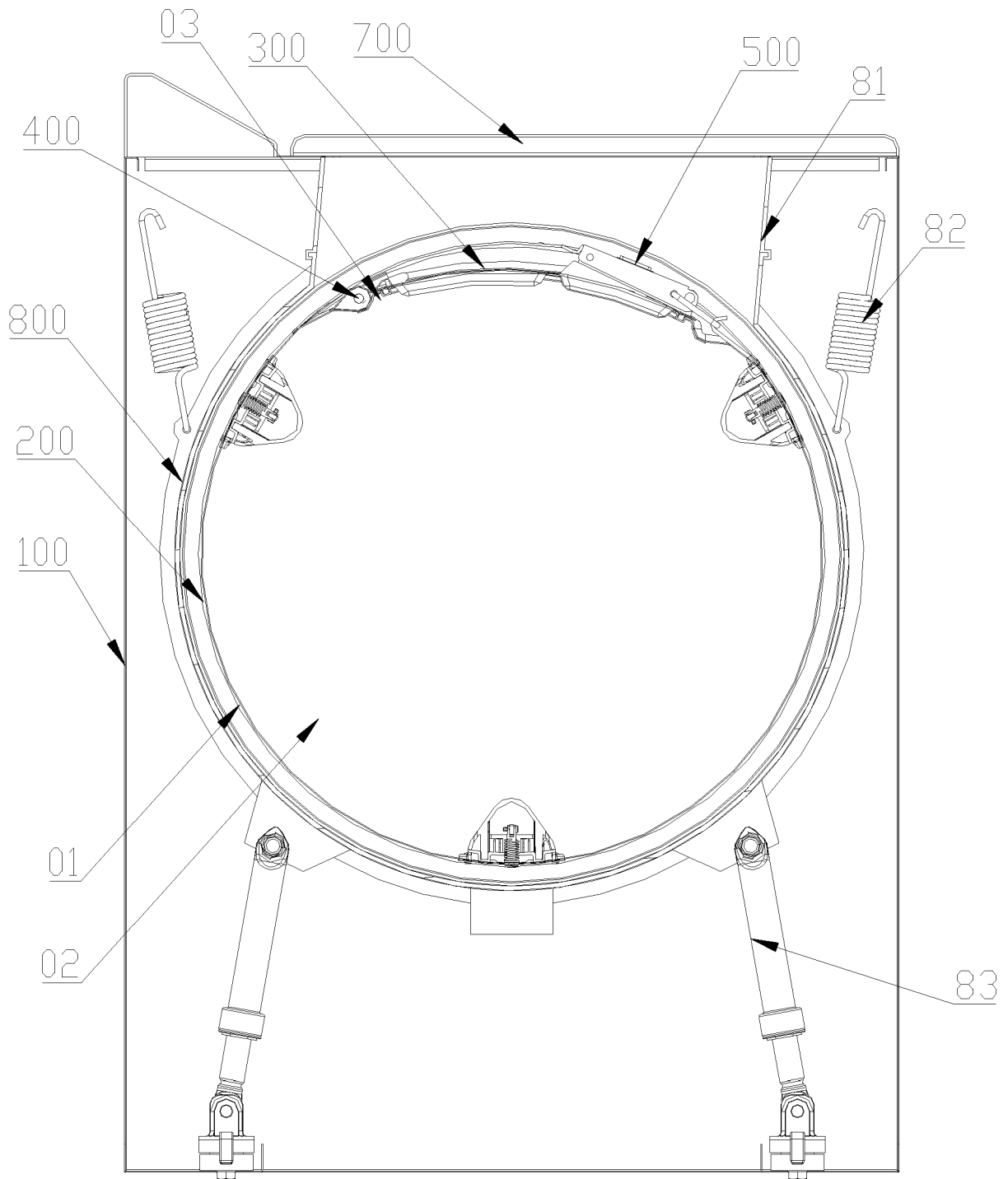

Fig. 1

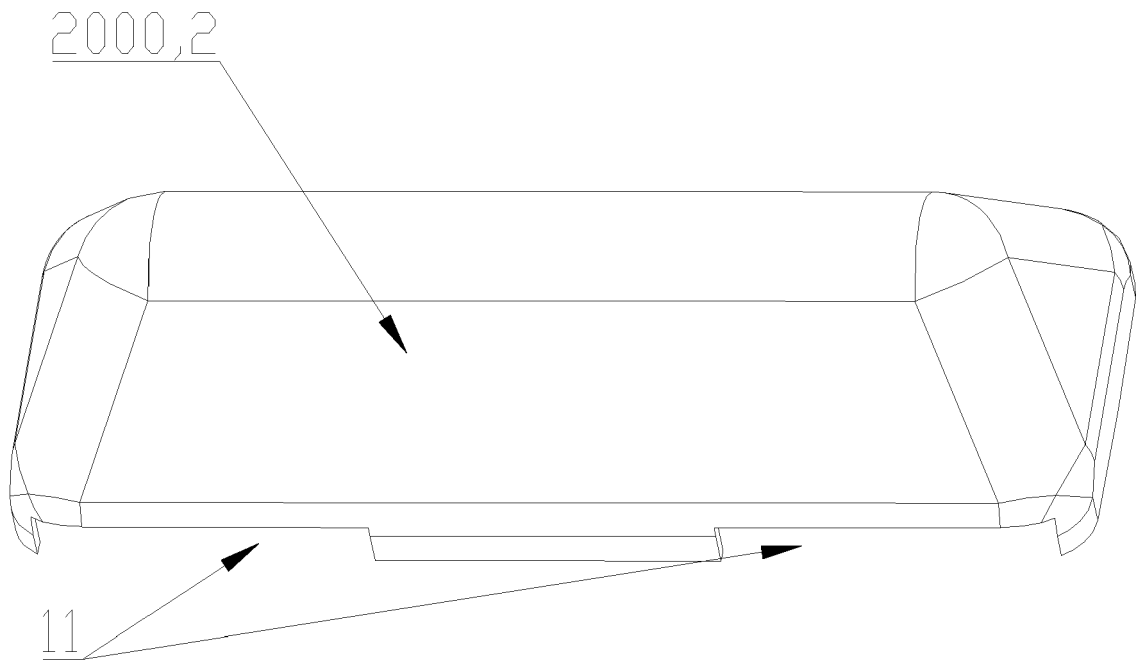

Fig. 2

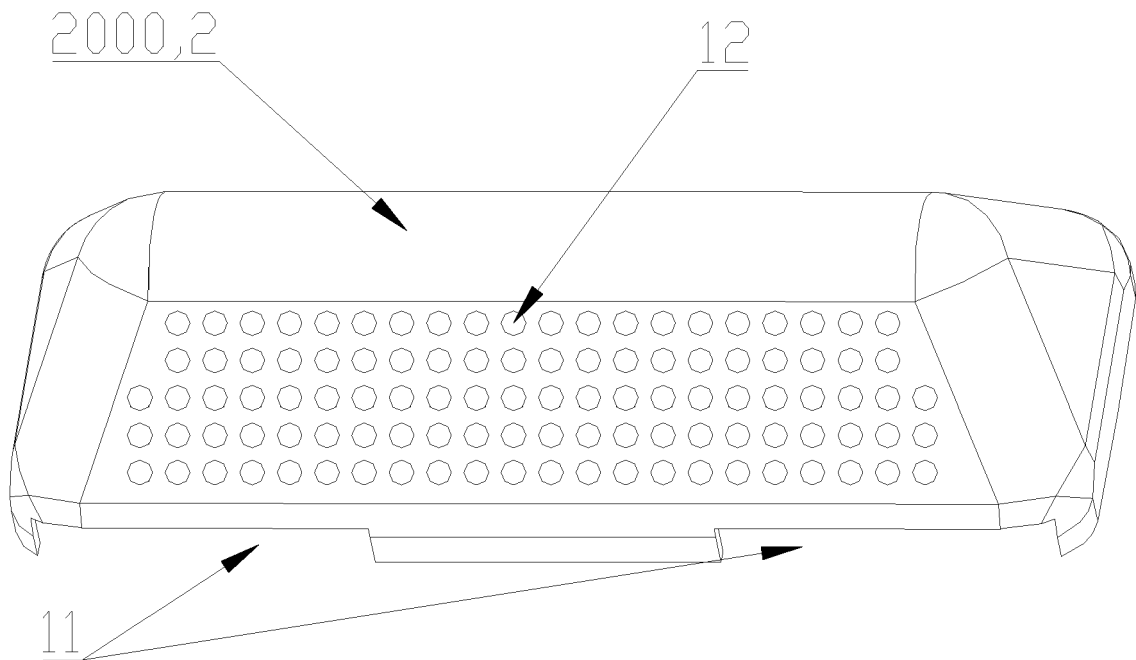

Fig. 3

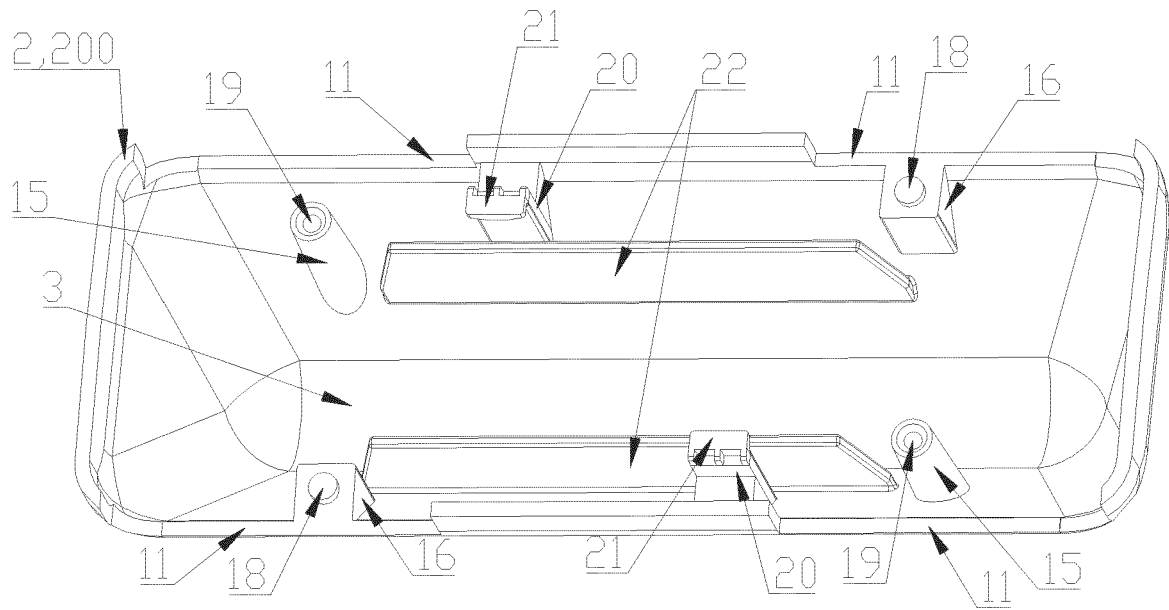

Fig. 4

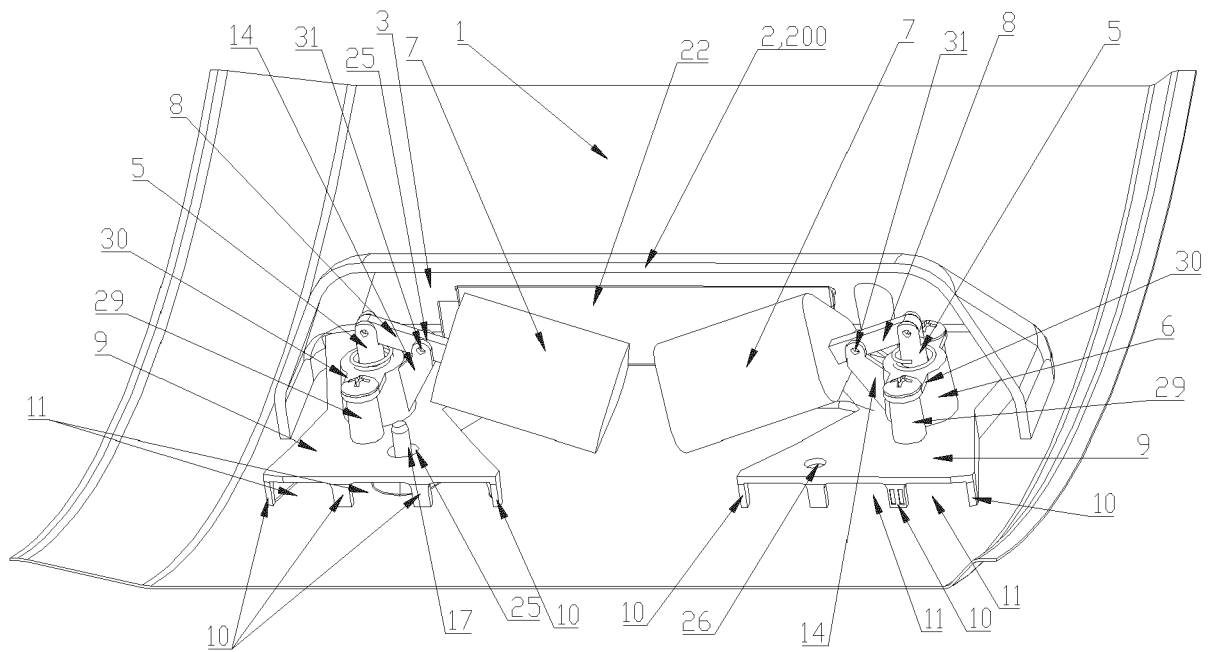

Fig. 5

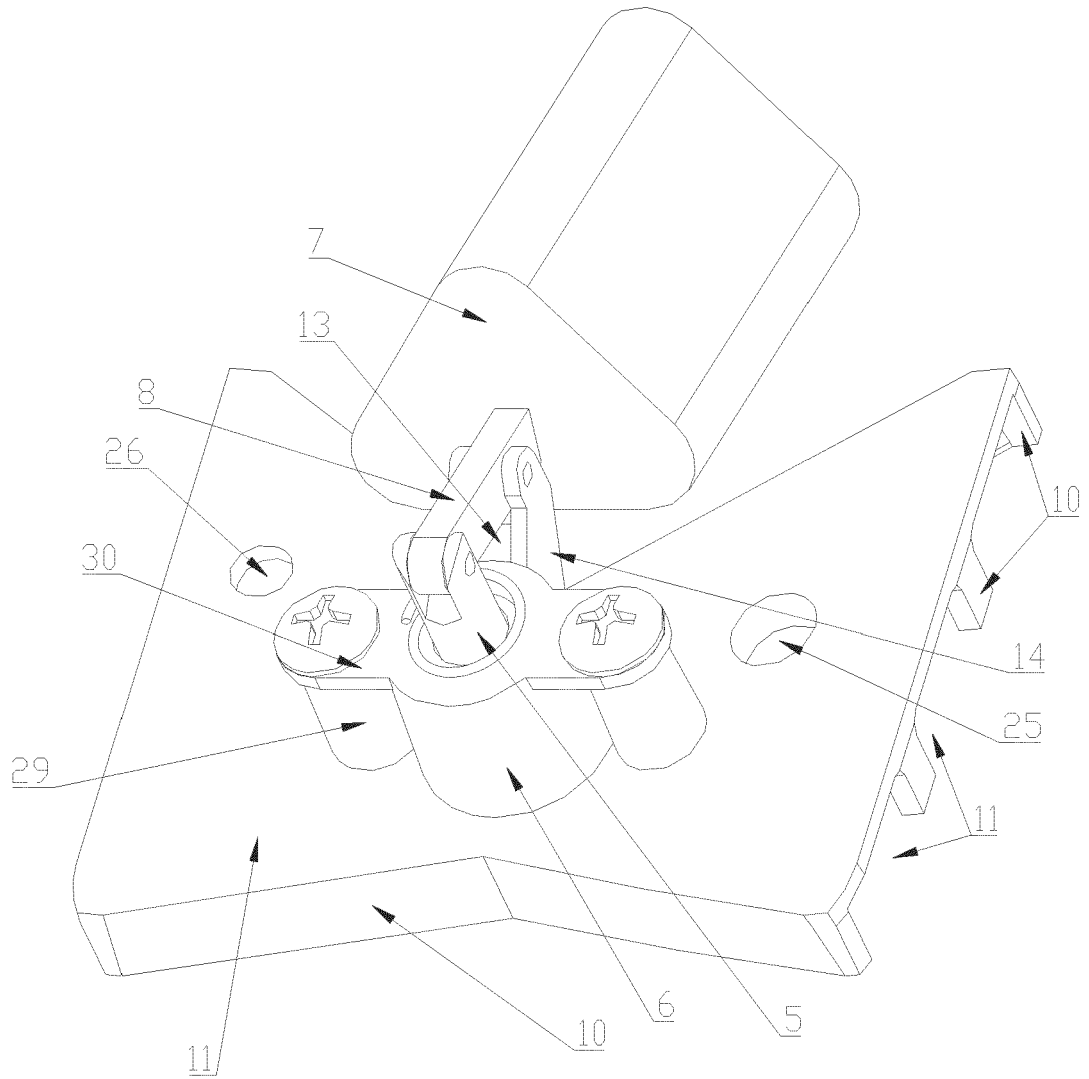

Fig. 6

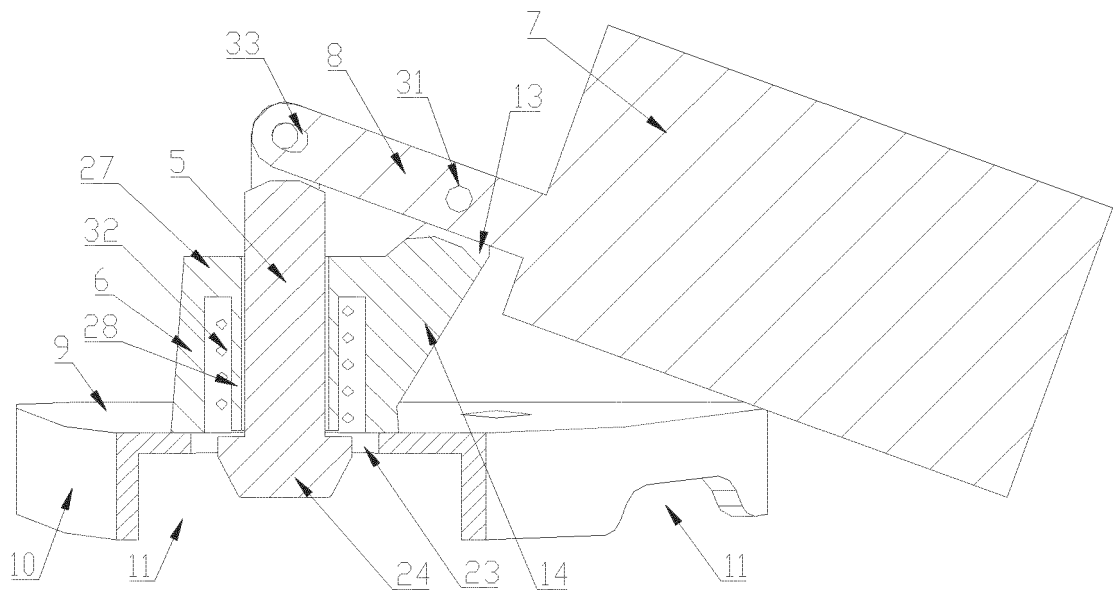

Fig. 7

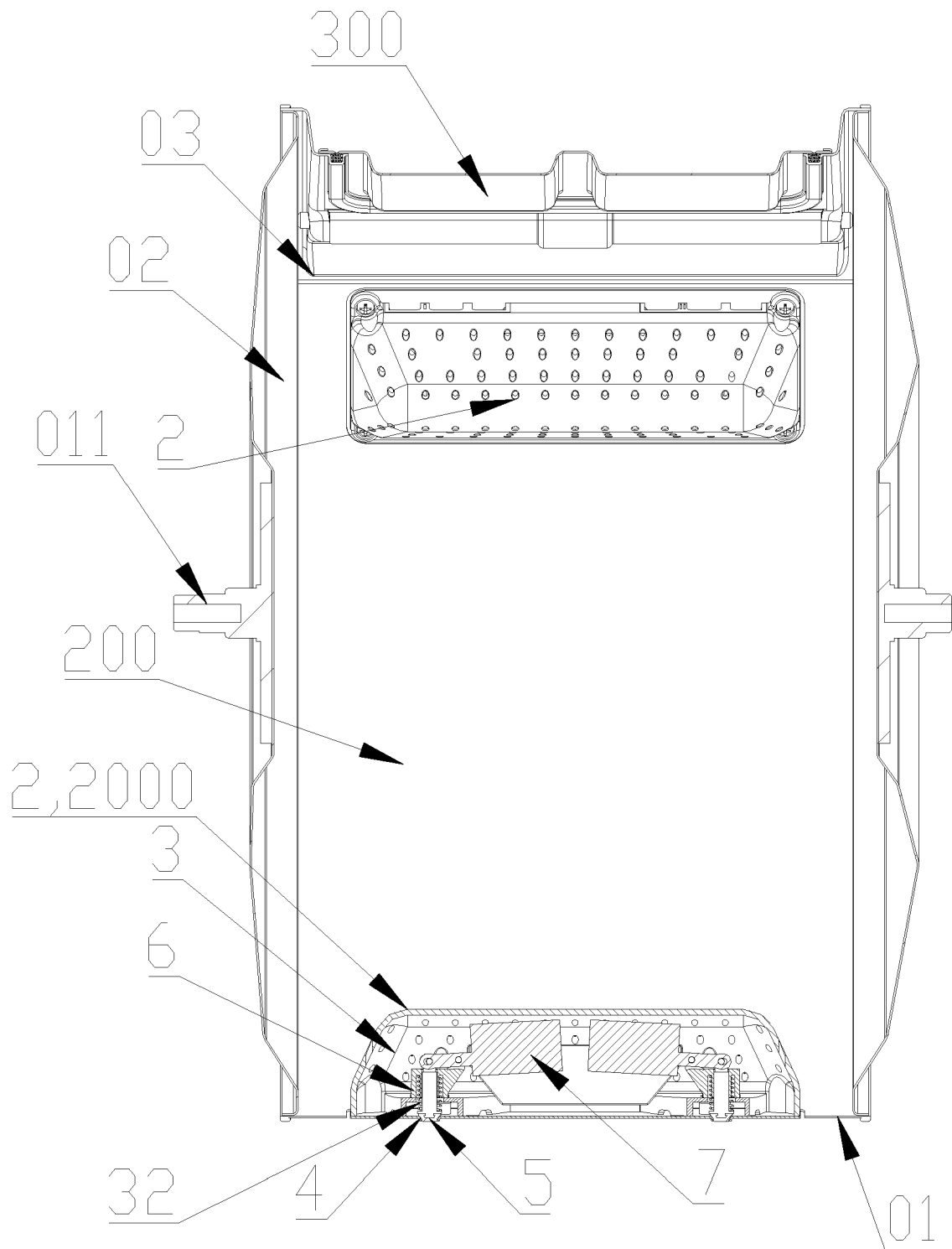

Fig. 8

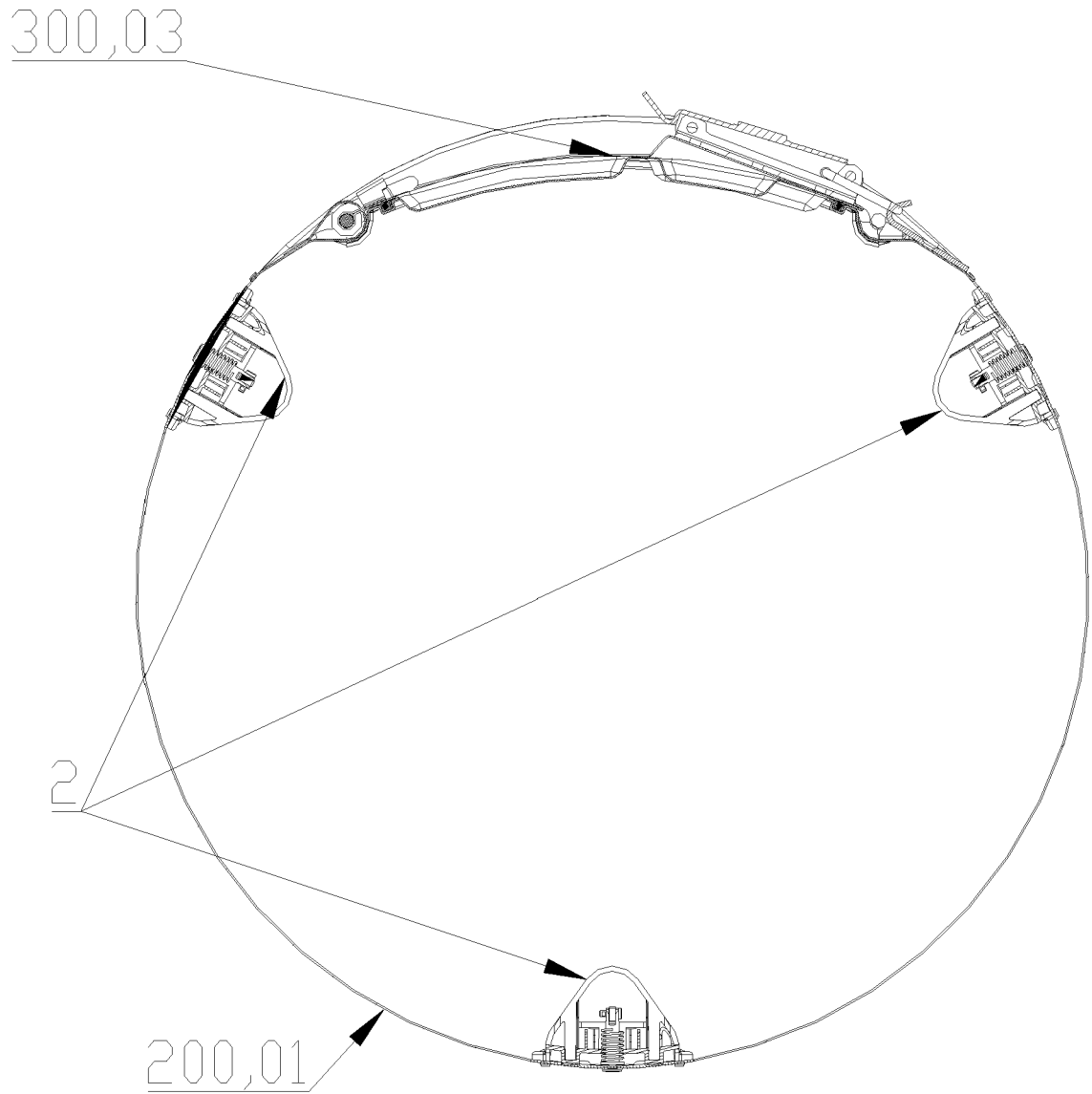

Fig. 9

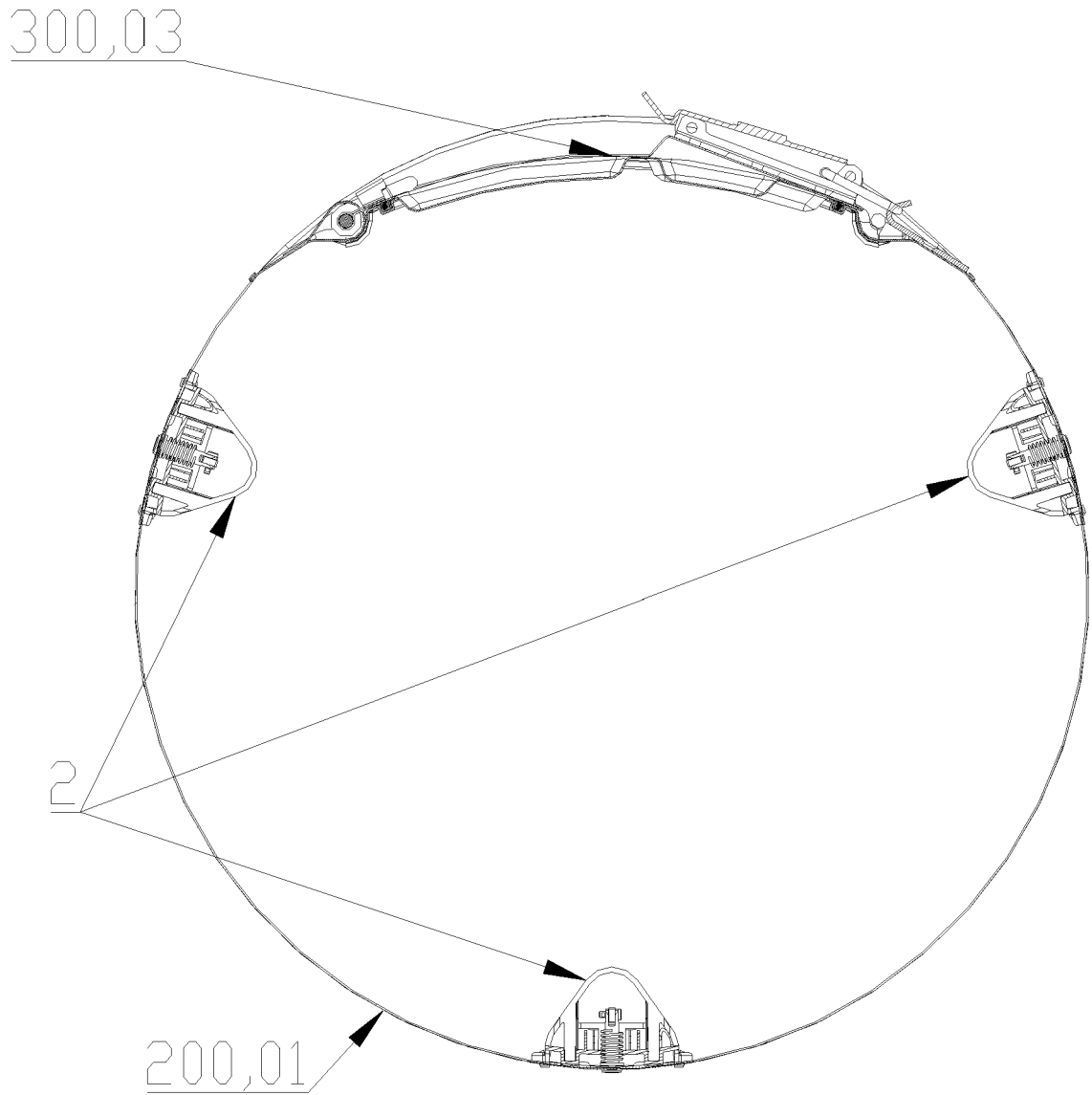

Fig. 10

REFERENCES CITED IN THE DESCRIPTION

This list of references cited by the applicant is for the reader's convenience only. It does not form part of the European patent document. Even though great care has been taken in compiling the references, errors or omissions cannot be excluded and the EPO disclaims all liability in this regard.

Patent documents cited in the description

- US 5115651 A [0008]
- CN 107523969 A [0009]