

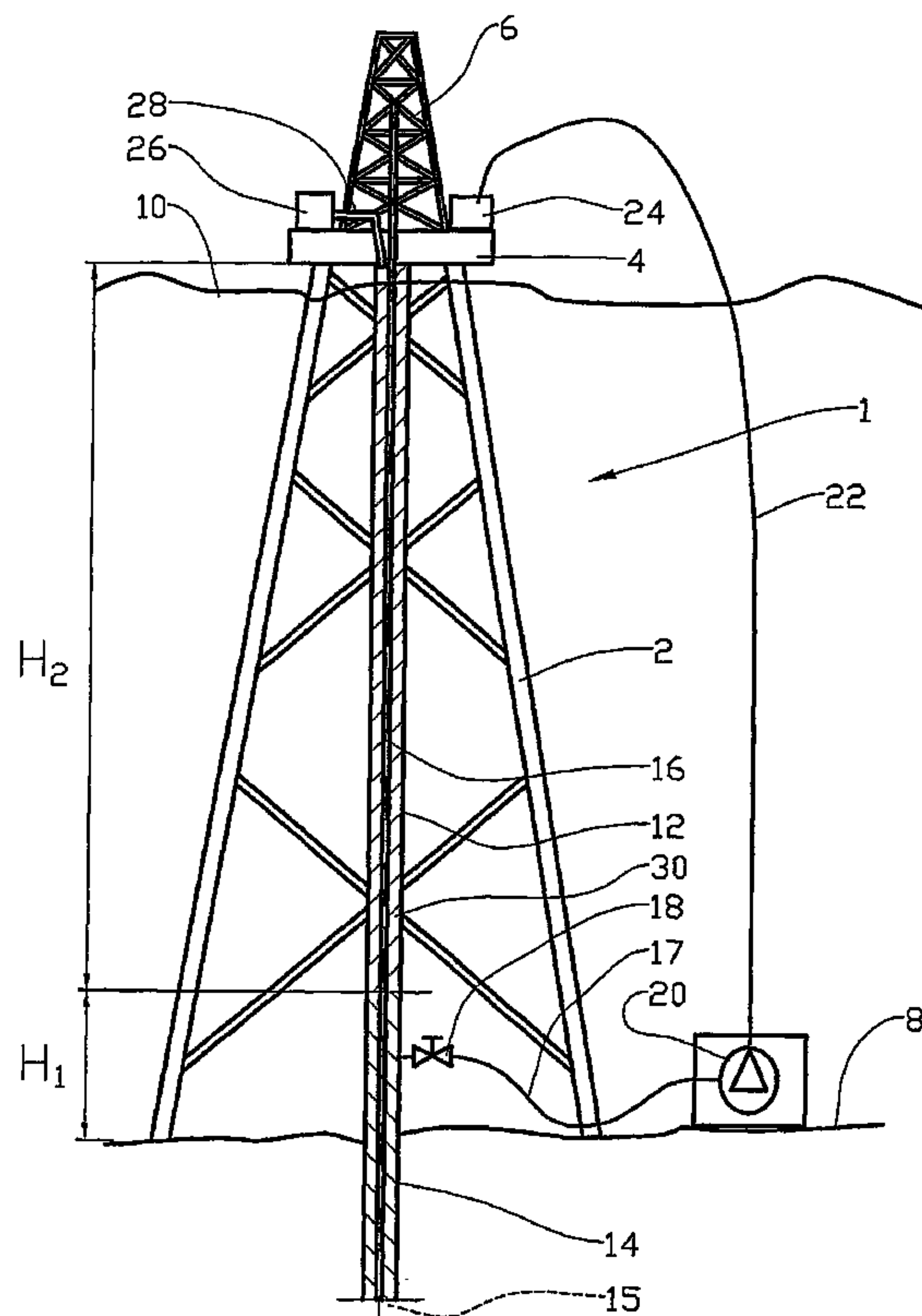

(86) Date de dépôt PCT/PCT Filing Date: 2004/11/24  
 (87) Date publication PCT/PCT Publication Date: 2005/06/09  
 (45) Date de délivrance/Issue Date: 2012/08/28  
 (85) Entrée phase nationale/National Entry: 2006/03/30  
 (86) N° demande PCT/PCT Application No.: NO 2004/000359  
 (87) N° publication PCT/PCT Publication No.: 2005/052307  
 (30) Priorité/Priority: 2003/11/27 (NO20035257)

(51) Cl.Int./Int.Cl. *E21B 21/08* (2006.01)  
 (72) Inventeur/Inventor:  
 STAVE, ROGER, NO  
 (73) Propriétaire/Owner:  
 AGR SUBSEA AS, NO  
 (74) Agent: BERESKIN & PARR LLP/S.E.N.C.R.L.,S.R.L.

(54) Titre : PROCÉDE ET DISPOSITIF DESTINES A REGULER LA PRESSION DU FLUIDE DE FORAGE  
 (54) Title: A METHOD AND DEVICE FOR CONTROLLING DRILLING FLUID PRESSURE



(57) **Abrégé/Abstract:**

A method and device for controlling drilling fluid pressure during subsea drilling, where drilling fluid is pumped down into a borehole (15) and then flows back to a drilling rig (1) via the lined and/or unlined sections of the borehole (15) and a liner (14), wherein the drilling fluid pressure is controlled by pumping drilling fluid out of the liner (14) at the seabed, and where the liner (14) annulus (30) above the drilling fluid is filled with a riser fluid having a density different from that of the drilling fluid.



(12) INTERNATIONAL APPLICATION PUBLISHED UNDER THE PATENT COOPERATION TREATY (PCT)

(19) World Intellectual Property  
Organization  
International Bureau



(43) International Publication Date  
9 June 2005 (09.06.2005)

PCT

(10) International Publication Number  
**WO 2005/052307 A1**

- (51) International Patent Classification<sup>7</sup>: **E21B 21/08**
- (21) International Application Number: PCT/NO2004/000359
- (22) International Filing Date: 24 November 2004 (24.11.2004)
- (25) Filing Language: English
- (26) Publication Language: English
- (30) Priority Data: 20035257 27 November 2003 (27.11.2003) NO
- (71) Applicant (for all designated States except US): **AGR SUBSEA AS** [NO/NO]; P.O. Box 163, N-5342 STRAUME (NO).
- (72) Inventor; and
- (75) Inventor/Applicant (for US only): **STAVE, Roger** [NO/NO]; Valahøgda 9, N-5355 KNARREVIK (NO).
- (74) Agent: **HÅMSØ PATENTBYRÅ ANS**; P.O. Box 171, N-4302 SANDNES (NO).
- (81) Designated States (unless otherwise indicated, for every kind of national protection available): AE, AG, AL, AM, AT, AU, AZ, BA, BB, BG, BR, BW, BY, BZ, CA, CH, CN, CO, CR, CU, CZ, DE, DK, DM, DZ, EC, EE, EG, ES, FI, GB, GD, GE, GH, GM, HR, HU, ID, IL, IN, IS, JP, KE, KG, KP, KR, KZ, LC, LK, LR, LS, LT, LU, LV, MA, MD, MG, MK, MN, MW, MX, MZ, NA, NI, NO, NZ, OM, PG, PH, PL, PT, RO, RU, SC, SD, SE, SG, SK, SL, SY, TJ, TM, TN, TR, TT, TZ, UA, UG, US, UZ, VC, VN, YU, ZA, ZM, ZW.
- (84) Designated States (unless otherwise indicated, for every kind of regional protection available): ARIPO (BW, GH, GM, KE, LS, MW, MZ, NA, SD, SL, SZ, TZ, UG, ZM, ZW), Eurasian (AM, AZ, BY, KG, KZ, MD, RU, TJ, TM), European (AT, BE, BG, CH, CY, CZ, DE, DK, EE, ES, FI, FR, GB, GR, HU, IE, IS, IT, LU, MC, NL, PL, PT, RO, SE,

[Continued on next page]

(54) Title: A METHOD AND DEVICE FOR CONTROLLING DRILLING FLUID PRESSURE

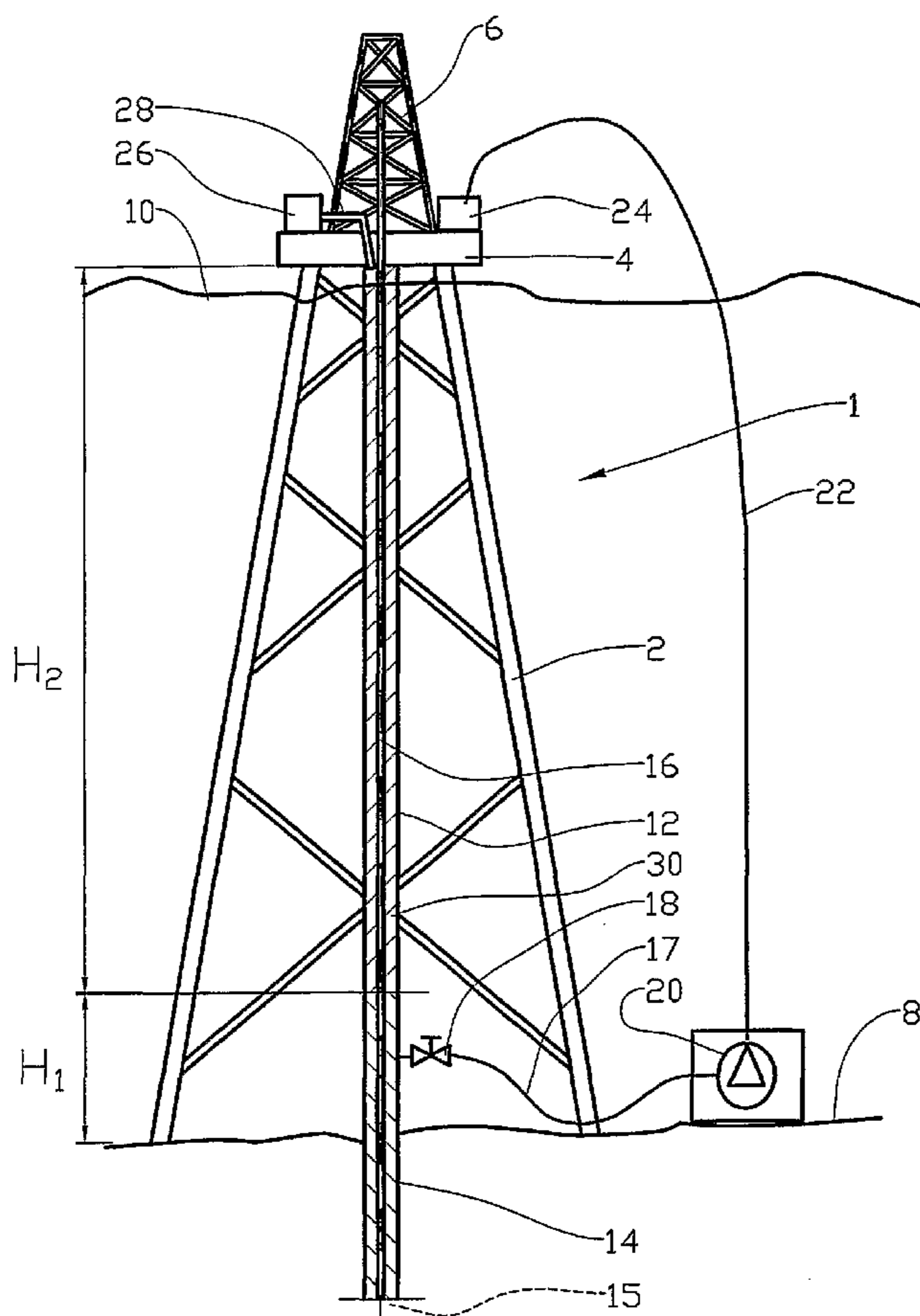

(57) Abstract: A method and device for controlling drilling fluid pressure during subsea drilling, where drilling fluid is pumped down into a borehole (15) and then flows back to a drilling rig (1) via the lined and/or unlined sections of the borehole (15) and a liner (14), wherein the drilling fluid pressure is controlled by pumping drilling fluid out of the liner (14) at the seabed, and where the liner (14) annulus (30) above the drilling fluid is filled with a riser fluid having a density different from that of the drilling fluid.

WO 2005/052307 A1

**WO 2005/052307 A1**



SI, SK, TR), OAPI (BF, BJ, CF, CG, CI, CM, GA, GN, GQ, GW, ML, MR, NE, SN, TD, TG).

*For two-letter codes and other abbreviations, refer to the "Guidance Notes on Codes and Abbreviations" appearing at the beginning of each regular issue of the PCT Gazette.*

**Published:**

- *with international search report*
- *before the expiration of the time limit for amending the claims and to be republished in the event of receipt of amendments*

A METHOD AND DEVICE FOR CONTROLLING DRILLING FLUID PRESSURE

This invention regards a method of controlling drilling fluid pressure. More particularly, it regards a method of controlling the drilling fluid pressure in an underground borehole during drilling of wells from a fixed offshore platform. The invention also regards a device for practicing the method.

During drilling operations, e.g. for petroleum production, the pressure head of drilling fluid present in the borehole and up to the platform, may cause the liquid pressure in the lower portion of the borehole to become too high.

Excessive drilling fluid pressures may result in the drilling fluid causing undesirable damage to the formation being drilled, e.g. through drilling fluid penetrating into the formation.

The formation may also include special geological formations (saline deposits etc.) that require the use of special drilling fluid in order to stabilise the formation.

According to prior art it is difficult to reduce the specific gravity of the drilling fluid in order to reduce the pressure to an acceptable level. In many cases it has proven difficult to achieve sufficient reduction in the specific gravity of the drilling fluid without causing an unacceptable degree of change in the physical properties of the drilling fluid, such as viscosity.

It is known to dilute the drilling fluid in a riser in order to reduce the drilling fluid pressure, see US 6536540.

10 When drilling from floating installations, it is also known to reduce the drilling fluid pressure in the well and the weight of the riser by pumping drilling fluid out of the riser at a level below the surface of the sea. Thus US patents 4063602 and 4291772 concern drilling vessels provided  
15 with a return pump for drilling fluid, wherein the drilling fluid is pumped out of the riser immediately above the seabed.

When using prior art it is difficult to monitor the volumetric flow in the borehole, as the annulus above the drilling fluid in the liner, or alternatively riser, is filled with gas, typically air. This gas-filled annulus may fill up with or become drained of drilling fluid without being easily observed.

The object of the invention is to remedy or reduce at least one of the disadvantages of prior art.

The object is achieved in accordance with the invention, by the characteristics stated in the description below and in the following claims.

When drilling from fixed platforms (drilling devices), a conductor is first driven into the seabed. When drilling a borehole from a fixed drilling device, drilling fluid is pumped through a drill string down to a drilling tool. The drilling fluid serves several purposes, of which one is to transport drill cuttings out of the borehole. Efficient transport of drill cuttings is conditional on the drilling fluid being relatively viscous.

The drilling fluid flows back through the annulus between the borehole wall, the liner mentioned above and the drill string, and up to the drilling rig, where the drilling fluid is treated and conditioned before being pumped back down to the borehole. In many cases, this will result in a head of pressure that is undesirable.

By coupling a pump to the liner near the seabed as described above, the returning drilling fluid can be pumped out of the annulus and up to the drilling rig. According to the invention the annular volume above the drilling fluid is filled with a riser fluid. Preferably, the density of the riser fluid is less than that of the drilling fluid.

The drilling fluid pressure at the seabed may be controlled from the drilling rig by selecting the inlet pressure to the pump. The height  $H_1$  of the column of drilling fluid above the seabed depends on the selected inlet pressure of the pump, the density of the drilling fluid and the density of the riser fluid, as the inlet pressure of the pump is equal to:

$$P = H_1 \times \gamma_b + H_2 \times \gamma_s$$

Where:

$\gamma_b$  = the density of the drilling fluid

$H_2$  = the height of the column of riser fluid

$\gamma_s$  = the density of the riser fluid

$H_1$  and  $H_2$  together make up the length of the riser section from the seabed and up to the deck of the drilling rig.

5 Filling the liner annulus with a riser fluid allows continuous flow quantity control of the fluid flowing into and out of the borehole. Thus it is relatively easy to detect e.g. drilling fluid flowing into the drilling formation.

10 It is furthermore possible to maintain a substantially constant drilling fluid pressure at the seabed, also when the drilling fluid density changes.

Choosing another inlet pressure to the pump will immediately cause the heights  $H_1$  and  $H_2$  to change according to the new pressure.

15 If so desired, the outlet from the annulus to the pump can be arranged at a level below the seabed, by coupling a first pump pipe to the annulus at a level below the seabed.

20 In order to prevent the drilling fluid pressure from exceeding an acceptable level, e.g. in the case of a pump trip, the riser may be provided with a dump valve. A dump valve of this type can be set to open at a particular pressure for outflow of drilling fluid to the sea.

The following describes a non-limiting example of a preferred method and device illustrated in the accompanying drawings,  
25 in which:

Figure 1 is a schematic view of a fixed drilling rig provided with a pump for the returning drilling fluid, the pump being coupled to the riser section near the seabed and the riser section being filled with a fluid of a different density than that of the drilling fluid; and

Figure 2 is similar to Figure 1, but here the drilling fluid fills a greater part of the riser section.

In the drawings reference number 1 denotes a fixed drilling rig comprising a support structure 2, a deck 4 and a derrick 6. The support structure 2 is placed on the seabed 8 and projects above the surface 10 of the sea.

A riser section 12 of a liner 14 extends from the seabed 8 up to the deck 4, while the liner 14 runs further down into a borehole 15. The riser section 12 is provided with required well head valves (not shown).

A drill string 16 projects from the deck 4 and down through the liner 14.

A first pump pipe 17 is coupled to the riser section 12 near the seabed 8 via a valve 18 and the opposite end portion of the pump pipe 17 is coupled to a pump 20 placed near the seabed 8. A second pump pipe 22 runs from the pump 20 up to a collection tank 24 for drilling fluid on the deck 4.

A tank 26 for a riser fluid communicates with the riser section 12 via a connecting pipe 28 at the deck 4. The connecting pipe 28 has a volume meter (not shown). Preferably, the density of the riser fluid is less than that of the drilling fluid.

The power supply to the pump 20 is via a cable (not shown) from the drilling rig 1 and the pressure at the inlet to the pump 20 is selected from the drilling rig 1. The pump 20 may optionally be driven hydraulically by means of oil that is  
5 circulated back to the drilling rig or by means of water that is dumped in the sea.

The drilling fluid is pumped down through the drill string 16 in a manner that is known *per se*, returning to the deck 4 via an annulus 30 between the liner 14 and the drill string 16.  
10 When the pump 20 is started, the drilling fluid is returned from the annulus 30 via the pump 20 to the collection tank 24 on the deck 4.

Riser fluid passes from the tank 26 into the annulus 30 in the riser section 12. The height  $H_1$  of the column of drilling  
15 fluid above the seabed 8 adjusts according to the selected inlet pressure of the pump 20, as described in the general part of the description.

The volume of riser fluid flowing into and out of the tank 26 is monitored, making it possible to keep a check e.g. on  
20 whether drilling fluid is disappearing into the well formation, or gas or liquid is flowing from the formation and into the system.

The invention makes it possible by use of simple means to achieve a significant reduction in the pressure of the drill-  
25 ing fluid in the borehole 15.

Figure 2 shows a situation where a higher inlet pressure has been selected for the pump, and where the heights  $H_1$  and  $H_2$  of the fluid columns have changed relative to the situation shown in Figure 1.

1. A method of controlling drilling fluid pressure during drilling offshore, comprising:
  - flowing drilling fluid down into a borehole in a sea bed beneath a body of water;
  - flowing drilling fluid back out of the borehole and into a conduit, wherein the conduit also contains a volume of riser fluid, wherein the riser fluid has a different density than the drilling fluid, and wherein the volume of the riser fluid is located above the drilling fluid starting at a demarcation zone between the two fluids in the conduit;
  - regulating a distance between a first level and the demarcation zone while flowing drilling fluid into the borehole and out of the borehole and into the conduit;
  - removing drilling fluid from the conduit utilizing a pump with an inlet in fluid communication with the conduit; and
  - regulating a pressure of the drilling fluid at the inlet to the pump to regulate the distance between the first level and the demarcation zone.
2. The method of claim 1, further comprising regulating the pressure at the inlet to be substantially constant.
3. A method of drilling offshore, comprising:
  - generating drill cuttings inside a borehole; and
  - executing claim 1 to transport the drill cuttings out of the borehole with the drilling fluid.
4. The method of claim 1, further comprising:
  - monitoring a quantity of riser fluid flowing into and out of the conduit.
5. The method of claim 1, further comprising comparing a quantity of drilling fluid and riser fluid flowing into and out of the conduit with a quantity of drilling fluid flowing into the borehole.
6. The method of claim 1, wherein the riser fluid has a lower density than the drilling fluid.

7. The method of claim 1, further comprising:  
decreasing the distance between the first level and the demarcation zone by lowering the pressure at the inlet of the pump.
8. The method of claim 1, further comprising:  
raising the pressure at the inlet of the pump to increase the distance between the first level and the demarcation zone.
9. A method of producing petroleum, comprising:  
executing claim 1;  
drilling into the sea bed for petroleum; and  
producing petroleum.
10. A method of producing petroleum, comprising:  
executing claim 2;  
drilling into the sea bed for petroleum; and  
producing petroleum.
11. A method of producing petroleum, comprising:  
executing claim 3;  
drilling into the sea bed for petroleum; and  
producing petroleum.
12. A method of producing petroleum, comprising:  
executing claim 4;  
drilling into the sea bed for petroleum; and  
producing petroleum.
13. A method of producing petroleum, comprising:  
executing claim 5;  
drilling into the sea bed for petroleum;

and producing petroleum.

14. A method of producing petroleum, comprising:  
executing claim 6;  
drilling into the sea bed for petroleum; and  
producing petroleum.
15. A method of producing petroleum, comprising:  
executing claim 7;  
drilling into the sea bed for petroleum; and  
producing petroleum.
16. A method of producing petroleum, comprising:  
executing claim 8;  
drilling into the sea bed for petroleum; and  
producing petroleum.
17. The method of claim 1, wherein the first level is about at a level of the sea bed.
18. The method of claim 1, wherein an outlet from the conduit to the pump is arranged below the sea bed,
19. A method of controlling drilling fluid pressure during drilling offshore, comprising:  
flowing drilling fluid down into a borehole in a sea bed beneath a body of water;  
flowing drilling fluid back out of the borehole and into a conduit, wherein the conduit also contains a volume of riser fluid, wherein the riser fluid has a different density than the drilling fluid, and wherein the volume of the riser fluid is located above the drilling fluid starting at a demarcation zone between the two fluids in the conduit;

regulating a distance between a first level and the demarcation zone while flowing drilling fluid into the borehole and out of the borehole and into the conduit;

and removing drilling fluid from the conduit utilizing a pump with an inlet in fluid communication with the conduit; and

regulating a pressure of the drilling fluid at the inlet to the pump to regulate the distance between the first level and the demarcation zone;

wherein the pressure at the inlet is regulated to be substantially constant so that the distance between the first level and the demarcation zone is substantially constant.

20. A method of producing petroleum, comprising:

executing claim 19;

drilling into the sea bed for petroleum; and

producing petroleum.

21. A device for controlling drilling fluid pressure during drilling offshore, comprising:

a drilling device in a bore hole in a sea floor beneath a body of water;

a drill string;

a first pump in fluid communication with the drill string, the first pump and the drill string being adapted to direct drilling fluid downward towards the drilling device and into the bore hole when the drilling device is located in the borehole;

an elongated annulus adapted to direct the drilling fluid, after it has been directed towards the drilling device and into the bore hole, upward away from the drilling device;

a second pump including a pump inlet, the second pump being in fluid communication with the annulus at an annulus outlet, the second pump being adapted to pump drilling fluid out of the annulus after the drilling fluid has been directed upward away from the drilling device, the second pump and annulus outlet being proximate the sea floor;

wherein the elongated annulus contains drilling fluid extending to a first level above the annulus outlet,

wherein the elongated annulus contains riser fluid extending upward from the first level above the annulus outlet, and

wherein the device is adapted to maintain the first level at a constant distance from the sea floor while drilling fluid is pumped out of the annulus.

22. The device according to claim 21, wherein the second pump is adapted to pump the drilling fluid out of the annulus under a controlled pressure of the drilling fluid with respect to the pump inlet.

23. The device according to claim 22, wherein the second pump is adapted to pump the drilling fluid out of the annulus while varying the pressure with respect to the pump inlet.

24. The device according to claim 21, wherein the device is adapted to maintain the first level at a constant distance from the sea floor while drilling fluid is pumped out of the annulus by regulating the pressure of the drilling fluid with respect to the pump inlet.

25. The device according to claim 21, wherein the device is adapted to move the first level to a smaller and greater distance from the sea floor while drilling fluid is pumped out of the annulus by respectively lowering and raising the pressure of the drilling fluid with respect to the pump inlet.

26. A method of controlling drilling fluid pressure during drilling offshore, comprising:

flowing drilling fluid down into a borehole in a sea bed beneath a body of water;

flowing drilling fluid back out of the borehole and into a conduit, wherein the conduit also contains a volume of riser fluid, wherein the riser fluid is different than the drilling fluid, and wherein the volume of the riser fluid is located above the drilling fluid starting at a demarcation zone between the two fluids in the conduit;

regulating a distance between a first level and the demarcation zone while flowing drilling fluid into the borehole and out of the borehole and into the conduit,

wherein the first level is at an outlet of the conduit through which the drilling fluid is extracted from the conduit;

removing the drilling fluid from the conduit through the outlet utilizing a pump with an inlet in fluid communication with the outlet; and

regulating a pressure of the drilling fluid at the inlet to the pump to regulate the distance between the first level and the demarcation zone.

27. A method of producing petroleum, comprising:

executing claim 26;

drilling into the sea bed for petroleum; and

producing petroleum.



2/2

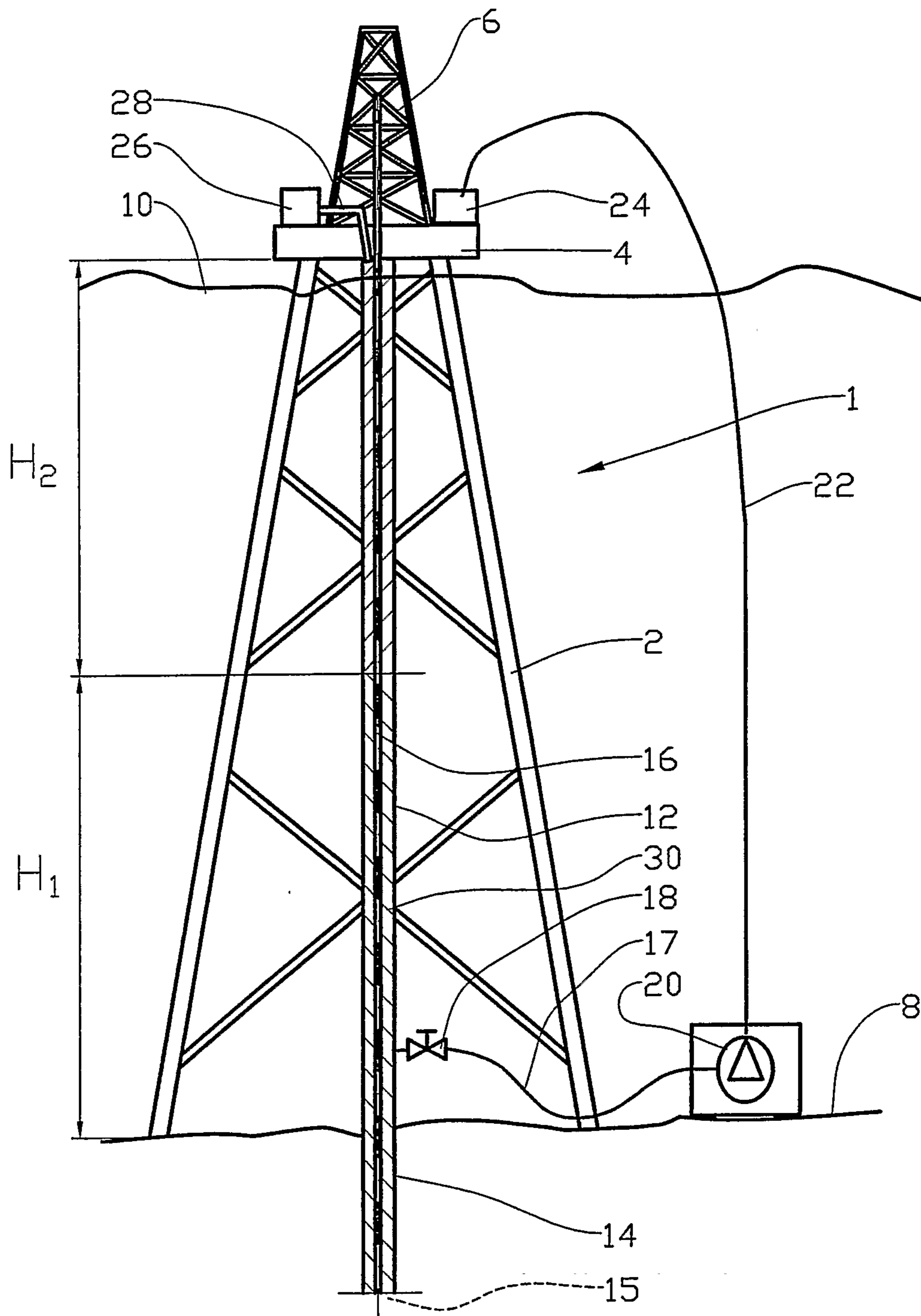

Fig. 2

