

[54] TOY HELICOPTER RIG

[75] Inventor: Jack L. Breneman, Orchard Park, N.Y.  
[73] Assignee: The Quaker Oats Company, Chicago, Ill.  
[\*\*] Term: 14 Years  
[21] Appl. No.: 219,945  
[22] Filed: Dec. 24, 1980

[51] Int. Cl. .... D21-01  
[52] U.S. Cl. .... D21/134; D21/85  
[58] Field of Search ..... 46/204, 205, 206, 207, 46/208, 209, 214, 75; D21/124, 128, 132, 134, 135-137, 140, 85

[56] References Cited  
U.S. PATENT DOCUMENTS

D. 247,985 5/1978 Breneman ..... D21/85  
D. 254,152 2/1980 Marden ..... D21/134  
D. 262,391 12/1981 Kanaoki ..... D21/85

OTHER PUBLICATIONS

Sears 1976 Wish Book, p. 444, Toy Transport at top of page.  
Sears Xmas Catalog, 1980, p. 473, item "C", Moto Cross Team.

Primary Examiner—Charles A. Rademaker  
Attorney, Agent, or Firm—Cumpston & Shaw

[57] CLAIM

The ornamental design for a toy helicopter rig, substantially as shown.

DESCRIPTION

FIG. 1 is a front perspective view of a toy helicopter rig showing my new design;  
FIG. 2 is a rear elevational view thereof;  
FIG. 3 is a front elevational view of the helicopter and trailer portions thereof;  
FIG. 4 is a rear elevational view of the truck portion thereof;  
FIG. 5 is a left-side elevational view thereof;  
FIG. 6 is a bottom plan view thereof.

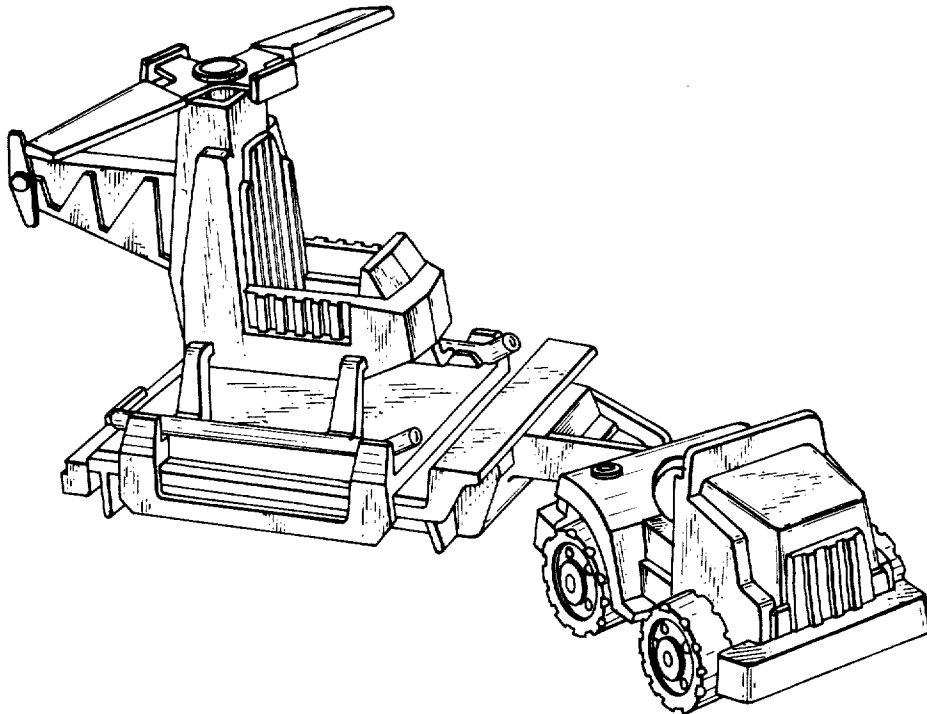

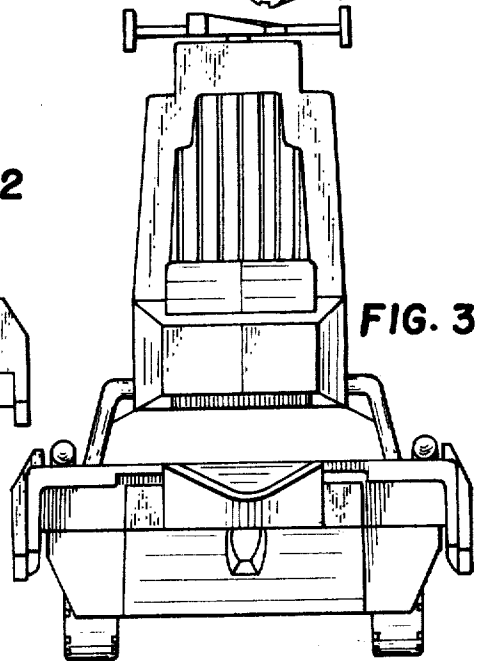
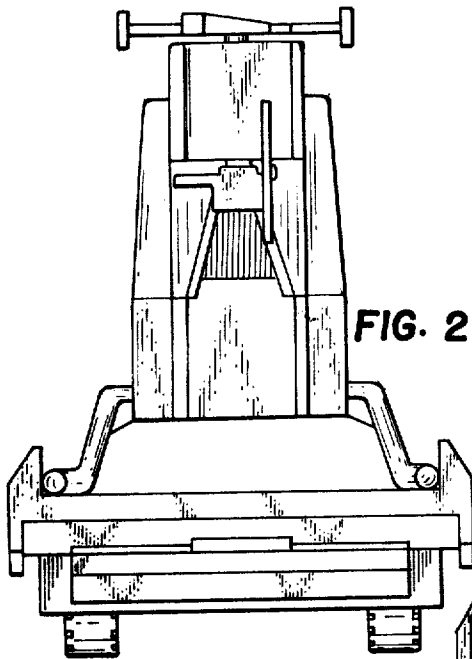
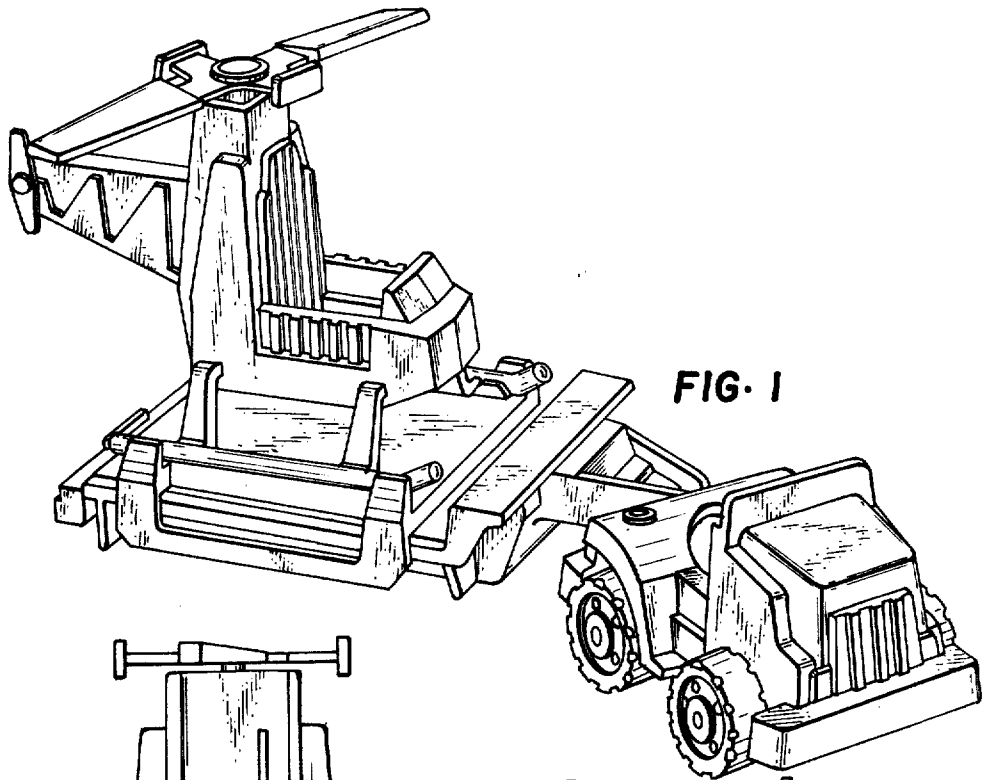

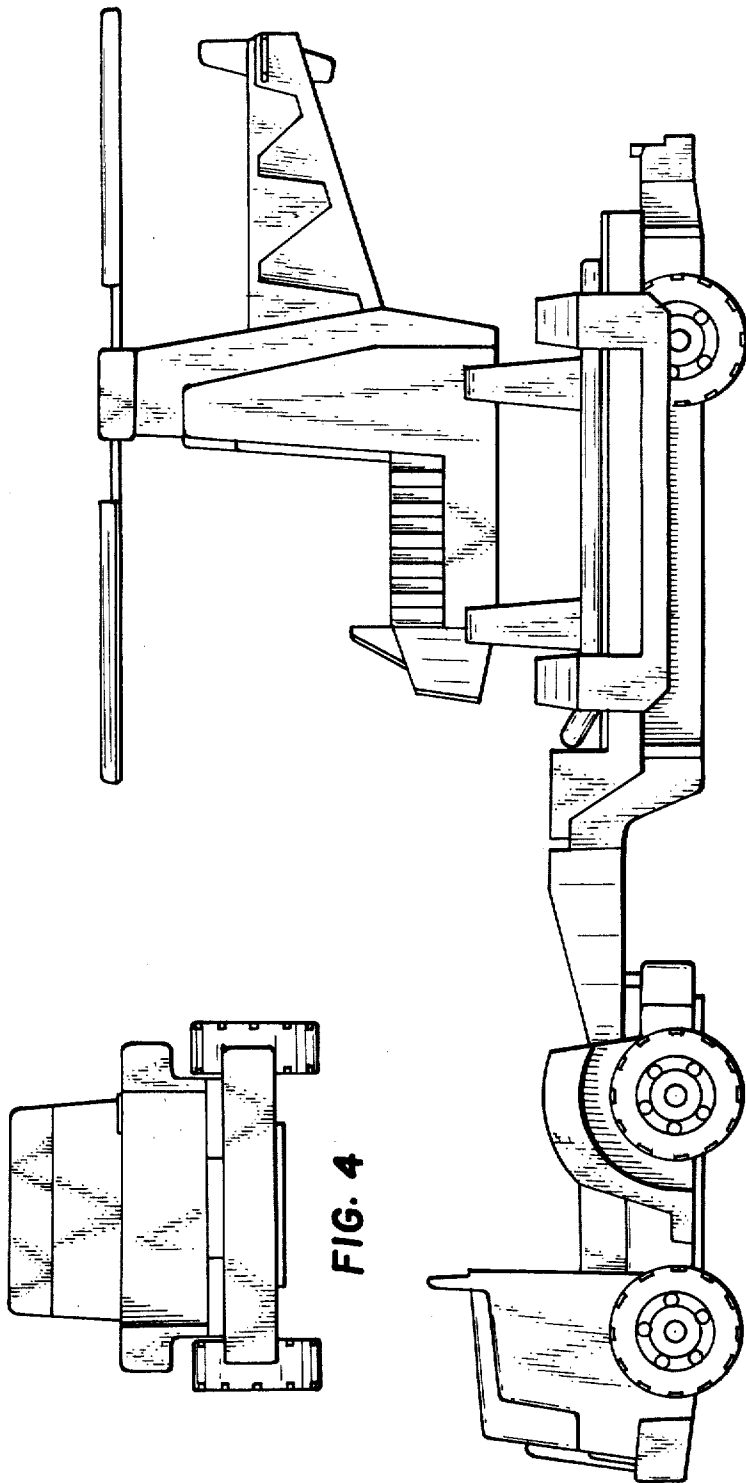

FIG. 4

FIG. 5

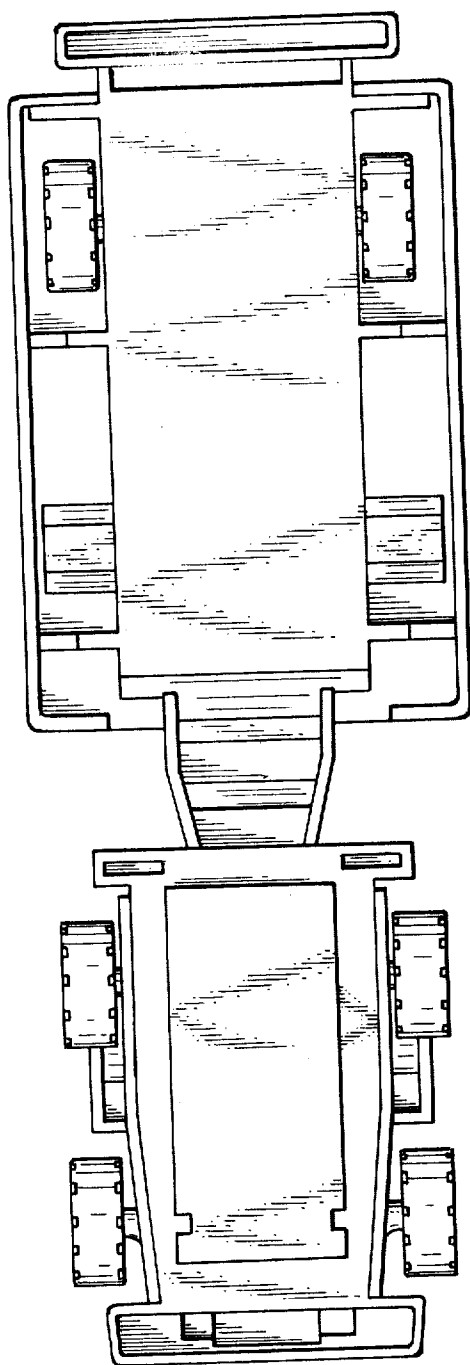

FIG. 6