

March 8, 1966

J. M. MARGULIS

3,239,179

WALL AND CEILING HANGER

Original Filed April 19, 1962

FIG. 1

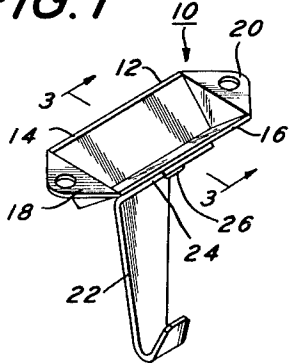

FIG. 2

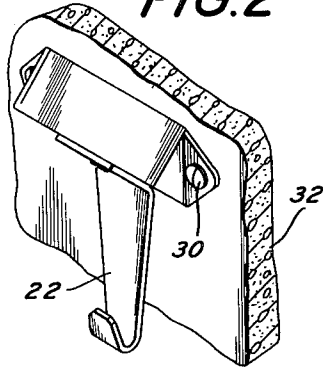

FIG. 3

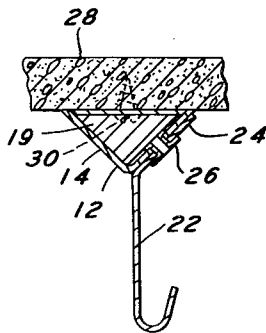

FIG. 4

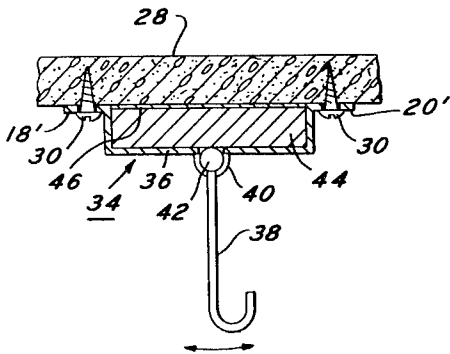

FIG. 5

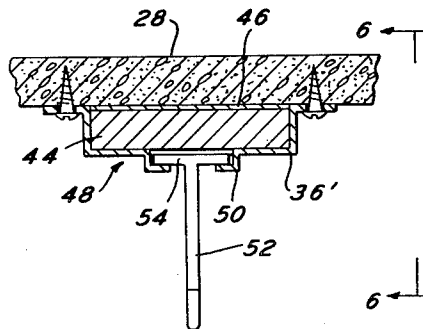

FIG. 6

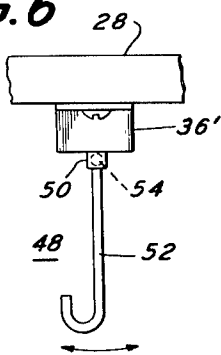

FIG. 7

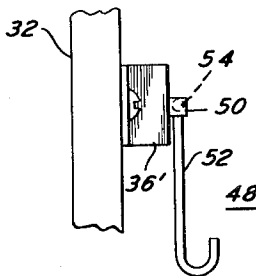
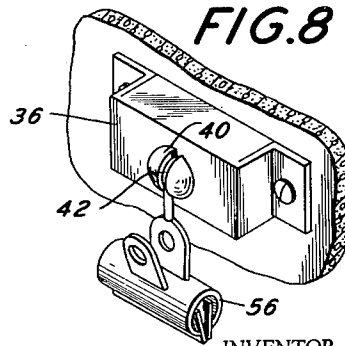

FIG. 8



INVENTOR  
JOSEPH M. MARGULIS  
BY *Seidel & Honda*  
ATTORNEY

1

3,239,179

## WALL AND CEILING HANGER

Joseph M. Margulis, % Jiffy Enterprises Inc.,  
150 N. 13th St., Philadelphia, Pa.Original application Apr. 19, 1962, Ser. No. 188,642, now  
Patent No. 3,190,599, dated June 22, 1965. Divided  
and this application Oct. 28, 1964, Ser. No. 407,197  
4 Claims. (Cl. 248—205)

This application is a division of application Serial No. 188,642, filed April 19, 1962, now Patent No. 3,190,599, issued June 22, 1965.

In general this invention relates to a new and improved wall and ceiling hanger and more particularly to a versatile hanger rotatably mounted for correct positioning when applied to a wall or ceiling, and is adapted to be fastened to the wall or ceiling by any suitable means.

The hanger of the present invention may be a hook or paper clip or the like which rotates into the correct operating position for wall or ceiling use. The hanger of the present invention is adapted to be secured to the wall or ceiling by screws, adhesive, or if the ceiling or wall is metallic it will be held in place by a magnet.

It is a general object of this invention to provide a new and improved wall or ceiling hanger.

It is another object of this invention to provide a simple wall and ceiling hanger which may be rotatably mounted for proper positioning on the wall or ceiling.

It is another object of this invention to provide a new and improved wall or ceiling hanger which may be fastened by magnetic, adhesive or screw fastening means.

Other objects will appear hereinafter.

For the purpose of illustrating the invention there is shown in the drawings forms which are presently preferred; it being understood, however, that this invention is not limited to the precise arrangements and instrumentalities shown.

FIGURE 1 is a perspective view of one embodiment of the present invention.

FIGURE 2 is a perspective view of the hanger of FIGURE 1 secured to a wall.

FIGURE 3 is a cross-sectional view taken along lines 3—3 of FIGURE 1 of the hanger of the present invention secured to a ceiling.

FIGURE 4 is a cross-sectional view of a second embodiment of the present invention secured to a ceiling.

FIGURE 5 is a cross-sectional view of a third embodiment of the present invention secured to a ceiling.

FIGURE 6 is an end view of the hanger as shown in FIGURE 5 taken along the lines 6—6 of FIGURE 5.

FIGURE 7 is an end view of the third embodiment shown in FIGURE 5 secured to a wall.

FIGURE 8 is a perspective view of the hanger of FIGURE 4 wherein the hook is replaced by a clamp.

In FIGURE 1 there is shown a first embodiment of the hanger of the present invention generally designated by the numeral 10.

The hanger 10 includes a housing or main body 12 shaped like a triangular prism with side walls 14 and 16. The side walls 14 and 16 have one edge in common. Their opposite edges are adapted to be placed in abutment with a wall or ceiling. Securing tabs 18 and 20 having holes therethrough, are positioned at the open end of the main body 12. The hanger 10 has a magnetic and pressure sensitive adhesive securing means 19 in the body 12 thereof as is shown in FIGURE 3. In the interest of clarity, means 19 have been removed from the showing in FIGURES 1 and 2. A flat hook 22 having an angular portion 24 is adapted to be secured to the side wall 16 of the body 12 by means of a rivet 26

2

centrally located in the side wall 16 and the angular portion 24. If desired, rivet 26 may be integral with portion 24.

The hook 22 is rotatably mounted upon the side wall 16 so that it may be utilized in two different positions. The first position is shown in FIGURE 2 in which the hanger 10 of the present invention is mounted by means of screws 30 passing through holes in the tabs 18 and 20 to a wall 32. In this position, the main portion of the hook 22 rests flatly against the wall 32. The angular portion 24 of the hook 22 is preferably at the same angle as the side wall 16 to the wall 32. Thus, the main portion of the hook 22 will be parallel to the wall 32 and, as the length of the portion 24 is equal to the width of the side wall 16 it will abut the wall 32.

By rotating the hook 180 degrees about the rivet 26, the hanger 10 of the present invention may be utilized for ceiling usage. The hook 22 will lie perpendicular to the ceiling 28 as shown in FIGURE 3.

A second embodiment 34 of the present invention is shown in FIGURE 4. The hanger 34 has a main body 36 with integral extending tabs 18' and 20'. A hook 38 is adapted to be connected to the base 36. The base 36 has an integral, outwardly extending, semi-spherical flange portion 40 adapted to receive a ball 42 integral with one end of the hook 38. The hook 38 passes through an opening in the flange portion 40 which allows movement of the hook 38 through a 180 degree arc. The portion 40 is preferably punched out of the plane of the base 36 and then cut so as to form the opening.

In the embodiment shown in FIGURE 4, the housing or main body 36 has a magnet 44 fixedly secured as by an epoxy glue to the casing 36. One face of the magnet 44 is parallel with the tabs 18' and 20'. On this face of the magnet 44 there is a pressure sensitive adhesive 46. When the hanger 34 is ready to be secured to the ceiling 28 it may be accomplished by any one of three means. Firstly it may be secured to the ceiling 28 by screws 30 passing through holes in the tabs 18 and 20. If the user does not desire to make holes in the ceiling 28, he may press the hanger 34 against the ceiling 28 so that the pressure sensitive adhesive coating 46 adheres the hanger 34 to the ceiling 28. Lastly, if the ceiling 28 is made of a ferromagnetic material, the magnet 44 will hold the hanger 34 securely in place.

It should be noted that the pressure sensitive adhesive coating 46 is extremely thin so as not to significantly diminish the magnetic attraction between the ceiling 28 and the magnet 44.

In the position shown in FIGURE 4, the hanger 38 is perpendicular to the ceiling 28. If the hanger 38 is replaced by a paper clip 56 as shown in FIGURE 8, the clip will rotate 90 degrees in either of two directions to be parallel to the wall 32.

In FIGURE 5 there is shown a hanger similar to the one shown in FIGURE 4. However, the hanger 52 shown in FIGURE 5 has a T-bar 54 at one end thereof rather than a ball. The T-bar 54 has its ends rotatably secured in spaced flanges 50 integral with the housing or main body 36' of the hanger 48. The flanges 50 allow 180 degree movement of the hook 52 so that it may be hung from the ceiling as shown in FIGURE 6 or from the wall as shown in FIGURE 7. The flanges 50 are preferably formed by punching portions of the bottom wall of the body 36' out of the plane thereof. The hanger 48 is secured to the wall 32 or ceiling 28 in the same manner as the hanger 34.

The present invention may be embodied in other specific forms without departing from the spirit or essential attributes thereof and, accordingly, reference should be made to the appended claims, rather than to the fore-

3

going specification as indicating the scope of the invention.

I claim:

1. A hanger for use on a wall or ceiling comprising a rigid hollow boxlike housing open on one side thereof, a magnet conforming to the shape of said housing fixedly secured within said housing, said magnet having one face thereof adjacent the open side of said housing, first and second sockets struck out from the side of said housing opposite said open side, said sockets being spaced apart to define a slot therebetween, said sockets being in open communication across said slot and with the interior of said housing, hanger means for hanging an object, said hanger means having an extending elongated portion, one end of said elongated portion being connected to a T-bar intermediate the ends of said T-bar, said T-bar being rotatably mounted in said sockets with said elongated portion extending through said slot, said hanger means being rotatable through 180° within said slot.

2. The hanger of claim 1 including a pressure sensitive adhesive coating on one surface of said magnet, and integral outwardly extending tabs on said housing having holes therethrough for receiving fasteners.

4

3. The hanger of claim 1 wherein said hanger means is a hook.

4. The hanger of claim 1 wherein said hanger means is a paper clip.

References Cited by the Examiner

UNITED STATES PATENTS

1,637,047	7/1927	Moore	-----	248—341
2,452,120	10/1948	Gorne	-----	248—341
2,484,173	10/1949	Leas	-----	248—341
2,943,246	6/1960	Riordan	-----	40—142 X
2,977,082	3/1961	Harris	-----	248—206
2,987,289	6/1961	Wamsley	-----	248—341
3,012,748	12/1961	Breslow	-----	248—205

FOREIGN PATENTS

1,027,060	2/1953	France.
-----------	--------	---------

CHANCELLOR E. HARRIS, *Primary Examiner.*

CLAUDE A. LE ROY, *Examiner.*