



(12) INTERNATIONAL APPLICATION PUBLISHED UNDER THE PATENT COOPERATION TREATY (PCT)

(19) World Intellectual Property  
Organization  
International Bureau(10) International Publication Number  
**WO 2015/031263 A1**(43) International Publication Date  
5 March 2015 (05.03.2015)

## (51) International Patent Classification:

**B62D 55/20** (2006.01) **B62D 55/32** (2006.01)  
**B62D 55/21** (2006.01)

## (21) International Application Number:

PCT/US2014/052539

## (22) International Filing Date:

25 August 2014 (25.08.2014)

## (25) Filing Language:

English

## (26) Publication Language:

English

## (30) Priority Data:

61/871,547 29 August 2013 (29.08.2013) US  
14/461,304 15 August 2014 (15.08.2014) US(71) Applicant: **CATERPILLAR INC.** [US/US]; 100 N.E. Adams St., Peoria, Illinois 61629 (US).(72) Inventors: **BREWER, Caroline M.**; 7011 N. Clayton Ct., Peoria, Illinois 61615 (US). **KAUFMANN, Gregory J.**; 1591 Upper Spring Bay Road, Metamora, Illinois 61548 (US). **THORSON, Timothy A.**; 109 S. Oklahoma Ave., Morton, Illinois 61550 (US). **STEINER, Kevin L.**; 10480 NorthPoint Rd., Tremont, Illinois 61568 (US). **DIEKEVERS, Mark S.**; 481 Town Hall Road, Germantown Hills, Illinois 61548 (US). **AKINLUA, Temitope O.**; 1118 N. Elmwood Ave., Peoria, Illinois 61606 (US). **MEYER, Robert L.**; 408 Elizabeth Point Drive, Metamora, Illinois 61548 (US).(74) Agents: **PARKER, Timothy A.** et al.; c/o Black Hills IP, P.O. Box 2409, Minneapolis, Minnesota 55402 (US).

(81) Designated States (unless otherwise indicated, for every kind of national protection available): AE, AG, AL, AM, AO, AT, AU, AZ, BA, BB, BG, BH, BN, BR, BW, BY, BZ, CA, CH, CL, CN, CO, CR, CU, CZ, DE, DK, DM, DO, DZ, EC, EE, EG, ES, FI, GB, GD, GE, GH, GM, GT, HN, HR, HU, ID, IL, IN, IR, IS, JP, KE, KG, KN, KP, KR, KZ, LA, LC, LK, LR, LS, LT, LU, LY, MA, MD, ME, MG, MK, MN, MW, MX, MY, MZ, NA, NG, NI, NO, NZ, OM, PA, PE, PG, PH, PL, PT, QA, RO, RS, RU, RW, SA, SC, SD, SE, SG, SK, SL, SM, ST, SV, SY, TH, TJ, TM, TN, TR, TT, TZ, UA, UG, US, UZ, VC, VN, ZA, ZM, ZW.

(84) Designated States (unless otherwise indicated, for every kind of regional protection available): ARIPO (BW, GH, GM, KE, LR, LS, MW, MZ, NA, RW, SD, SL, ST, SZ, TZ, UG, ZM, ZW), Eurasian (AM, AZ, BY, KG, KZ, RU, TJ, TM), European (AL, AT, BE, BG, CH, CY, CZ, DE, DK, EE, ES, FI, FR, GB, GR, HR, HU, IE, IS, IT, LT, LU, LV, MC, MK, MT, NL, NO, PL, PT, RO, RS, SE, SI, SK, SM, TR), OAPI (BF, BJ, CF, CG, CI, CM, GA, GN, GQ, GW, KM, ML, MR, NE, SN, TD, TG).

## Published:

— with international search report (Art. 21(3))

[Continued on next page]

(54) Title: TRACK JOINT ASSEMBLIES

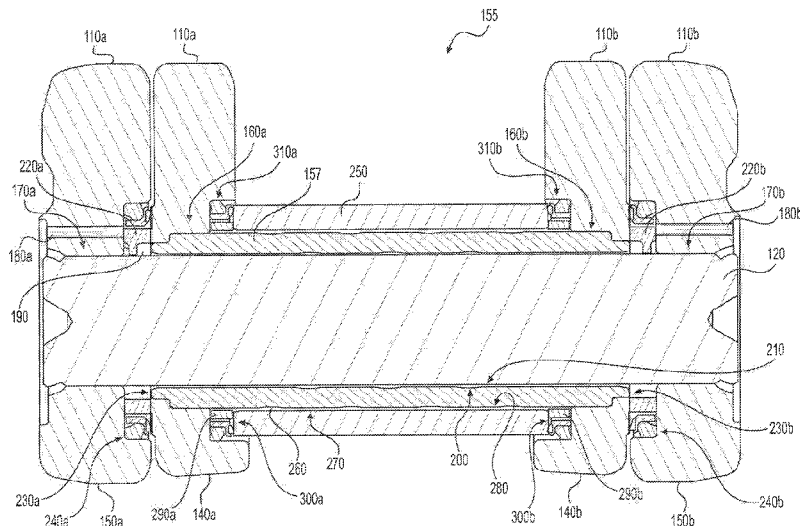


FIG. 4

(57) Abstract: Disclosed are various exemplary embodiments of a track joint assembly. In one exemplary embodiment, the track joint assembly may include a first link having a first bore. The track joint assembly may also include a second link having a second bore including first and second portions. The first and second portions may have different diameters. In addition, the track joint assembly may include a solid pin positioned at least partially within the first bore. The track joint may also include a bushing positioned coaxially around the pin. The bushing may include an axial end portion disposed in and contacting the first portion of the second bore. The bushing may also include an axial end-adjacent portion disposed in and contacting the second portion of the second bore. An outer diameter of the end-adjacent portion may be larger than an outer diameter of the end portion.

WO 2015/031263 A1

**WO 2015/031263 A1** 

---

- *before the expiration of the time limit for amending the claims and to be republished in the event of receipt of amendments (Rule 48.2(h))*

Description

## TRACK JOINT ASSEMBLIES

Technical Field

The present disclosure relates generally to track assemblies and,  
5 more particularly, to track joint assemblies for joining links of the track  
assemblies.

Background

Many earth-working machines, such as, for example, loaders,  
tractors, and excavators, include tracked undercarriages to facilitate movement  
10 of the machines over ground surfaces. Such undercarriages include drive  
sprockets that rotate track assemblies about one or more idlers or other guiding  
components to propel the machines over the ground surfaces. Each track  
assembly includes a pair of parallel chains, each made up of a series of links,  
joined to each other by pins and/or bushings (the combination of which is  
15 sometimes referred to as a cartridge assembly). Due to extreme wear from  
abrasion and impacts experienced during use, undercarriage maintenance costs  
often constitute more than one quarter of the total costs associated with operating  
the earth-working machines.

Fig. 1 provides an example of a prior art cartridge assembly 10  
20 for coupling links, which is disclosed by U.S. Patent Application Publication No.  
2012/0267947 by Johannsen et al. As shown, cartridge assembly 10 includes a  
pin 12 accommodated within an inner bushing 14, which is, in turn,  
accommodated within an outer bushing 16. End portions 17a, 17b of inner  
bushing 14 are surrounded by inserts 19a, 19b, and end portions 21a, 21b of pin  
25 12 are surrounded by collars 23a, 23b. Pin 12 has a lubricant channel 25, which  
serves as a reservoir for lubricant and delivers lubricant to a gap between pin 12  
and inner bushing 14, and to a gap between inner bushing 14 and outer bushing  
16. The lubricant is retained by seals 27a, 27b positioned between outer bushing  
16 and inserts 19a, 19b, and by seals 29a, 29b positioned between inserts 19a,  
30 19b and collars 23a, 23b.

Cartridge assembly 10 may provide certain benefits that are  
particularly important for some applications. However, it may have certain

drawbacks. For example, manufacturing pin 12 to include channel 25 may be complicated and costly. As another example, manufacturing links large enough to accommodate inserts 19a, 19b and collars 23a, 23b (as opposed to just pin 12 and inner bushing 14) may require an excessive amount of material. The disclosed embodiments may help solve these problems.

## 5 Summary

One disclosed embodiment relates to a track joint assembly, comprising: a first link having a first bore; a second link having a second bore, the second bore including first and second bore portions, the first and second bore portions having different diameters; a solid pin positioned at least partially within the first bore; and a bushing positioned coaxially around the pin, and including:  
10 an axial end portion disposed in and directly contacting the first bore portion of the second bore; and an axial end-adjacent portion disposed in and directly contacting the second bore portion of the second bore, wherein an outer diameter of the end-adjacent portion is larger than an outer diameter of the end portion.

Another disclosed embodiment relates to a track joint assembly, comprising: a first  
15 link having a first bore, the first bore including first and second bore portions, the first and second bore portions having different diameters; a second link having a second bore; and a bushing including: a first axial end portion disposed in and directly contacting the first bore portion of the first bore; a first axial end-adjacent portion disposed in and directly contacting the second bore portion of the first bore; and a second axial end portion disposed in and contacting the second bore,  
20 wherein an outer diameter of the first end-adjacent portion is larger than an outer diameter of the first axial end portion.

A further disclosed embodiment relates to a track joint assembly, comprising: a first link having a first bore; a second link having a second bore; and a bushing including: a first axial end portion directly contacting the first bore; a second axial end portion directly contacting the  
25 second bore; and a middle portion between the first and second axial end portions, wherein the middle portion has an outer diameter greater than an outer diameter of the first and second axial end portions.

## Brief Description of the Drawings

Fig. 1 is a view of a prior art cartridge assembly;

Fig. 2 is a perspective view of a track assembly according to the present disclosure;  
Fig. 3 is a cutaway view of a track joint assembly of the track assembly of

Fig. 2;

Fig. 4 is a cross-section of the track joint assembly of Fig. 3;

5

Fig. 5 is an enlarged view of a portion of Fig. 4;

Fig. 6 is another enlarged view of a portion of Fig. 4;

Fig. 7 is a perspective view of a thrust ring of the track joint assembly of

Fig. 3;

Fig. 8 is a side view of the thrust ring of Fig. 7;

10

Fig. 9 is a cross-section of the thrust ring of Fig. 7;

Fig. 10 is a cross-section of another track joint assembly according to the present disclosure; and

Fig. 11 is a cross-section of yet another track joint assembly according to the present disclosure.

15 Detailed Description

Fig. 2 illustrates an exemplary track assembly 100 for a track-type machine. For example, the track-type machine may be a loader, a tractor, an excavator, a tank, or another mobile machine having track-type traction devices. When operated, a drive sprocket of the track-type machine (not shown) may rotate track assembly 100 about one or more idlers or other guiding  
20 components (not shown) to facilitate movement of the track-type machine.

Track assembly 100 may include a series of links 110a joined to each other (as first and second links of the links 110a) and to a series of links 110b by laterally disposed pins 120. As shown, links 110a and 110b may be offset links. That is, they may have inwardly offset ends 140a, 140b and outwardly offset ends 150a, 150b. An inwardly offset end 140a, 140b of each link 110a, 110b may be joined to an outwardly offset end 150a, 150b of each adjacent link 110a, 110b. In addition, an inwardly offset end 140a of each link 110a may be joined to an inwardly offset end 140b of an opposing link 110b, and an outwardly offset end 150a of each link 110a may be joined to an outwardly offset end 150b of an opposing link 110b. It should be understood, however, that links 110a and 110b need not be offset links. Rather, in some embodiments, links 110a and 110b may be inner links and outer links. In such embodiments, both ends of each opposing pair of inner links would be sandwiched between ends of opposing outer links, as is known in the art.

Referring to Figs. 3 and 4, an individual track joint assembly 155 of track assembly 100 may include two links 110a joined to two links 110b. As shown, inwardly offset ends 140a, 140b of links 110a, 110b may be secured to a joint bushing 157, which may be at least partially positioned within bushing bores 160a, 160b of offset ends 140a, 140b. Similarly, outwardly offset ends 150a, 150b of links 110a, 110b may be secured to a pin 120, which may be at least partially positioned within pin bores 170a, 170b of offset ends 150a, 150b. For example, the securing may be by way of press-fits. Specifically, bushing 157 may be press-fit into bushing bores 160a, 160b, and pin 120 may be press-fit into pin bores 170a, 170b. Alternatively, the securing may be by way of welds, snap rings, or other mechanisms known in the art.

As shown, bushing 157 may be positioned coaxially around pin 120, and may rotate relative to pin 120, allowing inwardly offset ends 140a, 140b to pivot relative to outwardly offset ends 150a, 150b as track assembly 100 rotates. In order to facilitate such rotation, one or both of bushing 157 and pin 120 may be coated with diamond like carbon or electroless nickel, or may be carburized, nitrided, or polished to reduce friction between bushing 157 and pin 120. Alternatively or additionally, a lubricating fluid may be situated between bushing 157 and pin 120.

The lubricating fluid may be added through openings 180a, 180b in links 110a, 110b, and may be contained in a lubricating fluid cavity 190 at least partially defined by a generally cylindrical inner surface 200 of inner bushing 157 and a generally cylindrical outer surface 210 of pin 120 facing

surface 200. Unlike the prior art cartridge assembly discussed above, lubricating fluid cavity 190 may not extend into an interior cavity of pin 120, as pin 120 may be solid. Since pin 120 may not contain lubricating fluid, lubricating fluid cavity 190 may extend into and be at least partially defined by one or more  
5 recesses in surface 200 or surface 210. Alternatively or additionally, lubricating fluid cavity 190 may extend into and be at least partially defined by thrust rings 220a, 220b positioned at axial ends 230a, 230b of bushing 157. Thrust rings 220a, 220b may transmit axial load between adjacent links 110a, 110b, and may limit axial load on seal assemblies 240a, 240b, which may be positioned radially  
10 outward of thrust rings 220a, 220b and form hermetic seals between adjacent links 110a, 110b to retain the lubricating fluid in lubricating fluid cavity 190.

Still referring to Figs. 3 and 4, in some embodiments, track joint assembly 155 may also include an outer bushing 250, which may be positioned coaxially around bushing 157 (making bushing 157 an inner bushing) to engage  
15 a drive sprocket (not shown) that rotates track assembly 100. Outer bushing 250 may rotate relative to inner bushing 157 when it engages the drive sprocket, reducing wear on outer bushing 250 caused by sliding motion between outer bushing 250 and the drive sprocket. Such rotation may be facilitated by coating one or both of outer bushing 250 and inner bushing 157 with diamond like  
20 carbon or electroless nickel, or by carburizing, nitriding, or polishing one or both of outer bushing 250 and inner bushing 157 to reduce friction between outer bushing 250 and inner bushing 157. Alternatively or additionally, lubricating fluid may be situated between outer bushing 250 and inner bushing 157. This lubricating fluid may be the same as or different from the lubricating fluid  
25 situated between inner bushing 157 and pin 120.

The lubricating fluid may be added during assembly of track joint assembly 155, and may be contained in a lubricating fluid cavity 260 at least partially defined by a generally cylindrical inner surface 270 of outer bushing 250 and a generally cylindrical outer surface 280 of inner bushing 157 facing  
30 surface 270. Lubricating fluid cavity 260 may be isolated from lubricating fluid cavity 190 so that a leak in lubricating fluid cavity 260 does not impact lubricating fluid cavity 190 (and vice versa). Lubricating fluid cavity 260 may extend into and be at least partially defined by one or more recesses in surface 270 or surface 280. Alternatively or additionally, lubricating fluid cavity 260

may extend into and be at least partially defined by thrust rings 290a, 290b, which may be disposed in bushing bores 160a, 160b, and which may be positioned at axial ends 300a, 300b of outer bushing 250 and coaxially around inner bushing 157. Thrust rings 290a, 290b may limit axial load on seal assemblies 310a, 310b, which may form hermetic seals between outer bushing 250 and links 110a, 110b to retain the lubricating fluid in lubricating fluid cavity 260.

As shown in Fig. 5 and discussed above, bushing 157 may be press-fit into bushing bores 160a, 160b. In particular, axial end portions 320a, 320b of bushing 157 may be disposed in and press-fit into outer portions 330a, 330b of bushing bores 160a, 160b. Additionally, axial end-adjacent portions 340a, 340b of bushing 157 may be disposed in and press-fit into central portions 350a, 350b of bushing bores 160a, 160b. Thus, axial end portions 320a, 320b may contact outer portions 330a, 330b, and axial end-adjacent portions 340a, 340b may contact central portions 350a, 350b. In some embodiments, outer diameters 360a, 360b of end-adjacent portions 340a, 340b may be larger than outer diameters 370a, 370b of end portions 320a, 320b. Accordingly, outer portions 330a, 330b may have different diameters than central portions 350a, 350b to account for the differences between diameters 360a, 360b and 370a, 370b. In other embodiments, however, outer diameters 360a, 360b of end-adjacent portions 340a, 340b may be the same as outer diameters 370a, 370b of end portions 320a, 320b, in which case outer portions 330a, 330b might have the same diameters as central portions 350a, 350b.

Referring again to Fig. 5, inner surface 200 of bushing 157 may include a generally cylindrical inner surface 380 defining a bore 390. Pin 120 may be positioned at least partially within bore 390 and its motion may thus be constrained by surface 380. Accordingly, surface 380 may be a bearing surface. As shown, inner surface 380 may include three valley-shaped recesses 400, each extending into and along a circumference of bushing 157, and a sum of lengths 410 of recesses 400, in an axial direction of bushing 157, may be approximately 27% of a length 420 of surface 380. It should be understood, however, that inner surface 380 may include a different number of recesses or differently sized recesses. For example, inner surface 380 may include between one and twenty recesses 400, and the sum of lengths 410 may be between approximately 5% and

approximately 75% of length 420. It is contemplated, however, that, by using a plurality of recesses 400 (as opposed to a single larger recess 400), the structural integrity of bushing 157 may be maintained. It should also be understood that inner surface 380 may include differently positioned or shaped recesses. For example, inner surface 380 may include valley-shaped recesses extending along the axial direction of bushing 157. Alternatively, inner surface 380 may include helical recesses extending along both circumferential and axial directions of bushing 157.

Outer surface 280 of bushing 157 may include a generally cylindrical outer surface 430, which may constrain motion of outer bushing 250. Thus, surface 430 may be a bearing surface. As shown, outer surface 430 may include a different number of recesses than inner surface 380, and its recesses may be offset, in the axial direction of bushing 157, relative to those of inner surface 380 in order to avoid compromising bushing 157's structural integrity. Specifically, outer surface 430 may include four valley-shaped recesses 440, each extending into and along a circumference of bushing 157, and a sum of lengths 450 of recesses 440, in the axial direction of bushing 157, may be approximately 37% of a length 460 of surface 430. It should be understood, however, that outer surface 430 may include a different number of recesses or differently sized recesses. For example, outer surface 430 may include between one and twenty recesses 440, and the sum of lengths 450 may be between approximately 7% and approximately 38% of length 460. It is contemplated, however, that, by using a plurality of recesses 440 (as opposed to a single larger recess 440), the structural integrity of bushing 157 may be maintained. It should also be understood that outer surface 430 may include differently positioned or shaped recesses. For example, outer surface 430 may include valley-shaped recesses extending along the axial direction of bushing 157. Alternatively, outer surface 430 may include helical recesses extending along both circumferential and axial directions of bushing 157. In yet another alternative, outer surface 430 may include recesses that are aligned with (as opposed to offset relative to) those of inner surface 380.

As shown in Fig. 6 and discussed above, thrust ring 220a may be positioned at axial end 230a of bushing 157. Thrust ring 220a may include a generally cylindrical outer surface 465, which may support seal assembly 240a.

In addition, thrust ring 220a may include a generally cylindrical inner surface 470, which may at least partially define lubricating fluid cavity 190. As shown, an outer diameter 480 of outer surface 465 (and thus thrust ring 220a) may be larger than outer diameter 370a of axial end portion 320a of inner bushing 157.

5 Specifically, outer diameter 480 may be approximately 1.16 times outer diameter 370a. Alternatively, outer diameter 480 may be another size. For example, outer diameter 480 may be between approximately 1.1 and approximately 2.0 times outer diameter 370a.

Thrust ring 220a's larger diameter may ensure that seal assembly  
10 240a contacts only links 110a, not bushing 157. Specifically, seal assembly 240a may contact a sealing portion 485 of link 110a at a seal-link interface 490. As shown, an outer diameter 500 of seal-link interface 490 may be approximately 1.20 times outer diameter 370a of axial end portion 320a of inner bushing 157. Alternatively, outer diameter 500 may be another size. For  
15 example, outer diameter 500 may be between approximately 1.05 and approximately 2.5 times outer diameter 370a.

Sealing portion 485 may include a sealing surface 505 of inwardly offset end 140a of link 110a that faces outwardly offset end 150a of adjacent link 110a. It may be annular and surround axial end 230a of axial end  
20 portion 320a, and may include a different material from other portions of link 110a. That is, it may have different material properties from other portions of link 110a. The different material may have a different wear resistance than material of the other portions, and may better resist wear and corrosion resulting from sealing portion 485's contact with seal assembly 240a. For example, the  
25 different material may be an electroless nickel coating, a nitride coating, or a carburized coating. In some embodiments, the different material may be a washer 510 attached to link 110a. For example, washer 510 may be press-fit into another portion of link 110a, welded to the other portion, fastened to the other portion with an adhesive, or held in the other portion by an annular biasing  
30 member positioned at an inner diameter or an outer diameter of washer 510. In other embodiments, the different material may be clad (e.g., laser clad) to the material of the other portion of link 110a. Alternatively, the different material may be a laser hardened or a thermal sprayed material. In yet another alternative, the different material may be a thin film coating of, for example,

chromium nitride, amorphous diamondlike carbon, or tetrahedral amorphous carbon.

Referring to Figs. 7-9, thrust ring 220a may include axial ends 520-1 and 520-2 connecting outer surface 465 of thrust ring 220a to inner surface 470 of thrust ring 220a. As shown, each of axial ends 520-1 and 520-2 may include two recesses 530, which may extend from outer surface 465 to inner surface 470 to facilitate lubricating fluid flow between an exterior of thrust ring 220a and an interior of thrust ring 220a. Alternatively, axial ends 520-1 and 520-2 may include another number of recesses. For example, in some embodiments, axial end 520-1 may include a different number of recesses than axial end 520-2.

As shown in Figs. 7-9, inner surface 470 of thrust ring 220a may include three protrusions 540, all extending along a circumference of thrust ring 220a and toward a central axis of thrust ring 220a. Protrusions 540 may have approximately rectangular cross-sections 545, and may be offset, in an axial direction of thrust ring 220a, from a center of thrust ring 220a, as best shown in Fig. 9. Some embodiments, however, may include different configurations of protrusions. For example, some embodiments may have only one protrusion, which may or may not extend along an entire circumference of thrust ring 220a. Other embodiments may have a plurality of protrusions, but such protrusions may be shaped or positioned differently than protrusions 540. For example, instead of having approximately rectangular cross-sections, they may have approximately U-shaped or V-shaped protrusions, and they may or may not be offset from the center of thrust ring 220a.

Fig. 10 illustrates another embodiment of a track joint assembly 155' including a different bushing configuration. Instead of having inner bushing 157 and outer bushing 250, track joint assembly 155' may include only a single bushing 157'. Otherwise, track joint assembly 155' may be identical to track joint assembly 155.

Bushing 157' may be similar to bushing 157. Accordingly, only the ways in which bushing 157' differs from bushing 157 will be described. Bushing 157' may include a middle portion 570' between axial end-adjacent portions 340a', 340b'. Thus, middle portion 570' may be separated from axial end portions 320a', 320b' by axial end-adjacent portions 340a', 340b'. Middle

portion 570' may have an outer diameter 580' that is larger than outer diameters 360a', 360b' of end-adjacent portions 340a', 340b' to maximize the amount of wear that middle portion 570' may sustain as a result of engagement with the drive sprocket. For example, outer diameter 580' may be approximately 1.49  
 5 times outer diameters 360a', 360b'. It should be understood, however, that outer diameter 580' may be another size. For example, outer diameter 580' may be between approximately 1.25 and approximately 2.00 times outer diameters 360a', 360b'. In some embodiments, middle portion 570' may be positioned at least partially within inner portions 590a', 590b' of bushing bores 160a', 160b'.  
 10 In other embodiments, middle portion 570' may not be positioned at least partially within inner portions 590a', 590b'.

Fig. 11 illustrates yet another embodiment of track joint assembly 155'' including different bushing and link configurations. Like track joint assembly 155', instead of having inner bushing 157 and outer bushing 250, track joint assembly 155'' may include only a single bushing 157''. Additionally,  
 15 instead of having links 110a, 110b, track joint assembly 155'' may include links 110a'' and 110b''. Bushing 157'' may be similar to bushing 157', and links 110a'', 110b'' may be similar to links 110a', 110b' (and thus links 110a, 110b). Links 110a'', 110b'' may differ from links 110a', 110b' only in that they include  
 20 bushing bores 160a'', 160b'' having only two portions (outer portions 330a'', 330b'' and central portions 350a'', 350b'') instead of three portions (outer portions 330a', 330b', central portions 350a', 350b', and inner portions 590a', 590b'). And bushing 157'' may differ from bushing 157' only in that middle portion 570'' may not be positioned at least partially within inner portions of  
 25 bushing bores 160a'', 160b''. Otherwise, track joint assembly 155'' may be identical to track joint assemblies 155 and 155'.

The components of track joint assemblies 155, 155', 155'' may be constructed of various materials. In some embodiments, links 110a, 110b, 110a', 110b', 110a'', 110b''; bushings 157, 157', 157''; bushings 250; thrust  
 30 rings 220a, 220b; and thrust rings 290a, 290b may be constructed of metal. For example, each of these components may be constructed of a ferrous metal, such as steel or iron.

The configuration of track joint assemblies 155, 155', 155'' is not limited to the configurations discussed above and shown in the drawings. For

example, outer surface 210 of pin 120 may include recesses instead of inner surface 200 of bushing 157. Such recesses may be similar to recesses 440 in outer surface 280 of bushing 157. As another example, inner surface 270 of outer bushing 250 may include recesses instead of outer surface 280 of bushing 157. Such recesses may be similar to recesses 400 in inner surface 200 of bushing 157.

### Industrial Applicability

The disclosed track joint assemblies may be applicable to track-type machines, such as, for example, loaders, tractors, excavators, and tanks, and may facilitate movement of the machines. The disclosed track joint assemblies may have various advantages over prior art track joint assemblies. For example, the disclosed track joint assemblies may be stronger and more durable than prior art track joint assemblies. In addition, manufacturing the disclosed track joint assemblies may cost less than manufacturing prior art track joint assemblies, and may require less material than manufacturing prior art track joint assemblies. Specific advantages of the disclosed track joint assemblies will now be described.

Track joint assembly 155 may include direct connections between links 110a, 110b that strengthen and improve the durability of track joint assembly 155. Specifically, inwardly offset ends 140a, 140b of links 110a, 110b may be directly connected by being secured to bushing 157. Likewise, outwardly offset ends 150a, 150b of links 110a, 110b may be directly connected by being secured to pin 120. Such direct connections between links 110a, 110b may strengthen and improve the durability of track joint assembly 155 by reducing its susceptibility to vibrations and impacts.

Track joint assembly 155 may be configured to facilitate rotation of bushing 157 relative to pin 120 even when pin 120 is solid (and thus capable of being manufactured without using costly machining, drilling, or casting processes). In particular, the rotation may be facilitated by coating one or both of bushing 157 and pin 120 with diamond like carbon or electroless nickel, or by carburizing, nitriding, or polishing one or both of bushing 157 and pin 120 to reduce friction between bushing 157 and pin 120. Alternatively or additionally, the rotation may be facilitated by situating a lubricating fluid between bushing

157 and pin 120. Specifically, the lubricating fluid may be added through openings 180a, 180b in links 110a, 110b, and may be contained in lubricating fluid cavity 190. Since pin 120 is solid, rather than extending into an interior cavity of pin 120, lubricating fluid cavity 190 may extend into and be at least partially defined by one or more recesses in inner surface 200 of bushing 157 or outer surface 210 of pin 120. Alternatively or additionally, lubricating fluid cavity 190 may extend into and be at least partially defined by thrust rings 220a, 220b.

Track joint assembly 155 may be configured to minimize the total amount of material required to manufacture links 110a, 110b. Such minimization may be achieved by reducing the number of components disposed in bushing bores 160a, 160b of links 110a, 110b. For example, no collar or seal insert needs to be positioned between bushing bore 160a and bushing 157, because the material of sealing portion 485 of link 110a may resist wear and corrosion resulting from sealing portion 485's contact with seal assembly 240a. Thus, inwardly offset ends 140a of links 110a may be secured directly to bushing 157, minimizing the number of components disposed in bushing bore 160a and thus the size of bushing bore 160a and link 110a. For example, the diameter of central portion 350a of bushing bore 160a may be less than 1.49 times the diameter of pin bore 170a. Additionally, the diameter of central portion 350a of bushing bore 160a may be less than 0.87 times the outer diameter of outer bushing 250.

Track joint assemblies 155, 155' and 155'' may be optimized for specific applications but include many interchangeable parts to minimize manufacturing costs. For example, track joint assembly 155 may be optimized for high impact applications in which drive sprockets quickly wear down bushings connecting links 110a, 110b, while track joint assemblies 155' and 155'' may be optimized for low impact applications in which bushing wear is not a major concern. As discussed above, however, such optimizations only affect a few parts of track joint assemblies 155, 155', and 155''. Thus, virtually all of the parts of track joint assemblies 155, 155', and 155'' are interchangeable.

It will be apparent to those skilled in the art that various modifications and variations can be made to the disclosed track joint assemblies. Other embodiments will be apparent to those skilled in the art from

consideration of the specification and practice of the disclosed track joint assemblies. It is intended that the specification and examples be considered as exemplary only, with a true scope being indicated by the following claims and their equivalents.

CLAIMS:

1. A track joint assembly, comprising:
  - a first link having a first bore;
  - a second link having a second bore, the second bore including first and second bore
  - 5 portions, the first and second bore portions having different diameters;
  - a solid pin positioned at least partially within the first bore; and
  - a bushing positioned coaxially around the pin, and including:
    - an axial end portion disposed in and directly contacting the first bore portion of the
    - second bore; and
    - 10 an axial end-adjacent portion disposed in and directly contacting the second bore
    - portion of the second bore,
    - wherein an outer diameter of the end-adjacent portion is larger than an outer diameter
    - of the end portion.
2. The track joint assembly of claim 1, wherein: the bushing includes a middle portion
- 15 that is separated from the end portion by the end-adjacent portion; and an outer diameter of the
- middle portion is larger than the outer diameter of the end-adjacent portion.
3. The track joint assembly of claim 2, wherein: the second bore has a third bore
- portion; and the middle portion is positioned at least partially within the third bore portion.
4. The track joint assembly of claim 2, wherein the outer diameter of the middle portion
- 20 is between approximately 1.25 and approximately 2.00 times the outer diameter of the end portion.
5. The track joint assembly of claim 4, wherein the outer diameter of the middle portion
- is approximately 1.49 times the outer diameter of the end portion.

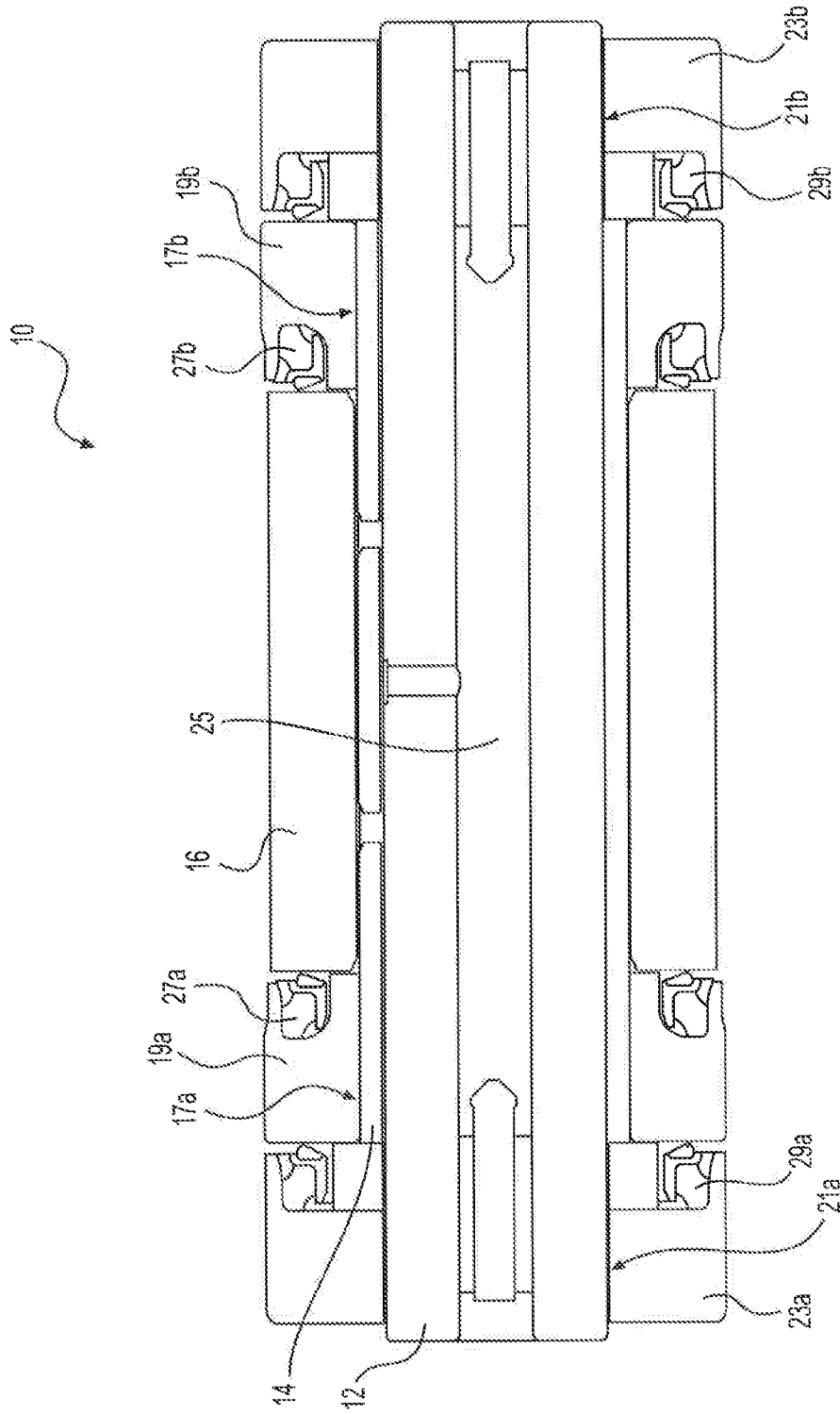
6. The track joint assembly of claim 1, including a thrust ring positioned at an axial end of the end portion.
7. The track joint assembly of claim 6, including a seal assembly positioned radially outward of the thrust ring, and contacting the second link.
- 5 8. The track joint assembly of claim 7, wherein the thrust ring has an outer diameter that is larger than the outer diameter of the end portion.
9. A track joint assembly, comprising:
- a first link having a first bore, the first bore including first and second bore portions, the first and second bore portions having different diameters;
- 10 a second link having a second bore; and
- a bushing including:
- a first axial end portion disposed in and directly contacting the first bore portion of the first bore;
- a first axial end-adjacent portion disposed in and directly contacting the second bore portion of the first bore; and
- 15 a second axial end portion disposed in and contacting the second bore,
- wherein an outer diameter of the first end-adjacent portion is larger than an outer diameter of the first axial end portion.
10. The track joint assembly of claim 9, wherein:
- 20 the bushing includes a middle portion between the first axial end-adjacent portion and the second axial end portion; and

an outer diameter of the middle portion is larger than the outer diameter of the first axial end-adjacent portion.

11. The track joint assembly of claim 10, wherein: the first bore has a third bore portion; and the middle portion is positioned at least partially within the third bore portion.
- 5 12. The track joint assembly of claim 10, wherein the outer diameter of the middle portion is between approximately 1.25 and approximately 2.00 times the outer diameter of the first axial end portion.
13. The track joint assembly of claim 12, wherein the outer diameter of the middle portion is approximately 1.49 times the outer diameter of the first axial end portion.
- 10 14. The track joint assembly of claim 9, including a thrust ring positioned at an axial end of the first axial end portion.
15. The track joint assembly of claim 14, including a seal assembly positioned radially outward of the thrust ring, and contacting the first link.
16. The track joint assembly of claim 15, wherein the thrust ring has an outer diameter  
15 that is larger than the outer diameter of the first axial end portion.
17. A track joint assembly, comprising:
- a first link having a first bore;
- a second link having a second bore; and
- a bushing including:
- 20 a first axial end portion directly contacting the first bore;
- a second axial end portion directly contacting the second bore; and
- a middle portion between the first and second axial end portions,

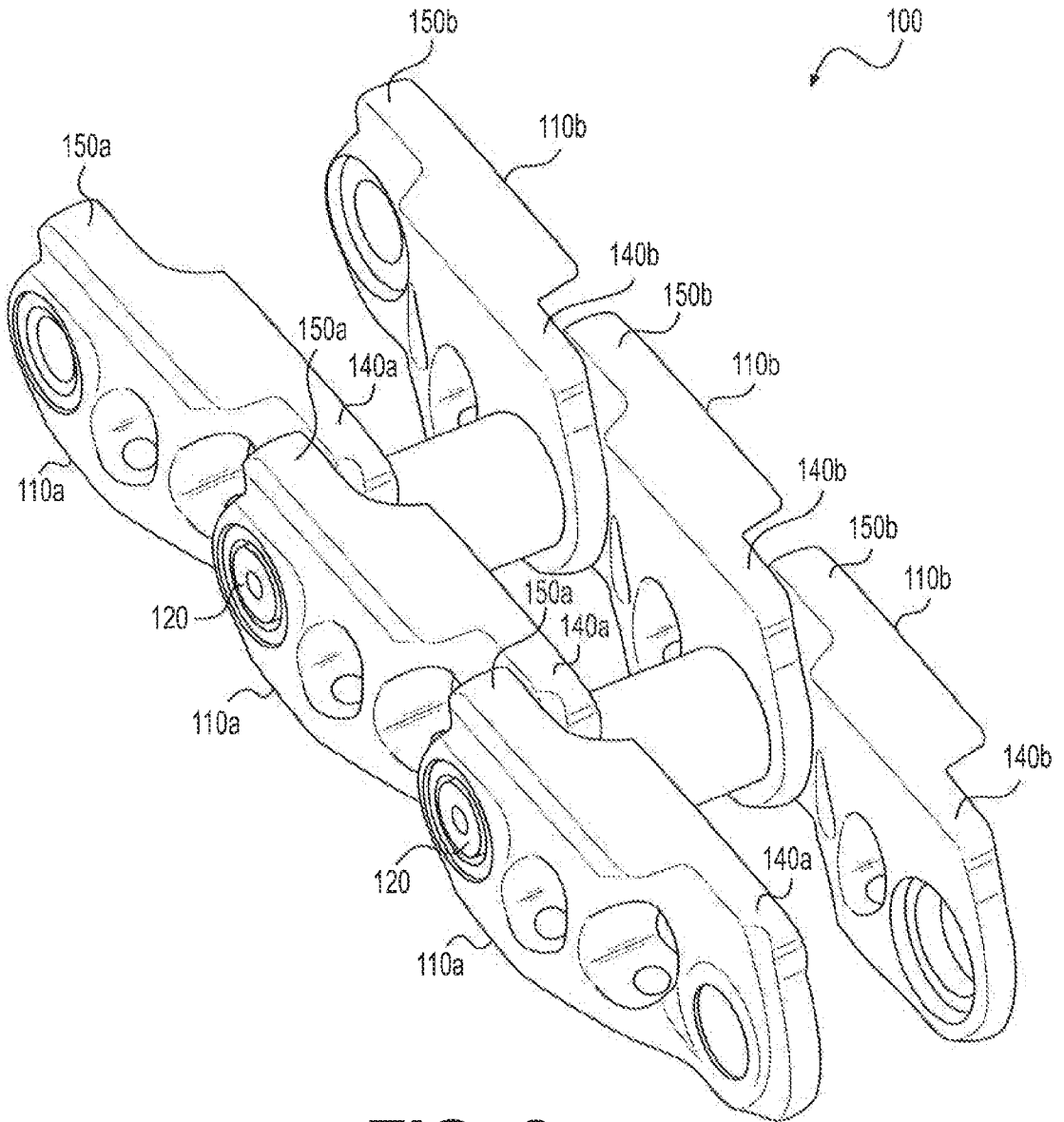
wherein the middle portion has an outer diameter greater than an outer diameter of the first and second axial end portions.

18. The track joint assembly of claim 17, wherein the middle portion is positioned at least partially within both the first and second bores and has an outer diameter that is between approximately 1.25 and approximately 2.00 times the outer diameter of the first and second axial end portions.
19. The track joint assembly of claim 17, wherein the outer diameter of the middle portion is approximately 1.49 times the outer diameter of the first axial end portion.
20. The track joint assembly of claim 17, including a thrust ring positioned at an axial end of the first axial end portion.
21. The track joint assembly of claim 20, including a seal assembly positioned radially outward of the thrust ring, and contacting the first link.
22. The track joint assembly of claim 21, wherein the thrust ring has an outer diameter that is larger than the outer diameter of the first axial end portion.

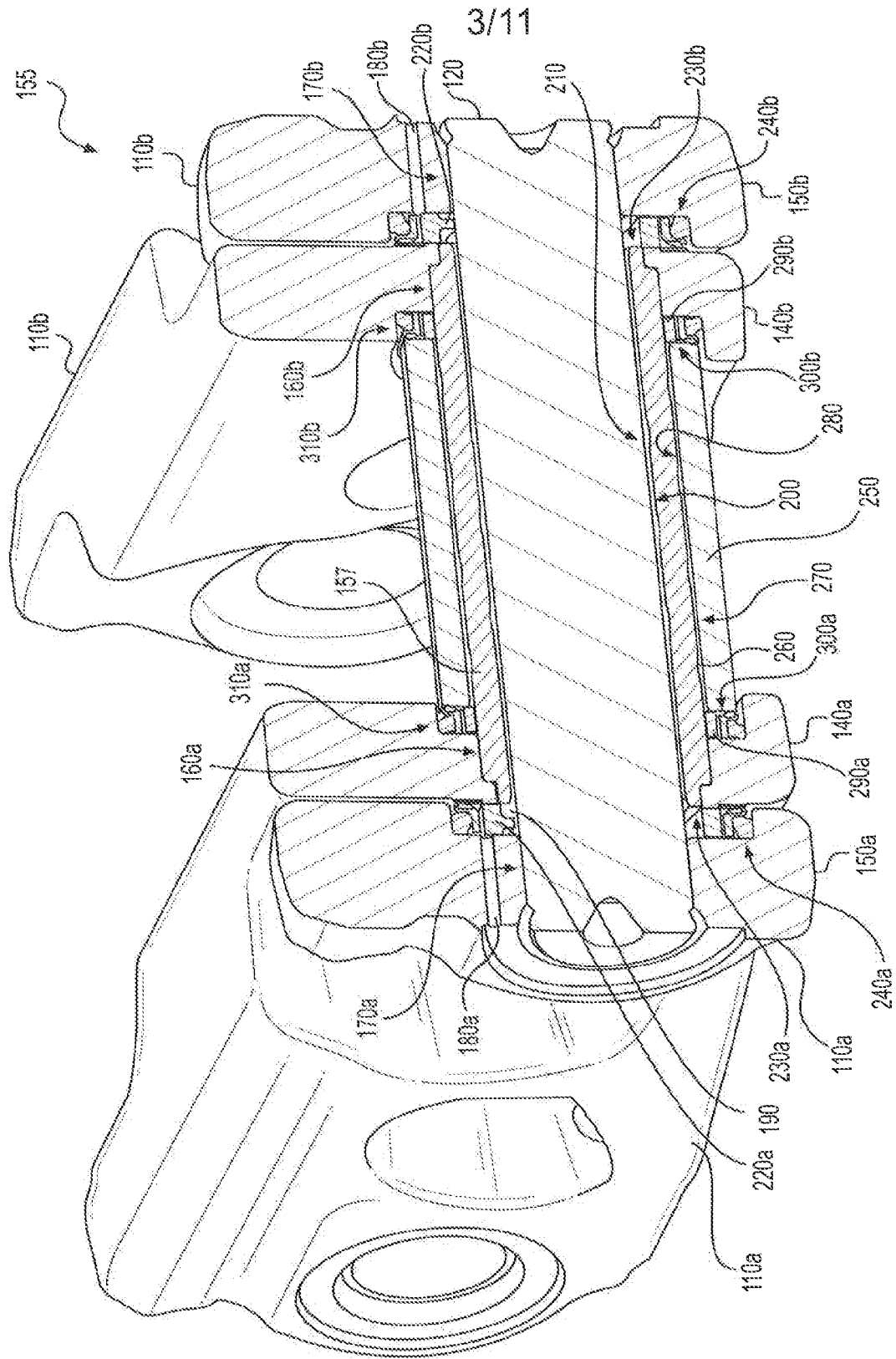


**FIG. 1**  
**Prior Art**

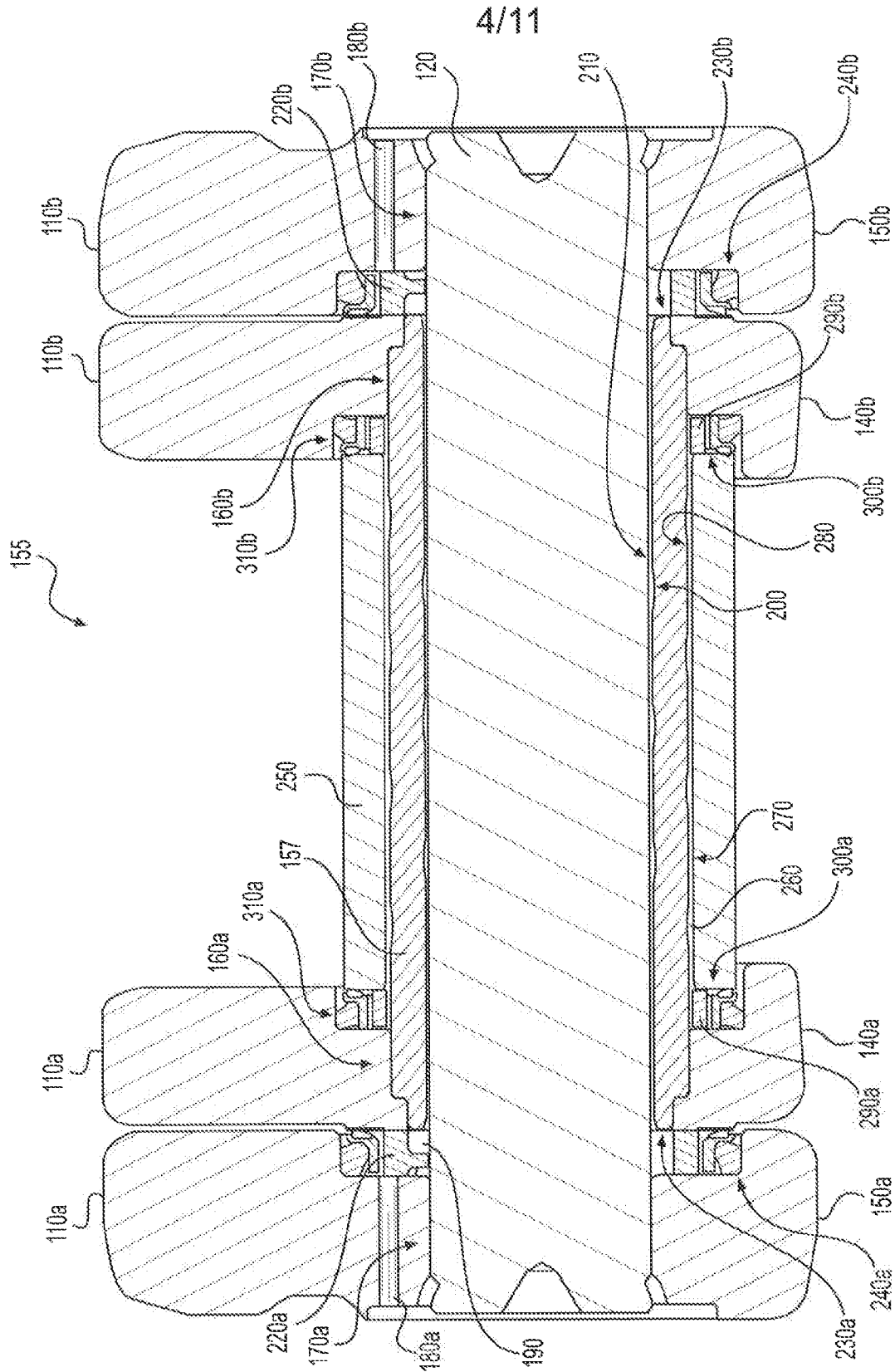
2/11



**FIG. 2**



**FIG. 3**



**FIG. 4**

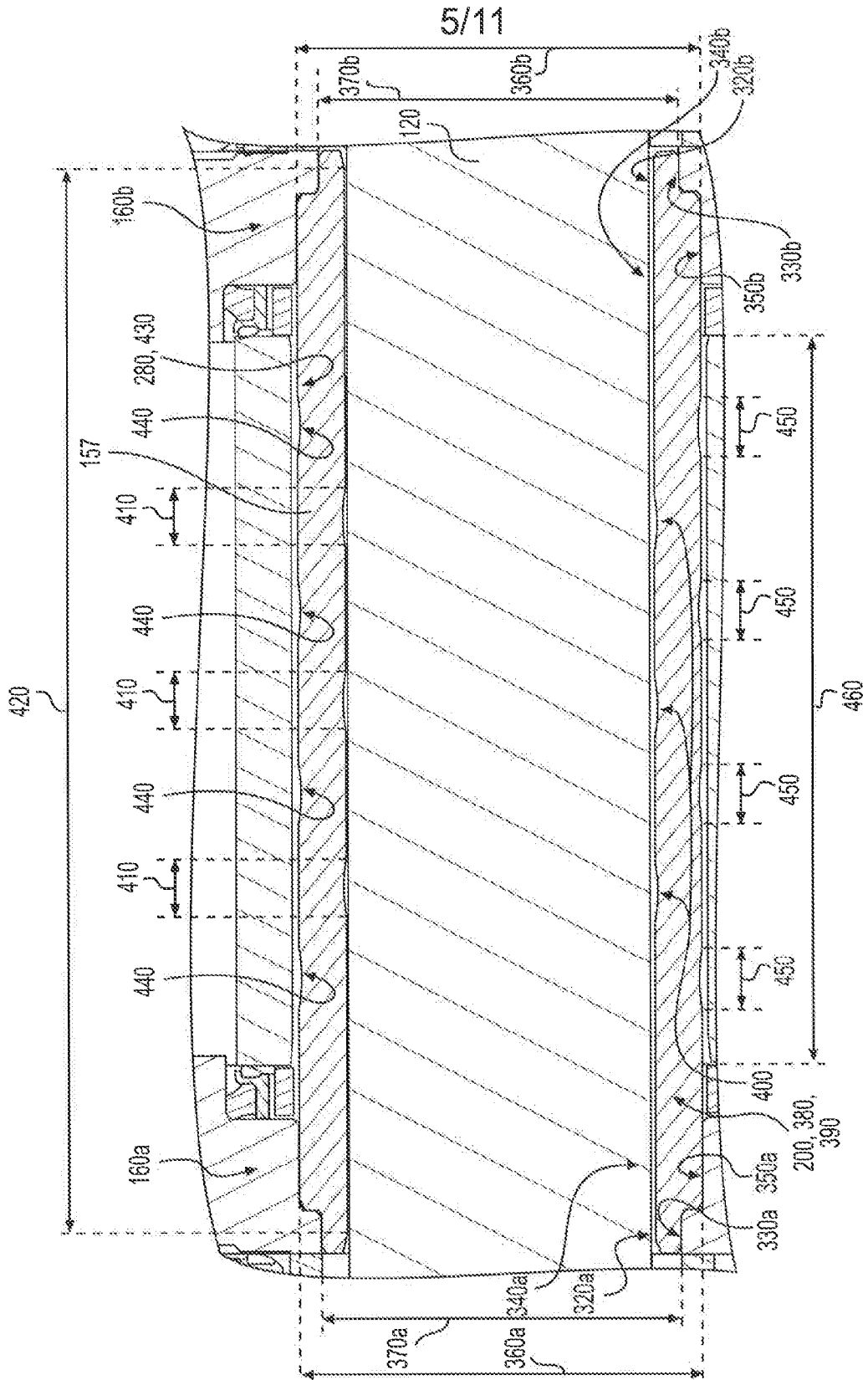
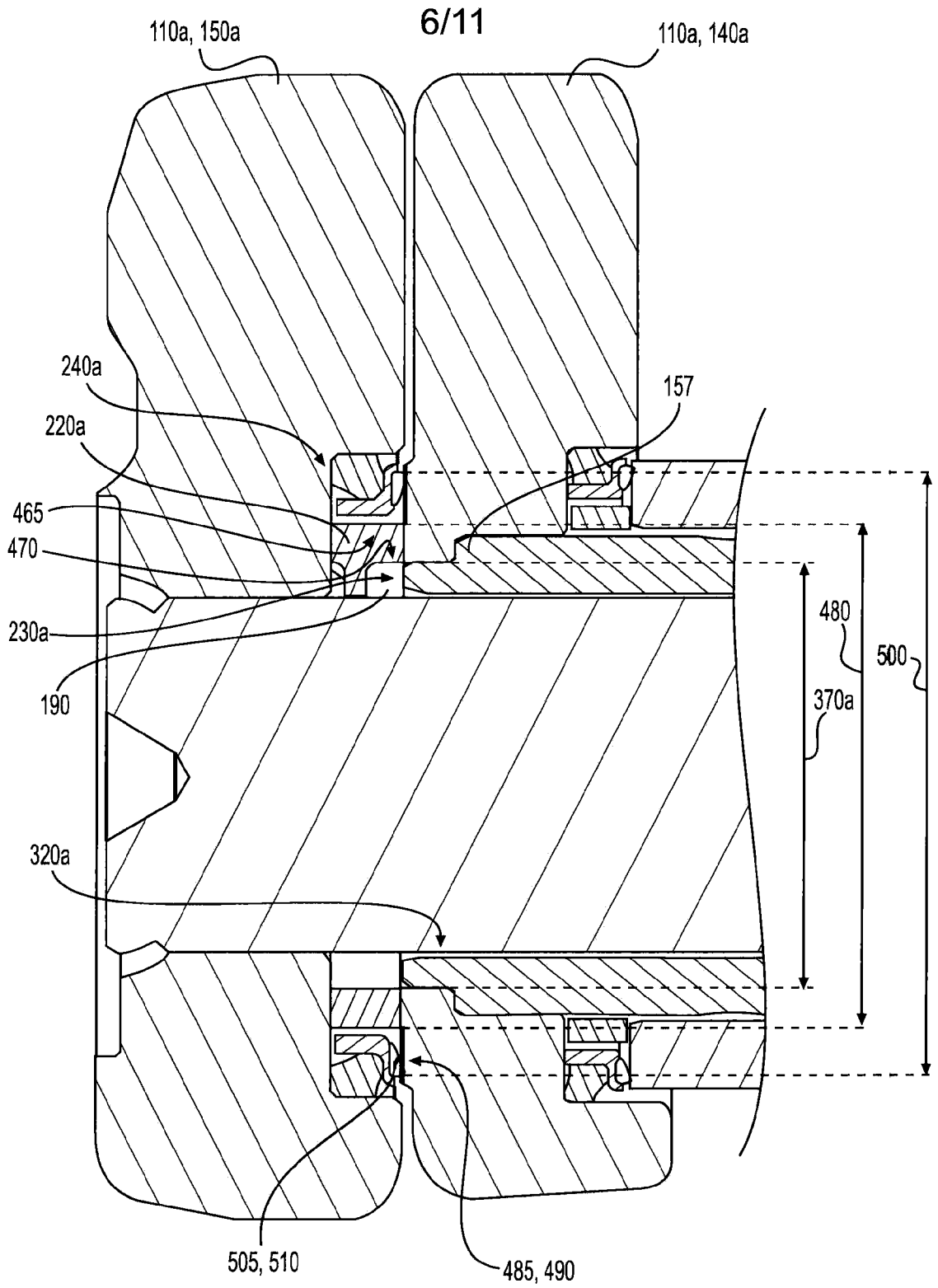
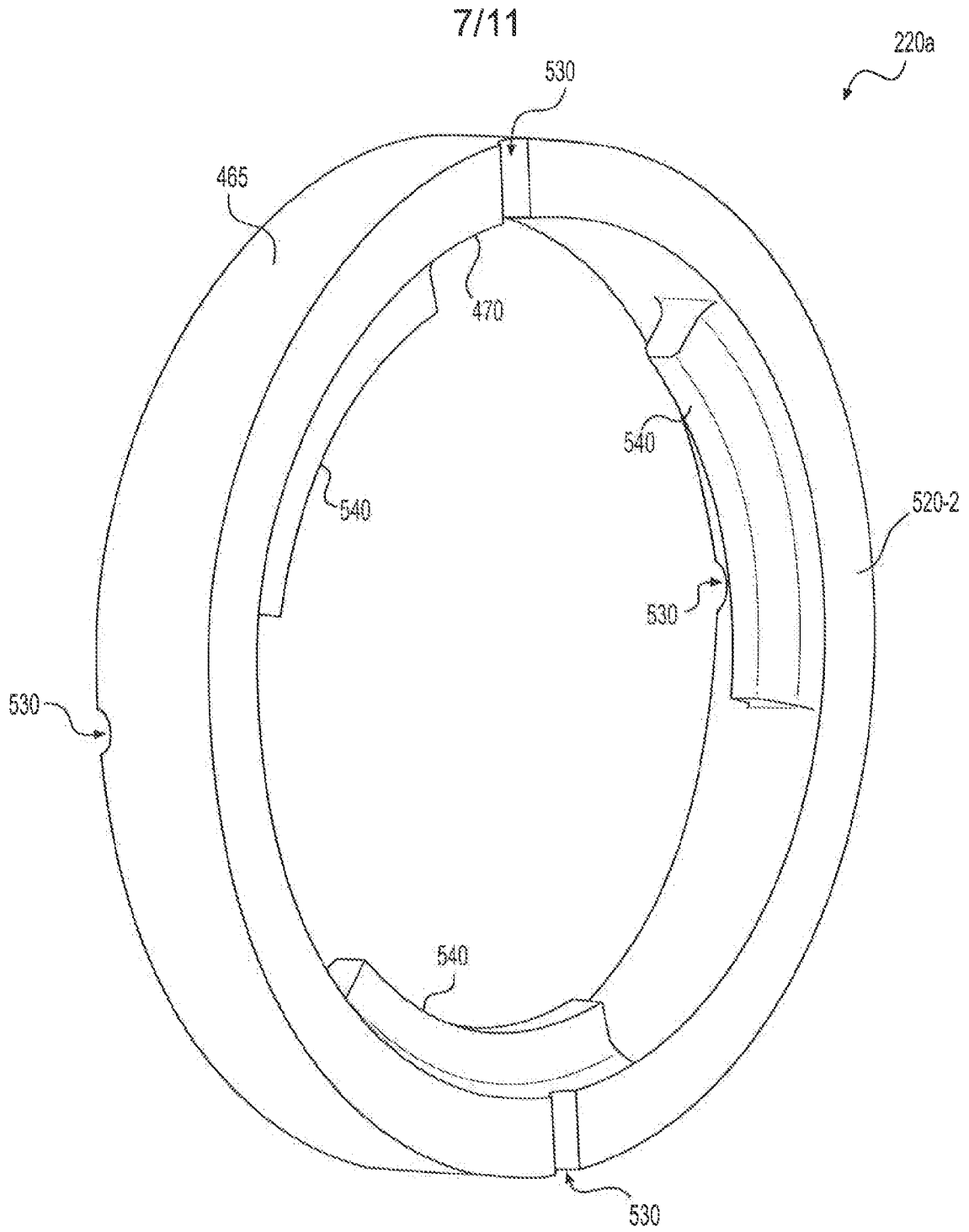


FIG. 5

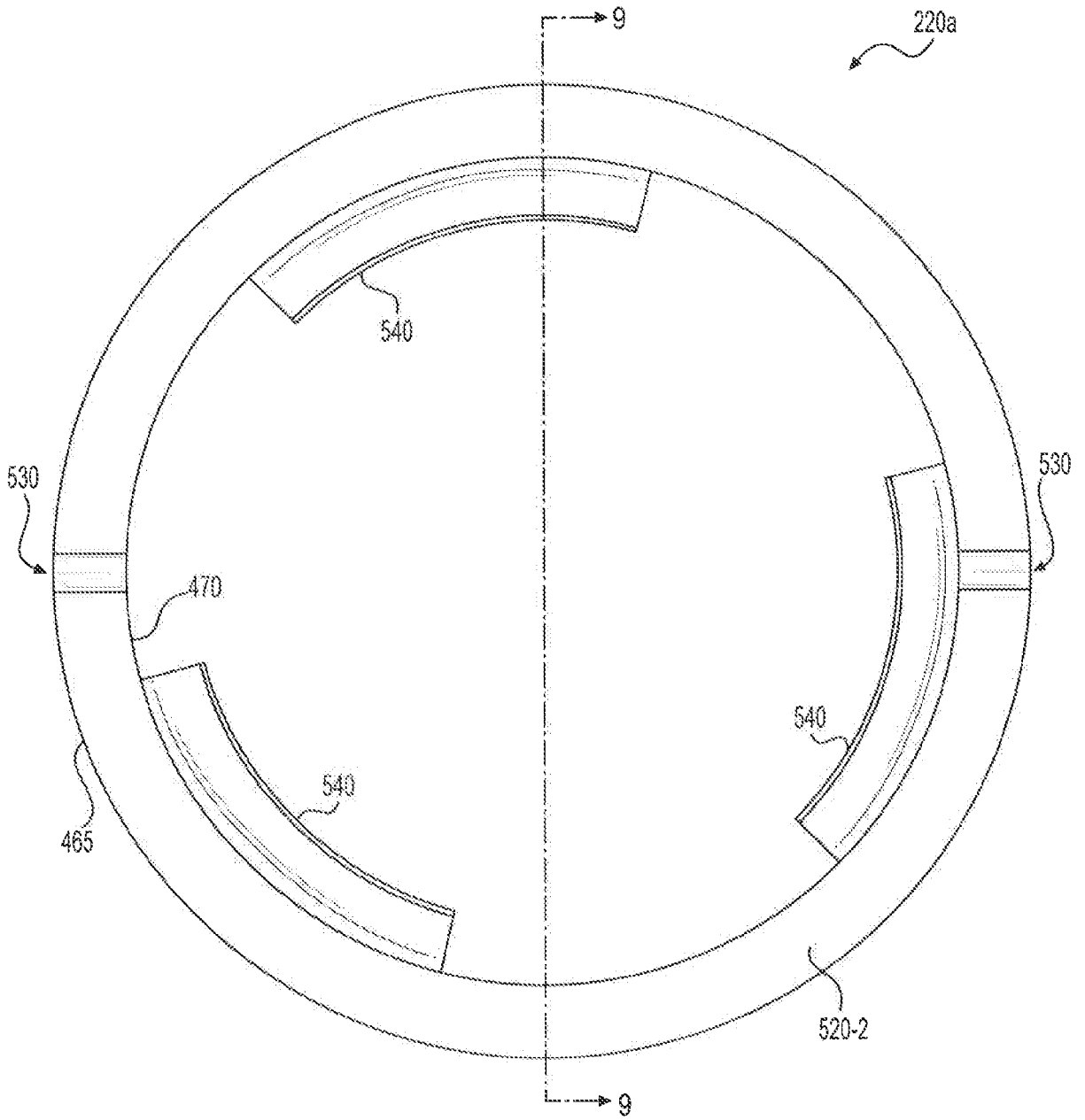


**FIG. 6**

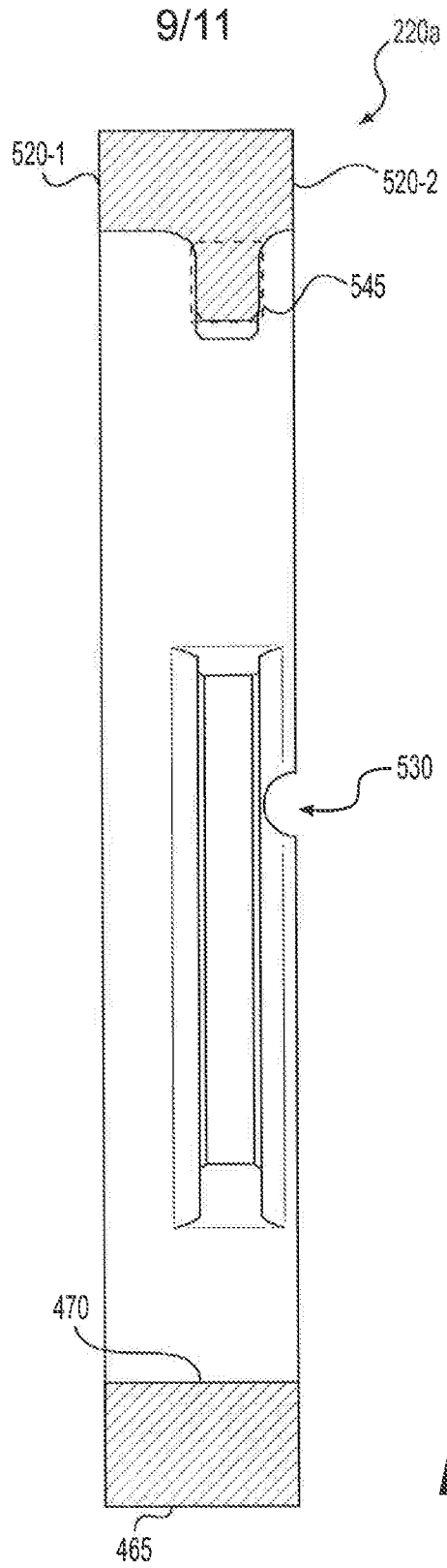


**FIG. 7**

8/11



**FIG. 8**



**FIG. 9**

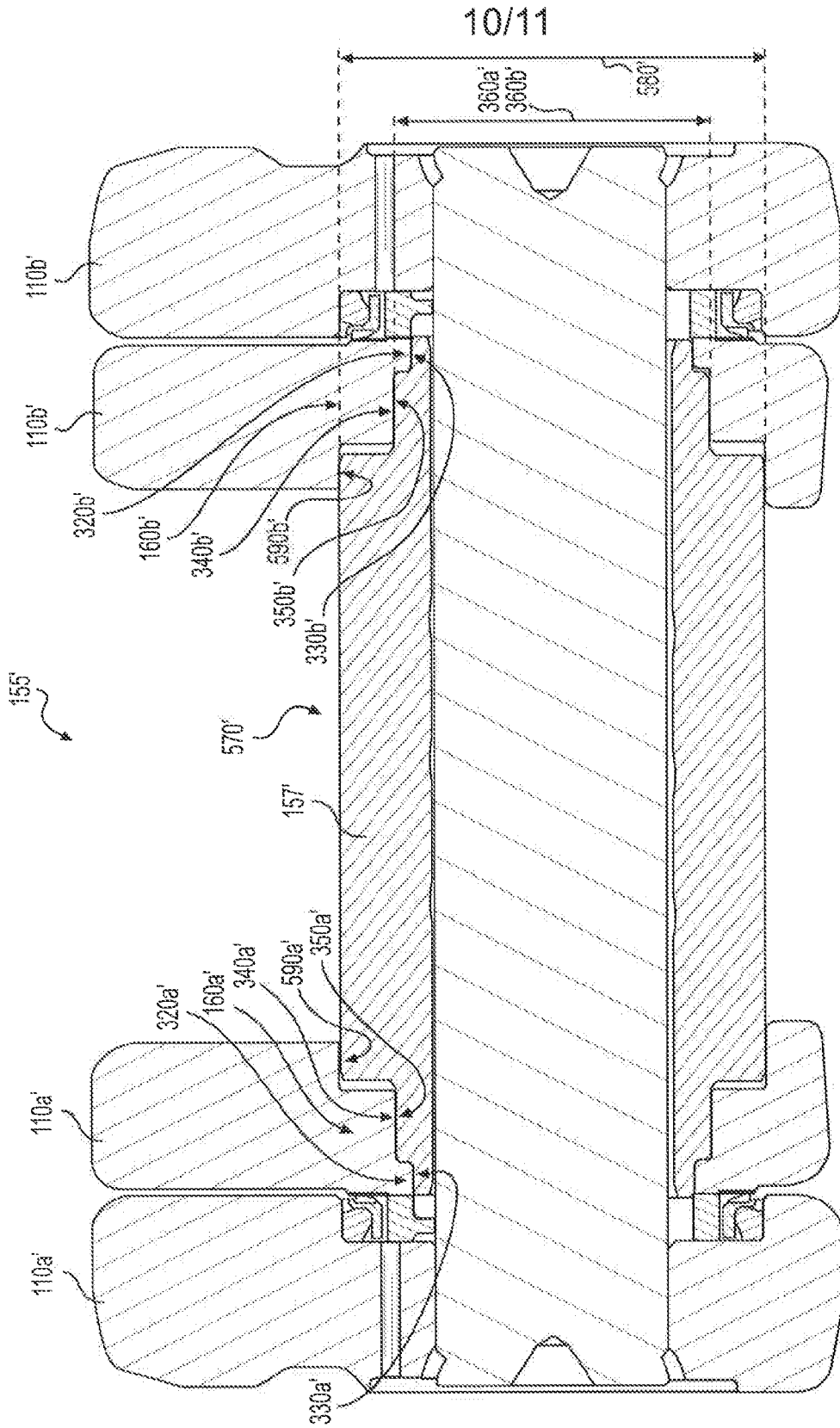
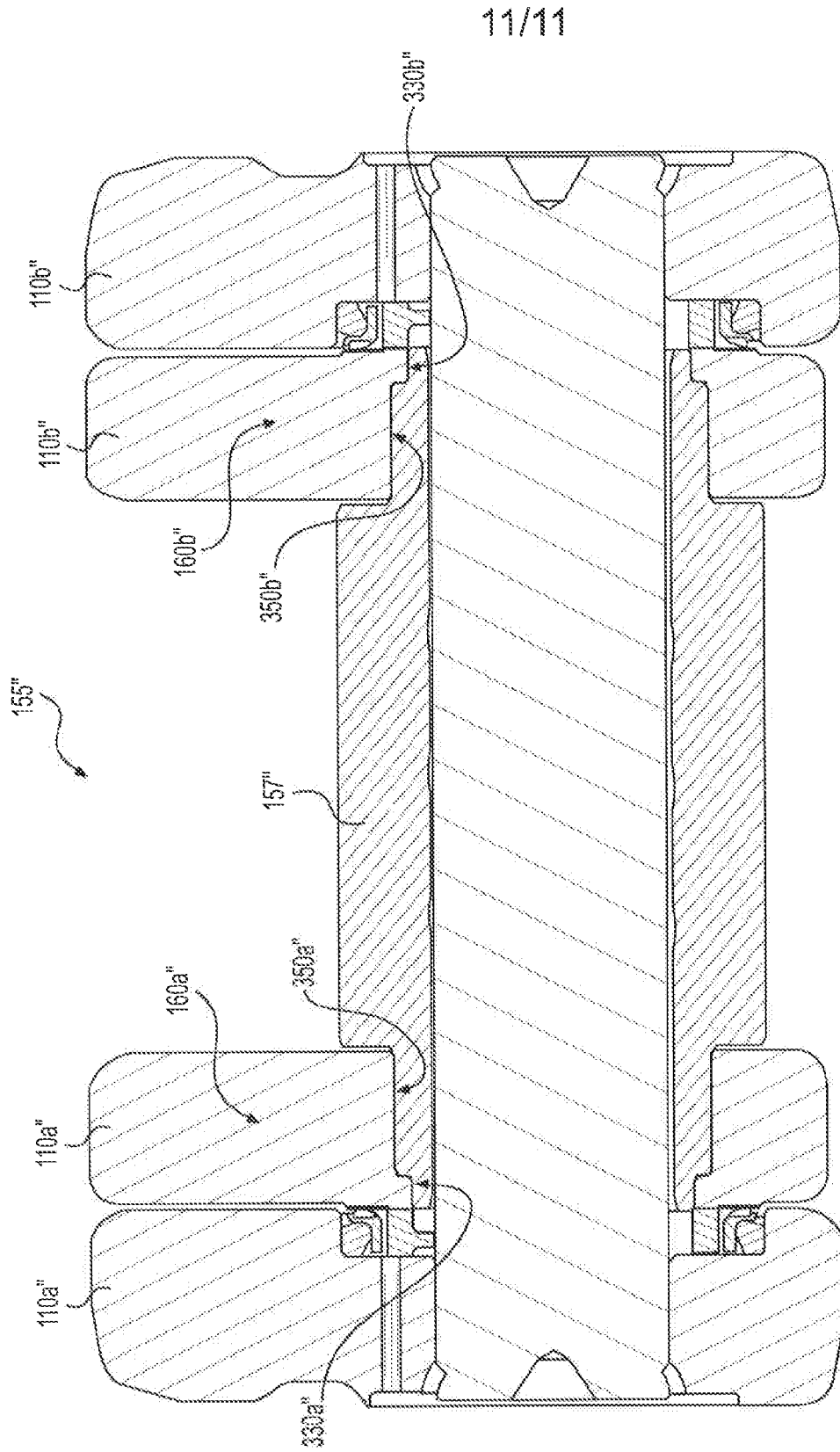


FIG. 10



**FIG. 11**

