

July 30, 1963

L. GOTTLIEB

3,099,201

FLOW-BOOSTING REGISTER FOR AIR DUCTS

Filed March 31, 1961

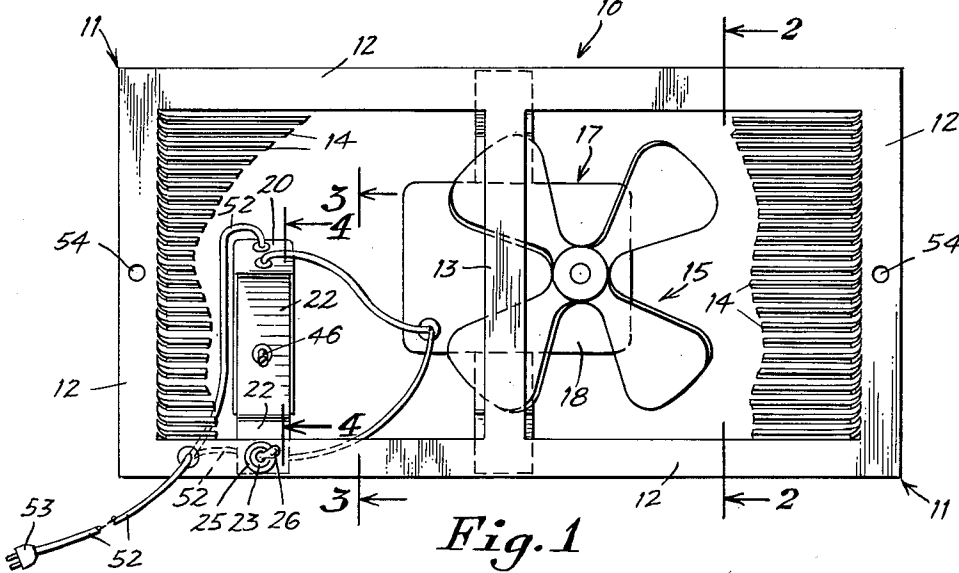

Fig. 1

Fig. 3

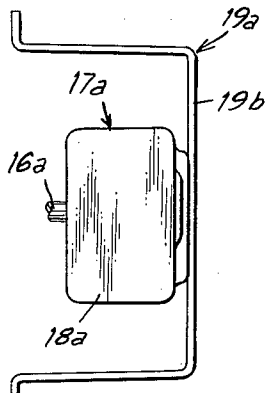
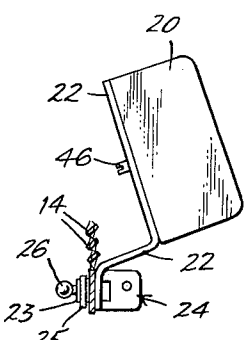

Fig. 5

Fig. 2

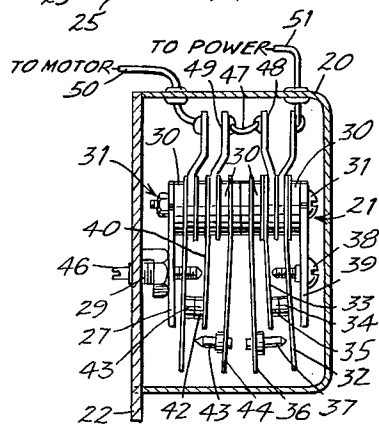
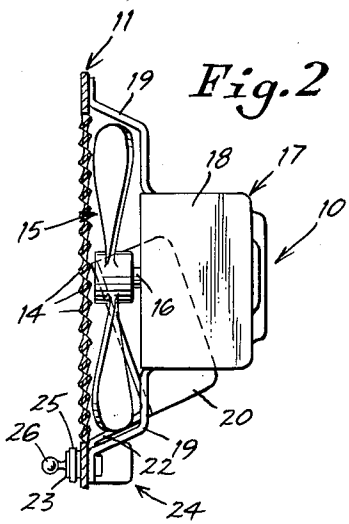

Fig. 4

INVENTOR
Leon Gottlieb,

BY Felix A. Russell

ATTORNEY

1

3,099,201

FLOW-BOOSTING REGISTER FOR AIR DUCTS

Leon Gottlieb, 7008 W. Park Drive, Hyattsville, Md.

Filed Mar. 31, 1961, Ser. No. 99,827

4 Claims. (Cl. 98-101)

This invention relates to a flow-boosting register for air ducts and it consists in the combinations, constructions and arrangements of parts herein described and claimed.

Generally there is provided a one piece louvered register grill of standard size and shape and formed of sheet metal or other suitable material. The register is interchangeable with conventional registers and requires only a screw driver for effecting the substitution. A small electric fan is mounted on the rear face of the register, as by the use of a U-shaped strap the bight portion of which is welded or otherwise fixed to the rear face of the motor housing. Alternatively, a pair of brackets welded to, or die-formed integrally with, the motor housing can be employed in place of the U-shaped strap. The free ends of the strap, or brackets, are welded or otherwise fixed to the margin of the grill.

A pair of thermostatic switches is also mounted on the rear surface of the grill, and is connected in series with each other and the fan motor. One switch is a normally closed safety switch that opens above 155° F. to break the circuit when such an abnormal temperature occurs (caused for example by a fire in or near the duct). The other switch is an adjustable control switch which automatically closes when the duct air reaches the temperature at which boosted circulation would be advantageous. A manual off-on switch and a flexible power cable and connected plug complete the unit.

It is accordingly a principal object of the invention to provide a fully automatic flow booster for the outlet of an air duct.

It is another object to provide such a device in the form of a standardized register grill having a fan and controls mounted thereon as a unit and easily interchangeable with a conventional register merely by use of a screw driver.

It is a further object to provide such a device with a safety thermal switch for stopping the motor if a dangerously high temperature occurs.

It is another object to provide a unitary device that is simple in construction, easy to install and maintain, economical to manufacture and yet highly efficient and effective in use.

Other and further objects of the invention will become apparent from a reading of the following specification taken in conjunction with the drawing, in which:

FIGURE 1 is a front elevational view, partly broken away, of a preferred embodiment of the invention,

FIGURE 2 is an end view of the showing of FIGURE 1 in section taken on the line 2—2 of FIGURE 1,

FIGURE 3 is a fragmentary side elevational view of the switch housing and its supporting structures, in section taken on line 3—3 of FIGURE 1,

FIGURE 4 is a rear elevational view of the switch assemblage, in section taken on line 4—4 of FIGURE 3, and

FIGURE 5 is a fragmentary side elevational view of the fan motor and its supporting U-shaped strap.

With reference now to the drawing, the numeral 10 generally designates the flow booster as a unit. Unit 10 comprises a die-formed, cast or molded grill 11 of sheet metal or sheet plastic, or cast or molded alloys, plastic, etc. Grill 11 has the usual imperforate marginal strip portions 12, with or without one or more medial trans-

2

verse strips 13, and integrally molded or cut and bent louvers 14.

A flow-accelerating propeller-type fan 15 is positioned behind a medial portion of the grill 11, being fixedly mounted on the shaft 16 of an induction motor 17. Motor 17 is encased in a housing 18 of sheet metal or equivalent material. Housing 18 has welded thereto (FIG. 2) or die-formed thereon, a pair of support arms located on diametrically opposite sides thereof and welded or otherwise fixed to the grill 11 at their free ends to support the motor and fan as shown in FIG. 2.

In the alternative construction illustrated in FIG. 5, the motor housing 18a is supported by a strap 19a bent into the shallow U-shape shown and welded at its out-turned ends to the margins of the grill (not shown). The bight portion 19b of strap 19a is welded or otherwise fixed to the rear wall of motor housing 18a.

A housing 20 for the thermostatic switch assemblage 21 is mounted on a bracket 22 welded or otherwise fixed to said housing 20. Bracket 22 may be attached to grill 11 by the hollow sleeve 23 of the manual switch 24 passing through aligned apertures in the grill 11 and the bracket 22 and held assembled therewith by the ring nut 25. The operating lever 26 of manual switch 24 extends outwardly from the front of the grill 11.

Switch assemblage 21 (FIG. 4) is mounted on a base plate 27 welded to nut 28. Nut 28 is clamped to the front wall of housing 20 by the threaded sleeve 29. The stacked spacing and insulating washers 30 and the hereinafter described spring arms and terminal elements are held in stacked assemblage by the nut and bolt 31 passing through aligned apertures in their base portions, in known manner.

The safety switch comprises a pair of spring arms 32 and 33 carrying mating contacts 34 and 35 and a bimetallic arm 36 carrying an insulating or insulated finger 37. Finger 37 lifts arm 32 to separate contacts 34 and 35 to open the motor energizing circuit when the temperature rises above the dangerous value (e.g., 155° F.) adjustable by the stop screw 38 carried by rigid arm 39.

The normal control thermostatic switch comprises the spring arms 40 and 41 carrying contacts 42 and 43 and the bimetallic arm 44 carrying insulated post 45. Arm 44 separates contacts 42 and 43 when the duct air drops below a temperature (e.g., 85° F.) selected by the adjusting screw 46 (FIGS. 1 and 4) accessible by a screw driver insertable between louvers in the grill 11. (For a cooling system, the switch 40-45 would open when the duct air temperature rises above a temperature of the order of 60° F.)

Switches 32-37 and 40-45 are connected in series by the jumper lead 47 joining their adjacent terminals 48 and 49 and the assemblage 21 is connected in series with one lead of the power input and manual switch 24 by the leads 50 and 51. The flexible cable 52 and its plug 53 complete the circuit to a conventional wall outlet (not shown).

To install the above described unit, the conventional grill (not shown) is removed by unscrewing the two screws that anchor it in place over the duct outlet opening. A booster unit of the same standardized size and shape is then placed over the duct outlet opening and fastened in place by the same two or like screws inserted into the standardly spaced apertures 54 (FIG. 1).

The plug 53 of cable 52 is then plugged into a wall outlet. Switch 24 is then closed or opened when and as desired. Adjusting screw 46 for the normal control thermostatic switch can be adjusted over a wide range to meet individual requirements.

While but two forms of the invention have been shown and described herein, it will be readily apparent to those

3

skilled in the art that many minor modifications may be made without departing from the spirit of the invention or the scope of the appended claims.

What is claimed is:

1. A flow-boosting register for an air duct outlet, comprising: a louvered grill of standard size and shape adapted for interchangeable use in place of a conventional register grill, a fan positioned behind said grill, a motor including a housing therefor and a shaft drivingly connected to and supporting said fan, strap-like means affixed to said housing and to opposite marginal portion of said grill for interconnecting said grill, fan and motor as a unit, and a plurality of control switches in series with said motor and a source of power for controlling the operation of said unit, at least one of said switches being a thermostatic switch for energizing said motor only when preselected temperatures occur in the air in said duct outlet, another of said switches being a manual switch including a casing positioned behind said grill, a threaded sleeve projecting forwardly through an aperture in said grill, a nut on said sleeve clamping said manual switch to said grill and a switch operator projecting through and

4

forwardly from said sleeve, a further one of said switches being a safety thermostatic switch set to interrupt the motor circuit when abnormally high temperatures occur in said duct outlet, said thermostatic switches being a unitary assemblage mounted within a protective housing.

2. Structure according to claim 1, said first thermostatic switch having an adjusting element projecting from said housing and positioned for adjusting access thereto by a screw driver insertable between certain louvers of said grill.

3. Structure according to claim 1, said strap-like means comprising a pair of bracket elements integrally joined at their ends to the motor housing.

4. Structure according to claim 3, said strap-like means being die-formed extensions of said motor housing.

References Cited in the file of this patent

UNITED STATES PATENTS

1,886,841	Searles	Nov. 8, 1932
2,972,941	Bennett	Feb. 28, 1961