



(43) International Publication Date
01 October 2020 (01.10.2020)

- (51) International Patent Classification:
E05B 3/08 (2006.01) *E05B 15/00* (2006.01)
- (21) International Application Number:
PCT/EP2020/058117
- (22) International Filing Date:
24 March 2020 (24.03.2020)
- (25) Filing Language: English
- (26) Publication Language: English
- (30) Priority Data:
102019000004641 28 March 2019 (28.03.2019) IT
- (71) Applicant: **OPENTECH S.R.L. A SOCIO UNICO**
[IT/IT]; Località Merlaro, 09, 25078 Nozza di Vestone
(Brescia) (IT).
- (72) Inventor: **LECLERCQ, Pascal**; Via Schia 2, 25017 Sede-
na di Lonato del Garda (Brescia) (IT).

- (74) Agent: **RAPISARDI, Mariacristina**; Via Serbelloni, 12,
20122 Milano (IT).
- (81) Designated States (*unless otherwise indicated, for every kind of national protection available*): AE, AG, AL, AM, AO, AT, AU, AZ, BA, BB, BG, BH, BN, BR, BW, BY, BZ, CA, CH, CL, CN, CO, CR, CU, CZ, DE, DJ, DK, DM, DO, DZ, EC, EE, EG, ES, FI, GB, GD, GE, GH, GM, GT, HN, HR, HU, ID, IL, IN, IR, IS, JO, JP, KE, KG, KH, KN, KP, KR, KW, KZ, LA, LC, LK, LR, LS, LU, LY, MA, MD, ME, MG, MK, MN, MW, MX, MY, MZ, NA, NG, NI, NO, NZ, OM, PA, PE, PG, PH, PL, PT, QA, RO, RS, RU, RW, SA, SC, SD, SE, SG, SK, SL, ST, SV, SY, TH, TJ, TM, TN, TR, TT, TZ, UA, UG, US, UZ, VC, VN, WS, ZA, ZM, ZW.
- (84) Designated States (*unless otherwise indicated, for every kind of regional protection available*): ARIPO (BW, GH, GM, KE, LR, LS, MW, MZ, NA, RW, SD, SL, ST, SZ, TZ, UG, ZM, ZW), Eurasian (AM, AZ, BY, KG, KZ, RU, TJ, TM), European (AL, AT, BE, BG, CH, CY, CZ, DE, DK, EE, ES, FI, FR, GB, GR, HR, HU, IE, IS, IT, LT, LU, LV,

(54) Title: SQUARE DRIVING PIN OF A LOCK OF A DOOR OR WINDOW

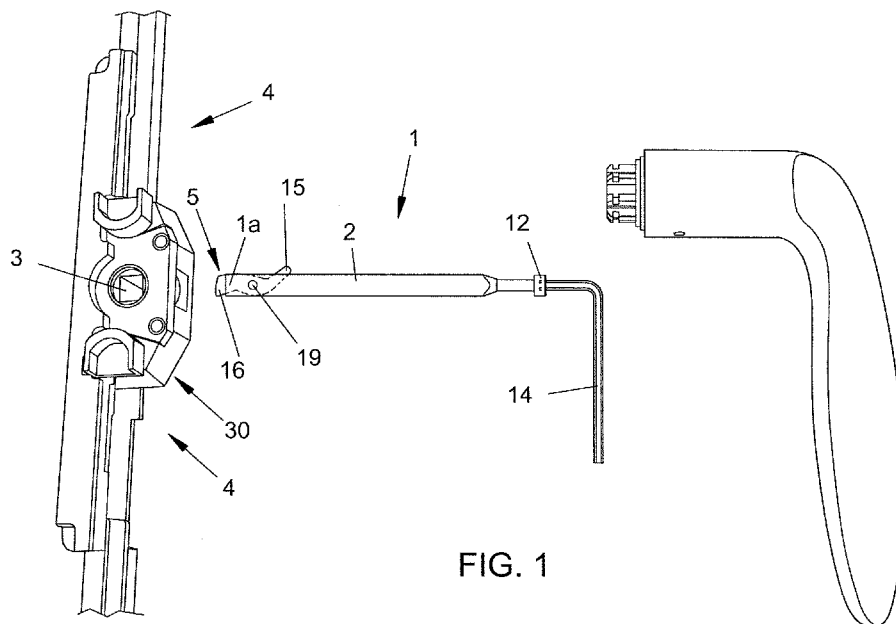

FIG. 1

(57) Abstract: The present invention describes a square driving pin (1) of a lock of a door or window comprising a longitudinal body (2) adapted to engage in a hole (3) of a control cam (30) of the mechanism of the lock (4) and a fixing anchor (5) for fixing said pin (1) to said hole (3), said longitudinal body (2) having at a first end (6) a housing (7) for said fixing anchor (5), said fixing anchor (5) being rotatable between a release position of said hole (3) in which it is retracted into said housing (7) and a fixing position (5) for fixing to said hole (3) in which it is protracted from said housing (7), characterised in that it further comprises a driving rod (8) of said fixing anchor (5) positioned in an axial cavity (9) of said longitudinal body (2).



WO 2020/193525 A1

MC, MK, MT, NL, NO, PL, PT, RO, RS, SE, SI, SK, SM,
TR), OAPI (BF, BJ, CF, CG, CI, CM, GA, GN, GQ, GW,
KM, ML, MR, NE, SN, TD, TG).

Declarations under Rule 4.17:

— *of inventorship (Rule 4.17(iv))*

Published:

— *with international search report (Art. 21(3))*

SQUARE DRIVING PIN OF A LOCK OF A DOOR OR WINDOW

DESCRIPTION

The present invention relates to a square driving pin of a lock of a door or window. The devices for opening and closing a door or window, as is known, usually have a lock with a deadbolt and/or latch control mechanism contained in a box recessed in the door or window, a handle and a square pin which connects the handle to the mechanism of the lock to transmit the rotation of the handle to a control cam of the mechanism.

To allow the correct operation of the lock, the square pin must be precisely and stably fixed in a hole of the control cam of the mechanism of the lock.

For the fixing of the square pin, one of its ends is provided with a rotatable fixing anchor for fixing to said hole and an oblique channel for inserting a driving screw of the fixing anchor.

After inserting the end of the square pin inside the hole, the installer inserts the screw by means of the use of a tool, such as a screwdriver or an Allen wrench.

In order to perform the fixing of the square pin it is necessary to create an access opening to the mechanism of the lock on the lateral surface of the door or window.

This access opening is then covered by a cover plate applied before fixing the handle to the square pin.

Since the direction of introduction of the screw is inclined with respect to the axial direction of the square pin, this access opening must be fairly wide in order to perform the operation.

An access opening of this size requires an equally wide cover plate.

A lock of this type greatly limits design choices because, for example, a cover

plate with a reduced size that would leave the access hole uncovered can never be installed.

The technical task addressed by the present invention is accordingly to realise a square driving pin of a lock of a door or window that enables the decried technical drawbacks of the prior art to be eliminated.

Within this technical task, one object of the invention is to realise a square driving pin of a lock of a door or window which is adaptable in a versatile manner for installation on doors or windows of various type.

Another object of the invention is to realise a square driving pin of a lock of a door or window that can be installed extremely easily, rapidly and precisely.

Another object of the invention is to realise a square driving pin of a lock of a door or window that guarantees the necessary fixing stability and a correct operation of the lock.

The technical task, as well as these and other objects, according to the present invention are achieved by realising a square driving pin of a lock of a door or window comprising a longitudinal body adapted to engage in a hole of a control cam of the mechanism of the lock and a fixing anchor for fixing said pin to said hole, said longitudinal body having at a first end a housing for said fixing anchor, said fixing anchor being rotatable between a release position of said hole in which it is retracted into said housing and a fixing position for fixing to said hole in which it is protracted from said housing, characterised in that it further comprises a driving rod of said fixing anchor positioned in an axial cavity of said longitudinal body.

Preferably, the rod has a thread engaged in a counter-thread of the axial cavity.

Preferably, the rod has a head positioned outside a second end of said longitudinal body, said head having a mark for engaging a driving tool of the rod.

Advantageously, the axial cavity leads into the housing to engage the rod with the fixing anchor.

Preferably, the anchor has a first and a second coupling tooth on opposite sides of said hole.

In particular, the pin comprises a hinge axis for hinging the fixing anchor on the longitudinal body, the first and second coupling teeth are positioned opposite said hinge axis.

Preferably, said anchor has a gripping cam of the movement from said rod.

Preferably, the housing is formed by an axial slot of the longitudinal body that extends as far as said first end.

Preferably, the first and the second tooth interfere with stop walls provided in said longitudinal body to limit the rotation of said fixing anchor.

The invention finally discloses a lock which comprises a square pin corresponding to that which is described above.

Further characteristics and advantages of the present invention will more fully emerge from the description of the square driving pin of a lock of a door or window according to the invention, illustrated by way of non-limiting example in the accompanying drawings, in which:

figure 1 shows an exploded perspective view of the square driving pin according to the present invention;

figure 2 shows an exploded perspective view of the square pin of figure 1 completely disassembled;

figure 3 shows a perspective view of the square pin of figure 2 completely assembled;

figure 4 and figure 5 show a section view of the square driving pin according to the present invention;

figure 6 shows a detail of the pin of figure 1 after its installation in the square hole of a lock.

With reference to the figures cited, a square driving pin of a lock of a door or window is shown, indicated in its entirety by reference number 1.

The pin 1 comprises a longitudinal body 2 adapted to engage in a hole 3 of a control cam 30 of the mechanism of the lock 4, and a fixing anchor 5 for fixing to the hole 3.

In particular, a first end 6 of the longitudinal body 2 intended to engage in the hole 3 has a housing 7 for the fixing anchor 5.

The fixing anchor 5 is rotatable between a release position of the hole 3 in which it is retracted into the housing 7 and a fixing position for fixing to the hole 3 in which it is protracted from the housing 7. Advantageously, the pin 1 further comprises a driving rod 8 of the fixing anchor 5 positioned in an axial cavity 9 of the longitudinal body 2.

The driving rod 8 has a thread 10 which engages in a counter-thread 11 present in the axial cavity 9.

The rod 8 has a head 12 positioned outside a second end 13 of the longitudinal body 2.

The head 12 has a mark 26 for engaging a driving tool 14 of the rod 8.

The driving rod 8 can be for example, but not limited to, a screw having a head and

a threaded stem.

Advantageously, the axial cavity 9 leads into the housing 7, realised in the first end 6 of the longitudinal body 2, for engaging the rod 8 with the fixing anchor 5.

The housing 7 is formed by an axial slot 27 of the longitudinal body 2 which extends from an intermediate position to the first end 6 of the longitudinal body 2.

The slot 27 extends linearly through two opposite sides 1a, 1b of the longitudinal body 2 and has a first end portion 24 on one side 1a and a second end portion 25 on the other side 1b of the two opposite sides 1a, 1b of the longitudinal body 2.

The two end portions 24, 25 are positioned at different axial distances from the first end 6 of the longitudinal body 2.

The fixing anchor 5 has a first 15 and a second 16 coupling tooth which are positioned on opposite sides 17, 18 of the hole 3.

The hinge axis 19 of the anchor 5 on the longitudinal body 2 is positioned transversely with respect to the axis of extension of the longitudinal body 2, in particular at the slot 27.

The first and the second coupling tooth 15, 16 are positioned opposite the hinge axis 19.

The first and the second coupling tooth 15, 16 interfere with a first stop wall 21 and a second stop wall 22 provided in the longitudinal body 2 that limit the rotation of the fixing anchor 5.

The fixing anchor 5 advantageously has a gripping cam 20 of the movement from the rod 8.

The method for installing the square pin 1 inside the hole 3 of the lock according to the present invention is described below.

After inserting the first end 6 of the longitudinal body 2 in the hole 3, the installer screws the rod 8 which, advancing through the cavity 9 towards the first end 6 of the longitudinal body 2, goes to engage the cam 20.

The rod 8 thus engages the cam 20, as illustrated in figure 4 and 5, rotating the fixing anchor 5 from the initial release position to the fixing position to the hole 3.

As is also seen in the figures, in the fixing position the anchor 5 is protracted from the housing 7 and its first 15 and second 16 coupling teeth engage the opposite sides 17, 18 of the hole 3.

In this configuration, the square pin 1 is stably fixed to the hole 3.

The fixing anchor 5 is never completely insertable into the housing 7 thanks to the presence of a first stop wall 21 of the longitudinal body 2 against which the first coupling tooth 15 abuts and a second stop wall 22 of the longitudinal body 2 against which the second coupling tooth 16 abuts.

The first wall 21 and the second wall 22 correspond to the end portions 24, 25 of the slot 27.

It must be noted that thanks to the provision of an axial housing for the control rod in the longitudinal body of the square pin, the access hole can have a smaller size because the installer operates in axis with the square pin.

Consequently, the cover plate of the access hole can be chosen with the maximum freedom, with the desired shape and size.

The square pin as conceived herein is susceptible to numerous modifications and variants, all falling within the scope of the inventive concept; furthermore, all the details are replaceable by technically equivalent elements.

In practice the materials used, as well as the size, can be any according to the needs

and the state of the art.

CLAIMS

1. A square driving pin (1) of a lock of a door or window comprising a longitudinal body (2) adapted to engage in a hole (3) of a control cam (30) of the mechanism of said lock (4) and a fixing anchor (5) for fixing said pin (1) to said hole (3), said longitudinal body (2) having at a first end (6) a housing (7) for said fixing anchor (5), said fixing anchor (5) being rotatable between a release position of said hole (3) in which it is retracted into said housing (7) and a fixing position (5) for fixing to said hole (3) in which it is protruded from said housing (7), characterised in that it further comprises a driving rod (8) of said fixing anchor (5) positioned in an axial cavity (9) of said longitudinal body (2).
2. The square driving pin (1) of a lock of a door or window according to the preceding claim characterised in that said rod (8) has a thread (10) engaged in a counter-thread (11) of said axial cavity (9).
3. The square driving pin (1) of a lock of a door or window according to the preceding claim characterised in that said rod (8) has a head (12) positioned outside a second end (13) of said longitudinal body (2), said head (12) having a mark (26) for engaging a driving tool (14) of said rod (8).
4. The square driving pin (1) of a lock of a door or window according to any preceding claim characterised in that said axial cavity (9) leads into said housing (7) to engage said rod (8) with said fixing anchor (5).
5. The square driving pin (1) of a lock of a door or window according to any preceding claim characterised in that said anchor (5) has a first (15) and a second (16) coupling tooth on opposite sides (17, 18) of said hole (3).

6. The square driving pin (1) of a lock of a door or window according to the preceding claim, characterised in that it comprises a hinge axis (19) for hinging said fixing anchor (5) on said longitudinal body (2), and in that said first (15) and second (16) coupling teeth are positioned opposite said hinge axis (19).
7. The square driving pin (1) of a lock of a door or window according to any preceding claim, characterised in that said anchor (5) has a gripping cam (20) of the movement from said rod (8).
8. The square driving pin (1) of a lock of a door or window according to any preceding claim characterised in that said housing (7) is formed by an axial slot (27) of said longitudinal body that extends as far as said first end (6).
9. The square driving pin (1) of a lock of a door or window according to any preceding claim, characterised in that said first (15) and second (16) coupling tooth interfere with stop walls (21, 22) provided in said longitudinal body (2) to limit the rotation of said fixing anchor (5).
10. A lock characterised in that it comprises a square pin conforming to any preceding claim.

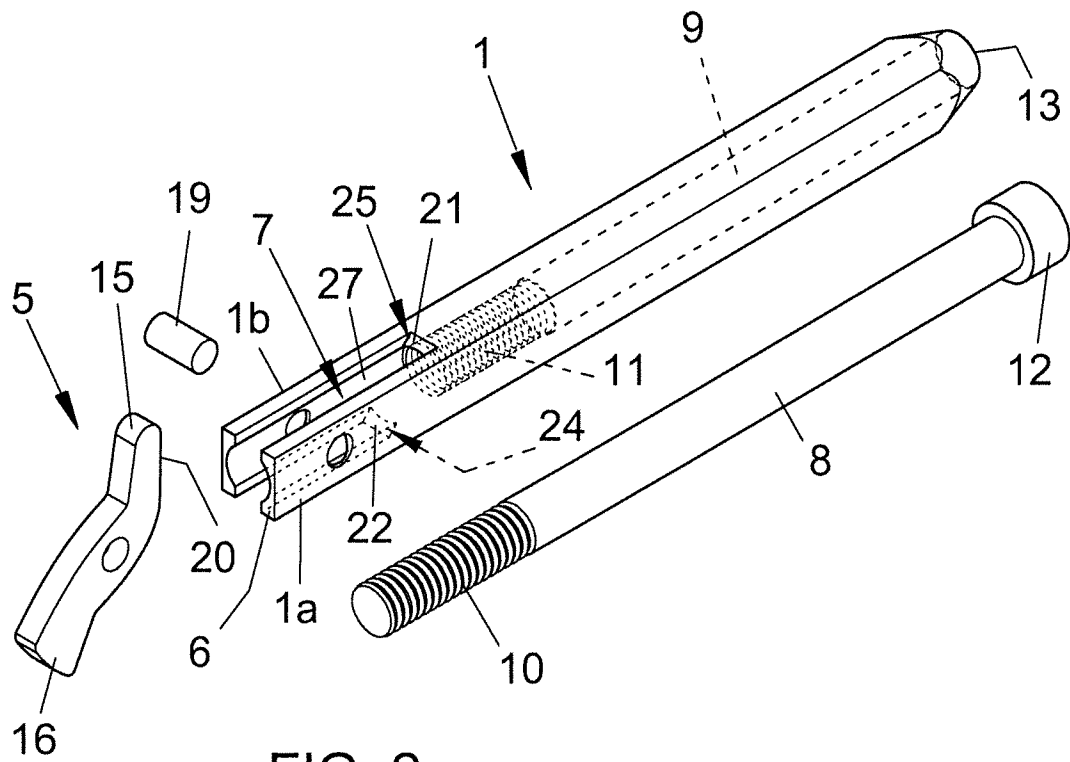

FIG. 2

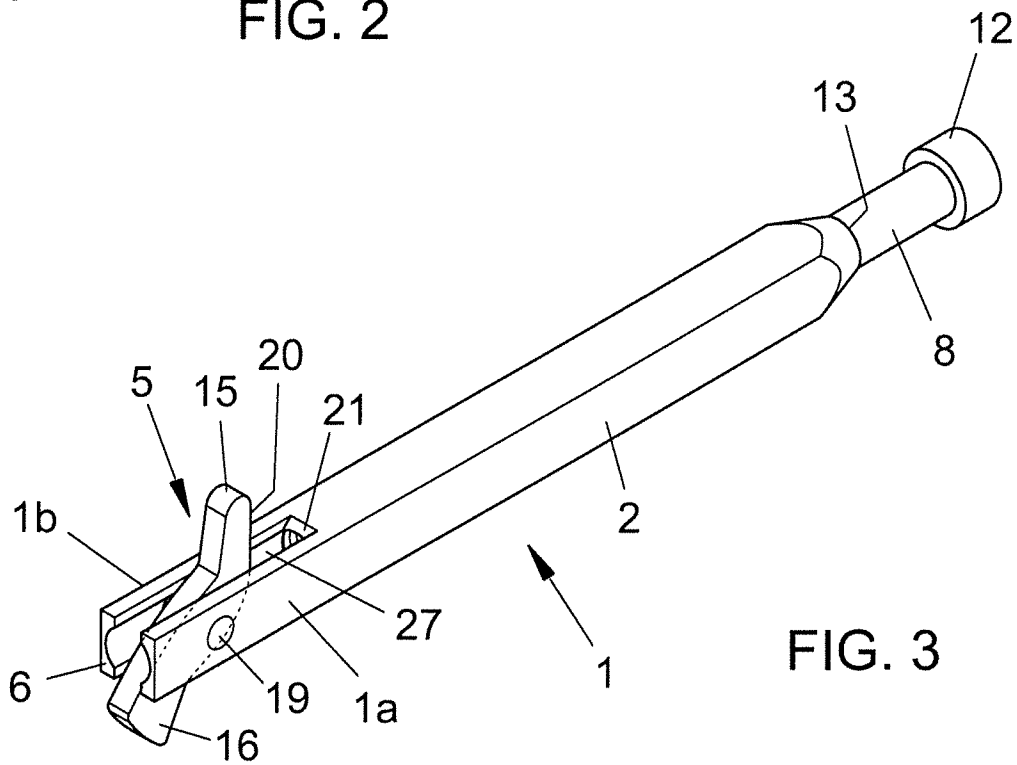

FIG. 3

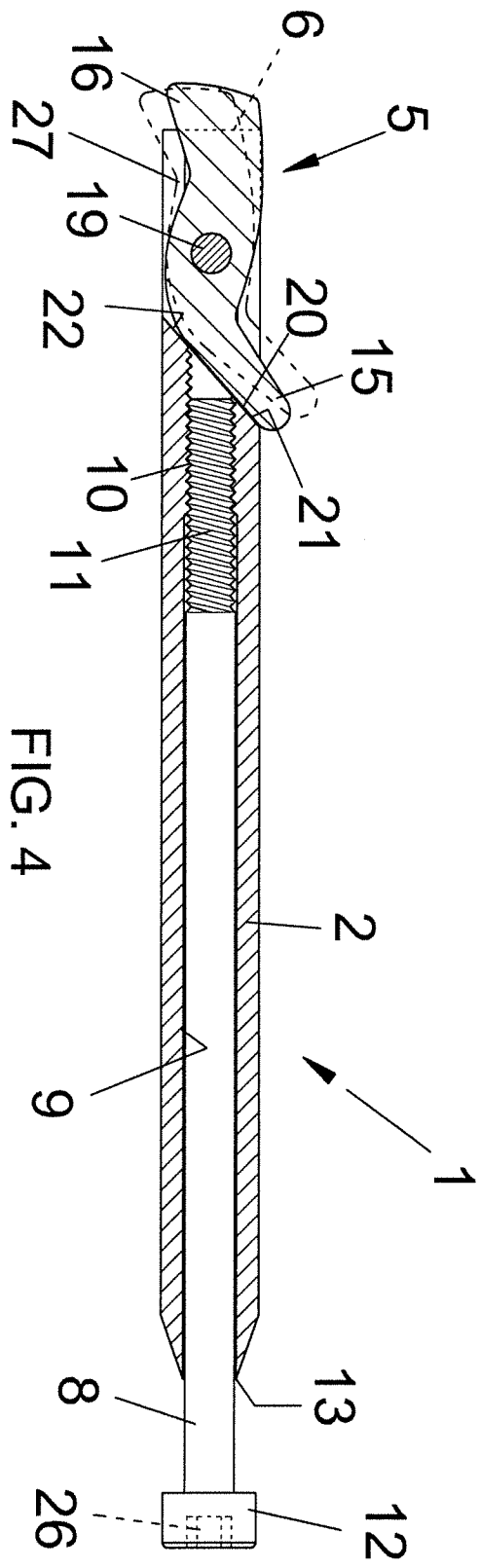

FIG. 4

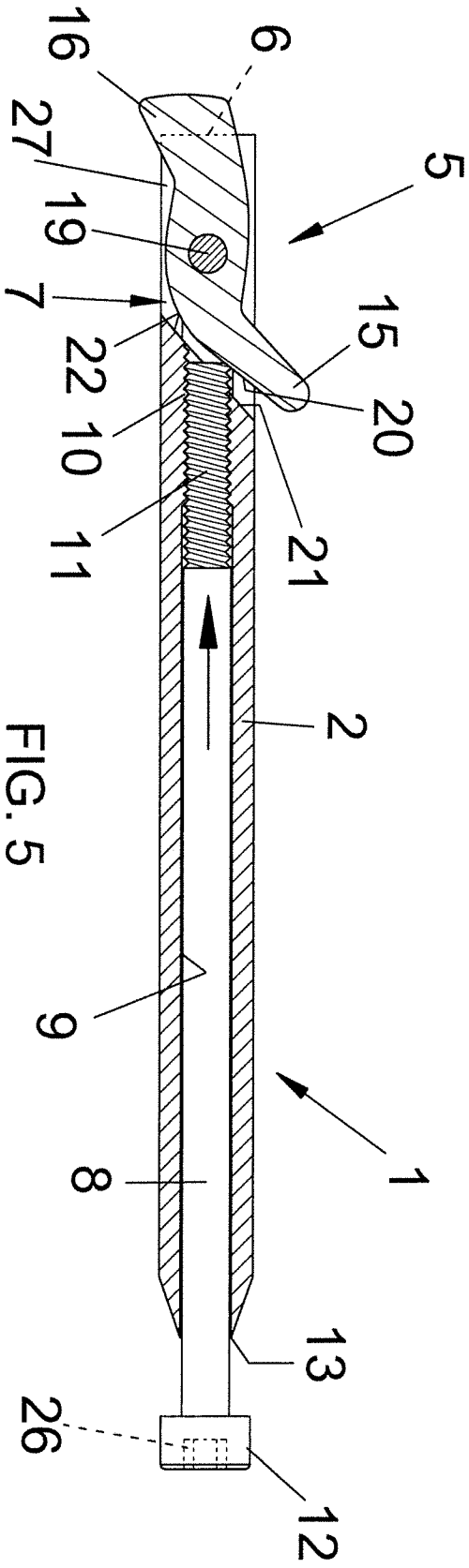

FIG. 5

INTERNATIONAL SEARCH REPORT

International application No
PCT/EP2020/058117

A. CLASSIFICATION OF SUBJECT MATTER
INV. E05B3/08 E05B15/00
ADD.
According to International Patent Classification (IPC) or to both national classification and IPC

B. FIELDS SEARCHED
Minimum documentation searched (classification system followed by classification symbols)
E05B

Documentation searched other than minimum documentation to the extent that such documents are included in the fields searched

Electronic data base consulted during the international search (name of data base and, where practicable, search terms used)
EPO-Internal

C. DOCUMENTS CONSIDERED TO BE RELEVANT

Category*	Citation of document, with indication, where appropriate, of the relevant passages	Relevant to claim No.
X	DE 30 25 553 A1 (PRACT GUENTHER) 4 February 1982 (1982-02-04)	1,3-10
A	the whole document	2
A	DE 15 53 444 B1 (DREXELIUS METALL FRANZ) 1 October 1970 (1970-10-01)	1-10
A	DE 77 09 187 U1 (FRANZ DREXELIUS METALLVERARBEITUNG [DE]) 8 September 1977 (1977-09-08) page 5, line 17 - page 6, line 5; figures 1-2	1-10
A	JP 2016 211278 A (KAWAJUN CO LTD) 15 December 2016 (2016-12-15) paragraph [0028]; figures 1-12	1-10
	-/--	

Further documents are listed in the continuation of Box C.

See patent family annex.

* Special categories of cited documents :

- "A" document defining the general state of the art which is not considered to be of particular relevance
- "E" earlier application or patent but published on or after the international filing date
- "L" document which may throw doubts on priority claim(s) or which is cited to establish the publication date of another citation or other special reason (as specified)
- "O" document referring to an oral disclosure, use, exhibition or other means
- "P" document published prior to the international filing date but later than the priority date claimed

- "T" later document published after the international filing date or priority date and not in conflict with the application but cited to understand the principle or theory underlying the invention
- "X" document of particular relevance; the claimed invention cannot be considered novel or cannot be considered to involve an inventive step when the document is taken alone
- "Y" document of particular relevance; the claimed invention cannot be considered to involve an inventive step when the document is combined with one or more other such documents, such combination being obvious to a person skilled in the art
- "&" document member of the same patent family

Date of the actual completion of the international search 15 May 2020	Date of mailing of the international search report 27/05/2020
--	--

Name and mailing address of the ISA/ European Patent Office, P.B. 5818 Patentlaan 2 NL - 2280 HV Rijswijk Tel. (+31-70) 340-2040, Fax: (+31-70) 340-3016	Authorized officer Robelin, Fabrice
--	--

INTERNATIONAL SEARCH REPORT

International application No
PCT/EP2020/058117

C(Continuation). DOCUMENTS CONSIDERED TO BE RELEVANT		
Category*	Citation of document, with indication, where appropriate, of the relevant passages	Relevant to claim No.
A	DE 40 24 614 A1 (GOLDSCHMIDT BAUBESCHLAEGE [DE]) 6 February 1992 (1992-02-06) column 3, line 42 - line 47; figure 1 -----	1-10
A	GB 465 444 A (IJZERHANDEL I M DE VRIES NV; ABRAHAM DE VRIES) 7 May 1937 (1937-05-07) the whole document -----	1-10

INTERNATIONAL SEARCH REPORT

Information on patent family members

International application No

PCT/EP2020/058117

Patent document cited in search report	Publication date	Patent family member(s)	Publication date
DE 3025553	A1	04-02-1982	NONE

DE 1553444	B1	01-10-1970	NONE

DE 7709187	U1	08-09-1977	NONE

JP 2016211278	A	15-12-2016	CN 106150193 A 23-11-2016
			JP 6564612 B2 21-08-2019
			JP 2016211278 A 15-12-2016

DE 4024614	A1	06-02-1992	NONE

GB 465444	A	07-05-1937	NONE
