

(19) **DANMARK**

(10) **DK/EP 2781606 T3**



(12) **Oversættelse af  
europæisk patentskrift**

Patent- og  
Varemærkestyrelsen

- 
- (51) Int.Cl.: **C 14 B 1/02 (2006.01)**                      **C 14 B 15/00 (2006.01)**                      **C 14 B 17/00 (2006.01)**  
**C 14 B 17/02 (2006.01)**                      **C 14 B 17/04 (2006.01)**                      **C 14 B 17/14 (2006.01)**
- (45) Oversættelsen bekendtgjort den: **2018-07-23**
- (80) Dato for Den Europæiske Patentmyndigheds bekendtgørelse om meddelelse af patentet: **2018-05-16**
- (86) Europæisk ansøgning nr.: **13160217.9**
- (86) Europæisk indleveringsdag: **2013-03-20**
- (87) Den europæiske ansøgnings publiceringsdag: **2014-09-24**
- (84) Designerede stater: **AL AT BE BG CH CY CZ DE DK EE ES FI FR GB GR HR HU IE IS IT LI LT LU LV MC MK MT NL NO PL PT RO RS SE SI SK SM TR**
- (73) Patenthaver: **HEDENSTED GRUPPEN A/S, Vejlevej 15, 8722 Hedensted, Danmark**
- (72) Opfinder: **Madsen, Jens Jørgen, Klappen 5, 5220 Odense SØ, Danmark**  
**Lange, Kent, Mølletofte 3, 8763 Rask Mølle, Danmark**
- (74) Fuldmægtig i Danmark: **COPA COPENHAGEN PATENTS K/S, Rosenørns Allé 1, 2. sal, 1970 Frederiksberg C, Danmark**
- (54) Benævnelse: **Skindbearbejdningsapparat med to skraberulleenheder**
- (56) Fremdragne publikationer:  
**EP-A1- 2 093 299**  
**EP-A1- 2 599 880**  
**WO-A1-92/02643**  
**WO-A1-2012/019606**  
**GB-A- 2 086 936**  
**US-A- 4 745 782**  
**US-A- 4 989 427**



# DESCRIPTION

## FIELD OF THE INVENTION

**[0001]** The present invention relates to the field of processing of fur, such as mink fur, and more specifically the invention provides a skinning or fleshing apparatus for scraping fat and flesh of a leather side of a fur.

## BACKGROUND OF THE INVENTION

**[0002]** Processing of fur, e.g. mink fur, often includes a process of removing fat and flesh residues from the back side of the fur by means of a skinning or fleshing apparatus with rotating scraper rollers that remove the fat and flesh during contact with the back side of the fur under pressure.

**[0003]** An example of a fleshing apparatus is disclosed in EP 2 093 299 B1 by Pamutec. This apparatus has an elongated mandrel on which the fur is mounted with its fur side facing inwards. Several rotating scraper rollers and brushes inside the apparatus serve to remove fat and flesh and thus clean the fur while the mandrel is projected through the rotating scraper rollers which are pressed against the fur on the mandrel. More specifically EP 093 299 B1 discloses a fur processing apparatus as stated in the preamble of claim 1.

**[0004]** However, it is a problem that fat and flesh is not completely removed in such apparatus, and thus the fur can suffer from spots due to fat residues penetrating the pores of the skin from the flesh side to the fur side during the subsequent drying process. Thus, to improve the quality of the fur, it is important to remove as much fat as possible in the scraping process.

**[0005]** It is a further problem that fat and flesh can sometimes be so sticky that it is not thrown off the scraper rollers due to centrifugal forces caused by the rotation of the scraper rollers. Thus, fat and flesh may add up between the scraper blades on the scraper rollers, thus reducing the scraping effect significantly. Sometimes, a complete stop and cleaning of the scraper rollers is required. Such problems can be reduced by the introduction of suction systems that serve to vacuum fat and flesh pieces off the scraper rollers. However, a suction system for this purpose is rather expensive, and further such system adds several single elements to the fleshing machine which increases the risk of break-down, and still further a separate cleaning procedure of such suction system is required.

**[0006]** US 4989427 discloses a fleshing machine comprising a longitudinally movable support for supporting a hide or pelt and a scraper roller for scraping a hide or pelt arranged on the support. It is mentioned that a water or air jet can be used to clean the roller and knives

thereof.

**[0007]** GB 2086936 discloses a fleshing machine comprising a movable support for a skin, the support being an elastic belt being movable towards a rotatable fleshing roller having radial teeth for fleshing the skin. A water spray is sprayed against the roller from above the roller for removing fat and flesh. It has been proposed in the prior art to apply a particulate material such as sawdust onto the fur for facilitating scraping of fur. However, the provision of such particulate material increases the complexity of the apparatus and hence adds to the cost thereof. In particular, conveying means for the material are to be provided, cleaning is impeded, and means are required for separating fat from particulate material after the material has been in contact with the fur in order to avoid particles in the fat, which could cause damage to pumping means for pumping away fat, and in order to avoid fat in sawdust which may have to be recycled.

### **SUMMARY OF THE INVENTION**

**[0008]** Following the above description, it may be seen as an object of embodiments of the present invention to provide a fur processing device which can scrape the flesh side of the fur effectively free from fat and flesh residues, so as to improve the resulting fur quality. A further object of embodiments of the present invention may be to provide a fur processing device which can function reliably without the need for a suction system to prevent fat and flesh from destroying the effect of the scraper rollers. A further object of embodiments of the invention may be to provide an apparatus, which obtains sufficient scraping quality at reduced cost as compared to apparatus scraping in the presence of particulate material, such as sawdust.

**[0009]** In a first aspect, the invention provides a fur processing apparatus, such as for processing mink fur, the apparatus comprising

- a mandrel (M) arranged for mounting of the fur with the fur side facing inwards, such as a mandrel (M) having a rectangular cross section,
- a first scraper unit (SU1) comprising a plurality of first scraper rollers (S1\_1, 2\_1, S3\_1), the first scraper rollers being arranged to rotate and for being pressed into contact with the fur on the mandrel (M) while the first scraper rollers (S1\_2) rotate, and
- a second scraper unit (SU2) comprising a plurality of second scraper rollers (S1\_2, S2\_2, S3\_2) and at least one scraper plate (SF), the second scraper rollers being arranged to rotate and for being pressed into contact with the fur on the mandrel (M) while the second scraper rollers (S1\_2, S2\_2, S3\_2) rotate, the second scraper unit (SU2) being arranged after the first scraper unit (SU1), seen in a direction of forward movement of the mandrel (M) in the longitudinal direction thereof,

characterized in that the first scraper unit (SU1) further comprises at least one scraper plate (SF), and that the processing apparatus additionally comprises:

- at least two spray nozzles (or spray units) arranged to spray a liquid (L), such as water,

- onto the respective scraper rollers of the first and second scraper units (SU1;SU2);
- the spray nozzles being positioned and arranged on the side of the respective scraper rollers upstream from scraper roller blade contact with the fur for spraying liquid on the scraper roller blades immediately before they go into contact with the fur,
  - the liquid having a temperature within 30-90°C, such as within 40-85°C, such as within 50-80°C, when being sprayed onto the respective scraper rollers.

**[0010]** Prereably, no material dispenser is provided for applying an amount of particles, such as sawdust, to the fur between the first scraper unit and the second scraper unit, seen in a direction of forward movement of the mandrel (M).

**[0011]** Such fur processing apparatus is advantageous for fleshing or scraping of fur, such as mink fur, since the problem of fat and flesh residues is reduced compared to prior art apparatuses. This provides furs of higher quality.

**[0012]** Still, the apparatus can perform the complete scraping process automatically without the need for any manual operation involved other than placing the fur on the mandrel when it is in its initial position.

**[0013]** It has been found that the provision of sprays for spraying a liquid onto the scraper rollers of the first and second scraper units improves scraping results.

**[0014]** The apparatus preferably comprise a set of scraper plates, such as made of rubber or a polymeric material or metal, arranged to scrape the fur, wherein the set of scraper plates are arranged between the first scraper unit and the second scraper unit, seen in a direction of forward movement of the mandrel. Further scraper plates are preferably provided after the second scraper unit.

**[0015]** The problem of fat and flesh sticking to the scraper rollers can be eliminated or at least reduced by spraying liquid, e.g. water in rather small amounts on the scraper roller. By spraying liquid towards a back side of a scraper blade immediately before contact with the fur serves to provide a liquid film on the front side of the scraper blade which helps to prevent fat and flesh from sticking to the scraper blade. Thus, the fat and flesh which is scraped off the fur by the scraper blade can easier be thrown off the scraper blade due to the centrifugal forces of the scraper roller rotation. Hereby, poor effect of the scraper rollers can be eliminated or at least reduced even without the use of a dedicated suction system to prevent the fat and flesh from sticking to the scraper rollers. The amount of water can be small, and the liquid spray unit can be implemented with low cost components, thus solving the same problem as an expensive and maintenance requiring suction system.

**[0016]** Further, with the added liquid film, it may under some operating conditions be possible to reduce the pressure applied to the scraper rollers for contacting the fur, and still obtain the

desired scraping effect. Such reduced pressure can be advantageous for obtaining a high fur quality. This is due to a high scraping pressure which tends to press fat into the pores of the skin from the leather side of the fur, and such fat into the pores of the skin will in some cases result in unwanted fat spots on the fur side after a period of storage, thus reducing overall quality of the piece of fur.

**[0017]** Still further, at least part of the sprayed liquid, e.g. water, will end up on the fur during the scraping process. The liquid spray unit comprises at least one nozzle positioned in relation to some or preferably all of the the scraper rollers so as to spray liquid towards at least one point of a surface of the scraper roller. Such nozzle, or a set of a plurality of nozzles for each scraper roller, may be arranged to spray liquid in various patterns. However, it may especially be preferred to cover the length of the roller with a plurality of single jets, or with one single nozzle arranged to spray liquid in an elongated pattern oriented to cover the entire length of the scraper roller, or at least a large part of the length of the scraper roller. Thus, in some embodiments, the nozzle may be arranged to spray liquid over a width of  $100^\circ$  or more to cover the entire length or at least a large part of the length of the scraper roller, whereas the spray pattern is preferably limited to such as below  $60^\circ$ , such as below  $40^\circ$ , such as below  $20^\circ$ , or even below  $10^\circ$ , perpendicular to that direction. The at least one nozzle is positioned in relation to the at least one scraper roller such that it is arranged to spray liquid towards one side of the at least one scraper roller so as to provide a liquid film (LF) on one or more scraper blades prior to rotating into contact with the fur. Thus, to prevent the liquid from being thrown off due to centrifugal forces due to the rotation of the scraper roller, or to be sprayed onto fat and flesh not having left the scraper blades, the at least one nozzle is positioned on the side of the scraper roller upstream from scraper blade contact with the fur, thus spraying liquid on scraper blades immediately before they go into contact with the fur. Especially, the at least one nozzle is positioned so in relation to an axis of rotation of the at least one scraper roller that the at least one nozzle is positioned within an angular interval of  $0^\circ$  to  $60^\circ$ , seen in relation to a point of contact between the at least one scraper roller and the fur, and a plane extended by a surface of the mandrel at the point of contact between the at least one scraper roller and the fur. More specifically, the angular interval may be  $10^\circ$  to  $45^\circ$ , such as  $15^\circ$  to  $40^\circ$ . Hereby, an appropriate liquid film is provided on the front side of a scraper blade immediately before entering into contact with the fur, even though the liquid is sprayed towards the back side of the scraper blade.

**[0018]** The liquid spray unit may be arranged to spray the liquid in atomized or at least partly atomized form. Hereby, a very small amount of liquid can be used, and still provide the necessary liquid film on the scraper blades. However, it is understood that various other forms of liquid spreading can be used to provide the liquid film.

**[0019]** In some embodiments, the apparatus comprises a mandrel support serving to support the mandrel in a horizontal direction to decrease a bending of the mandrel upon engagement of the at least one scraper roller of the first scraper unit. The mandrel support may be in the form of a wheel or roller mounted below the mandrel and in contact with the mandrel so as to support its downward bending during engagement with the scraper rollers. Hereby, a higher

pressure can be applied to the scraper rollers, thus providing a more efficient scraping, especially of the head part of the fur. The mandrel support may comprise a roller arranged to support the mandrel, wherein the mandrel support is arranged between the base of the mandrel and the first scraper unit. E.g. the roller may be positioned around midway between the base of the mandrel and the first scraper unit, however a good effect can be obtained also with the mandrel support in other positions along the mandrel. The roller may be mounted on an air or pneumatic cylinder, hereby allowing the roller to be disengaged. The mandrel support may have a fixed position in a length direction of the mandrel, however in other embodiments the mandrel support may be mounted to be movable in a length direction of the mandrel, such as the mandrel support being mounted on a sliding arrangement which is fixed to a frame of the apparatus. Especially, the mandrel support may be movable together with movement of the mandrel, e.g. the mandrel support may be mounted so as to synchronously follow the forward and backward movement of the mandrel.

**[0020]** In preferred embodiments, the first scraper unit comprises a set of horizontal scraper rollers, and a set of vertical scraper rollers. The apparatus preferably further comprises a second scraper unit comprising a set of horizontal scraper rollers, and a set of vertical scraper rollers. Especially, the scraper rollers of the second scraper unit may be of the same type as the scraper rollers of the first scraper unit, however the scraper rollers of the second scraper unit may be of a different type than the scraper rollers of the first scraper unit, such as scraper rollers with a different diameter, a different material, a different number of teeth, and/or different size of the teeth. Such difference in type of scraper roller between the first and second scraper unit may provide an improved scraping quality, since it is possible to select a type of scraper roller for the first scraper unit which is suited to remove large amount of fat and flesh, whereas the type of scraper roller for the second scraper unit may be specially designed to remove minor pieces of fat and flesh.

**[0021]** The liquid spray units may be arranged to spray liquid towards the plurality of scraper rollers of the first and second scraper unit. It is preferred to provide liquid spraying to all scraper rollers of the first and second scraper units, e.g. on all horizontal scraper rollers and vertical scraper rollers to obtain efficient cleaning of the fur. The liquid spray units may comprise a plurality of nozzles arranged to spray liquid towards respective scraper rollers of the first scraper unit.

**[0022]** The scraper rollers and the plurality of scraper blades may be formed by one monolithic structure with a generally cylindrical shape with the scraper blades formed thereon in the monolithic material, such as a polymeric monolithic material. However, the scraper roller may alternatively be formed by a roller body with separate scraper blade members arranged thereon.

**[0023]** The liquid spray unit may be arranged to spray a predetermined amount of liquid per time towards one scraper roller, such as within 0.1-10 liters per minute, such as within 0.2-5 liters per minute, such as within 0.3-3 liters per minute, such as within 0.4-1 liters per minute, during normal operation. However, the liquid spray unit may be arranged to vary the amount of

liquid per time to be applied to one scraper roller, so as to provide an optimal effect in specific situations, and still to allow a minimum amount of liquid to be used.

**[0024]** In some embodiments, the liquid spray unit may comprise a controller arranged to control the liquid spraying. Such controller may be formed as part of the general controller of the apparatus, however it may be formed as a separate digital processor unit dedicated to control the liquid spraying. The controller may have various functions, such as controlling at least one of: an amount of liquid to spray, when to spray liquid, such as to switch on and off liquid spraying, such as to switch on liquid spraying when the at least one scraper roller enters into contact with the fur, and to switch off liquid spraying when the least one scraper roller is not in contact with the fur.

**[0025]** The liquid has a temperature within 30-90°C, such as within 40-85°C, such as within 50-80°C, when being sprayed onto the at least one scraper roller. Hereby, having an elevated temperature compared to a normal environmental temperature, the optimal fat and flesh loosening effect is obtained, and further the task of pumping away the removed fat and flesh is facilitated.

**[0026]** Preferably, the liquid is water however other liquids could be used as well. E.g. the liquid may be water with an additive, such as a detergent or the like, and which is still not harmful for the fur. Thus, in simple embodiments, the liquid spray unit comprises pipes connected to a normal fresh water supply and with the pipe ends, e.g. with nozzles mounted thereon, pointing towards one or more scraper rollers of the skinning or fleshing apparatus. Especially, the liquid supply may be a normal hot water supply, or a normal cold or hot water supply on which an intermediate heater is installed to heat the water temperature up to such as 60-90 °C.

**[0027]** In one embodiment, the horizontal scraper rollers of the second scraper unit are positioned before the vertical scraper rollers of the second scraper unit, seen in a direction of forward movement of the mandrel. Hereby, it is possible to reduce the length of the machine by such as 15 cm, due to the tail part of a mink fur placed only on the horizontal part of the mandrel, is then being scraped with a shorter stroke of the mandrel. This means a higher efficiency of the machine.

**[0028]** Preferably, the mandrel has a rectangular cross section, at least on its front part, where the mandrel is arranged for the fur to be placed. However, it is to be understood that the invention may also be used with mandrels of other cross sections, such as triangular, or pentagonal or the like. Preferably, the scraper units have scraper rollers angularly arranged to match the cross section of the mandrel, so as to scrape all sides of the fur when placed on the mandrel.

**[0029]** In a specific embodiment, the mandrel has a rectangular cross section, and a scraping arrangement comprises a sequence of: a first scraper unit with four rotating scraper rollers including liquid spraying, followed by a set of scraping plates, such as four scraping plates,

followed by a second scraper unit with four rotating scraper rollers with liquid spraying, followed by a further set of scraping plates, such as four scraping plates. After the second scraping unit, the apparatus preferably has a fur removing arrangement for pulling off the fur from the mandrel, before the mandrel returns to its initial position for processing a new fur.

**[0030]** The apparatus may comprise a clamping arrangement arranged to clamp a head or nose part of fur to the mandrel, preferably to the frontal tip of the mandrel, during scraping. Such arrangement is advantageous, since it allows a firm fit of the fur to the mandrel, thus allowing a high scraping pressure to be used. Especially, it is preferred that the clamping arrangement is capable of firmly clamping furs where a head part is at least partly damaged. Preferably, the clamping arrangement is automatically engaged upon activating the fur processing. It is to be understood that different types of clamping shapes can be used, depending on the type of fur.

**[0031]** In preferred embodiments, the first and second scraper units are housed within one common casing. However, in other embodiments, the second scraper unit comprising two or four scraper rollers may be provided as an add-on kit for mounting outside a casing.

**[0032]** In a second aspect, the invention provides a method for scraping a fur according to claim 14. It is understood that the same advantages as described for the first aspect apply as well for the second aspects, and the same principal embodiments from the first aspect apply as well for the second aspect. The first and second aspects may each be combined with any of the other aspects. These and other aspects of the invention will be apparent from and elucidated with reference to the embodiments described hereinafter. It will further be understood that liquid spraying may be omitted in respect of the first set of scraper rollers SU\_1.

## **BRIEF DESCRIPTION OF THE FIGURES**

**[0033]** Embodiments of the invention will be described in more detail in the following with regard to the accompanying figures. The figures show one way of implementing the present invention and is not to be construed as being limiting to other possible embodiments falling within the scope of the attached claim set.

Fig. 1 shows a partly exploded side view of an embodiment of an apparatus according to the present invention;

Fig. 2 shows an example of a liquid spray nozzle positioned to spray liquid on a scraper roller;

Fig. 3 shows a detail of scraper rollers and liquid spray nozzles;

Fig. 4 shows a side view of a further embodiment of an apparatus according to the invention.

**DETAILED DESCRIPTION OF AN EMBODIMENT**

**[0034]** Fig. 1 shows a first embodiment of an apparatus (skinning machine) according to the present invention. The machine has an elongated mandrel M with a rectangular cross section is arranged for receiving a mink fur with the head end arranged at the tip of the mandrel M, i.e. to the right on Fig. 1. The mandrel M is shown in its initial position where it is prepared for a fur to be mounted. During operation, the mandrel M is driven along its longitudinal axis, i.e. in the direction indicated by the bold arrow, so as to process the fur by a scraper arrangement with rotating scraper rollers arranged to remove remaining fat and flesh pieces on the leather side of the fur.

**[0035]** The scraper arrangement has two scraper units with scraper rollers. The first unit of scraper rollers by which the fur is processed when the mandrel M is driven forwards, has four scraper rollers, of which only three are visible, namely two horizontal scraper rollers S1\_1, S2\_1 which are placed on opposite sides of the mandrel M during operation, and two vertical scraper rollers of which only the nearest one S3\_1 is visible. The not visible vertical scraper roller is placed behind S3\_1, and during operation the two vertical scraper rollers S3\_1 are placed on opposite sides of the mandrel M. The four scraper rollers S1\_1, S2\_1, S3\_1 are thus placed to cover all sides of the fur when placed on the rectangular mandrel M. Fat and flesh removed by the scraper rollers S1\_1, S2\_1, S3\_1 is pumped away by a motor driven pump FP. Liquid spray nozzles N are provided for spraying liquid, such as water, onto the scraper rollers for facilitating removal of fat and meat therefrom. After processing by the first scraper unit, the fur is scraped by a first set of scraper plates SF for scraping fat and flesh off the leather side of the fur. The set of scraper plates preferably comprises four blades for scraping respective horizontal and vertical surfaces of the fur mounted on the mandrel. Subsequently, when the mandrel M is driven further forward, the fur is processed by a second scraper unit to remove the last pieces of fat and flesh. Three out of the four scraper rollers of the second scraper unit are visible S1\_2, S2\_2, S3\_2. Liquid spray nozzles N are provided for spraying liquid, such as water, onto the scraper rollers for facilitating removal of fat and meat therefrom. After processing by the second scraper unit, the fur is scraped by a second set of scraper plates SF for scraping fat and flesh off the leather side of the fur. The set of scraper plates preferably comprises four plates for scraping respective horizontal and vertical surfaces of the fur mounted on the mandrel. The scraper rollers and the scraper plates operate in the absence of any particulate material, such as sawdust.

**[0036]** All eight scraper rollers are driven by respective electric motors.

**[0037]** The scraper plates SF may be of rubber or a polymeric material or metal, which scrape the fur, when the mandrel M is projected forwards so that the fur passes the scraping plates SF.

**[0038]** As shown in Fig. 1, a mandrel support MS is provided for reducing horizontal bending

of the mandrel M upon engagement with the scraper rollers of the first scraper unit SU1. Hereby, it is possible to provide a more efficient scraping of the head part of the skin, since it is possible to use a higher scraping pressure on the scraper rollers of the first scraper unit SU1. In Fig. 1 the mandrel support MS is shown in the form of a wheel or roller supporting the mandrel M placed below the mandrel M so as to support it in a horizontal direction. The wheel or roller is mounted on an air or pneumatic cylinder to provide a mandrel support which can be removed or disengaged by activating the cylinder, and the opposite end of the air or pneumatic cylinder is mounted on the non-moving frame of the machine. However, it is to be understood that the mandrel support MS may alternatively be mounted movably in a length direction, e.g. so as to follow the forward movement of the mandrel M.

**[0039]** A material dispenser (not shown) for dispensing sawdust onto the cleaned fur may be provided downstream of the second scraper unit SU2. A fur removing arrangement may further be provided arranged for removing the fur from the mandrel after it has passed the second scraper unit. Subsequently, the mandrel is moved backwards in its length direction to its initial position, ready for a new fur to be mounted and processed.

**[0040]** The apparatus may include a control system arranged to control, either manually or automatically according to a control algorithm, a pressure to be applied to the scraper rollers during scraping. Especially, the control system may be arranged to apply different scraping pressures to different zones of the fur, such as individual pressures for two, three or more different zones of the fur.

**[0041]** The mandrel may include a heating arrangement arranged to heat the mandrel and thus also heat the fur during processing. The apparatus may further include a washing arrangement arranged to wash the mandrel during its return to its initial position.

**[0042]** Fig. 1 shows a side view of a scraper roller S with ten scraper blades formed monolithically on the scraper roller as protruding teeth. Typically, a scraper roller with 7-10 teeth is used. The scraper roller S is shown in position for normal operation, namely where it is pressed against a mandrel M which has a fur (not specifically shown) arranged thereon with its leather side facing outwards. During rotation (rotation direction is indicated by the arrow on the scraper roller S), the teeth of the scraper roller S serve to remove fat and flesh F from the leather side of the fur, and as seen, pieces of fat and flesh F are carried between the teeth of the scraper roller S and preferably thrown off the scraper roller S due to centrifugal forces before the teeth re-enter into contact with the fur after a full rotation.

**[0043]** To help to release such fat and flesh F pieces from the scraper roller S, a liquid spray unit is provided. For simplicity, only a nozzle N of such unit is provided. The nozzle N is positioned near the scraper roller S, e.g. such as at a distance of 10 cm, such as 2-10 cm, such as 4-8 cm, from a periphery of the scraper roller S. The nozzle N sprays liquid L towards a back side of one or more scraper blade(s) of the scraper roller S with the purpose of providing a liquid film LF on a front side of the one or more scraper blade(s) immediately before entering into contact with the fur, which takes place at point P. To do so with a minimum amount of liquid

L, e.g. water, the nozzle N is positioned on the side of the scraper roller S where fat and flesh F pieces have preferably been thrown off, thus allowing a liquid film LF to be provided on a front side of the scraper blade. A preferred angular interval A is indicated for position of the nozzle N. Preferably, the nozzle is positioned so in relation to an axis of rotation of the at least one scraper roller S that it is within A being  $0-60^\circ$ , seen in relation to the point of contact P between the scraper roller S and the fur, and a plane PL extended by a surface of the mandrel M at the point of contact P between the scraper roller S and the fur. More preferably, the nozzle N is positioned within A being  $5-50^\circ$ , more preferably within A being  $10-45^\circ$ .

**[0044]** It is understood that the nozzle N can spray liquid L in a pattern suitable to provide the liquid film LF taking into account a number of parameters such as the speed of rotation of the scraper roller S, the shape and number of scraper blades on the scraper roller S, and the actual position of the nozzle N in relation to the scraper roller S. However, in general the liquid film LF may be provided by various spraying patterns from one single jet of liquid to an atomization nozzle creating a cloud of liquid. Only one nozzle N is shown in Fig. 1, however depending on the length of the scraper roller S (i.e. a length of the scraper roller S perpendicular to the plane of Fig. 1), several single nozzles N may be positioned along the length of the scraper roller S to ensure that a proper liquid film LF is provided throughout the length of the scraper roller S. Especially, one single nozzle N may be positioned at a distance and with a spraying pattern which is wide enough to cover the entire length of the roller, while the height of the spraying pattern is preferably rather narrow.

**[0045]** The function of the liquid spray is improved, if the temperature of the liquid is elevated, e.g.  $40-60^\circ\text{C}$  or even more, such as  $60-90^\circ\text{C}$ . This elevated temperature both serves to prevent the fat and flesh pieces to stick to the scraper blade, but it also helps to facilitate removal of the fat and flesh pieces. Thus, water from a normal hot water supply source can preferably be used as liquid. Preferably, the amount of water used is small, i.e. as small as possible provided that a suitable fat and flesh loosening effect is obtained. However, it has been found that less than below 10 liters per minute is sufficient, and even below 2 liters per minute can provide the desired effect.

**[0046]** Fig. 3 shows a detail of the first scraper unit of the apparatus of Fig. 1 where an example of a liquid spray unit is sketched. As seen, nozzles N1\_1, N2\_1, N3\_1 are positioned to spray liquid on respective scraper rollers S1\_1, S2\_1, S3\_1. The nozzles N1\_1, N2\_1, N3\_1 are positioned in relation to the scraper rollers S1\_1, S2\_1, S3\_1 as indicated and explained in connection with Fig. 1, and for the nozzle N3\_1 on the vertical scraper roller S3\_1, it is seen that it is positioned near the middle of the length of the scraper roller S3\_1 so as to ensure a scattering of the liquid sprayed towards the scraper roller S3\_1 in order to provide a liquid film covering the entire length of the scraper roller S3\_1. The same position of the nozzles N1\_1, N2\_1 in relation to the scraper rollers S1\_1, S2\_1 is also preferred. However, as already mentioned, more nozzles may be used for each scraper roller, if preferred.

**[0047]** The nozzles N1\_1, N2\_1, N3\_1 are supplied with liquid from a liquid pipe system which is supplied with liquid from a liquid supply LS, e.g. a normal hot water or cold water supply. As

seen, the liquid supply LS is connected to the nozzles N1\_1, N2\_1, N3\_1 via a controller C which serves to control the amount of liquid to be supplied, and also to start supply of liquid when the scraper rollers S1\_1, S2\_1, S3\_1 enter into contact with the fur, and to stop the supply of liquid when the scraper rollers S1\_1, S2\_1, S3\_1 are not in contact with the fur. Even though it is to be understood that the invention can be performed by a simple supply of water from a pipe connected to a cold or hot water supply which is manually turned on or off, it is preferred to have a controller C so as to allow automated control of the liquid spraying and still with a minimum generation of waste water. The controller C may be controlled by a processor running a predetermined control algorithm, e.g. the controller can be implemented as a PLC or the like controlling one or more valves. In some versions, the controller may be arranged to vary the amount of liquid or the liquid pressure in response to one or more parameters, such as liquid temperature, speed of rotation of the scraper rollers etc.

**[0048]** An identical nozzle configuration is provided in respect of the scraper rollers S1\_2, S2\_2, S3\_2 and S4\_2 (see Figs. 1 and 4) of the second scraper unit SU2.

**[0049]** The controller C may either provided as a separate liquid spray unit controller C, or it can alternatively be implemented as an integrated part of the general control of the skinning machine. E.g. a unit of one or more valves may be controlled by a single control signal. One common liquid supply to all nozzles may be controlled by control of one or more valves, or alternatively, each nozzle may be controllable, thus providing a constant liquid supply to all nozzles, and then controlling the liquid supply individually for each nozzle by means of a signal, such as an air signal, an electric signal, or a mechanical signal.

**[0050]** Fig. 4 shows an example of a further embodiment of skinning machine. As in the embodiment of Fig. 1, an elongated mandrel M with a rectangular cross section is arranged for receiving a mink fur with its head end arranged at the tip of the mandrel M, i.e. to the right on Fig. 4. The machine operates in a similar manner as the machine of Fig. 1.

**[0051]** The scraper arrangement has two scraper units with scraper rollers. The first unit of scraper rollers by which the fur is processed when the mandrel M is driven forwards, has four scraper rollers, of which only three are visible, namely two horizontal scraper rollers S1\_1, S2\_1 which are placed on opposite sides of the mandrel M during operation, and two vertical scraper rollers of which only the nearest one S3\_1 is visible. The not visible vertical scraper roller is placed behind S3\_1, and during operation the two vertical scraper rollers S3\_1 are placed on opposite sides of the mandrel M. The four scraper rollers S1\_1, S2\_1, S3\_1 are thus placed to cover all sides of the fur when placed on the rectangular mandrel M. Fat and flesh removed by the scraper rollers S1\_1, S2\_1, S3\_1 is pumped away by a motor driven pump. Liquid nozzles (see N in Fig. 1) may be provided for spraying liquid onto the scraper rollers and after processing by the first scraper unit, the fur is scraped by scraper plates SF (see Fig. 1). Subsequently, when the mandrel M is driven further forward, the fur is processed by a second scraper unit to remove the last pieces of fat and flesh. Liquid sprays are provided at the second set of scraper rollers as well, and scraper plates are provided downstream thereof (see Fig. 1) Three out of the four scraper rollers of the second scraper unit are visible

S2\_2, S3\_2, and S4\_2.

**[0052]** The mandrel M preferably has a closed, planar outer surface in order to avoid fat and flesh entering cavities or depressions therein. The mandrel is preferably solid in order to allow it to be suspended at one end only and yet to be able carry its own weight.

**[0053]** Generally, the mandrel M may be driven at constant or at variable speed. It has been found that the removal of flesh and fat from the neck region of mink fur is more troublesome than the removal of flesh and fat from the remaining body part of mink fur. Accordingly, the mandrel may be driven at a variable speed, so that the neck region of the mink fur is conveyed past the scraper rollers at a lower speed than the body part of the mink fur. In one example, the apparatus is operable such that the speed of the mandrel is increased steadily throughout the mandrel's movement. For example, the speed may be varied from about 1.5 to about 6 m/s, or such as from between 2 and 4.5 m/s. The speed variation may be selected by an operator of the apparatus through an appropriate user interface.

**[0054]** The scraper rollers may advantageously be suspended in such a way that they are firmly pressed against the mandrel and hence against the fur to be scraped. In embodiment of the present invention, the pressure by which the scraper rollers are pressed against the mandrel is variable in such a way that a first, high pressure is exerted in the neck region of the fur, i.e. at the foremost front part of the conical section of the mandrel. A slightly lower pressure may be provided at the rearward conical section of the front part of the mandrel, i.e. in the region of the forelegs of the fur. A third even lower pressure may be provided at the back part of the fur, i.e. at the non-conical main section of the mandrel.

**[0055]** The pressure, by which the scraper rollers are pressed against the mandrel and hence the fur is preferably controlled by suitable means, such as electric actuators or pneumatic cylinders providing a controlled biasing force of the scraper rollers towards the mandrel. In the case of pneumatic cylinders, control signals may preferably be provided as pressure signals provided from a control unit through air conduits to the pneumatic cylinders. The control unit continuously regulates the biasing pressure in response to a pressure or force measurement obtained from an appropriate sensing device. Whereas, in the prior art, the control units have been provided at a distance of some meters from the pneumatic cylinders, in preferred embodiments of the present invention, the control unit is provided closer to the pneumatic cylinder, most preferably at a distance of at most 2 meters therefrom in order to reduce the control reaction delay when the control signals travel through the air conduits. It has surprisingly been found that such reduction of the distance between the pneumatic cylinders and the control unit and hence of the length of the air conduits for pressure control signals improves scraping quality. In the prior art, uneven scraping results have been observed, notably at the neck region of mink fur. A firm belief has existed in the art that such unevenness was due to uneven surface structures of the mandrel. However, the present inventors have found that the reduction of the control signal delay significantly improves the evenness of the scraping results. In other words, the reduction of the length of air conduits for pressure control signals and hence inaccurate biasing pressure control has surprisingly been found to constitute

a major cause of uneven scraping results.

**[0056]** In one embodiment of the invention, the control unit is placed directly at the pneumatic cylinders with air conduits for pressure control signals having a length of at most 20 cm or even with the pneumatic cylinders being attached directly to the control unit with no air conduits therebetween.

**[0057]** Although the present invention has been described in connection with the specified embodiments, it should not be construed as being in any way limited to the presented examples. The scope of the present invention is set out by the accompanying claim set. In the context of the claims, the terms "comprising" or "comprises" do not exclude other possible elements or steps. Also, the mentioning of references such as "a" or "an" etc. should not be construed as excluding a plurality. The use of reference signs in the claims with respect to elements indicated in the figures shall also not be construed as limiting the scope of the invention. Furthermore, individual features mentioned in different claims, may possibly be advantageously combined, and the mentioning of these features in different claims does not exclude that a combination of features is not possible and advantageous.

## REFERENCES CITED IN THE DESCRIPTION

This list of references cited by the applicant is for the reader's convenience only. It does not form part of the European patent document. Even though great care has been taken in compiling the references, errors or omissions cannot be excluded and the EPO disclaims all liability in this regard.

### Patent documents cited in the description

- [EP2093299B1](#) [0003]
- [EP093299B1](#) [0003]
- [US4989427A](#) [0006]
- [GB2086936A](#) [0007]

## KRAV

1. Skindbearbejdningsapparat, såsom til bearbejdning af minkskind, hvilket apparat omfatter
  - 5 - en stok (M), som er indrettet for derpå at anbringe skindet med hårsiden vendende indad, såsom en stok (M) med rektangulært tværsnit,
  - en første skrabeenhed (SU1) omfattende en flerhed af første skraberuller (S1\_1, S2\_1, S3\_1), hvor de første skraberuller (S1\_2) er indrettet til at rotere og blive presset ind i kontakt med skindet på stokken (M) medens de første skraberuller (S1\_2) roterer, og
  - 10 - en anden skraberulleenhed (SU2) omfattende en flerhed af anden skraberuller (S1\_2, S2\_2, S3\_2), og mindst en skrabeplade (SF), hvor de anden skraberuller er indrettet til at rotere og til at blive presset ind i kontakt med skindet på stokken (M) medens de anden skraberuller (S1\_2, S2\_2, S3\_2) roterer, hvilken anden skrabeenhed (SU2) er anbragt efter den første skrabeenhed (SU1) set i stokkens (M) fremadgående bevægelse i dens
  - 15 længderetning,  
**kendetegnet ved**, at den første skrabeenhed (SU1) yderligere omfatter mindst en skrabeplade (SF), og at bearbejdningsapparatet yderligere omfatter
  - mindst to sprøjtedyser eller enheder, der er indrettet til at sprøjte en væske (L), såsom vand, på de respektive skraberuller (S1\_1, S2\_1, S3\_1; S2\_2, S2\_2, S3\_2) hørende til den
  - 20 første og den anden skrabeenhed (SU; SU2)
    - hvor sprøjtedyserne er anbragt og indrettet på den side af de respektive skraberuller, der er opstrøms i forhold til skraberulletændernes kontakt (P) med skindet, for at sprøjte væske (L) på skraberulletænderne, umiddelbart før de kommer
    - 25 i kontakt med skindet,
    - hvilken væske har en temperatur mellem 30 og 90 °C, såsom mellem 40 og 85 °C, såsom mellem 50 og 80 °C, når væsken sprøjtes på de respektive skraberuller (S1\_1, S2\_1, S3\_1; S2\_1, S2\_2, S3\_2).
- 30 2. Apparat ifølge krav 1, omfattende et første sæt af skrabeplader (SF), som er fremstillet af f.eks. gummi eller et polymert materiale eller metal, og som er indrettet til at skrabe skindet, og hvor sættet af skrabeplader (SF) er anbragt mellem den første skraberulleenhed (SU1) og den anden skraberulleenhed (SU2), set i stokkens (M) fremadgående bevægelsesretning.

3. Apparat ifølge et hvilket som helst af de foregående krav, omfattende et andet sæt af skrabeplader (SF), som er fremstillet af f.eks. gummi eller et polymert materiale eller metal, og som er indrettet til at skrabe skindet, og hvor sættet af skrabeplader (SF) er anbragt nedstrøms for, dvs. efter den anden skrabeenhed (SU2) set i stokkens (M) fremadgående bevægelsesretning.
- 5
4. Apparat ifølge et hvilket som helst af de foregående krav, omfattende en stokunderstøtning (MS), såsom en rulle, der tjener til at støtte stokken (M) i en horisontal retning for nedsættelse af stokkens (M) bøjning ved den mindst ene skraberulles (S2\_1) indgreb.
- 10
5. Apparat ifølge krav 4, hvor stokunderstøtningen (MS) omfatter en rulle, der er indrettet til at støtte stokken (M), og hvor rullen er anbragt mellem stokkens (M) basis og den første skrabeenhed (SU1)
6. Apparat ifølge krav 4 eller 5, hvor stokunderstøtningen (MS) har en fast position i stokkens (M) længderetning.
- 15
7. Apparat ifølge krav 4 eller 5, hvor stokunderstøtningen (MS) er monteret til at være bevægelig i stokkens (M) længderetning, såsom bevægelig sammen med stokkens (M) bevægelse.
8. Apparat ifølge et hvilket som helst af de foregående krav, hvor den første skrabeenhed (SU1)
- 20
- omfatter et sæt horisontale skraberuller (S1\_1, S2\_1) og et sæt vertikale skraberuller (S3\_1).
9. Apparat ifølge krav 8, hvor den anden skrabeenhed (SU2) omfatter et sæt horisontale skraberuller (S2\_2, S3\_2) og et sæt vertikale skraberuller (S1\_2).
- 25
10. Apparat ifølge krav 9, hvor den anden skrabeenheds (SU2) horisontale skraberuller (S2\_2, S3\_2) er anbragt før den anden skrabeenheds (SU2) vertikale skraberuller (S1\_2) set i stokkens (M) fremadgående bevægelsesretning.
- 30
11. Apparat ifølge et hvilket som helst af de foregående krav, hvor den anden skrabeenheds (SU2) skraberuller er af en anden type end den første skrabeenheds (SU1) skraberuller.
12. Apparat ifølge et hvilket som helst af de foregående krav, hvor stokken (M) har rektangulært tværsnit, i det mindste ved dens forreste del, hvor stokken (M) er indrettet for anbringelse af skindet.

13. Apparat ifølge et hvilket som helst af de foregående krav, omfattende et klemmearrangement, der er indrettet for fastklemning af en hoved- eller en snudedel af skindet til stokken (M) under skrabning.

5 14. Fremgangsmåde til skrabning af et skind, såsom et minkskind, hvilken fremgangsmåde omfatter

- at anbringe skindet på en stok (M) med hårsiden vendende indad,

10 - at bevæge stokken fremad i dens længderetning for at skrabe skindet med en første skrabeenhed (SU1), som har en flerhed af første roterende skraberuller (S1\_1, S2\_1, S3\_1) og en flerhed af skrabeplader (SF), der er anbragt efter, dvs. nedstrøms de første roterende skraberuller set i stokkens (M) fremadgående bevægelsesretning,

- at sprøjte en mængde væske (L) på de respektive skraberuller (S1\_1, S2\_1, S3\_1) hørende til den første skrabeenhed (SU1),

15 - hvor sprøjtedyserne (N) er anbragt og indrettet på den side af de respektive skraberuller (S1\_1, S2\_1, S3\_1), der er opstrøms i forhold til skraberulletændernes kontakt (C) med skindet, for at sprøjte væske på skraberulletænderne umiddelbart før de kommer i kontakt med skindet,

- hvilken væske har en temperatur mellem 30 og 90 °C, såsom mellem 40 og 85 °C, såsom mellem 50 og 80 °C, når den sprøjtes på de respektive skraberuller,

20 - at bevæge stokken yderligere fremad for skrabning af skindet med den anden skrabeenhed (SU2) med en flerhed af anden roterende skraberuller og en flerhed af skrabeplader, der er anbragt efter, dvs. nedstrøms for den anden flerhed af roterende skraberuller set i stokkens fremadgående bevægelsesretning,

25 - at sprøjte en mængde væske (L) på de respektive skraberuller (S2\_1, S2\_2, S2\_3) hørende til den anden skrabeenhed (SU2),

- hvor sprøjtedyserne (N) er anbragt og indrettet på den side af de respektive skraberuller, der er opstrøms i forhold til skraberulletændernes kontakt (C) med skindet, for at sprøjte væske på skraberulletænderne, umiddelbart før de kommer i kontakt med skindet,

30 - hvilken væske har en temperatur mellem 30 og 90 °C, såsom mellem 40 og 85 °C, såsom mellem 50 og 80 °C, når den sprøjtes på de respektive skraberuller, og hvor den første og anden skrabeenheds (SU1, SU2) skraberuller (S1\_1, S2\_1, S3\_1; S2\_1, S2\_2, S3\_2) arbejder i fravær af ethvert partikelformet materiale, såsom savsmuld.

35

# DRAWINGS

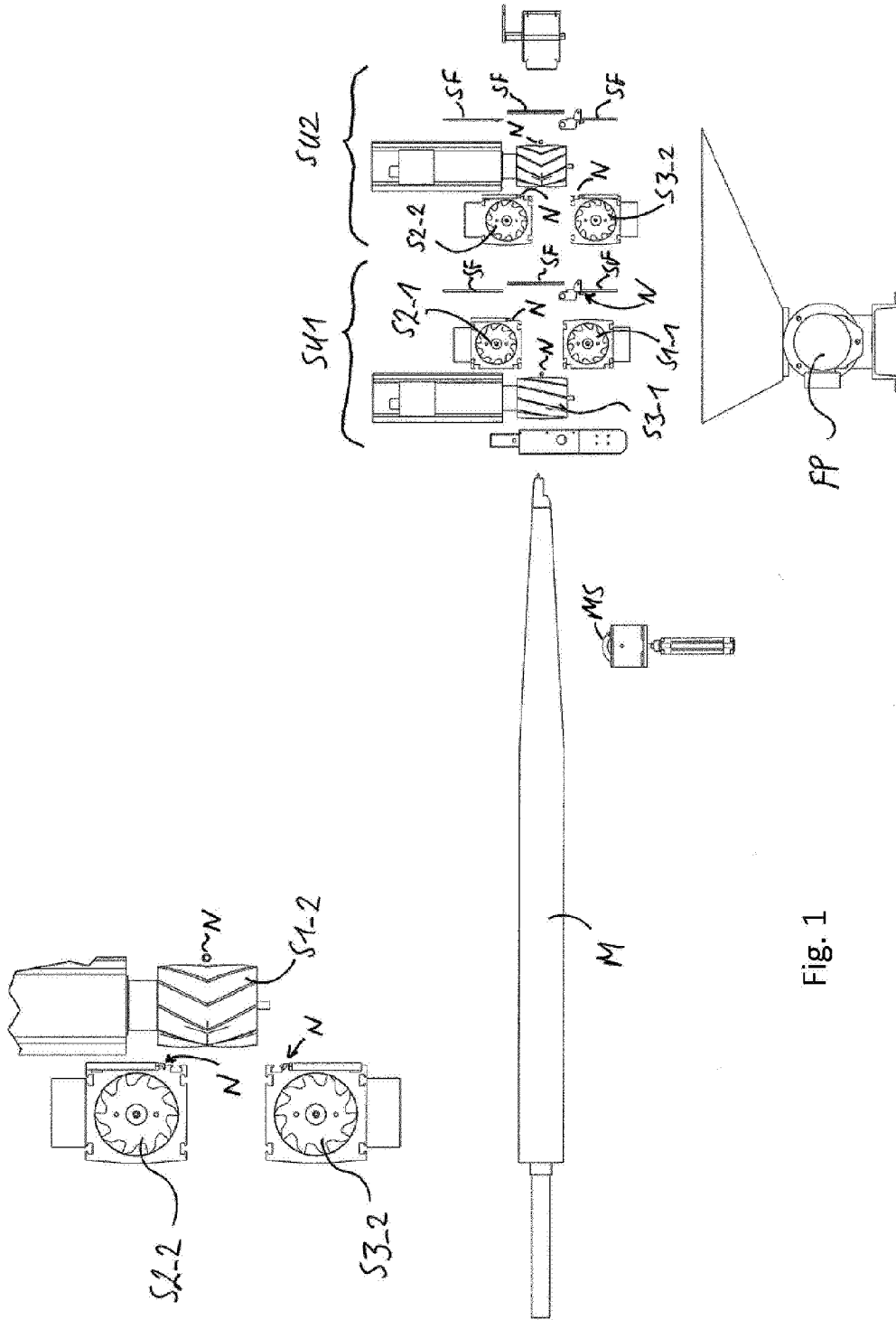

Fig. 1

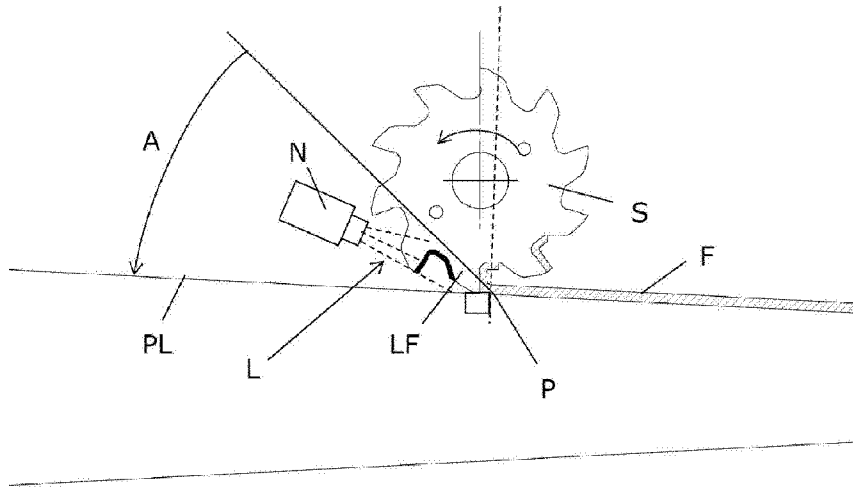

Fig. 2

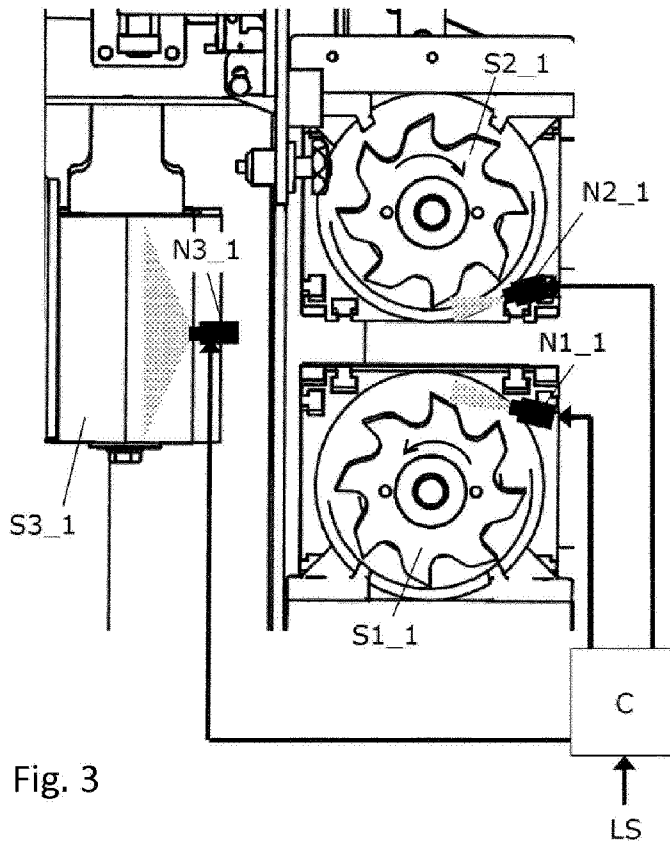

Fig. 3

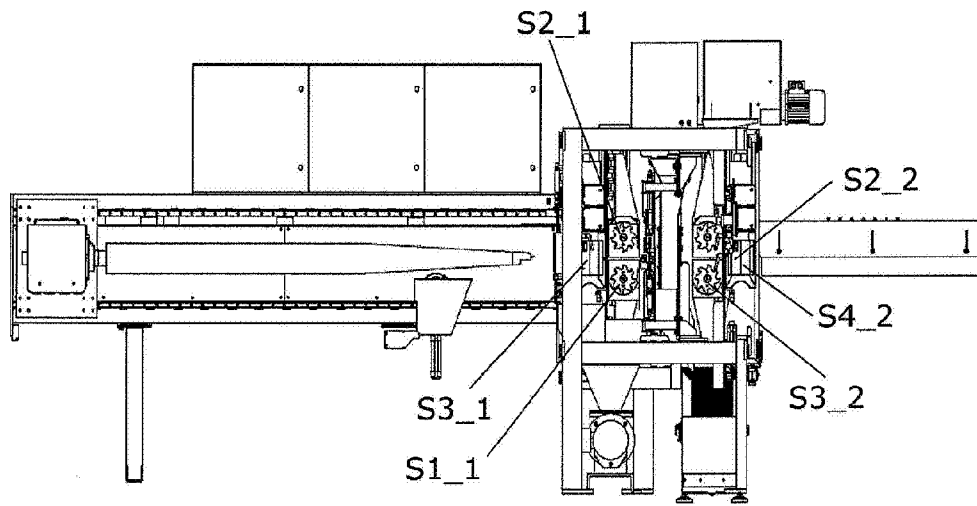

Fig. 4