



(51) International Patent Classification:

A24B 15/16 (2006.01) A24F 47/00 (2006.01)

(21) International Application Number:

PCT/EP2019/061151

(22) International Filing Date:

01 May 2019 (01.05.2019)

(25) Filing Language:

English

(26) Publication Language:

English

(30) Priority Data:

1807170.4 01 May 2018 (01.05.2018) GB

(71) Applicant: **NERUDIA LIMITED** [GB/GB]; Wellington House, Physics Road, Speke, Liverpool Merseyside L24 9HP (GB).

(72) Inventors: **JASINSKI, Krystian**; C/O Nerudia Limited, Wellington House, Physics Road, Speke, Liverpool Merseyside L24 9HP (GB). **JONES, David**; C/O Nerudia Limited, Wellington House, Physics Road, Speke, Liverpool Merseyside L24 9HP (GB).

(74) Agent: **MEWBURN ELLIS LLP**; City Tower, 40 Basinghall Street, London Greater London EC2V 5DE (GB).

(81) Designated States (unless otherwise indicated, for every kind of national protection available): AE, AG, AL, AM, AO, AT, AU, AZ, BA, BB, BG, BH, BN, BR, BW, BY, BZ,

CA, CH, CL, CN, CO, CR, CU, CZ, DE, DJ, DK, DM, DO, DZ, EC, EE, EG, ES, FI, GB, GD, GE, GH, GM, GT, HN, HR, HU, ID, IL, IN, IR, IS, JO, JP, KE, KG, KH, KN, KP, KR, KW, KZ, LA, LC, LK, LR, LS, LU, LY, MA, MD, ME, MG, MK, MN, MW, MX, MY, MZ, NA, NG, NI, NO, NZ, OM, PA, PE, PG, PH, PL, PT, QA, RO, RS, RU, RW, SA, SC, SD, SE, SG, SK, SL, SM, ST, SV, SY, TH, TJ, TM, TN, TR, TT, TZ, UA, UG, US, UZ, VC, VN, ZA, ZM, ZW.

(84) Designated States (unless otherwise indicated, for every kind of regional protection available): ARIPO (BW, GH, GM, KE, LR, LS, MW, MZ, NA, RW, SD, SL, ST, SZ, TZ, UG, ZM, ZW), Eurasian (AM, AZ, BY, KG, KZ, RU, TJ, TM), European (AL, AT, BE, BG, CH, CY, CZ, DE, DK, EE, ES, FI, FR, GB, GR, HR, HU, IE, IS, IT, LT, LU, LV, MC, MK, MT, NL, NO, PL, PT, RO, RS, SE, SI, SK, SM, TR), OAPI (BF, BJ, CF, CG, CI, CM, GA, GN, GQ, GW, KM, ML, MR, NE, SN, TD, TG).

Declarations under Rule 4.17:

— of inventorship (Rule 4.17(iv))

Published:

— with international search report (Art. 21(3))

(54) Title: SMOKING SUBSTITUTE SYSTEM

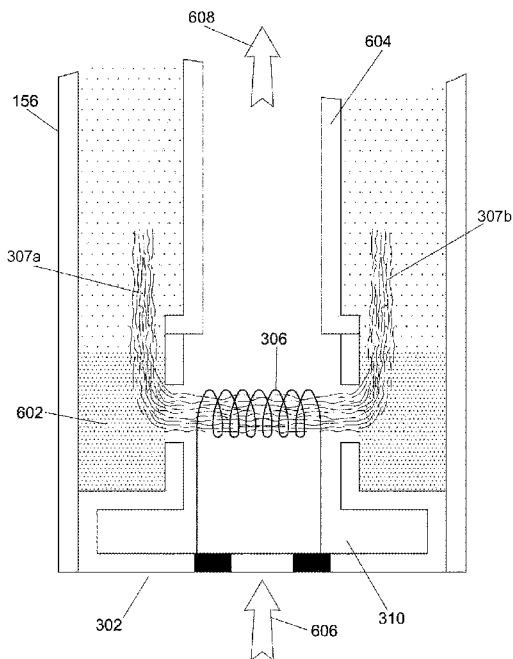

Fig. 5

(57) Abstract: A consumable for a smoking substitute device contains a liquid aerosol-forming substrate, wherein the substrate comprises solid tobacco-derived material and a solution of nicotine which has been released from the tobacco-derived material. The substrate can be a suspension of solids in a solution of nicotine obtained from nicotine-free liquid. The solids may be obtained from tobacco plant having an inherently high content of nicotine of at least 4% by weight. The nicotine-containing solution may comprise propylene glycol and glycerine in a ratio within the range of 10:90 to 90:10. The solution is obtained by extracting nicotine from the solid under conditions of elevated temperature and / or agitation. The tobacco-derived material may have a maximum dimension in a range of 20µm to 2000µm. Tobacco-derived solid may be visible in the substrate to identify the nicotine in the solution as being derived from tobacco.



SMOKING SUBSTITUTE SYSTEM

Field of the Invention

The present invention relates to smoking substitute systems, a consumable containing a liquid aerosol-forming substrate and methods for manufacture thereof.

5 *Background*

Smoking substitute devices, which may also be known as electronic nicotine delivery systems, may comprise electronic systems that permit a user to simulate the act of smoking by producing an aerosol, also referred to as a “vapour”, which is drawn into the lungs through the mouth (inhaled) and then exhaled. The inhaled aerosol typically bears nicotine
10 and/or flavourings without, or with fewer of, the odour and health risks associated with traditional smoking.

In general, smoking substitute devices are intended to provide a substitute for the rituals of smoking, whilst providing the user with a similar experience and satisfaction to those experienced with traditional smoking and tobacco products.

15 The popularity and use of smoking substitute devices has grown rapidly in the past few years. Although originally marketed as an aid to assist habitual smokers wishing to quit tobacco smoking, consumers are increasingly viewing smoking substitute devices as desirable lifestyle accessories. Some smoking substitute devices are designed to resemble a traditional cigarette and are cylindrical in form with a mouthpiece at one end. Other smoking
20 substitute devices do not generally resemble a cigarette (for example, the smoking substitute device may have a generally box-like form).

There are a number of different categories of smoking substitute devices, each utilising a different smoking substitute approach.

One approach for a smoking substitute device is the so-called “vaping” approach, in which a
25 vapourisable liquid, typically referred to as “e-liquid”, is heated by a heating device to produce an aerosol vapour which is inhaled by a user. An e-liquid typically includes a base liquid as well as nicotine and/or flavourings. The resulting vapour therefore typically contains nicotine and/or flavourings. The base liquid may include propylene glycol and/or vegetable glycerine.

A typical vaping smoking substitute device includes a mouthpiece, a power source (typically
30 a battery), a tank for containing e-liquid, as well as a heating device. In use, electrical energy

is supplied from the power source to the heating device, which heats the e-liquid to produce an aerosol (or “vapour”) which is inhaled by a user through the mouthpiece.

Vaping smoking substitute devices can be configured in a variety of ways. For example, there are “closed system” vaping smoking substitute devices which typically have a sealed
5 tank and heating element which is pre-filled with e-liquid and is not intended to be refilled by an end user. One subset of closed system vaping smoking substitute devices include a main body which includes the power source, wherein the main body is configured to be physically and electrically coupled to a consumable including the tank and the heating element. In this way, when the tank of a consumable has been emptied, the main body can be reused by
10 connecting it to a new consumable. Another subset of closed system vaping smoking substitute devices are completely disposable, and intended for one-use only.

There are also “open system” vaping smoking substitute devices which typically have a tank that is configured to be refilled by a user, so the device can be used multiple times.

An example vaping smoking substitute device is the myblu™ e-cigarette. The myblu™
15 e-cigarette is a closed system device which includes a main body and a consumable. The main body and consumable are physically and electrically coupled together by pushing the consumable into the main body. The main body includes a rechargeable battery. The consumable includes a mouthpiece, a sealed tank which contains e-liquid, as well as a heating device, which for this device is a heating filament coiled around a portion of a wick
20 which is partially immersed in the e-liquid. The device is activated when a microprocessor on board the main body detects a user inhaling through the mouthpiece. When the device is activated, electrical energy is supplied from the power source to the heating device, which heats e-liquid from the tank to produce a vapour which is inhaled by a user through the mouthpiece.

25 Another example vaping smoking substitute device is the blu PRO™ e-cigarette. The blu PRO™ e-cigarette is an open system device which includes a main body, a (refillable) tank, and a mouthpiece. The main body and tank are physically and electrically coupled together by screwing one to the other. The mouthpiece and refillable tank are physically coupled together by screwing one into the other, and detaching the mouthpiece from the refillable
30 tank allows the tank to be refilled with e-liquid. The device is activated by a button on the main body. When the device is activated, electrical energy is supplied from the power source to a heating device, which heats e-liquid from the tank to produce a vapour which is inhaled by a user through the mouthpiece.

Another approach for a smoking substitute device is the so-called "heat not burn" ("HNB") approach in which tobacco (rather than e-liquid) is heated or warmed to release vapour. The tobacco may be leaf tobacco or reconstituted tobacco. The vapour may contain nicotine and/or flavourings. In the HNB approach the intention is that the tobacco is heated but not
5 burned, i.e. does not undergo combustion.

A typical HNB smoking substitute device may include a main body and a consumable. The consumable may include the tobacco material. The main body and consumable may be configured to be physically coupled together. In use, heat may be imparted to the solid tobacco material by a heating device that is typically located in the main body, wherein
10 airflow through the tobacco material causes moisture in the tobacco material to be released as vapour. A vapour may be formed from a carrier in the tobacco material (this carrier may for example include propylene glycol and/or vegetable glycerin) and additionally volatile compounds released from the tobacco. The released vapour may be entrained in the airflow drawn through the tobacco.

15 As the vapour passes through the smoking substitute device (entrained in the airflow) from an inlet to a mouthpiece (outlet), the vapour cools and condenses to form an aerosol (also referred to as a vapour) for inhalation by the user. The aerosol will normally contain the volatile compounds.

An example of the HNB approach is the IQOS® smoking substitute device from Philip Morris
20 Ltd. The IQOS® smoking substitute device uses a consumable, including reconstituted tobacco located in a wrapper. The consumable includes a holder incorporating a mouthpiece. The consumable may be inserted into a main body that includes a heating device. The heating device has a thermally conductive heating knife which penetrates the reconstituted tobacco of the consumable, when the consumable is inserted into the heating
25 device. Activation of the heating device heats the heating element (in this case a heating knife), which, in turn, heats the tobacco in the consumable. The heating of the tobacco causes it to release nicotine vapour and flavourings which may be drawn through the mouthpiece by the user through inhalation.

A second example of the HNB approach is the device known as "Glo"® from British
30 American Tobacco p.l.c. Glo® comprises a relatively thin consumable. The consumable includes leaf tobacco which is heated by a heating device located in a main body. When the consumable is placed in the main body, the tobacco is surrounded by a heating element of the heating device. Activation of the heating device heats the heating element, which, in turn,

heats the tobacco in the consumable. The heating of the tobacco causes it to release nicotine vapour and flavourings which may be drawn through the consumable by the user through inhalation. The tobacco, when heated by the heating device, is configured to produce vapour when heated rather than when burned (as in a smoking apparatus, e.g. a cigarette). The tobacco may contain high levels of aerosol formers (carrier), such as vegetable glycerine ("VG") or propylene glycol ("PG").

Examples of tobacco sachets for use in a tobacco vaporiser are provided in WO2016/096927 (Philip Morris Products S.A.) and WO2016/171997 (Paul Viriyapanthu). In contrast to such approaches, the present invention concerns vaping smoking substitute systems which employ e-liquid substrates.

A host of e-liquid formulations are commercially available for use in vaping smoking substitute devices. The formulations are typically based on vegetable glycerine or propylene glycol in combination with various flavourings. E-liquids may optionally contain nicotine.

Generally e-liquids do not contain solid material as this can interfere with the capillary action of the wick and cause problems with clogging. There have been prior proposals for enabling a consumer to infuse base liquid with solid material in order to customise the flavour of the e-liquid. However, the intention is that solid material is removed prior to supplying the e-liquid to a device for vaporization.

Although vaping smoking substitute devices are gaining popularity in many parts of the world, they are not universally acceptable for use and in a significant number of countries the sale or supply of nicotine-containing e-liquids is restricted. This may be due to the fact that in many countries purified nicotine is classified as a pharmaceutical product and for this reason the sale and use of nicotine-containing liquids is highly regulated. Such countries may in fact prohibit the sale of nicotine-containing e-liquids.

In some countries vaping smoking devices are considered to be drug delivery devices and consequently their use and / or sale may also be prohibited.

It would be desirable to provide a vaping smoking substitute device and system which can be used to deliver an aerosol containing a nicotine component and which would be acceptable for sale and use in countries which currently do not permit the sale and use of purified nicotine-containing e-liquids due to their classification as drugs or pharmaceutical products.

In particular, it would also be highly desirable to provide a vaping smoking substitute system which does not require the consumer to purchase a purified nicotine-containing liquid. It would also be desirable to provide a vaping smoking substitute system which does not require the consumer to handle a purified nicotine-containing liquid.

5 **Summary of the Invention**

The present invention provides a consumable which includes a nicotine-containing liquid aerosol-forming substrate (e-liquid) in which the nicotine is clearly tobacco-derived and as such would not necessarily be classified as a pharmaceutical product.

Accordingly, in a first aspect the invention provides a consumable for a smoking substitute
10 device which contains a liquid aerosol-forming substrate, wherein the liquid aerosol-forming substrate is a suspension of solid tobacco-derived material in a nicotine-containing solution obtained by extracting nicotine from the solid tobacco-derived material under conditions of elevated temperature and / or agitation.

A second aspect of the invention provides a consumable for a smoking substitute device
15 which contains a liquid aerosol-forming substrate, wherein the liquid aerosol-forming substrate is a suspension of solid tobacco-derived material in a nicotine-containing solution obtained from nicotine-free liquids.

A third aspect of the invention provides a consumable for a smoking substitute device which
20 contains a liquid aerosol-forming substrate, wherein the liquid aerosol-forming substrate comprises a tobacco-infused liquid which contains solid tobacco-derived material derived from a tobacco plant having a dry nicotine content of at least 4% by weight.

A fourth aspect of the invention provides a consumable for a smoking substitute device
25 which contains a liquid aerosol-forming substrate, wherein the liquid aerosol-forming substrate contains solid tobacco-derived material suspended in a nicotine-containing solution which comprises propylene glycol and glycerine in a ratio within the range of 10:90 to 90:10 by volume.

A fifth aspect of the invention provides a consumable for a smoking substitute device which
contains a liquid aerosol-forming substrate, wherein the liquid aerosol-forming substrate comprises solid tobacco-derived material and a solution of nicotine released therefrom.

A sixth aspect of the invention provides a consumable for a smoking substitute device which contains a liquid aerosol-forming substrate, wherein the liquid aerosol-forming substrate is a suspension of solid tobacco-derived material in a nicotine-containing solution, wherein the tobacco-derived material solids have a size in a range of 20µm to 2000µm.

- 5 Embodiments of the invention, which apply to any of the first to sixth aspects of the invention are also discussed below.

The liquid aerosol-forming substrate may comprise a suspension of solid tobacco-derived material in which the liquid component contains nicotine which has been released from the solid. The tobacco-derived solids may float, sink or be suspended in the liquid.

- 10 Preferably the solid tobacco-derived material is visible in the substrate, such that this identifies the nicotine as being obtained from a tobacco source. Preferably the solid tobacco-derived material is visible in the consumable. Preferably the solid tobacco-derived material is visible in the smoking substitute device.

- Typically the liquid aerosol-forming substrate may contain at least 20 mg of solid tobacco-derived material per ml of total liquid components. The total amount of solid may be adjusted in dependence upon the concentration of nicotine required in the substrate. Preferably the liquid aerosol-forming substrate contains at least 25 mg, more preferably at least 30 mg, still more preferably 35 mg and especially at least 40 mg of solid tobacco-derived material per ml of total liquid. Optionally this may correspond to the total amount of solid in the aerosol-forming substrate, such that the substrate is substantially free of solid materials which are not derived from tobacco, such as solids intended solely for flavouring.
- 15
20

- Since an aim of the invention is to provide a nicotine-containing solution as a component of the liquid aerosol-forming substrate, the amount of tobacco-derived solid material in the substrate may be greater than that required simply for providing aroma or flavouring to the substrate.
- 25

- Conveniently the liquid aerosol-forming substrate may contain up to 130 mg or up to 125 mg of solid tobacco-derived material per ml of total liquid. Preferably the liquid aerosol-forming substrate contains up to 120 mg or 115 mg, more preferably at up to 110 mg, further preferably up to 105 mg and especially up to 100 mg of solid tobacco-derived material per ml of total liquid.
- 30

Preferably the liquid aerosol-forming substrate may contain 0.1 to 20% by weight of solid material, especially of the tobacco-derived solid material. Often the liquid aerosol-forming

substrate may contain at least 1% by weight, preferably at least 2% by weight, more preferably at least 3% and especially at least 4% by weight. In some embodiments the aerosol-forming substrate may contain up to 19% or 18% by weight of solid material, preferably up to 17 % or 16% and more preferably up to 15% by weight of solid material.

- 5 Suitably the liquid aerosol-forming substrate may contain at least 1.0 mg / ml of nicotine. Often the liquid aerosol-forming substrate may contain at least 1.5mg / ml, preferably at least 1.8 mg / ml, more preferably at least 2.0 mg / ml. Some embodiments may contain at least 2.5 mg / ml, preferably at least 2.8 mg / ml of nicotine, more preferably at least 3.0 mg, most preferably at least 3.2 mg and especially at least 3.5 mg of nicotine per ml of total liquid. The amount of nicotine present can be determined by HPLC methods as known in this technical field.

Typically the maximum amount of nicotine in the liquid aerosol-forming substrate would be 7.0 mg / ml, preferably 6.5 mg / ml, more preferably 6.0 mg / ml, and further preferably 5.5 mg / ml. The nicotine may be in the form of the free base or a salt.

- 15 The liquid component of the aerosol-forming substrate may comprise one or more aerosol formers, optionally together with flavourings. In embodiments of the invention it is preferred that flavourings are in liquid form.

In many aspects of the invention it is not necessary to include extracts of purified nicotine in the substrate. The aim may be to include only nicotine obtained released from tobacco-derived material. In this regard, in many embodiments it is preferred that any nicotine components in the aerosol-forming substrate are tobacco-derived and thus the substrate is substantially free of purified nicotine extracts.

Thus, it is preferred that the nicotine-containing solution in the aerosol-forming substrate is obtained from nicotine-free base liquids. Preferred liquid "base" starting materials include polyols or polyhydric alcohols, optionally together with water. Preferred liquid "base" starting materials include one or more selected from propylene glycol, glycerine and water.

Preferably the liquid component of the aerosol-forming substrate includes at least polypropylene glycol and glycerine. Such combinations have been found to be advantageous in order to achieve good dispersion of solid material throughout the liquid component, together with a liquid component having a density which is less likely to result in leakages from the consumable.

In preferred embodiments the liquid component comprises propylene glycol and glycerine in a ratio within the range of 10:90 to 90:10 by volume, preferably 20:80 to 80:20, more preferably 25:75 to 75: 25, more preferably 30:70 to 70:30, and most preferably 40:60 to 60:40 by volume.

- 5 Preferably the liquid component comprises propylene glycol and glycerine in a ratio within the range of 10:90 to 90:10 by weight, preferably 20:80 to 80:20, more preferably 25:75 to 75: 25, more preferably 30:70 to 70:30, and most preferably 40:60 to 60:40 by weight.

The liquid component may optionally contain water or it may be essentially free of water. In cases where water is included, it is preferred that the substrate contains 0.1 to 10%,
10 preferably 0.1 to 7%, more preferably up to 6%, further preferably up to 5%, more preferably up to 4% and especially up to 3% water, by volume and / or by weight. Water may be introduced as part of a flavouring component.

Particularly preferred aerosol-forming substrates contain up to 70% by weight, more preferably up to 65% and especially up to 60% by weight of propylene glycol. Preferably the
15 substrates contain at least 25% and more preferably at least 30% by weight of propylene glycol.

Particularly preferred aerosol-forming substrates contain up to 70% by weight, more preferably up to 65% and especially up to 60% by weight of glycerine. Preferably the substrates contain at least 25% and more preferably at least 30% by weight of glycerine.

- 20 Preferably a glycerine component is vegetable glycerine.

The tobacco-derived material can take various forms. It may optionally be in the form of tobacco leaf, tobacco stem, tobacco powder and tobacco dust, for example. The tobacco-derived material may be treated to various process conditions prior to being combined with base liquids. For example it may be washed and dehydrated, optionally by freeze drying.

- 25 It is advantageous to select tobacco-derived material from a tobacco plant which has a naturally occurring high nicotine level in order to produce a liquid aerosol-forming substrate which has an effective concentration of nicotine. Preferably the liquid aerosol-forming substrate comprises a tobacco-infused liquid which contains solid tobacco-derived material obtained from a tobacco plant having a nicotine content of at least 3%, especially 3.5 or 4%
30 by weight, preferably at least 4.5%, more preferably at least 5% by weight, still more preferably at least 5.5% by weight and most preferably at least 6% by weight. Conveniently the tobacco plant may have a nicotine content of up to 8 wt %, especially up to 7.5 wt %.

Preferably the tobacco-derived material is finely ground or milled to form a dust or powder. Preferably the tobacco-derived material has a maximum dimension of less than 2000µm such that the material will pass through a sieve having a mesh opening of 2000µm. This may provide an efficient ratio of surface area to liquid in order to achieve effective release of nicotine. Preferably the material has a maximum dimension of no more than 1500µm, more preferably no more than 1200µm such that the material will pass through a sieve having a mesh opening of 1200µm.

Preferably very small tobacco-derived solids are avoided as they are more likely to cause problems with clogging of the wick to the heating device or even be small enough to be released with the vapour when the consumable is in use. Conveniently the tobacco-derived material may be larger than 20µm, preferably larger than 30µm, more preferably larger than 40µm, even more preferably larger than 50µm, further preferably larger than 60µm and especially larger than 70µm.

Employing tobacco-derived material in the form of a powder or dust increases the surface area of the solid material which enhances the release of nicotine from the solid into a solution. The release of nicotine may also be enhanced by subjecting the tobacco-derived material to elevated conditions of temperature.

An aerosol-forming substrate according to embodiments of the invention may comprise a suspension of solid tobacco-derived material in a nicotine-containing solution obtained by extracting nicotine from the solid tobacco-derived material under conditions of elevated temperature and / or agitation and retaining the tobacco-derived solids to provide a suspension.

Preferably an aerosol-forming substrate is obtained by exposing a suspension of tobacco-derived material and base liquid to a temperature of at least 30°C, more preferably at least 35°C, further preferably at least 40°C, most preferably at least 45°C, and especially at least 50 °C, with or without agitation. Preferably the substrate is obtained by exposing a suspension of the tobacco-derive material and base liquid to a temperature up to 60°C, with or without agitation.

In preferred embodiments agitation may be employed, at room temperature of 21°C, or at an elevated temperature such as any of those described above. Agitation may involve rotating or shaking the mixture of tobacco-derived solid and base liquid at a speed in a range of 50 to

500 rpm, preferably at least 100rpm, more preferably at least 200rpm up to 500 rpm or up to 400 rpm, for example.

The aerosol-forming substrate may be exposed to such conditions of elevated temperature and / or agitation before it is supplied to the consumable, or indeed while it is present in the consumable as part of the manufacturing process. This process aspect of the invention
5 takes place as part of the manufacturing process and it is therefore distinguished from any heating step as part of the vaping process.

Preferably the liquid aerosol-forming substrate is visible to the user when it is in the consumable. This helps to confirm that the nicotine in the solution is a tobacco-derived
10 product and as such would not generally be classified as a pharmaceutical product.

According to some preferred embodiments the consumable forms part of a closed system device. In this regard the liquid aerosol-forming substrate may be stored in sealed tank which is provided with at least part of a vaporization mechanism, for example a heating element. The consumable may be disposable, such that the tank is not intended to be
15 refilled or replaced after use.

Preferably the consumable is a cartomizer. Within the broad class of cartomizers, the consumable may be described as a clearomizer if the liquid storage tank includes a window such that the liquid aerosol-forming substrate is visible to the consumer.

In other embodiments the consumable may be a component of an open system device. For
20 example the liquid aerosol-forming substrate may be stored in a refillable cartridge or in another liquid storage container for supply to a refillable cartridge.

As noted above, in one aspect the present invention is concerned with a consumable for a smoking substitute device which contains a liquid aerosol-forming substrate which contains nicotine which is derived from tobacco, rather than added in the form of a purified nicotine
25 extract. The embodiments described above apply also the second, third, fourth, fifth and sixth aspects of the invention.

A second aspect of the invention provides a consumable for a smoking substitute device which contains a liquid aerosol-forming substrate, wherein the liquid aerosol-forming substrate is a suspension of solid tobacco-derived material in a nicotine-containing solution
30 obtained from nicotine-free base liquids.

A third aspect of the invention provides a consumable for a smoking substitute device which contains a liquid aerosol-forming substrate, wherein the liquid aerosol-forming substrate

comprises a tobacco-infused liquid which contains solid tobacco-derived material derived from a tobacco plant having a dry nicotine content of at least 4% by weight.

5 A fourth aspect of the invention provides a consumable for a smoking substitute device which contains a liquid aerosol-forming substrate, wherein the liquid aerosol-forming substrate contains solid tobacco-derived material suspended in a nicotine-containing solution which comprises propylene glycol and glycerine in a ratio within the range of 10:90 to 90:10 by volume.

10 A fifth aspect of the invention provides a consumable for a smoking substitute device which contains a liquid aerosol-forming substrate, wherein the liquid aerosol-forming substrate is a suspension of solid tobacco-derived material in a nicotine-containing solution obtained by extracting nicotine from the solid tobacco-derived material under conditions of elevated temperature and / or agitation.

15 A sixth aspect of the invention provides a consumable for a smoking substitute device which contains a liquid aerosol-forming substrate, wherein the liquid aerosol-forming substrate is a suspension of solid tobacco-derived material in a nicotine-containing solution, wherein the tobacco-derived material has a size in a range of 20 μ m to 2000 μ m.

The invention also provides methods for preparing a liquid aerosol-forming substrate as defined in any aspect of the present invention.

20 The invention also provides methods for manufacturing a consumable as defined in any aspect of the present invention.

A method for preparing such a liquid aerosol-forming substrate may comprise combining solid tobacco-derived material and aerosol former liquid and subjecting the mixture to process conditions which promote release of nicotine from the tobacco-derived solid into the aerosol former liquid while retaining tobacco-derived solids.

25 A method for manufacturing such a consumable which contains a liquid aerosol-forming substrate may comprise combining solid tobacco-derived material and aerosol former liquid and subjecting the mixture to process conditions which promote release of nicotine from the tobacco-derived solid into the aerosol former liquid. The aerosol former liquid may be substantially nicotine-free.

30 Features of the liquid aerosol-forming substrate as described above may be adopted in such methods. In particular, features of the tobacco-derived solid material, the aerosol former

liquid and the process conditions as described above in relation to the first, second, third, fourth, fifth and sixth aspects of the invention may be employed.

In addition the invention concerns the use of a liquid aerosol-forming substrate as defined in any aspect of the present invention in the manufacture of a consumable for a smoking substitute device.

Further apparatus aspects of the invention concern a consumable for a smoking substitute device adapted for vaping a liquid aerosol-forming substrate as defined in any aspect of the present invention and a vaping smoking substitute device configured for vaping a liquid aerosol-forming substrate as defined in any aspect of the present invention.

More specifically the invention provides a vaping smoking substitute device which employs a wick and is configured for vaping a liquid aerosol-forming substrate as defined in any aspect of the invention. In this regard, difficulties may arise when utilizing vaporisable liquids which comprise a suspension of solid material as clogging of the solids can occur around the wick which can reduce or even cut off contact of the wick with the vaporisable liquid. This may occur when the user inhales from a device in which a coil and wick assembly is at a lowermost point of the tank.

In such a further aspect, the invention may provide a consumable for a smoking substitute device, the consumable comprising:

a tank containing a liquid aerosol-forming substrate as defined in any aspect of the present invention; and

a coil and wick assembly, having a cavity, and an aperture which fluidly connects the cavity to the tank;

wherein the coil and wick assembly comprises:

a coil, within the cavity; and

a wick, which extends from the coil through the aperture and into the tank.

By providing a wick which extends in this manner, the likelihood of it becoming clogged or blocked with the solid tobacco-derived material is significantly reduced.

Optional features of this apparatus aspect of the invention will now be set out. These are applicable singly or in any combination with any aspect of the invention. An example of this apparatus aspect is illustrated in the accompanying drawings and discussed in more detail below.

The wick may extend from the aperture by a distance of at least 5mm. The wick may extend from the aperture by a distance of at least 6mm. The wick may extend from the aperture by a

distance of at least 7mm. The wick may extend from the aperture by a distance of at least 8mm. The wick may extend from the aperture by a distance of at least 9mm. The wick may extend from the aperture by a distance of at least 10mm.

5 The wick may have a length, from one end to the other, of more than 2 cm. The wick may have a length of more than 2.5 cm, or more than 3 cm. The wick may have a length of more than 4 cm.

10 The consumable may include a mouthpiece, and the wick may extend from the aperture in a direction substantially towards the mouthpiece. The mouthpiece may be located at or towards an opposite end of the consumable to the coil and wick assembly. Advantageously, as the mouthpiece is generally the highest point of the consumable, when the consumable is in use, by extending the wick towards it this can help ensure that solid matter settling at the bottom of the consumable does so as away from at least some of the wick.

15 The consumable may include a clip, which fixes a portion of the wick not contained within the coil and wick assembly to or near an exterior part of the coil and wick assembly. By providing such a clip, it can be ensured that the wick is held away from a bottommost part of the coil and wick assembly, and so away from an area where solid matter is likely to settle.

20 The consumable may include an outlet, which is fluidly connected to the coil and wick assembly, and a seal, which seals the outlet to the oil and wick assembly, and to which the clip is attached. The outlet may be referred to as a chimney or airway tube, and acts to draw the vaporised liquid from the coil towards the mouthpiece.

25 The coil and wick assembly may have a second aperture, which fluidly connects the cavity to the tank, and the wick may extend from the coil through both the first aperture and the second aperture into the tank. The second aperture may be on an opposite side of the coil and wick assembly to the first aperture. Such a second aperture, with a corresponding second wick portion, may help ensure that even if the first aperture and first wick portion become clogged some portion of the wick is still exposed to the liquid in the tank.

The clip may fix a second portion of the wick, which extends through the second aperture, to or near a second exterior part of the coil and wick assembly on the opposing side of the coil and wick assembly.

30 Any feature of one aspect of the invention may be applied to other aspects of the invention, in any appropriate combination.

According to the second aspect of the invention described above, the nicotine-containing solution is obtained from nicotine-free liquids, such that the nicotine present in the aerosol-forming substrate is solely tobacco-derived. Some embodiments of the invention, particularly

of the third, fourth, fifth and sixth aspects of the invention may permit the inclusion of purified nicotine extracts in the liquid aerosol-forming substrate. In embodiments of the invention where a purified nicotine extract may be included in the aerosol-forming substrate, this may optionally take the form of a free nicotine salt selected from: nicotine hydrochloride; nicotine dihydrochloride; nicotine monotartrate; nicotine bitartrate; nicotine bitartrate dihydrate; 5 nicotine sulphate; nicotine zinc chloride monohydrate; and nicotine salicylate, for example. Embodiments of the invention will now be described further.

Brief Description of the Drawings

Embodiments of the invention will now be described by way of example with reference to the 10 accompanying drawings in which:

Figure 1(a) shows an example smoking substitute device;

Figure 1(b) shows the main body of the smoking substitute device of Figure 1(a) without the consumable;

15 Figure 1(c) shows the consumable of the smoking substitute device of Figure 1(a) without the main body;

Figure 2(a) is a schematic view of the main body of the smoking substitute device of Figure 1(a);

Figure 2(b) is a schematic view of the consumable of the smoking substitute device of Figure 1(b);

20 Figure 3 is a cross-sectional view of a coil and wick assembly;

Figure 4 is a cross-sectional view of a further coil and wick assembly;

Figure 5 is a cross-sectional view of the coil and wick assembly of Figure 3 as installed in a tank; and

Figure 6 is a photograph of a coil and wick assembly.

Detailed Description and Further Optional Features

Aspects and embodiments of the present invention will now be discussed with reference to the accompanying figures. Further aspects and embodiments will be apparent to those skilled in the art. All documents mentioned in this text are incorporated herein by reference

30 Figure 1(a) shows an example smoking substitute device 110. In this example, the smoking substitute device 110 includes a main body 120 and a consumable 150. The

consumable 150 may alternatively be referred to as a “pod”. The consumable may also be referred to as a cartridge or cartomizer.

In this example, the smoking substitute device 110 is a closed system vaping device, wherein the consumable 150 includes a sealed tank or liquid reservoir 156 and is intended
5 for one-use only.

Figure 1(a) shows the smoking substitute device 110 with the main body 120 physically coupled to the consumable 150.

Figure 1(b) shows the main body 120 of the smoking substitute device 110 without the consumable 150.

10 Figure 1(c) shows the consumable 150 of the smoking substitute device 110 without the main body 120.

The main body 120 and the consumable 150 are configured to be physically coupled together, in this example by pushing the consumable 150 into an aperture in a top end 122 of the main body 120. In other examples, the main body 120 and the consumable could be
15 physically coupled together by screwing one onto the other, or through a bayonet fitting, for example. An optional light 126, e.g. an LED located behind a small translucent cover, is located a bottom end 124 of the main body 120. The light 126 may be configured to illuminate when the smoking substitute device 110 is activated.

The consumable 150 includes a mouthpiece (not shown) at a top end 152 of the consumable
20 150, as well as one or more air inlets (not shown in Fig. 2) so that air can be drawn into the smoking substitute device 110 when a user inhales through the mouthpiece. At a bottom end 154 of the consumable 150, there is located a tank 156 that contains e-liquid. The tank 156 may be a translucent body, for example.

The tank 156 preferably includes a window 158, so that the amount of e-liquid in the tank
25 156 can be visually assessed. The main body 120 includes a slot 128 so that the window 158 of the consumable 150 can be seen whilst the rest of the tank 156 is obscured from view when the consumable 150 is inserted into the aperture in the top end 122 of the main body 120.

The tank 156 may be referred to as a “clearomizer” if it includes a window 158, or more
30 generally a “cartomizer”.

The consumable 150 may identify itself to the main body 120, via an electrical interface, RFID chip, or barcode.

Further features of the apparatus are shown in Figures 2 to 6 and described in more detail below.

- 5 Tank 156 contains a liquid aerosol-forming substrate. The substrate comprises a nicotine-containing solution and solid tobacco-derived material. The substrate is obtained by infusing liquid components with solid tobacco material in order to release nicotine from the solid tobacco material. The substrate is in the form of a suspension of solid material in a nicotine-containing solution. This can identify the substrate as a nicotine-containing solution which is
10 derived from tobacco material.

The liquid components include aerosol formers such as glycerine and propylene glycol. A combination of both glycerine and propylene glycol has been found to be preferred for achieving good dispersion of solid particles in a liquid of an appropriate viscosity to show resistance to leakage from the tank 156. Water may also be included as this has been found
15 to enhance release of nicotine from the tobacco solid. In this respect, water may be incorporated as part of a raw material flavouring formulation or it may be added as a separate raw material. The appropriate amount of water, or any aerosol former, may be adjusted as appropriate for compatibility with different flavour combinations.

The tobacco material is derived from a tobacco plant. It may be prepared from leaf or stem,
20 for example. The tobacco plant is usually ground or powdered to reduce its size so as to increase the surface area available for infusion with liquid and therefore improve the amount of nicotine extracted therefrom. Very small particles are best avoided as they can become entrained with the vapour and be inhaled by the user and this is regarded as unpleasant. Large particle sizes are also more likely to cause problems with clogging of the wick.

25 Tobacco solids having particle sizes in a range of 50 to 2000µm, particularly 100 to 1000µm and especially 250 to 500 µm have provided an excellent combination of efficient release of nicotine together with resistance to clogging of the wick of the consumable.

The tobacco is preferably derived from a plant which inherently has a high nicotine content, in order to maximise the amount of nicotine which can be released in to the solution. A high
30 nicotine content could correspond to at least 4% by weight of the dry plant material. An example of a tobacco product with a high nicotine content is grown in the Philippines and

has a dry content in the leaf of about 7% by weight. The nicotine content can be determined by HPLC methods as known in this technical field.

The liquid components preferably include propylene glycol and glycerine in a ratio in a range of 90:10 to 10:90 by volume. Example liquid components typically contain 0.1 to 50% by volume of propylene glycol and 0.1 to 50% by volume of glycerine. Generally the liquid components would also contain up to 5% or more usually up to 3% by volume of water. Example formulations comprise 45% PG, 45% VG with 10% of water and flavourings; and 50% PG, 45% VG with the balance water and flavourings. Different water contents may be required for compatibility with different flavouring formulations.

10 The mixture of liquid components and ground tobacco may be subjected to heating and / or agitation in order to enhance release of nicotine as part of the process for manufacturing the e-liquid. This preferably involves heating the mixture at a temperature above room temperature and up to 60°C. In experiments elevation of temperature alone from 21° C to 60 °C has been found to result in about a 50% increase in the release of nicotine from the tobacco solid. This heating step is part of the process for manufacturing the liquid aerosol-forming substrate and can therefore be distinguished from a step of heating the liquid as part of the vaping process. The mixture of tobacco-derived solids and base liquids can be heated prior to supply to the tank 156, or a filled tank 156 could be heated in this way.

20 Agitation of the mixture at a speed of at least 100 rpm has also been found to be effective to enhance extraction of nicotine from the tobacco-derived solid. Agitation at 400 rpm for 3 hours has been found to result in an increase in the amount of nicotine released by a factor of over 100%, as compared to simply allowing a corresponding mixture to stand for the same period in order to allow nicotine to infuse into the base liquids, for example. The mixture may be heated and / or agitated prior to supply to the storage tank 156 of the consumable.

25 Alternatively or additionally a storage tank 156 containing a mixture may be heated and / or agitated in order to enhance release of nicotine into the liquid stored in the consumable.

The presence of solid tobacco-derived material in a consumable for a vaping smoking substitute device which employs a wick could cause problems in terms of clogging of the wick. Figures 3 to 6 of the accompanying drawings illustrate modifications to a vaping smoking substitute device in order to alleviate such difficulties.

30 Features of an example smoking substitute device will now be described in more detail.

Figure 2(a) is a schematic view of the main body 120 of the smoking substitute device 110.

Figure 2(b) is a schematic view of the consumable 150 of the smoking substitute device 110.

As shown in Figure 2(a), the main body 120 includes a power source 140, a control unit 130, a memory 132, a wireless interface 134, an electrical interface 136, and, optionally, one or
5 more additional components 138.

The power source 140 is preferably a battery, more preferably a rechargeable battery.

The control unit 130 may include a microprocessor, for example.

The memory 132 is preferably includes non-volatile memory. The memory may include instructions which, when implemented, cause the control unit 130 to perform certain tasks or
10 steps of a method.

The wireless interface 134 is preferably configured to communicate wirelessly with the mobile device 2, e.g. via Bluetooth®. To this end, the wireless interface 134 could include a Bluetooth® antenna. Other wireless communication interfaces, e.g. WiFi®, are also possible. As discussed above, the wireless interface 134 may be configured to communicate
15 wirelessly with the remote server 2.

The electrical interface 136 of the main body 120 may include one or more electrical contacts. The electrical interface 136 may be located in, and preferably at the bottom of, the aperture in the top end 122 of the main body 120. When the main body 120 is physically coupled to the consumable 150, the electrical interface 136 may be configured to pass
20 electrical power from the power source 140 to (e.g. a heating device of) the consumable 150 when the smoking substitute device 110 is activated, e.g. via the electrical interface 160 of the consumable 150 (discussed below). When the main body 120 is not physically coupled to the consumable 150, the electrical interface may be configured to receive power from the charging station 6. The electrical interface 136 may also be used to identify the consumable
25 150 from a list of known consumables. For example, the consumable may be a particular flavour and/or have a certain concentration of nicotine. This can be identified to the control unit 130 of the main body 120 when the consumable is connected to the main body.

Additionally, or alternatively, there may be a separate communication interface provided in the main body 120 and a corresponding communication interface in the consumable 150
30 such that, when connected, the consumable can identify itself to the main body 120.

The additional components 138 of the main body 120 may include the optional light 126 discussed above.

The additional components 138 of the main body 120 may, if the power source 140 is a rechargeable battery, include a charging port configured to receive power from the charging station 6. This may be located at the bottom end 124 of the main body 120. Alternatively, the electrical interface 136 discussed above is configured to act as a charging port configured to receive power from the charging station 6 such that a separate charging port is not required.

The additional components 138 of the main body 120 may, if the power source 140 is a rechargeable battery, include a battery charging control circuit, for controlling the charging of the rechargeable battery. However, a battery charging control circuit could equally be located in the charging station 6 (if present).

The additional components 138 of the main body 120 may include an airflow sensor for detecting airflow in the smoking substitute device 110, e.g. caused by a user inhaling through a mouthpiece 166 (discussed below) of the smoking substitute device 110. The smoking substitute device 110 may be configured to be activated when airflow is detected by the airflow sensor. This optional sensor could alternatively be included in the consumable 150 (though this is less preferred where the consumable 150 is intended to be disposed of after use, as in this example). The airflow sensor can be used to determine, for example, how heavily a user draws on the mouthpiece or how many times a user draws on the mouthpiece in a particular time period.

The additional components 138 of the main body 120 may include an actuator, e.g. a button. The smoking substitute device 110 may be configured to be activated when the actuator is actuated. This provides an alternative to the airflow sensor noted, as a mechanism for activating the smoking substitute device 110.

As shown in Figure 2(b), the consumable 150 includes the tank 156 for the liquid aerosol-forming substrate (e-liquid), an electrical interface 160, a heating device 162, one or more air inlets 164, a mouthpiece 166, and, optionally, one or more additional components 168.

The electrical interface 160 of the consumable 150 may include one or more electrical contacts. The electrical interface 136 of the main body 120 and an electrical interface 160 of the consumable 150 are preferably configured to contact each other and therefore electrically couple the main body 120 to the consumable 150 when the main body 120 is physically coupled to the consumable 150. In this way, electrical energy (e.g. in the form of an electrical current) is able to be supplied from the power source 140 in the main body 120 to the heating device 162 in the consumable 150.

The heating device 162 is preferably configured to heat e-liquid contained in the tank 156, e.g. using electrical energy supplied from the power source 140. In one example, the heating device 162 may include a heating filament and a wick, wherein a first portion of the wick extends into the tank 156 in order to draw e-liquid out from the tank 156, and wherein the heating filament coils around a second portion of the wick located outside the tank 156. In this example, the heating filament is configured to heat up e-liquid drawn out of the tank 156 by the wick to produce an aerosol vapour.

The one or more air inlets 164 are preferably configured to allow air to be drawn into the smoking substitute device 110, when a user inhales through the mouthpiece 166.

In use, a user activates the smoking substitute device 110, e.g. through actuating an actuator included in the main body 120 or by inhaling through the mouthpiece 166 as described above. Upon activation, the control unit 130 may supply electrical energy from the power source 140 to the heating device 162 (via electrical interfaces 136, 166), which may cause the heating device 162 to heat e-liquid drawn from the tank 156 to produce a vapour which is inhaled by a user through the mouthpiece 166.

As an example of one of the one or more additional components 168, an interface for obtaining an identifier of the consumable may be provided. As discussed above, this interface may be, for example, an RFID reader, a barcode or QR code reader, or an electronic interface which is able to identify the consumable to the main body. The consumable may, therefore include any one or more of an RFID chip, a barcode or QR code, or memory within which is an identifier and which can be interrogated via the electronic interface in the main body.

Of course, a skilled reader would readily appreciate that the smoking substitute device 110 shown in Figs. 2 and 3 shows just one example implementation of a smoking substitute device, and that other forms of smoking substitute device could be used.

As another example, an open system vaping device which includes a main body, a refillable tank, and a mouthpiece could be used, instead of the smoking substitute device 110. One such open system vaping device is the blu PRO™ e-cigarette discussed above.

As another example, an entirely disposable (one use) smoking substitute device could be used as the smoking substitute device.

Figure 3 shows a cross-sectional view of a coil and wick assembly 302. The coil and wick assembly may form the heater of any of the preceding consumables 150. The coil and wick

assembly is disposed within the tank 156, at a bottom end thereof opposite to the mouthpiece 166. The coil and wick assembly is connected to the mouthpiece via an outlet, or chimney. The coil and wick assembly may form a lower wall of the tank, i.e. it may at least partially define the interior volume of the tank.

5 Broadly, the coil and wick assembly is formed from a housing 304, in which are first 305a and second 305b apertures or wick apertures. Within a cavity 310, provided by the housing, is a coil 306 e.g. coil of electrical wire, connected to first 308a and second 308b electrical contacts. These contacts are connectable to the battery of the main device 110, and so provide power to the coil.

10 An outlet aperture 309 is located proximal to the coil 306. When installed within the consumable, the outlet aperture is sealed from the liquid containing volume of the tank and is fluidly connected to an outlet. The outlet fluidly connects the cavity 310 of the coil and wick assembly to the mouthpiece. A wick 307 is provided through the coil, and through each of the first and second apertures. The wick acts to substantially seal the cavity 310 of the coil and wick assembly from free flowing liquid in the tank. Thus, liquid can only enter the cavity
15 310 by capillary action i.e. by being wicked in via the wick. The wick extends from the apertures, in a direction away from the electrical contacts to leave exposed regions 307a and 307b respectively.

The coil and wick assembly has an outlet aperture 309, which is positioned above the coil
20 i.e. on an opposing side of the coil to the electrical contacts, in an uppermost surface of the coil and wick assembly. This outlet aperture is connected to the outlet discussed previously, which allows vaporised liquid to travel to the mouthpiece. The wick may have a length, as measured from one end to an opposing end, of more than 2 cm. For example, the wick may have a length of around 3 cm.

25 At a lower end of the consumable, i.e. one nearest the electrical contacts, is an air inlet 164. In use, the user draws on the mouthpiece which causes air to flow in through air inlet 164. This airflow draws with it vaporised liquid from the wick contained within the coil 306 (which is heated); and the airflow, now containing vaporised liquid, travels up an outlet and into the mouthpiece whereby it is inhaled. Whilst the air inlet in this example is shown as a single air
30 inlet disposed between the electrical contacts, instead there may be plural air inlets disposed between respective electrical contacts and an edge region of the coil and wick assembly. Further alternatively, there may be a single air inlet which extends across a width of the device thereby defining a channel. The channel may be bridged, across its width, by the first and second electrodes.

Figure 4 shows a variant coil and wick assembly, where like reference numerals denote like features.

A notable difference between Figure 4 and Figure 3 is the inclusion of first 402a and second 402b clips, which are attached to a seal 400. The seal 400 seals an outlet (not shown) to the coil and wick assembly, so that vaporised liquid can pass there between. The first and
5 second clips retain the exposed portions of wick in a position distal from the electrical contacts and proximal to the seal. For clarity, in Figure 4 the outlet aperture 309 is omitted. However it will be appreciated that there is an outlet aperture present which allows the flow of vaporised liquid within the cavity 310 through a portion of the seal 400 and onwards to the
10 outlet. Whilst the clip in this example is attached to the seal, it may be that the clip is attached to an upper region of the coil and wick assembly (i.e. between the aperture and the seal) or to a portion of the outlet. By varying the location of the clip, the consumable is able to accommodate a range of wick lengths.

Figure 5 shows the coil and wick assembly of Figure 3, as installed in the consumable 150.
15 As can be seen, the coil and wick assembly 302 forms a lower wall of the tank 156 and so at least partially defines the liquid containing volume thereof. The tank 156 in this example is filled with an aerosol-forming substrate in the form of a vaporisable liquid which contains a solid suspension. As a result, when the consumable 150 is orientated such that the mouthpiece is higher than the coil and wick assembly (as is the case in Figure 5) solid
20 tobacco-derived sediment 602 may accumulate around the coil and wick assembly. The portions of the wick 307a and 307b extend above where this sediment may accumulate, and so will generally be exposed to the liquid within the tank 156. As shown in the figure, an outlet 604 is provided which is sealed to the coil and wick assembly via a seal (omitted for clarity). Arrows 606 and 608 indicate the air flow through the consumable.

25 Figure 6 is a photograph of a coil and wick assembly similar to that shown in Figure 4. Like features are denoted by like reference numerals.

The clip assembly can be more clearly seen in this view, with a main body 502 positioned around the seal 400. First 402a and second 402b clips extend from the main body on opposing sides of the coil and wick assembly 302.

30 While the invention has been described in conjunction with the exemplary embodiments described above, many equivalent modifications and variations will be apparent to those skilled in the art when given this disclosure. Accordingly, the exemplary embodiments of the invention set forth above are considered to be illustrative and not limiting. Various changes

to the described embodiments may be made without departing from the spirit and scope of the invention.

List of Features

	110	Smoking substitute device
	120	Main body
	122	Top end of main body
5	124	Bottom end of main body
	126	Light
	128	Slot
	130	Control unit
	132	Memory
10	134	Wireless interface
	136	Electrical interface
	138	Additional component
	140	Power source
	150	Consumable
15	152	Top end of consumable
	154	Bottom end of consumable
	156	Tank
	158	Window
	160	Electrical interface
20	162	Heating device
	164	Air inlets
	166	Mouthpiece
	168	Additional components
	302	Coil and wick assembly
25	304	Housing
	305a,b	Apertures
	306	Coil
	307a,b	Wick
	308a,b	Electrical contacts
30	310	Cavity
	400	Seal
	402a,b	Clip
	502	Clip main body
	602	Sediment
35	604	Outlet
	606, 608	Air flow

Claims:

1. A consumable for a smoking substitute device which contains a liquid aerosol-forming substrate, wherein the liquid aerosol-forming substrate is a suspension of solid tobacco-derived material in a nicotine-containing solution obtained by extracting nicotine
5 from the solid tobacco-derived material under conditions of elevated temperature and / or agitation.
2. A consumable according to claim 1 wherein the aerosol-forming substrate is obtained by exposing a combination of tobacco-derived material and base liquid containing at least one aerosol former to a temperature of at least 30°C.
- 10 3. A consumable according to claim 2 wherein the aerosol-forming substrate is obtained by exposing a combination of tobacco-derived material and base liquid containing at least one aerosol former to a temperature of at least 40°C.
4. A consumable according to any preceding claim, wherein the liquid aerosol-forming substrate is obtained by subjecting a combination of tobacco-derived material and base
15 liquid to agitation in order to promote release of nicotine from the tobacco-derived material in to the base liquid.
5. A consumable according to claim 4, wherein the liquid aerosol-forming substrate is obtained by subjecting the combination of tobacco-derived material and base liquid to agitation at a speed of at least 100rpm in order to promote release of nicotine.
- 20 6. A consumable according to any preceding claim, wherein the liquid aerosol-forming substrate is obtained from nicotine-free liquid containing at least one aerosol former.
7. A consumable according to any preceding claim, wherein the liquid aerosol-forming substrate contains at least 2.0 mg/ml of nicotine and preferably contains at least 3.0 mg/ml of nicotine.
- 25 8. A consumable according to any preceding claim, wherein the liquid aerosol-forming substrate contains at least 20 mg of solid tobacco-derived material per ml of liquid.
9. A consumable according to any preceding claim, wherein the liquid aerosol-forming substrate contains up to 130 mg of solid tobacco-derived material per ml of liquid.

10. A consumable according to any preceding claim, wherein the liquid-aerosol forming substrate contains from 0.1 to 20% by weight of solid material.
11. A consumable according to any preceding claim, wherein the liquid aerosol-forming substrate contains solid tobacco-derived material obtained from tobacco leaf and / or tobacco stem.
12. A consumable according to any preceding claim, wherein the liquid aerosol-forming substrate comprises solid tobacco-derived material having a size in a range of 20µm to 2000µm.
13. A consumable according to any preceding claim, wherein the liquid aerosol-forming substrate contains flavourings and / or aroma components which are not derived from tobacco.
14. A consumable according to any preceding claim, in which the liquid aerosol-forming substrate is visible.
15. A consumable according to any one of claims 1 to 14, which forms part of a closed system device in which liquid aerosol-forming substrate is stored in a tank which is not adapted for refilling.
16. A consumable according to any one of claims 1 to 14, which forms part of an open system device in which liquid aerosol-forming substrate is stored in a tank which is adapted for refilling.
17. Use of a liquid aerosol-forming substrate as defined in any one of claims 1 to 13 in the manufacture of a consumable for a smoking substitute device.
18. A method for manufacturing a consumable for a smoking substitute device which contains a liquid aerosol-forming substrate as defined in any one of claims 1 to 16, which method comprises combining solid tobacco-derived material and aerosol former liquid and subjecting the mixture to process conditions of elevated temperature and / or agitation to enhance release of nicotine from the tobacco-derived material into the aerosol former liquid.
19. A vaping smoking substitute device configured for vaping a liquid aerosol-forming substrate as defined in any one of claims 1 to 13.

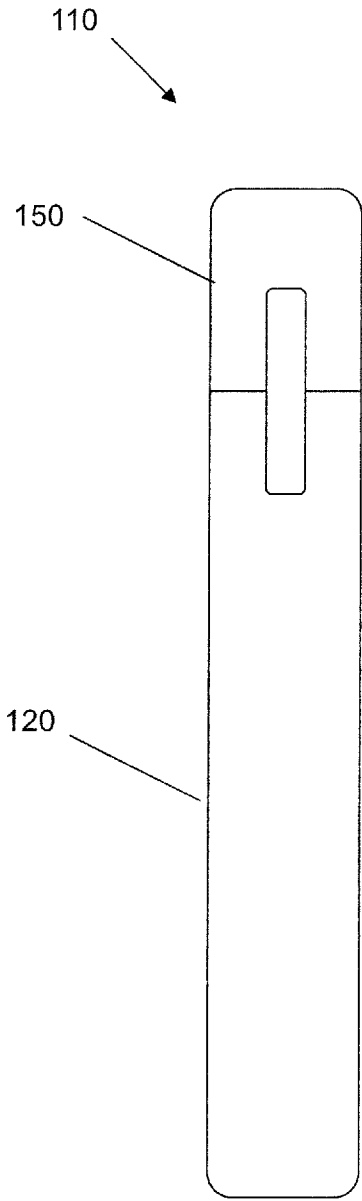

Fig. 1(a)

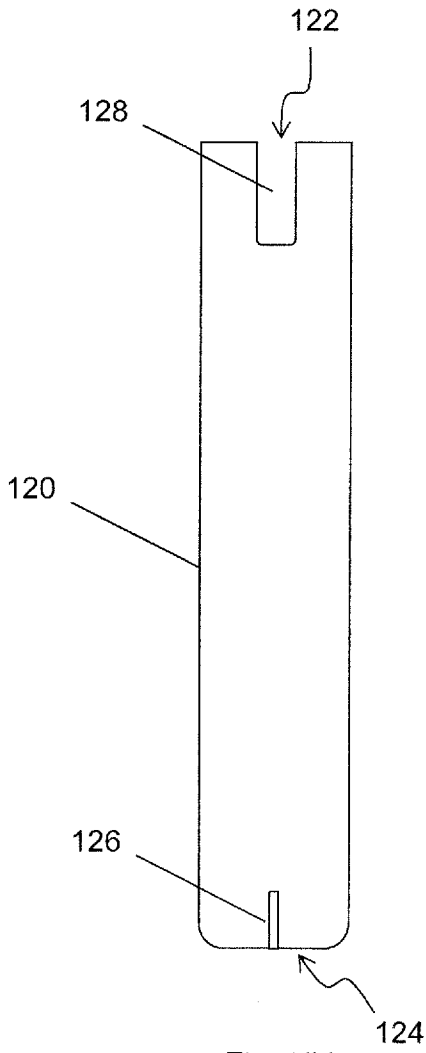

Fig. 1(b)

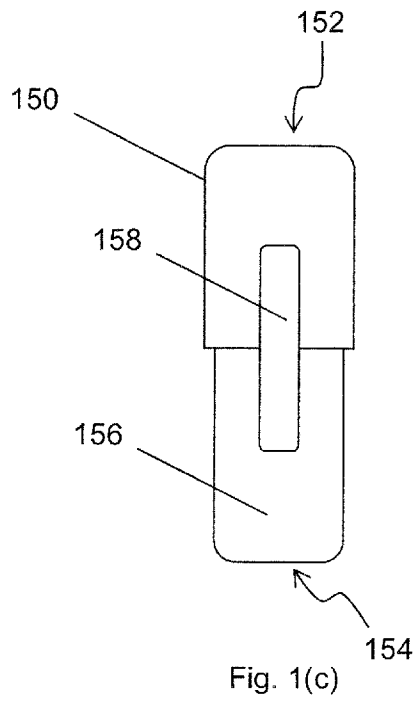

Fig. 1(c)

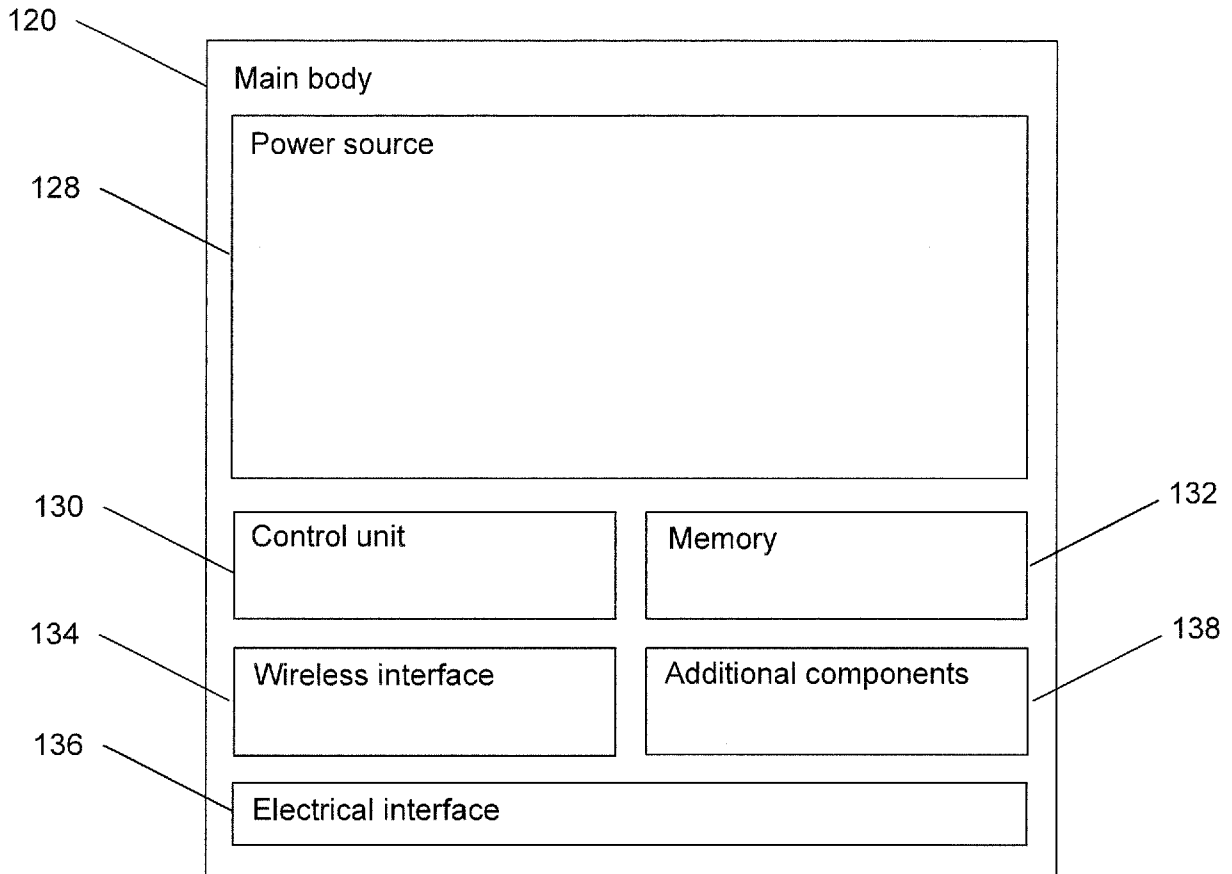

Fig. 2(a)

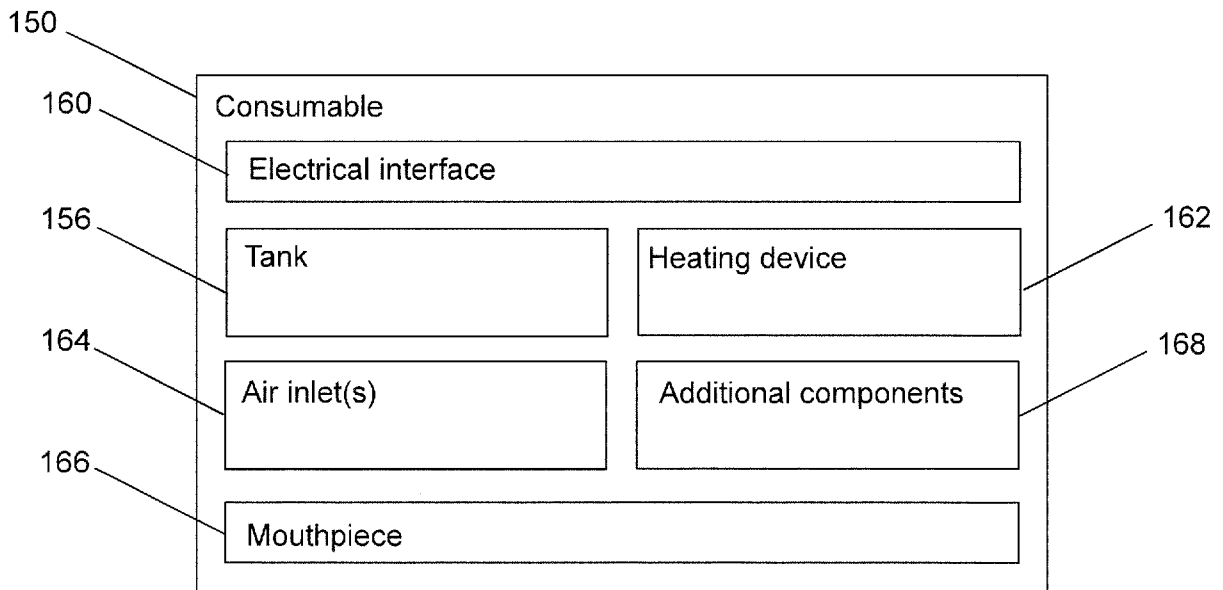
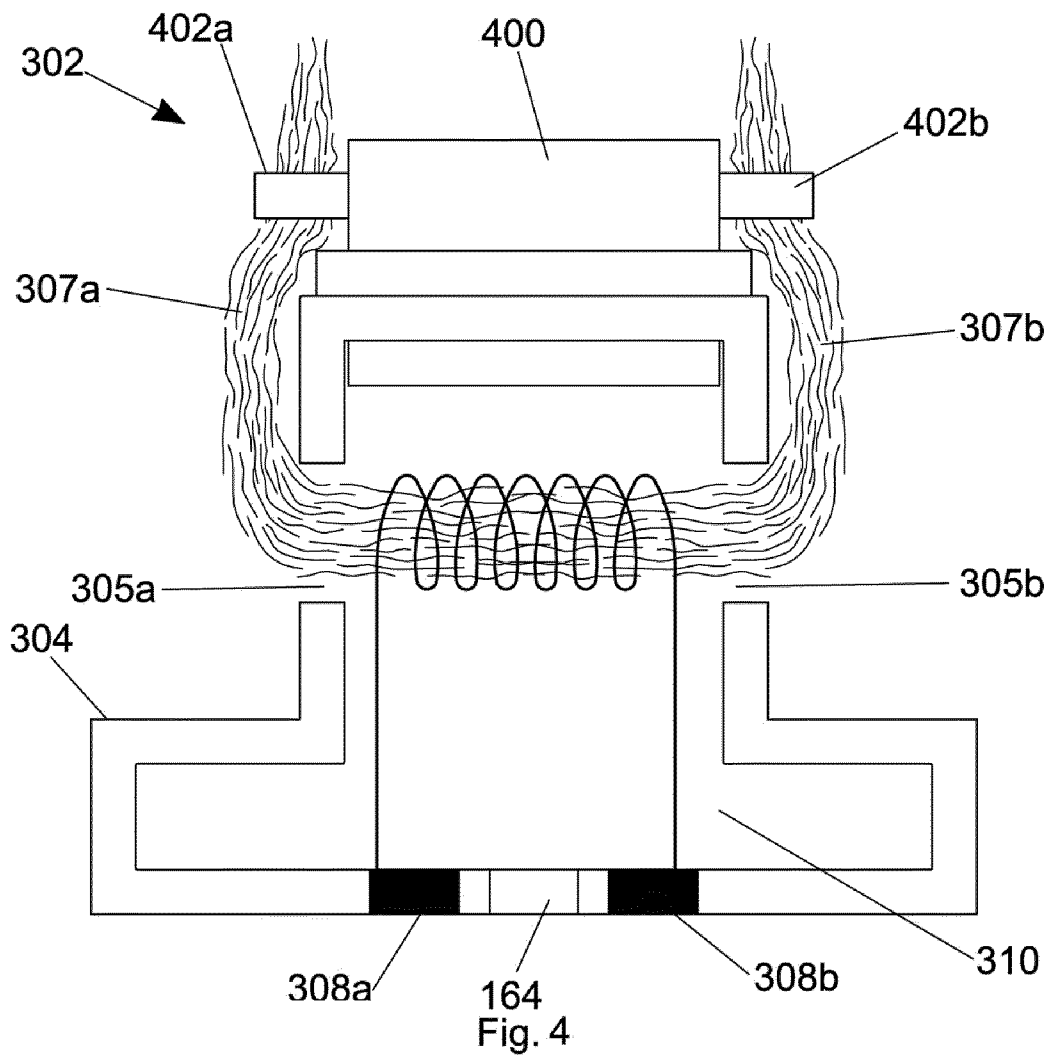
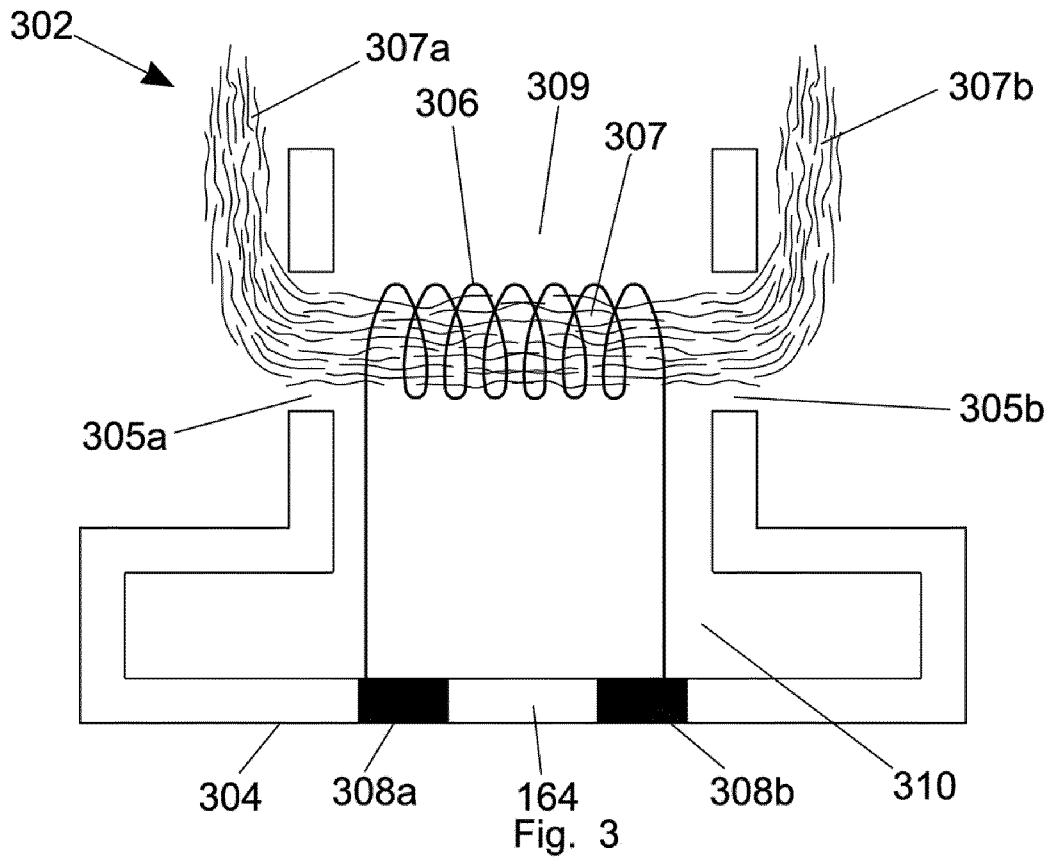

Fig. 2(b)



4/5

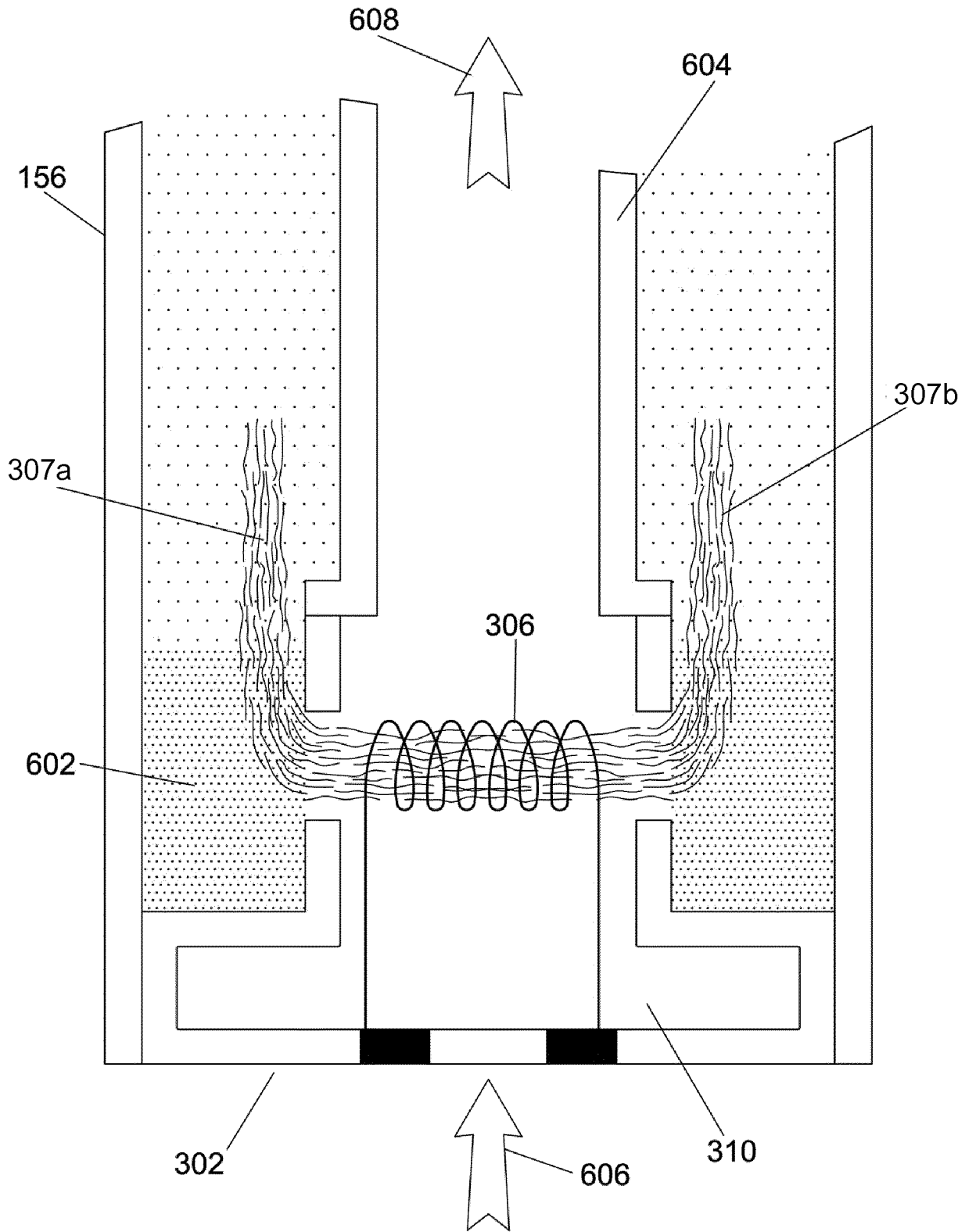

Fig. 5

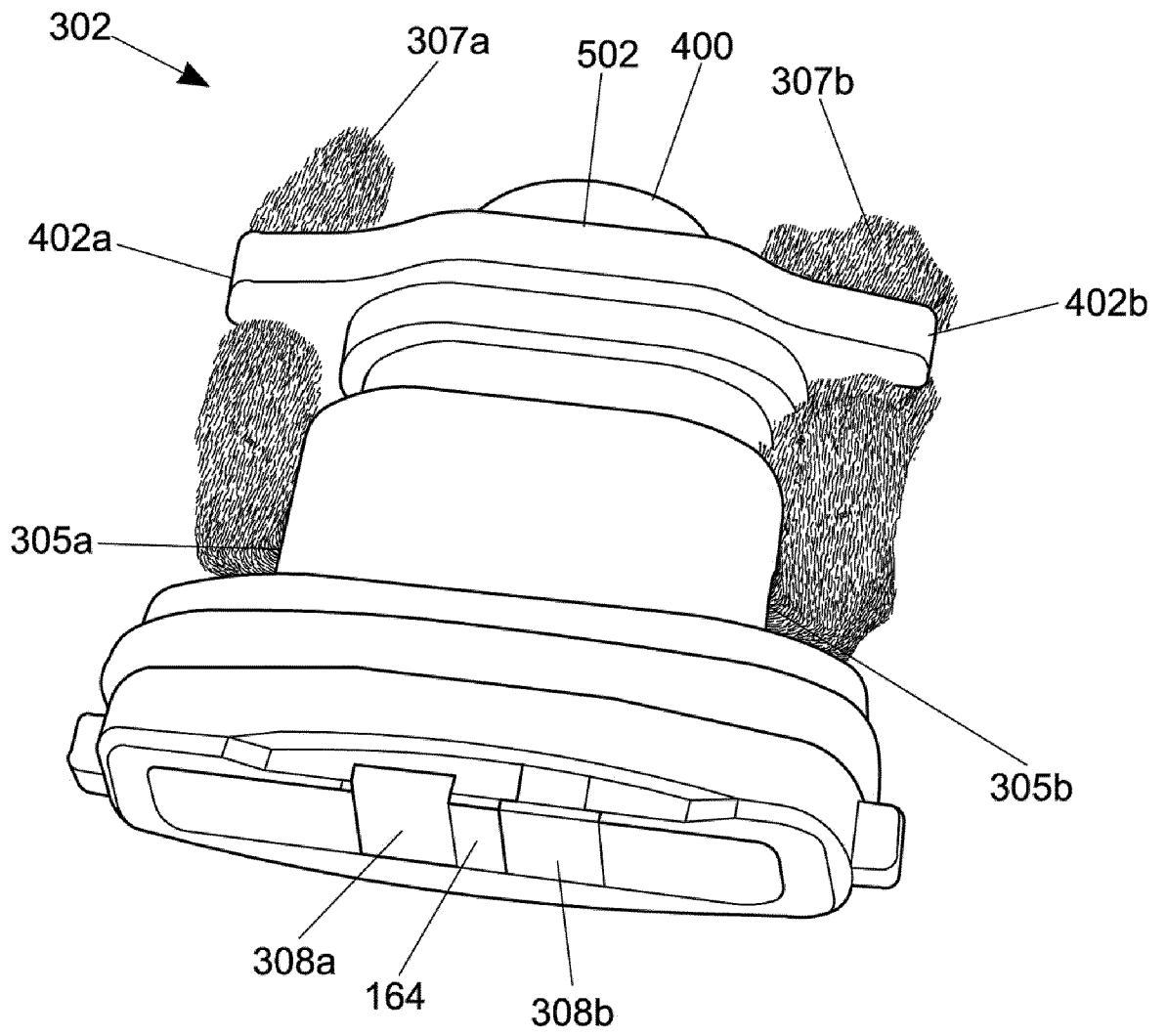

Fig. 6

INTERNATIONAL SEARCH REPORT

International application No
PCT/EP2019/061151

A. CLASSIFICATION OF SUBJECT MATTER
 INV. A24B15/16 A24F47/00
 ADD.
 According to International Patent Classification (IPC) or to both national classification and IPC

B. FIELDS SEARCHED
 Minimum documentation searched (classification system followed by classification symbols)
 A24B A24F
 Documentation searched other than minimum documentation to the extent that such documents are included in the fields searched

Electronic data base consulted during the international search (name of data base and, where practicable, search terms used)
 EPO-Internal, WPI Data

C. DOCUMENTS CONSIDERED TO BE RELEVANT		
Category*	Citation of document, with indication, where appropriate, of the relevant passages	Relevant to claim No.
X	WO 2017/001351 A2 (PHILIP MORRIS PRODUCTS SA [CH]) 5 January 2017 (2017-01-05) page 13, line 32 - page 14, line 6; claims 1,14,15; figures 1, 9a-9c page 2, line 14 - line 32 page 12, line 31 - line 33 -----	1-6,11, 13-15, 17-19
X	WO 2013/060827 A1 (JT INT SA [CH]) 2 May 2013 (2013-05-02) page 8, line 13 - line 17; claims 1-4,10; figures 2-5 page 2, line 25 - line 26 -----	1-12, 16-19

Further documents are listed in the continuation of Box C.

See patent family annex.

* Special categories of cited documents :

"A" document defining the general state of the art which is not considered to be of particular relevance	"T" later document published after the international filing date or priority date and not in conflict with the application but cited to understand the principle or theory underlying the invention
"E" earlier application or patent but published on or after the international filing date	"X" document of particular relevance; the claimed invention cannot be considered novel or cannot be considered to involve an inventive step when the document is taken alone
"L" document which may throw doubts on priority claim(s) or which is cited to establish the publication date of another citation or other special reason (as specified)	"Y" document of particular relevance; the claimed invention cannot be considered to involve an inventive step when the document is combined with one or more other such documents, such combination being obvious to a person skilled in the art
"O" document referring to an oral disclosure, use, exhibition or other means	"&" document member of the same patent family
"P" document published prior to the international filing date but later than the priority date claimed	

Date of the actual completion of the international search 15 July 2019	Date of mailing of the international search report 22/07/2019
---	--

Name and mailing address of the ISA/ European Patent Office, P.B. 5818 Patentlaan 2 NL - 2280 HV Rijswijk Tel. (+31-70) 340-2040, Fax: (+31-70) 340-3016	Authorized officer Villányi Kelemen, K
--	---

INTERNATIONAL SEARCH REPORT

Information on patent family members

International application No

PCT/EP2019/061151

Patent document cited in search report	Publication date	Patent family member(s)	Publication date
WO 2017001351 A2	05-01-2017	CN 107920587 A	17-04-2018
		EP 3313215 A2	02-05-2018
		JP 2018523985 A	30-08-2018
		KR 20180023899 A	07-03-2018
		US 2018295882 A1	18-10-2018
		WO 2017001351 A2	05-01-2017

WO 2013060827 A1	02-05-2013	CN 103929985 A	16-07-2014
		EA 201490609 A1	30-09-2014
		EP 2770856 A1	03-09-2014
		JP 5908099 B2	26-04-2016
		JP 2014530633 A	20-11-2014
		KR 20140097254 A	06-08-2014
		US 2014261483 A1	18-09-2014
		WO 2013060827 A1	02-05-2013
