

No. 665,107.

Patented Jan. 1, 1901.

A. KITSON.
VAPOR BURNING APPARATUS.
(Application filed Apr. 20, 1899.)

(No Model.)

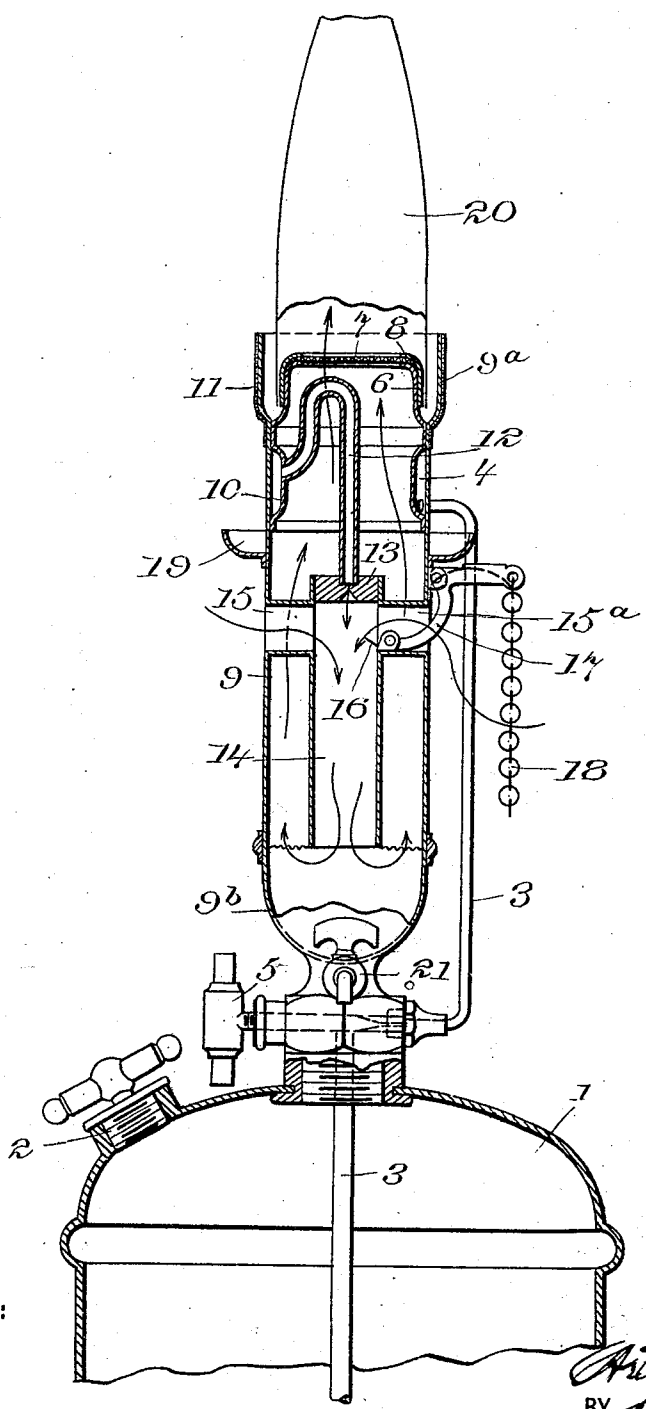

WITNESSES:

[Handwritten signature]

N. N. Humphrey.

INVENTOR

Arthur Kitson

BY

A. Walker Smith

ATTORNEY

UNITED STATES PATENT OFFICE.

ARTHUR KITSON, OF PHILADELPHIA, PENNSYLVANIA, ASSIGNOR TO THE
KITSON HYDROCARBON HEATING AND INCANDESCENT LIGHTING COM-
PANY, OF SAME PLACE AND CHARLESTON, WEST VIRGINIA.

VAPOR-BURNING APPARATUS.

SPECIFICATION forming part of Letters Patent No. 665,107, dated January 1, 1901.

Application filed April 20, 1899. Serial No. 713,707. (No model.)

To all whom it may concern:

Be it known that I, ARTHUR KITSON, a sub-
ject of the Queen of Great Britain, and a resi-
dent of Philadelphia, county of Philadelphia,
5 State of Pennsylvania, have invented certain
new and useful Improvements in Vapor-Burn-
ing Apparatus, of which the following is a
specification.

My invention relates to vapor-burning ap-
paratus; and it consists of an improved form
of burner designed to operate with volatile
hydrocarbon—such as gasolene, naphtha, &c.

The preferred form of apparatus embody-
ing my invention is illustrated in the accom-
panying drawing, in which the figure is a ver-
tical central section of a lamp employing my
burner.

The burner is preferably mounted on a lamp
bowl or reservoir 1, into which burning fluid
and compressed air may be introduced in any
suitable way through the opening 2, closed by
a screw-cap. The supply-pipe 3 runs from
the lower portion of said reservoir up to the
annular vaporizing-chamber 4. The passage
25 of oil through the supply-tube is controlled
by the valve 5.

The burner proper consists of the burner-
thimble 6, the loose gauze 7, stretched across
the opening in said thimble, and the circular
cap 8, which fits over the burner-thimble and
the gauze and retains the gauze in position.
This burner-thimble is located in the upper
end of an upright tube 9, which forms the
main body of the lamp apparatus and up
35 through which tube the combustible mixture
of vapor and air flows to the burner-thimble.
This burner-thimble, at its upper portion at
least, is of less diameter than the upper end
of the tube 9 and is located within the mouth
40 of said tube. This result can be secured by
expanding the lower portion of the burner-
thimble, so that it will fit the body of the tube
tightly, leaving an annular space between the
upper portion of the thimble and the sur-
rounding mouth of the tube 9, or it may be
45 done by expanding the mouth of the tube 9,
as shown at 9^a in the drawing, fitting the thim-
ble into the body of the tube 9, which is of
less diameter, or by both these methods con-
50 jointly, as shown in the drawing.

The annular vaporizing-chamber 4 has one
of its walls, preferably the outer wall, formed
by the tube 9 itself, and the other wall may
be formed by the lower portion 10 of the
burner-thimble, as shown in the drawing. 55
If desired, a covering of non-conducting ma-
terial 11 may be placed around the outside of
the mouth of the upright tube 9, and these
devices will all cooperate to conduct the great-
est possible amount of heat generated in the 60
vicinity of the burner down to the vaporizing-
chamber 4.

The vapor-discharge tube 12 leads from the
vaporizing-chamber 4 and discharges down
through a minute opening in the nozzle 13 65
into the upper end of the mixing-tube 14.
This mixing-tube 14 is of less length and di-
ameter than the upright tube 9 and is located
within the same, preferably concentric there-
to. The lower end of the mixing-tube 14 dis- 70
charges into the lower portion of the upright
tube 9, which lower end is closed and prefer-
ably given a hemispherical form, as shown
at 9^b. Air-conduits 15 15^a pass through the
walls of the upright tube 9 and open into the 75
upper end of the mixing-tube 14. The needle
16, carried by the hinged arm 17, pivoted
to the supporting-tube 9, passes in through
one of these air-conduits 15^a, and when swung
up by pulling on the chain 18 the needle 16 80
will enter the discharge-orifice in the nozzle
13 of the vapor-discharge tube.

19 is an annular alcohol-cup located out-
side of the upright tube 9 and slightly below
the annular vaporizing-chamber 4. 85

20 is an incandescent mantle supported over
the burner in any convenient way (not illus-
trated) and having its lower portion extend-
ing down into the annular space between the
burner-thimble and the mouth of the upright 90
tube 9^a.

21 is a drip-cock opening out from the lower
closed end of the upright tube 9.

22 represents a gauze diaphragm which may
be stretched across the upright tube 9 at the 95
mouth of the mixing-tube 14.

The method of operation of my invention
is as follows: Gasolene being stored in the res-
ervoir 1, together with compressed air, the
pressure of the air will force the gasolene up 100

through the supply-tube 3 through the vaporizing-chamber 4 when the valve 5 is open. In starting the lamp said valve 5 is kept closed and a quantity of alcohol in the cup 19 is ignited. First, the heat of the alcohol-flame heats the metallic parts of the tube 9 to a point sufficient to vaporize the gasolene when it is introduced into the vaporizing-chamber 4. The valve 5 is then opened, gasolene flows into the chamber 4 and is therein vaporized. The vapor passes out through the vapor-discharge tube 12 and issues in the shape of a downward jet through the orifice 13. This jet draws in air through the air-conduits 15 15^a, and the mixture passes down the mixing-tube 14 and is discharged into the lower closed end 9^b of the upright tube. It is then forced up through said tube 9 and issues from the burner, where it is ignited and burns under the mantle 20, causing the same to give out light by incandescence. The heat of the burner and of the lower portion of the mantle 20 is transmitted by the thimble 6 and tube 9 back to the vaporizing-chamber 4 and keeps the same hot enough to continue the vaporization of gasolene, the action of the lamp thus becoming self-supporting.

If the discharge-orifice 13 becomes clogged up, the needle 16 can be swung up by pulling the chain 18. The needle will pass through the discharge-opening and free the same from any carbon or other material located therein. On withdrawing the needle to the position shown in the drawing the lamp will be left free to operate as before.

The advantages of the invention consist in the compact structure produced, everything being contained within the single upright tube 9 and hidden from view. In spite of this compactness and simplicity a thorough vaporization of the gasolene is insured by the fact that the vaporizing-chamber is near the burner and formed by the extended metal portions of said burner itself. The vapor is thoroughly mixed with the air even within the small space afforded by the apparatus by reason of the fact that the mixture is compelled to travel back and forth and reverse its direction of flow; also, the vapor-discharge pipe 12 and the inner walls of the vaporizing-chamber 4 are bathed in this heated mixture and so protected from all cooling action, except that of the atmosphere on the outer wall of the chamber.

It is evident that various changes could be made in the details of construction illustrated without departing from the spirit and scope of my invention so long as the relative arrangement of parts shown in the drawing or the general principle of operation described in the specification is preserved. Other shapes might be given to the burner-thimble, the upright tube, vapor-discharge pipe, alcohol-cup, &c., and certain of the features of my invention might be employed without the coöperation of others therein described; but all these

changes I consider matters of form and not of substance and still within the scope of my invention.

The form, construction, and connections of, for example, the upright tube, the mixing-tube, vapor-delivery tube, &c., herein shown and described, are not specifically claimed, for the reason that certain of these parts combined in various ways constitute the subject-matter of other applications now pending.

Having therefore described my invention, what I claim as new, and desire to protect by Letters Patent, is—

1. In a vapor-burning apparatus the combination of the upright tube, having its upper end open, up through which the combustible mixture flows, and the burner-thimble having imperforate sides of less diameter located within said upper end of the tube, a portion only of the imperforate body of the thimble being expanded and fitting tightly into the body of the tube.

2. In a vapor-burning apparatus the combination of the upright tube with its mouth expanded, and the burner-thimble having imperforate sides of less diameter than said expanded mouth located within the same, the lower portion of said thimble fitting tightly into the body of the tube at a point below the mouth portion.

3. In a vapor-burning apparatus, the combination of the upright tube with its mouth expanded and the burner-thimble having its diameter varied throughout its length and seated in said expanded mouth, one or more portions of the body of the thimble fitting tightly into the body of the tube.

4. In a vaporizing apparatus the combination of the upright tube having its lower end closed, the burner-thimble mounted within the tube at its upper end, the annular vaporizing-chamber near the burner having one of its walls formed by the upright tube, the mixing-tube of less length and diameter than the upright tube and located within the same, the vapor-discharge tube leading from the vaporizing-chamber and discharging down into the mixing-tube, and the air-conduits through the walls of the upright tube opening into the upper end of the mixing-tube.

5. In a vapor-burning apparatus the combination of the upright tube having its upper end open to form a mouth up through which the combustible mixture flows, the burner-thimble of less diameter than the mouth of the upright tube and located within said mouth but fitting tightly the bore of the tube, and the annular vaporizing-chamber, one wall of which is formed by said upright tube, the other wall of said vaporizing-chamber being formed by the lower portion of the burner-thimble, together with the mixing-tube of less length and diameter than the upright tube and located within the same, the vapor-discharge tube leading from the vapo-

5 rizing-chamber and discharging down into the mixing-tube, and the air-conduits through the walls of the upright tube opening into the upper end of the mixing-tube, the lower end of the main upright tube being closed.

6. In a vaporizing apparatus the combination of the upright tube having its lower end closed, the burner-thimble mounted in its upper end, the annular vaporizing-chamber near the burner, having one of its walls formed by the upright tube, the mixing-tube of less length and diameter than the upright tube and located within the same, the vapor-discharge tube leading from the vaporizing-chamber and discharging down into the mixing-tube, and the air-conduits through the walls of the upright tube opening into the upper end of the mixing-tube, together with the needle-hole cleaner pivoted to the upright tube and extending in through one of the air-conduits.

7. In a vapor-burning apparatus the combination of the upright tube having its upper end open to form a mouth up through which the combustible mixture flows, the burner-thimble of less diameter than the mouth of the upright tube and located within said mouth but fitting tightly to the body of the tube, and the annular vaporizing-chamber, one wall of which is formed by said upright tube, together with the incandescent mantle supported over said burner and extending down into the annular space between the burner-thimble and the mouth of the upright tube.

Signed by me at Philadelphia, Pennsylvania, this 28th day of March, 1899.

ARTHUR KITSON.

Witnesses:

THOS. K. OBER, Jr.,
LOUIS R. BAKER.