

(No Model.)

R. HERMAN.
DISTRIBUTING BOARD FOR ELECTRIC CIRCUITS.

No. 522,370.

Patented July 3, 1894.

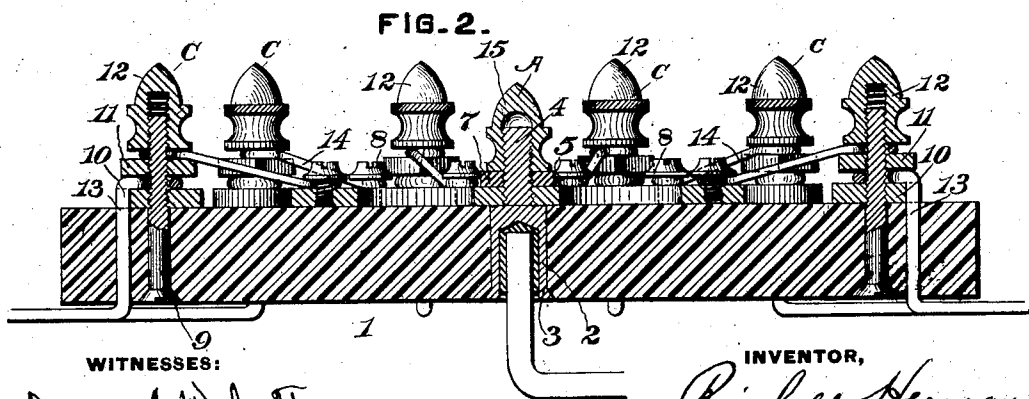
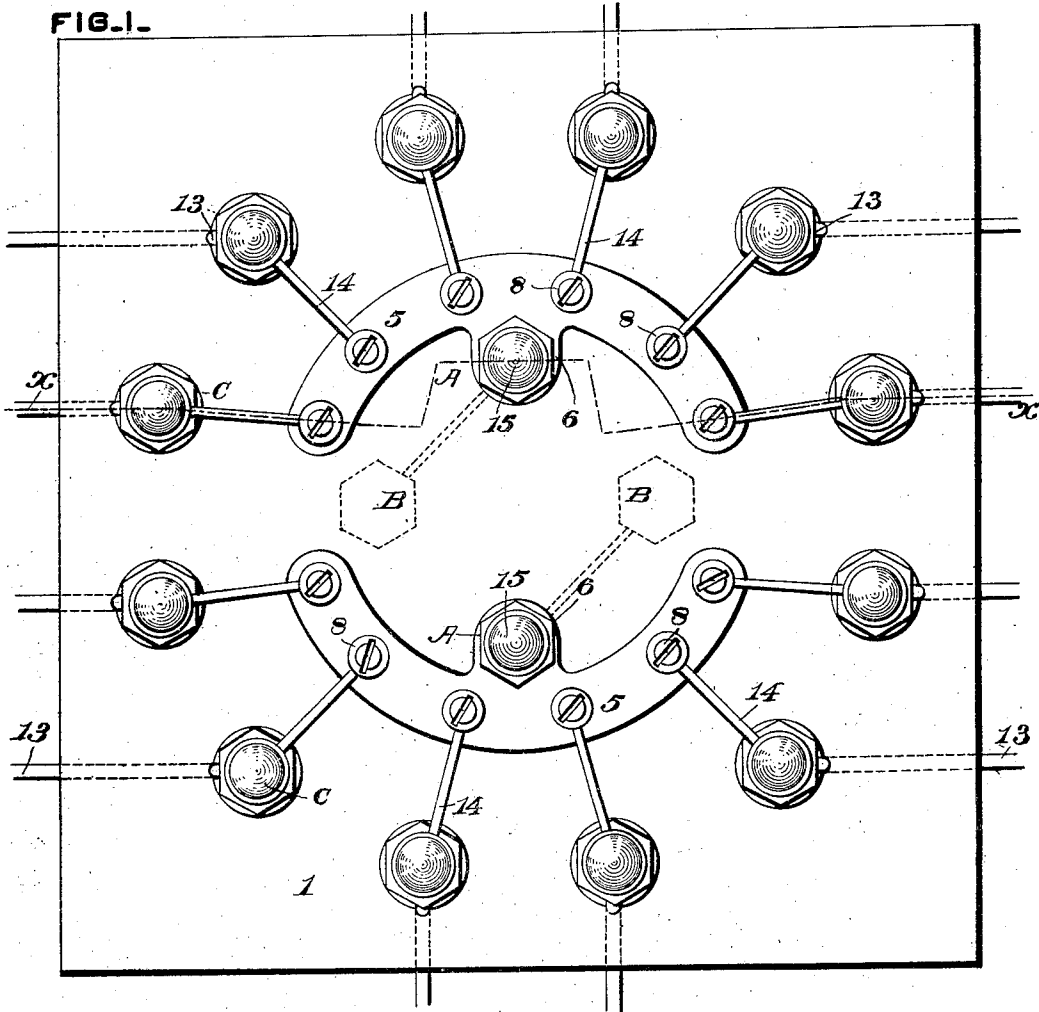

WITNESSES:
Darius B. Wolcott
C. E. Hunt.

INVENTOR,
Reinhold Herman
by George H. Christy
Atty.

UNITED STATES PATENT OFFICE.

REINHOLD HERMAN, OF CRAFTON, PENNSYLVANIA.

DISTRIBUTING-BOARD FOR ELECTRIC CIRCUITS.

SPECIFICATION forming part of Letters Patent No. 522,370, dated July 3, 1894

Application filed December 14, 1893. Serial No. 493,677. (No model.)

To all whom it may concern:

Be it known that I, REINHOLD HERMAN, a citizen of the United States, residing at Crafton, in the county of Allegheny and State of Pennsylvania, have invented or discovered certain new and useful Improvements in Distributing-Boards for Electric Circuits, of which improvements the following is a specification.

The invention described herein relates to certain improvements in distributing boards for electric circuits, and has for its object a construction wherein the main and distributing wires may be readily attached to their terminals and the distributing circuits in any desired number connected to the terminals of the main circuits by fuse strips.

In general terms, the invention consists in the construction and combination, substantially as hereinafter more fully described and particularly claimed.

In the accompanying drawings forming a part of this specification, Figure 1 is a top plan view of my improved distributing board, and Fig. 2 is a section of the same, the plane of section being indicated by the line *x, x*, Fig. 1.

In the practice of my invention, the base or support 1 of the terminals is formed of slate, marble or any other suitable non-conducting material.

The terminals A for the main circuit consist of a metal socket 2 preferably formed of brass, having a flange or shoulder 3 at one end and a threaded stem 4 at its opposite end, as shown in Fig. 2. These sockets having the ends of the main wires secured therein preferably by solder, are placed in suitable openings in the base or support 1, the flanges or shoulders 3 entering countersinks around the openings in the base, thereby preventing the sockets passing through the openings.

When several circuits are to be connected to the main circuit, curved metal plates 5 provided with perforated lips 6 are placed on the upper side of the base or support, so that the threaded stems 4 will pass through the holes in the lips. The plates 5 are held in position on the base by nuts 7 screwing onto the threaded stems, as shown in Fig. 2. The plates 5 are provided with a series of threaded holes for the reception of the screws 8 corresponding to the number of circuits to be taken off.

The terminals C for the distributing wires may be constructed in the same manner as the terminals A, or may be made with solid body portions 9, having flanges or shoulders at one end, the opposite ends being threaded. When using this form of terminal the ends of the wires 13 for the distributing circuits are passed through holes formed through the base or support adjacent to the terminals 9, so that they will engage notches formed in the edges of the holding nuts 10, as shown in Fig. 2. The wires thus engaging the nuts 10 not only serve to lock the nuts, but are also held by said notches, while the ends are being bent around the threaded stems immediately above the nuts. The nuts 11 are then screwed down upon the bent ends of the wires, thereby clamping such ends tightly in position and forming good electrical contact therewith. The distributing terminals are connected with the plates 5 by means of the fusible wires 14, whose ends are bent around the screws 8, below their heads and around the terminals 9 just above the nuts 11, and are firmly clamped on the bolts by the cap nuts 12, which also serve to lock the nuts 11 on the terminals.

When it is desired to continue the main circuit to another distributing board, terminals B, consisting of sockets 2 having the shoulders 3 and threaded stems 4, nuts 7 and cap nuts 15, are arranged on the base or support as indicated by dotted lines in Fig. 1. The terminals A and B are connected by fusible wires, which are wound around the threaded stems above the nuts 7, and are held in position by the cap nuts 15. The ends of the wires forming the continuation of the main circuit are soldered in the sockets of the terminals B, as hereinbefore described.

I claim herein as my invention—

1. In a distributing board for electric circuits the combination of an insulating base or support, terminals provided with sockets for the reception of the ends of the main circuits, and with a threaded stem, metal provided with openings for the threaded stems and clamped to the base or support by nuts screwing onto the threaded stems, a series of distributing terminals passing through the base or support, nuts screwing onto said terminals and provided with notches for the reception of the distributing wires, nuts for

clamping said wires onto the terminals, fusible wires extending from the plates to the terminals and nuts for clamping such fusible wires on the terminals, substantially as set forth.

2. A terminal for a distributing board having in combination a socket portion provided with a shoulder or flange, a threaded stem, a holding nut and a lock nut fitting on the threaded stem, substantially as set forth.

3. The combination of a board or support, a terminal having a body portion provided at one end with a shoulder or flange and with a threaded portion at its opposite end, a notched nut for securing the terminal in position on the board, a clamping nut and a second clamp-

ing or locking nut screwing onto the threaded portion, substantially as set forth.

4. A terminal for a distributing board having in combination a body portion provided at one end with a flange or shoulder and threaded at its opposite end, in combination with a nut notched for the reception of a wire to be electrically connected to the terminal, whereby the nut may be locked on the body portion of the terminal, substantially as set forth.

In testimony whereof I have hereunto set my hand.

REINHOLD HERMAN.

Witnesses:

DARWIN S. WOLCOTT,
F. E. GAITHER.