

(19) World Intellectual Property Organization
International Bureau



(43) International Publication Date
2 June 2005 (02.06.2005)

PCT

(10) International Publication Number
WO 2005/050180 A1

(51) International Patent Classification⁷: G01N 21/47, 21/17, A61B 5/00

(21) International Application Number: PCT/US2004/038599

(22) International Filing Date: 17 November 2004 (17.11.2004)

(25) Filing Language: English

(26) Publication Language: English

(30) Priority Data: 10/714,734 17 November 2003 (17.11.2003) US

(71) Applicant (for all designated States except US): GENERAL ELECTRIC COMPANY [US/US]; 1 River Road, Schenectady, NY 12345 (US).

(72) Inventors; and

(75) Inventors/Applicants (for US only): JANSEN, Floribertus, Heukensfeldt [NL/US]; 7 Stonegate Road, Ballston Lake, NY 12019 (US). LORRAINE, Peter, William [CA/US]; 876 Heather Lane, Niskayuna, NY 12309 (US).

LOMNES, Stephen, Johnson [US/US]; 44 Willett Street, Apt. 5R, Albany, NY 12210 (US). FOMITCHOV, Pavel Alexeyevich [RU/US]; 1100 Union Street, Apt. 5, Schenectady, NY 12308 (US).

(74) Agents: HAYDEN, Scott et al.; Patent Counsel, General Electric Company, 3135 Easton Turnpike (W3C), Fairfield, CT 06828 (US).

(81) Designated States (unless otherwise indicated, for every kind of national protection available): AE, AG, AL, AM, AT, AU, AZ, BA, BB, BG, BR, BW, BY, BZ, CA, CH, CN, CO, CR, CU, CZ, DE, DK, DM, DZ, EC, EE, EG, ES, FI, GB, GD, GE, GH, GM, HR, HU, ID, IL, IN, IS, JP, KE, KG, KP, KR, KZ, LC, LK, LR, LS, LT, LU, LV, MA, MD, MG, MK, MN, MW, MX, MZ, NA, NI, NO, NZ, OM, PG, PH, PL, PT, RO, RU, SC, SD, SE, SG, SK, SL, SY, TJ, TM, TN, TR, TT, TZ, UA, UG, US, UZ, VC, VN, YU, ZA, ZM, ZW.

(84) Designated States (unless otherwise indicated, for every kind of regional protection available): ARIPO (BW, GH, GM, KE, LS, MW, MZ, NA, SD, SL, SZ, TZ, UG, ZM, ZW), Eurasian (AM, AZ, BY, KG, KZ, MD, RU, TJ, TM), European (AT, BE, BG, CH, CY, CZ, DE, DK, EE, ES, FI, FR, GB, GR, HU, IE, IS, IT, LU, MC, NL, PL, PT, RO, SE,

[Continued on next page]

(54) Title: METHOD AND SYSTEM FOR ULTRASONIC TAGGING OF FLUORESCENCE

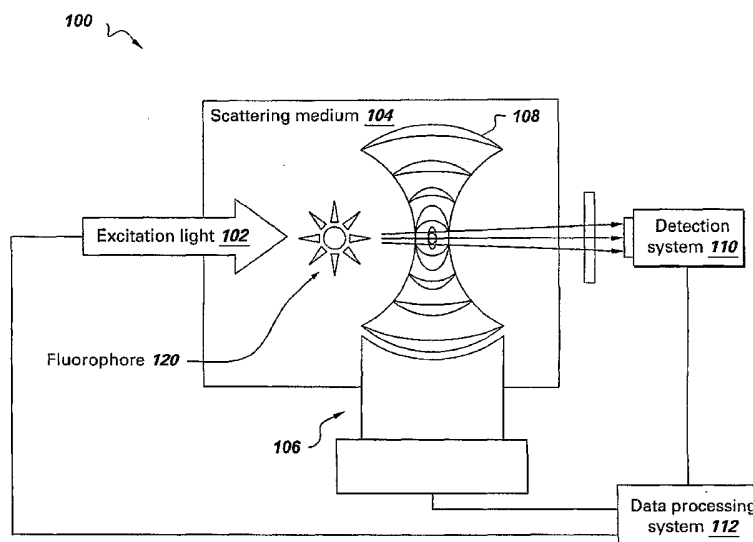

(57) Abstract: A method and system for localization of fluorescence (120) in a scattering medium (104) such as a biological tissue are provided. In comparison to other optical imaging techniques, this disclosure provides for improved spatial resolution, decreased computational time for reconstructions, and allows anatomical and functional imaging simultaneously. The method including the steps of illuminating the scattering medium with an excitation light (102) to excite the fluorescence; modulating a portion of the emitted light from the fluorescence within the scattering medium using an ultrasonically induced variation (108) of material properties of the scattering medium (104) such as the refractive index; detecting the modulated optional signal at a surface of the scattering medium; and reconstructing a spatial distribution of the fluorescence in the scattering medium from the detected signal.

WO 2005/050180 A1



SI, SK, TR), OAPI (BF, BJ, CF, CG, CI, CM, GA, GN, GQ, GW, ML, MR, NE, SN, TD, TG).

Declarations under Rule 4.17:

- *as to applicant's entitlement to apply for and be granted a patent (Rule 4.17(ii)) for the following designations AE, AG, AL, AM, AT, AU, AZ, BA, BB, BG, BR, BW, BY, BZ, CA, CH, CN, CO, CR, CU, CZ, DE, DK, DM, DZ, EC, EE, EG, ES, FI, GB, GD, GE, GH, GM, HR, HU, ID, IL, IN, IS, JP, KE, KG, KP, KR, KZ, LC, LK, LR, LS, LT, LU, LV, MA, MD, MG, MK, MN, MW, MX, MZ, NA, NI, NO, NZ, OM, PG, PH, PL, PT, RO, RU, SC, SD, SE, SG, SK, SL, SY, TJ, TM, TN, TR, TT, TZ, UA, UG, UZ, VC, VN, YU, ZA, ZM, ZW, ARIPO patent (BW, GH, GM, KE, LS, MW, MZ, NA, SD, SL, SZ, TZ, UG, ZM, ZW), Eurasian patent (AM, AZ, BY, KG, KZ, MD, RU, TJ, TM), European patent (AT, BE, BG, CH, CY, CZ, DE, DK, EE, ES, FI, FR, GB, GR, HU, IE, IS, IT, LU, MC, NL, PL, PT, RO, SE, SI, SK, TR), OAPI patent (BF, BJ, CF, CG, CI, CM, GA, GN, GQ, GW, ML, MR, NE, SN, TD, TG)*
- *as to the applicant's entitlement to claim the priority of the earlier application (Rule 4.17(iii)) for the following designations AE, AG, AL, AM, AT, AU, AZ, BA, BB, BG, BR, BW, BY, BZ, CA, CH, CN, CO, CR, CU, CZ, DE, DK, DM, DZ, EC, EE, EG, ES, FI, GB, GD, GE, GH, GM, HR, HU, ID,*

IL, IN, IS, JP, KE, KG, KP, KR, KZ, LC, LK, LR, LS, LT, LU, LV, MA, MD, MG, MK, MN, MW, MX, MZ, NA, NI, NO, NZ, OM, PG, PH, PL, PT, RO, RU, SC, SD, SE, SG, SK, SL, SY, TJ, TM, TN, TR, TT, TZ, UA, UG, UZ, VC, VN, YU, ZA, ZM, ZW, ARIPO patent (BW, GH, GM, KE, LS, MW, MZ, NA, SD, SL, SZ, TZ, UG, ZM, ZW), Eurasian patent (AM, AZ, BY, KG, KZ, MD, RU, TJ, TM), European patent (AT, BE, BG, CH, CY, CZ, DE, DK, EE, ES, FI, FR, GB, GR, HU, IE, IS, IT, LU, MC, NL, PL, PT, RO, SE, SI, SK, TR), OAPI patent (BF, BJ, CF, CG, CI, CM, GA, GN, GQ, GW, ML, MR, NE, SN, TD, TG)

Published:

- *with international search report*

For two-letter codes and other abbreviations, refer to the "Guidance Notes on Codes and Abbreviations" appearing at the beginning of each regular issue of the PCT Gazette.

METHOD AND SYSTEM FOR ULTRASONIC TAGGING OF FLUORESCENCE

BACKGROUND OF THE INVENTION

This disclosure relates generally to medical imaging systems, and more particularly, to methods and systems for localization of fluorescent dyes in a scattering medium, e.g., biological tissue.

Millions of women participate in x-ray mammography each year. The specificity of this exam for radiologically dense breasts is not optimal. Suspicious lesions are subject to follow-up with other modalities such as ultrasound imaging, and ultimately are likely to be examined by biopsy. The physical discomfort and psychological impact to the women who obtain false-positive results from this screening procedure is immeasurable. The low sensitivity of the procedure gives rise to a high number of false negative results. This, in turn, leads to later stage detection of the disease and poorer patient prognostics. The rate of women having x-ray mammography screening is increasing annually, which leads to an overall earlier detection of suspect lesions. However, the increased frequency of mammography procedures, combined with the risks associated with the increased exposure to ionizing radiation brings into focus the clinical need for an alternate screening procedure that provides increased diagnostic sensitivity and specificity in radiologically dense breast tissue, that uses nonionizing radiation. One technology that shows promise for impacting this clinical challenge is Optical Imaging.

Optical imaging has the potential of developing into a highly sensitive modality that makes use of harmless levels of near-infrared light (NIR). Endogenous screening procedures have been proposed that use multiple wavelengths of NIR light to measure the relative levels of oxy- and deoxy-hemoglobin. This ratio has been proposed as a functional indicator for malignant tissue. Others have been working to create targeted fluorescent optical contrast agents that would selectively bind to biomarkers that are indicators of the presence of malignant tissue. The addition of targeted fluorescent contrast agents could potentially improve the diagnostic specificity of this technology.

The list of variants of optical imaging technologies that are being developed for this particular clinical problem comprises continuous wave imaging (CW), time domain photon migration imaging (TDPM), frequency domain photon migration imaging (FDPM), thermo-acoustic computed tomography (TCT), and imaging with ultrasonically tagged light (UTL).

Continuous wave optical imaging - Continuous wave (CW) techniques involve illuminating a subject using one or more wavelengths of light and detecting the returning light at a separate location. The illumination is time-invariant. The technique boasts a low cost and complexity method for interrogating tissue for absorption, spectroscopic investigation, and for fluorescence imaging. However, the information contained within the signal is largely dominated by a signal from the most shallow portions of the tissue under investigation. This limits the usefulness of this technique for deep tissue interrogation.

Time domain photon migration (TDPM) - The depth limitation cited for CW techniques can be mitigated by using a short pulse of input light at one location and looking at the temporal point spread function, at a different location. This allows one to distinguish signal attributed to long times of flight from the more dominant shallow signal. The technique uses ultrashort pulsed lasers and photon detection schemes with very high temporal resolution. The instrumentation is typically more expensive as a consequence of increased hardware complexity. Because there is a physical mechanism for discriminating portions of the signal by time-of-flight, it has been possible to demonstrate reconstruction based on approximations of the Radiative Transport Equation via linearizations and iterative optimization methods. Tomography is limited due to the severely ill-posed nature of the imaging system. That is to say that even a large change of the optical properties of an interior region of interest deep in the tissue, results in only a small change in detected optical signal. It is for this reason that generating reliable maps of the optical properties has proven difficult.

Frequency domain photon migration (FDPM) - This techniques increases optical imaging sensitivity by illuminating the subject using sinusoidally time-varying

excitation light. Information is recovered using heterodyne or homodyne techniques to measure the amplitude and phase of the output signal. These signal characteristics can provide information about the absorption and the scatter of the tissue. The technique has been used in endogenous and exogenous, single and multi-wavelength modes and can provide information for tomographic reconstruction. Like the TDPM technique, FDPM uses the Radiative Transport Equation for reconstruction.

Thermoacoustic computed tomography - A significantly less ill-posed technique that combines optical absorption imaging and acoustic imaging is thermoacoustic computed tomography. A NIR optical pulse is sent into the subject. The optical energy is absorbed preferentially by absorbing features (presumably, abnormalities in the tissue). The tissue which is thus heated generates a thermoacoustic shock wave. This acoustic signal is collected on the boundary of the subject and reconstructed to generate maps of optical absorption. This technique has the advantage of using acoustic techniques for detection. It provides an advantage because acoustic energy is scattered more weakly than optical energy, and the speed of sound in tissue is low enough to allow accurate triangulation of the origin of the shock wave. The modality is used to generate maps of relative optical absorption which are thought to correspond to regions of increased blood supply in the region of a malignant tumor as a result of angiogenesis.

Ultrasound tagging of light (UTL) - Researchers have demonstrated that it is possible to make the optical imaging problem less ill-posed by yet another combination of ultrasound and optical imaging. The strategy described here is to add a frequency "tag" to optical signals that have traveled through a known location in the tissue insonified with ultrasound. This allows an instrument to discriminate light that traveled through a location from light that has not. This phenomenon of acoustic tagging of coherent light in a scattering medium was first described by Marks, Tomlinson and Brooksby in "A comprehensive approach to breast cancer detection using light; photon localization by ultrasound modulation and tissue characterization by spectral discrimination" Proceedings of SPIE, Vol. 1888, pp. 500-510, 1993. Since that time a number of researchers have advanced the field to the point of being able to generate tomographic images that map relative absorption of the tissue. Regions of

higher vasculature can be visualized using UTL. The diagnostic hypothesis hinges on the correlation of increased regional blood density to angiogenesis.

BREIF DESCRIPTION OF THE INVENTION

A method and system for localization of fluorescent dyes in a scattering medium such as a biological tissue are provided. In comparison to other optical imaging techniques, this disclosure provides for improved spatial resolution, decreased computational time for reconstruction, and allows simultaneous anatomical and functional imaging using light-emitting agents.

According to an aspect of the disclosure, a method for localization of fluorescence in a scattering medium is provided. The method includes the steps of illuminating the scattering medium with an excitation light to excite the fluorescence; modulating a portion of the emitted light from the fluorescence within the scattering medium using an ultrasonic pulse; detecting the modulated optical signal at the surface of the scattering medium; and reconstructing a spatial distribution of fluorescence in the scattering medium from the detected signal.

In another aspect of the present disclosure, a system for localization of fluorescence in a scattering medium comprises an excitation light source for illuminating the scattering medium; a fluorescent dye within a preselected region of the scattering medium for absorbing and emitting light in the NIR (near infrared) region of the light spectrum; an ultrasonic scanning system for generating ultrasonic pulses, wherein the ultrasonic pulses modulate the emitted light from the fluorescent dye; an optical detection system for detecting the modulated light; and a data processing system acquiring the detected optical signal and generating a spatial distribution of the fluorescence in the scattering medium based on the detected optical signals.

BRIEF DESCRIPTION OF THE DRAWINGS

The above and other aspects, features, and advantages of the present invention will become more apparent in light of the following detailed description when taken in conjunction with the accompanying drawings in which:

FIG. 1 is an exemplary system for illustrating the principle of acoustic modulation of fluorescent light;

FIG. 2 is a schematic diagram of an exemplary imaging system;

FIG. 3 is a flowchart illustrating a data processing algorithm for localizing an object of interest in a scattering medium;

FIG. 4 is a diagram illustrating an application of multiple excitation sources and waveforms read by multiple detectors;

FIG. 5 is a partial view for illustrating an embodiment for reading from multiple detector points;

FIG. 6 is a partial view for illustrating another embodiment for reading from multiple detectors;

FIG. 7 is a partial view for illustrating an application of multiple ultrasound generators;

FIG. 8 illustrates an embodiment of an imaging system as a hand-held device; and

FIG. 9 is a graph illustrating a typical signal acquired according to an embodiment of the present disclosure.

DETAILED DESCRIPTION OF THE INVENTION

Preferred embodiments of the present invention will be described hereinbelow with reference to the accompanying drawings. In the following description, well-known functions or constructions are not described in detail to avoid obscuring the invention in unnecessary detail.

A system and method for the localization of fluorescent dyes in a scattering medium are provided. In various embodiments of the present invention, systems and methods will be employed for localizing an object of interest, e.g., a lesion labeled with a fluorescent dye, in a scattering medium, e.g., biological tissue.

Referring to FIG. 1, the system 100 generally includes an optical excitation source 102 for irradiating or illuminating a scattering medium 104, including an object of interest 120, with radiant energy, e.g., light. The light excites a fluorophore contrast agent present in the object of interest 120. The system 100 further includes an ultrasonic generation system 106 for generating ultrasound pulses into the scattering medium 104 inducing an acoustic lens 108. The light emitted from the object of interest 120 is deflected by the acoustic lens 108. A detection system 110 for detecting the radiant energy, e.g., light, deflected by the acoustic lens 108 is also provided. A data processing system 112 collects data from the detection system 110 to construct an image of the scattering medium 104 and controls the overall operations of the excitation light source 102, ultrasonic generation system 106 and detection system 110, which will be described in detailed below.

Alternatively, the ultrasonic generation system 106 will induce the acoustic lens 108 to modulate the excitation light before it reaches the object of interest 120. The modulated light will then excite the fluorophore contrast agent in the object of interest which will emit light to be detected by the detection system 110.

A system and method for localizing an object of interest in a scattering medium will now be described in reference to FIGS. 2 and 3, where FIG. 2 is an exemplary imaging system and FIG. 3 is a flowchart illustrating a data processing algorithm for localizing the object of interest in the scattering medium

Prior to the imaging procedure, a fluorescent optical contrast agent is introduced into a scattering medium 104, e.g., biological tissue. The fluorescent contrast agent may preferentially bind to an object of interest 120, e.g., diseased tissue, and thus may have disease or functional specificity. The fluorescent contrast agent may be one or more or a derivative of the following: Indocyanine green (ICG); a member of the Cy

family of dyes; the IR-78 dye, or any other fluorophore that emits in the NIR region. The fluorescent contrast agent will absorb and emit light in the “transparency window” of biological tissue, which is between 700-900 nm where absorption of light in tissue is minimized. In other applications, it may be useful to operate anywhere in the range from 400-2000nm for use with light emitting agents that operate in these wavelengths.

An optical excitation source 102 with a spectral output tuned to a maximal absorption wavelength of the fluorescent dye is used to excite the fluorescence. The excitation light source will include a light source 202 such as a laser; laser diode; light emitting diode (LED) or a lamp, e.g., halogen, incandescent, arc lamp, high intensity discharge etc.. Excitation irradiation from the optical source is delivered to a surface of the biological tissue 104 using free-space optical system including a beam expander 204 to create a large illumination area that covers most of tissue surface and an optical spectral filter 206 for band pass, notch, or low pass filtering of the light to minimized the amount of excitation light in the expected emission band. Alternatively, multiple sources deliver the light via optical fiber or fiber optic bundles to form an array of localized illumination spots that may be illuminated simultaneously or in a sequence. The optical source can be operated in continuous wave (CW), intensity modulated, or pulsed mode. The frequency of intensity modulation and pulse repetition rate may be equal or fractional with respect to an ultrasonic frequency of the ultrasonic generation system 106.

When excitation photons reach the fluorescent dye in the object of interest 120, e.g., a lesion, localized in a volume of biological tissue, the fluorescence will re-emit optical radiation at a longer wavelength and acts as an omnidirectional optical source.

A focused ultrasonic beam is then formed using the ultrasonic generation system 106. The ultrasonic generation system may include (i) a single focused piezoelectric ultrasonic transducer (PZT) 210 coupled to an arbitrary function generator 214 and a high power RF amplifier 212; (ii) an ultrasonic scanning phased array, or (iii) a laser photoacoustic generator. The generated ultrasonic beam is transmitted into and scanned throughout the volume of the tissue. The ultrasonic generation can be

performed in CW mode, or in pulsed mode using single frequency or frequency-swept tonebursts, or a short single broadband pulse. The ultrasonic beam can be configured as a single ultrasonic focal spot; an array of focal spots situated along a single line; a line focused beam oriented along optical source-to-receiver axis; superposition of two or more ultrasonic beams to form an acoustic interference pattern at the same frequency; or superposition of two or more ultrasonic beams to form an acoustic interference pattern at different frequencies.

The generated ultrasonic wave changes refractive index of the tissue via an elasto-optic effect. The amount of refractive index modulation depends on the acoustic pressure intensity, and the shape of the area of modified refractive index is defined by the geometry of the ultrasonic wave. The volume of tissue where this gradient of refractive index is acts as an "acoustic lens" 108 whose optical power varies in time at the ultrasonic frequency. The strongest refractive index modulation occurs in the focal point 109 of the ultrasonic beam.

A fraction of light emitted from the florescent dye is transmitted through the ultrasonic focal point 109 of the acoustic lens 108 and gets optically modulated at the ultrasonic frequency. The physical mechanism of the modulation is a deflection of the transmitted photon from its original direction by the acoustic lens. The strongest ultrasonic induced modulation occurs when the ultrasonic focal point is located half way between the object of interest 120 and a plane of optical detection.

Alternatively, the ultrasonic beam may be formed before the excitation light reaches the object of interest 120. In this situation, the excitation light will be optically modulated before it excites the fluorescence in the object of interest, and therefore, the light emitted by the fluorescence in the object of interest will be modulated at the ultrasonic frequency of the ultrasonic generation system 106.

When the acoustically modulated light reaches the surface of the biological tissue 104, it can be detected using the detection system 110. A variety of optical detectors can be used for the detection of ultrasonic modulated light such as: a single optical detector 234 such as a photodetector, photomultiplier tube (PMT), photodiode; arrays

of photodetectors; or full field optical detectors such as charge-coupled device (CCD) cameras. The optical energy can be delivered to the detectors via free-space imaging optics such as a collection optic 230 and optical filter 232, optical fibers and/or through fiber bundles. An efficient detection of ultrasonic induced modulation requires blocking of excitation light that can be done using optical filtering techniques. One or more optical filters 232 may also be provided to reject light that is not fluorescent emission, and accept light that is fluorescent emission. The detection system 110 further includes an amplifier 236 for amplifying the detected optical signal received from detector 234 and a bandpass filter 238 for filtering the amplified signal before being sent to the data processing system 112. Preferably, the point of detection will be located at an approximately 90 degrees angle in relation to the ultrasonic transducer.

This optical signal, e.g., the time varying intensity of light, is acquired and stored for further processing for each position of the ultrasonic focal spot during the scan.

The modulated optical signal is detected using one or more of the following techniques: direct detection of the signal; a homodyne detection method wherein the gain of the optical signal is modulated at the ultrasonic frequency, and the phase between the optical gain and the ultrasound is swept over a range of angles; a heterodyne detection method wherein the gain of the optical signal is modulated at some frequency that is different than the ultrasound frequency, and the amplitude of the signal at the side lobes is measured; a shuttering detection method that integrates the optical signal at a particular phase in the ultrasonic modulation over many acoustic cycles, wherein the optical signal is then integrated at one or more different phases over many acoustic cycles, and the modulated light signal is extracted by comparison of these integrated signals; or a double cross correlation technique that performs a correlation analysis of the detected optical signal against the illumination input signal and the acoustic input signal to measure the amplitude of the signal for optimal noise rejection.

The data collected by the optical detectors will then be sent to the data processing system 112. It is to be understood that the data processing system 112 may be

implemented in various forms of hardware, software, firmware, special purpose processors, or a combination thereof. In one embodiment, the data processing system 112 may be implemented in software as an application program tangibly embodied on a program storage device. The application program may be uploaded to, and executed by, a machine comprising any suitable architecture. Preferably, the machine is implemented on a computer platform having hardware such as one or more central processing units (CPU), a random access memory (RAM), a read only memory (ROM) and input/output (I/O) interface(s) such as a keyboard, cursor control device (e.g., a mouse) and display device. The computer platform also includes an operating system and micro instruction code. The various processes and functions described herein may either be part of the micro instruction code or part of the application program (or a combination thereof) which is executed via the operating system. In addition, various other peripheral devices may be connected to the computer platform such as an additional data storage device and a printing device.

It is to be further understood that, because some of the constituent system components and method steps depicted in the accompanying figures may be implemented in software, the actual connections between the system components (or the process steps) may differ depending upon the manner in which the present invention is programmed. Given the teachings of the present invention provided herein, one of ordinary skill in the related art will be able to contemplate these and similar implementations or configurations of the present invention.

The location of the fluorescent dye can be determined from a data set obtained during ultrasonic scan over the volume of the biological tissue. Initially in step 302, the excitation light source 102 will illuminate the scattering medium 104. A two-dimensional (2D) scanning of a volume of the scattering medium 104 will be performed for NxM steps along an X and Y axis of the scattering medium 104. After the scattering medium is illuminated, the transducer 210 and detector 234 are moved to the j-position along the X axis (step 304) and, similarly, are moved to the i-position along the Y axis (step 306). Once the proper position is located, the transducer 230 is fired to induce the acoustic lens (step 308).

Detector 234 will detect an optical signal generated via the acoustical lens and the optical signal will be sent to the data processing system to acquire an ultrasonic trace (step 310). A time window is applied to the ultrasonic trace to extract a signal corresponding to an arrival of the ultrasonic wave to the focal point of the acoustic lens (step 312). Next, a fast Fourier transform (FFT) is performed on the windowed signal (step 316) and an amplitude of the signal is measured at the ultrasound frequency (step 316). The measured amplitude is then assigned a grey level of the i - j pixel of the image to be generated (step 318).

The method will then check if N scans have been taken along the i -position on the Y -axis (step 320). If it is less than N , the method will return to step 306, the transducer 210 and detector 234 will be move to the next position along the Y -axis and steps 308 through 318 will be repeated. Similarly, the method will then check if M scans have been taken along the j -position on the X -axis (step 322). If j is less than M , the method will return to step 304, the transducer 210 and detector 234 will be move to the next position along the X -axis and steps 308 through 318 will be repeated.

Referring to FIG. 4, the use of multiple illumination points and detection points is illustrated. In FIG. 4, S represents an excitation light source at a specific point on the volume and D represents a detector for acquiring an optical signal at the specified point, where an exemplary detected signal is associated with each detector. To acquire the multiple detected signals, a signal detector 234 may be utilized in conjunction with switch 550. Switch 550 will be connected to several detector point D_1 through D_n which will be coupled to the detector 234 depending on a position of the switch 550, as shown in FIG. 5. Optionally, the switch will be coupled to and controlled by the data processing system 112. Alternatively, multiple detectors will be located on the surface of the scattering medium 104 and switch 660 will couple individual detectors 234 to the data processing system.

Similarly, to generate ultrasonic pulses at different locations and induce acoustic lens at varying angles, multiple transducers 210 may be located at multiple points and coupled to the arbitrary function generator 214 via switch 770.

When all the scans have been acquired, an image localizing the object of interest will be created and displayed on the display or saved to memory (step 324). This can be done using the measured amplitude of the US modulated signal and ultrasonic time-of-flight for each scan location; measured depth of modulation as a function of focal-spot-to-detector distance; or known focal-spot-to-detector geometry.

The reconstruction algorithm for the fluorescent optical image may be any one of the following conventional techniques: Solution by direct inversion of a linear description of the forward model; Solution by iterative optimization of a nonlinear description of the forward model; Solution by direct solution of a nonlinear description of the forward model.

To illustrate the principles of the present disclosure, the following experiment was preformed. A 0.1 ml of micro-molar solution of Rhodamine 6G (maximal emission ~ 570 nm) was injected into a transparent gel to form a fluorescent-marked area, e.g., an object of interest, approximately 1 mm in diameter and 5 mm length. A rectangular plastic cuvette with the gel was immersed into a water tank, e.g., a scattering medium. The fluorescence was excited using frequency-doubled YAG laser ($\lambda=532$ nm, optical power 10 mW), which beam was expanded by 10x microscope objective. An immersed PZT transducer (focal length 50 mm, diameter 25 mm) was excited by 10 tonebursts of 2MHz frequency. Focal point of the transducer was located on axis between the fluorophore and optical detector at 20 mm distance from the fluorophore. The fluorescent light was collected by 50 mm lens on an amplified Si- photodetector, e.g., a model PDA55 commercially available from Thorlabs of New Jersey. An interference band-reject optical filter with OD=6 at $\lambda=532$ nm was placed in front of the photodetector to block the excitation light. Overall optical power of the fluorescent light at the photodetector was ~20 nW, the level of ambient light and excitation light leakage were below 1 nW. The photodetector signal was amplified by 54 dB using a broadband RF amplifier, commercially available from GE Panametrics, of Waltham, MA, band-pass filtered, digitized and averaged 512 times by a digital oscilloscope.

A typical acquired waveform and its spectrum are shown in FIG. 9. This experiment demonstrates the existence of the effect of ultrasonic tagging of fluorescence. The time delay of the detected signal corresponds to an arrival time of the ultrasonic toneburst to the acoustic focal point, that was verified by small axial displacement of the transducer. The spectrum of the signal shows that the power of 2.0 MHz signal within a 5 μ s time window where the detected signal is present is significantly stronger than a 2.0 MHz component in a 5 μ s time window taken earlier where just noise is present. This experiment clearly demonstrates the existence of the effect of ultrasonic tagging of fluorescence in a transparent medium.

Referring to FIG. 8, a hand-held imaging device 800 is illustrated. The imaging device 800 includes an excitation light source for illuminating the scattering medium. Preferably, light from the excitation light source is transmitted to a surface of the scattering medium via an optical fiber 840; in this way, the source can be located remotely from the device to conserve space in the device 800.

The imaging device includes a phased array of ultrasonic transducers 842 for inducing an acoustical lens 108 in the scattering medium. Light modulated by the acoustical lens is preferably detected by a second optical fiber 844 coupled to a detection system for acquiring ultrasonic traces.

A system and method for the localization of fluorescent dyes in a scattering medium are provided. The system and method provides for increased optical image resolution; simultaneous anatomical imaging (using ultrasonic scan data) and functional imaging (using optical data); decreased optical reconstruction complexity and required computation time, while utilizing non-ionizing radiation.

While the disclosure has been illustrated and described in typical embodiments, it is not intended to be limited to the details shown, since various modifications and substitutions can be made without departing in any way from the spirit of the present disclosure. As such, further modifications and equivalents of the disclosure herein disclosed may occur to persons skilled in the art using no more than routine

experimentation, and all such modifications and equivalents are believed to be within the spirit and scope of the disclosure as defined by the following claims.

WHAT IS CLAIMED IS:

1. A method for localization of fluorescence (120) in a scattering medium (104), the method comprising the steps of:

illuminating the scattering medium with an excitation light (102) to excite the fluorescence (120);

modulating a portion of the emitted light from the fluorescence within the scattering medium using an ultrasonic pulse;

detecting the modulated optical signal at a surface of the scattering medium (104).

2. The method as in claim 1, further comprising the step of reconstructing a spatial distribution of the fluorescence in the scattering medium from the detected signal.

3. The method as in claim 1, wherein the modulating step is performed by an ultrasonically induced gradient of refractive index (108).

4. The method as in claim 1, wherein the ultrasonically induced pressure gradient (108) is shaped as a single ultrasonic focal spot, an array of focal spots situated along a single line, an elongated linear ultrasonic focal region oriented along an optical source-to-receiver axis, a superposition of two or more ultrasonic beams to form an acoustic interference pattern at the same frequency or a superposition of two or more ultrasonic beams at the different frequencies.

5. A system for localization of fluorescence (120) in a scattering medium (104) comprising:

an excitation light source (102) for illuminating the scattering medium (104);

a fluorescent dye (120) within a preselected region of the scattering medium (104) for absorbing and emitting light in the NIR (near infrared) region of the light spectrum;

an ultrasonic scanning system (106) for generating ultrasonic pulses, wherein the ultrasonic pulses modulate the emitted light from the fluorescent dye; and

an optical detection system (110) for detecting the modulated light.

6. The system as in claim 5, further comprising a data processing system (112) acquiring the detected optical signal and generating a spatial distribution of the fluorescence in the scattering medium based on the detected optical signals.

7. The system as in claim 5, wherein the fluorescent dye (120) is Indocyanine green (ICG), a member of the Cy family of dyes, IR-78 dye or a fluorophore that emits in the NIR region of light.

8. The system as in claim 5, wherein the optical detection system further comprises:

a light collection and delivery system for collecting light emitted;

at least one optical filter for filtering the light and allowing transmission of fluorescent emission; and

a detector (234) for converting optical signals to electrical signals capable of being read by the data processing system.

9. The system as in claim 8, wherein the light collection and delivery system includes at least one optical fiber for delivering collected light from the scattering medium to the detector.

10. The system as in claim 8, wherein the detector (234) is photodetector, photomultiplier tube (PMT), image intensifier, charge-coupled device or an array of photosensitive elements.

Fig. 1  100

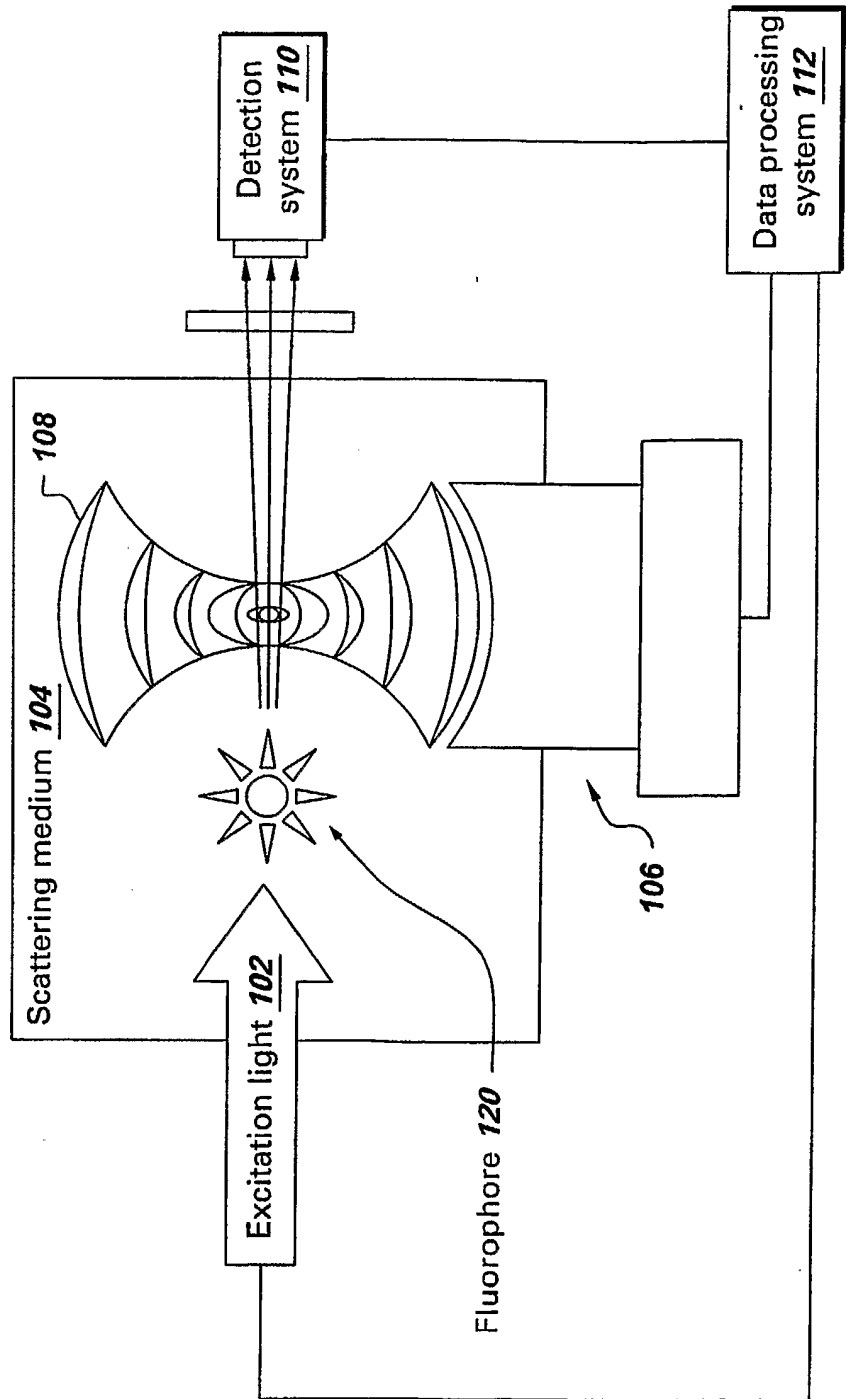

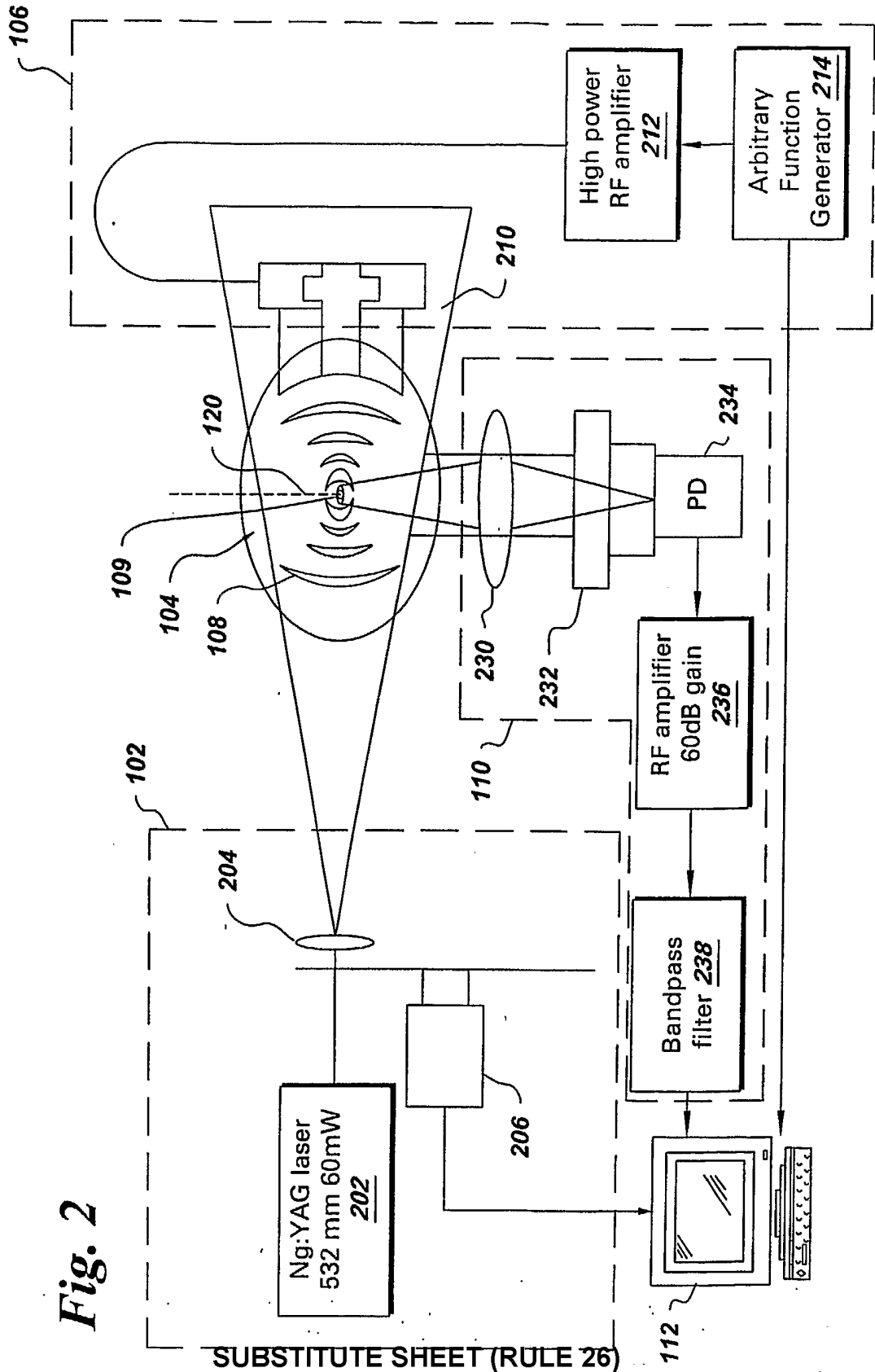

3/7

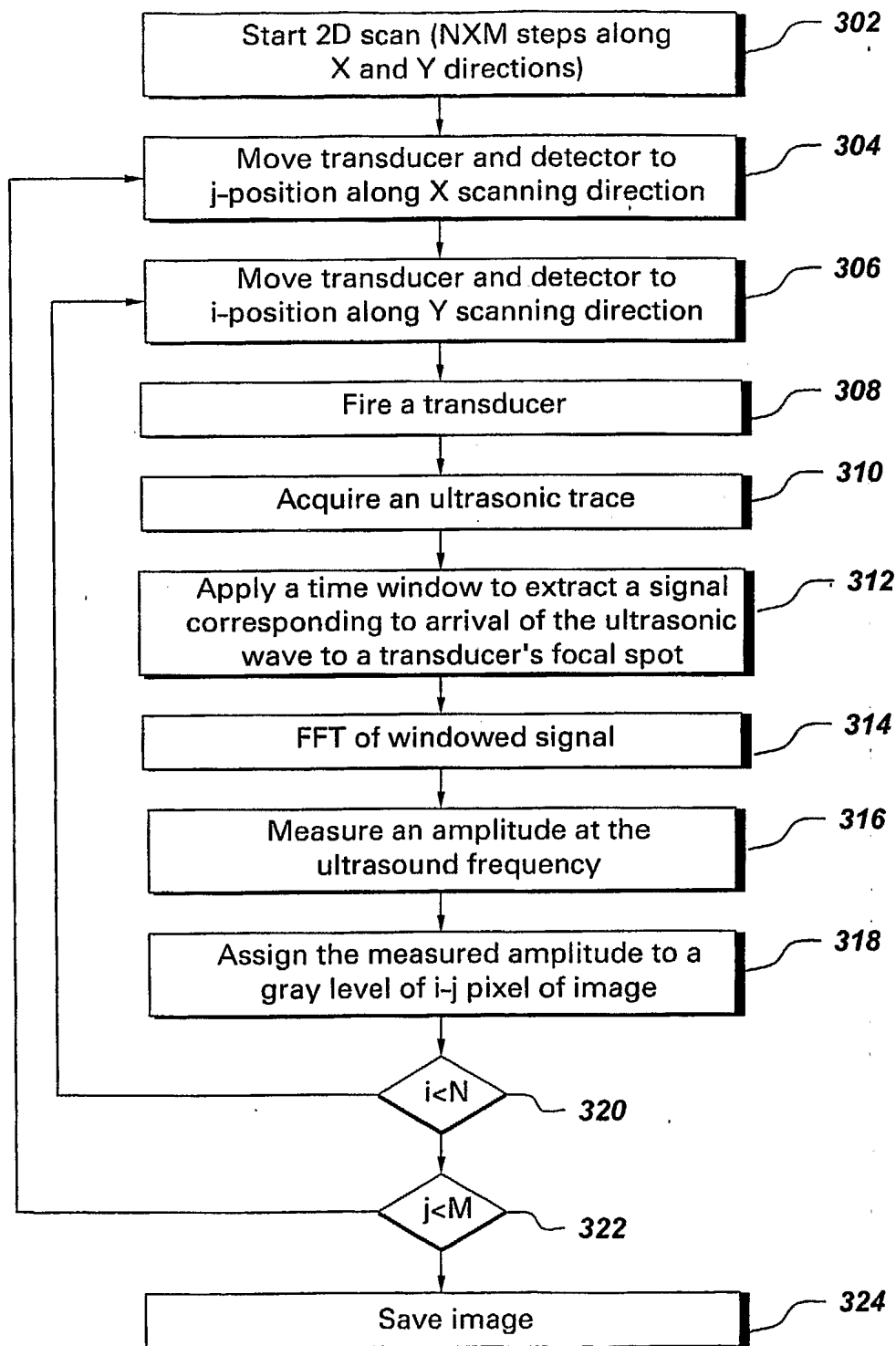

Fig. 3

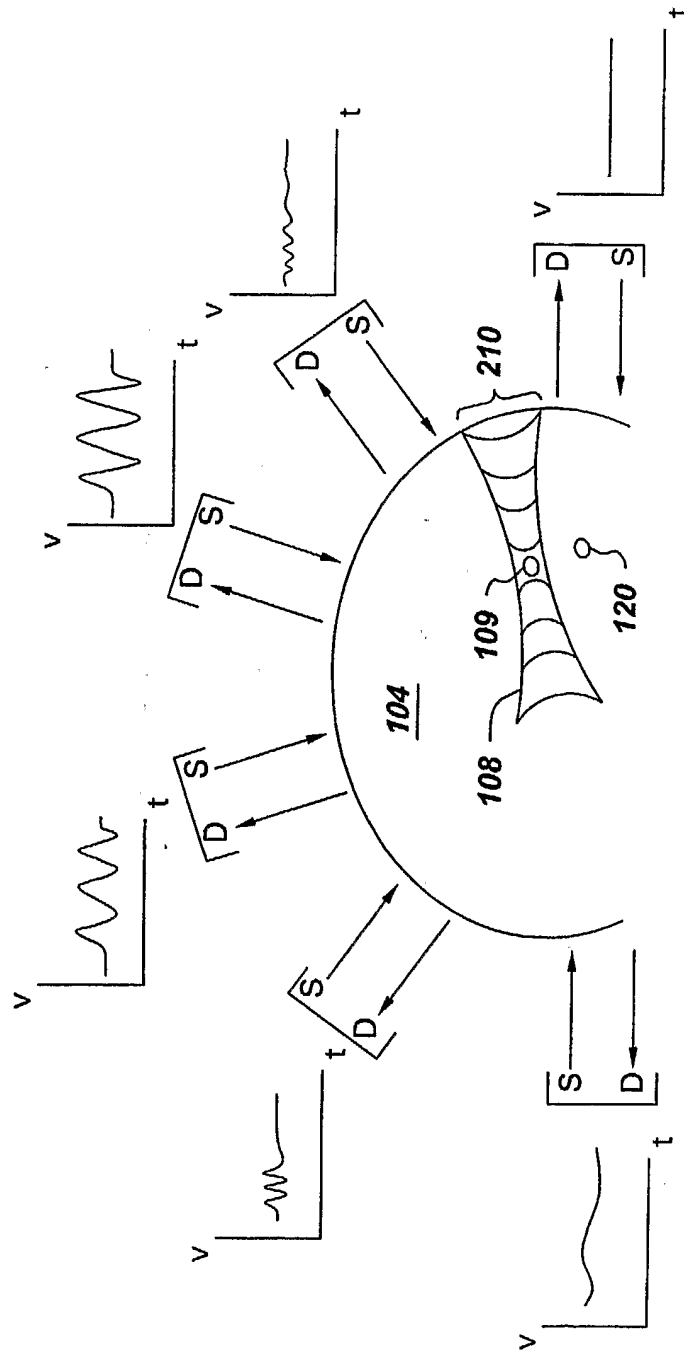
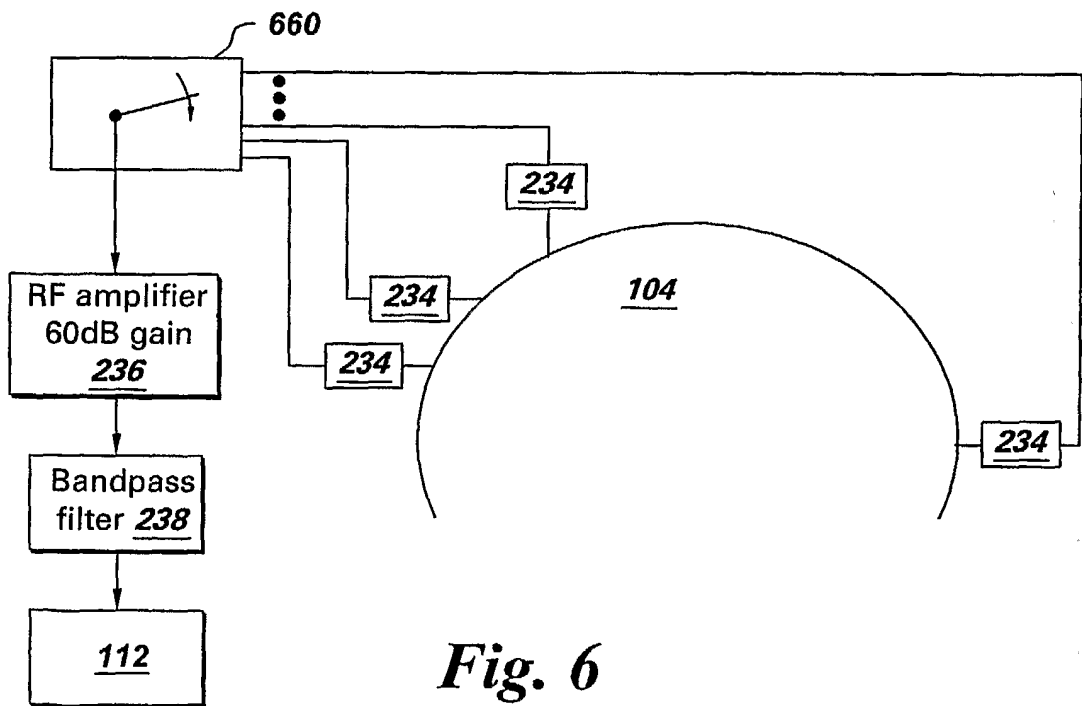
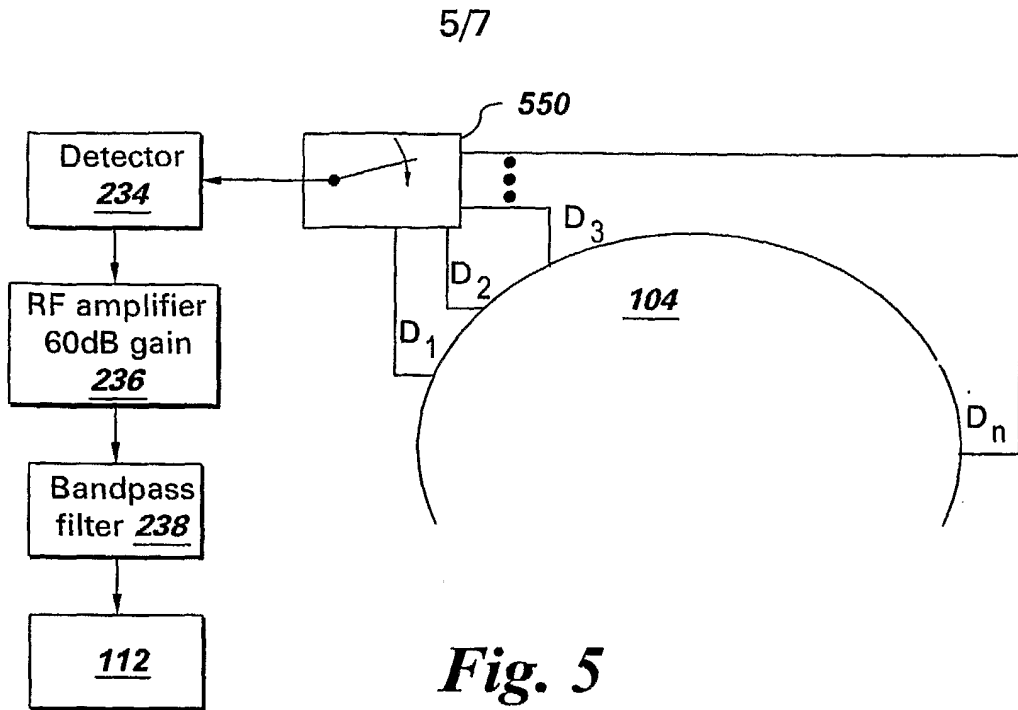

Fig. 4

SUBSTITUTE SHEET (RULE 26)



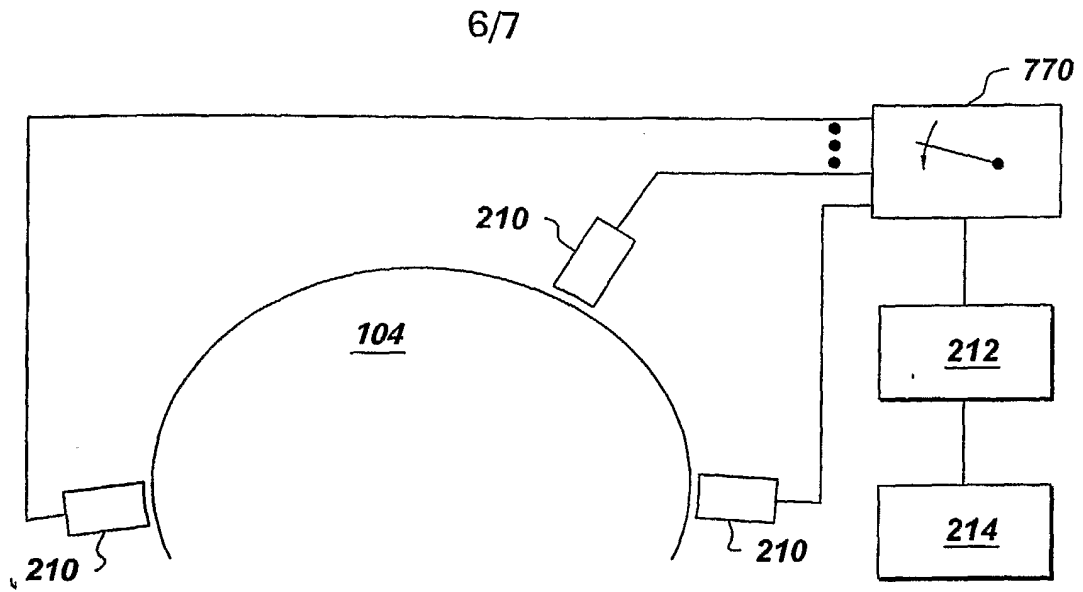

Fig. 7

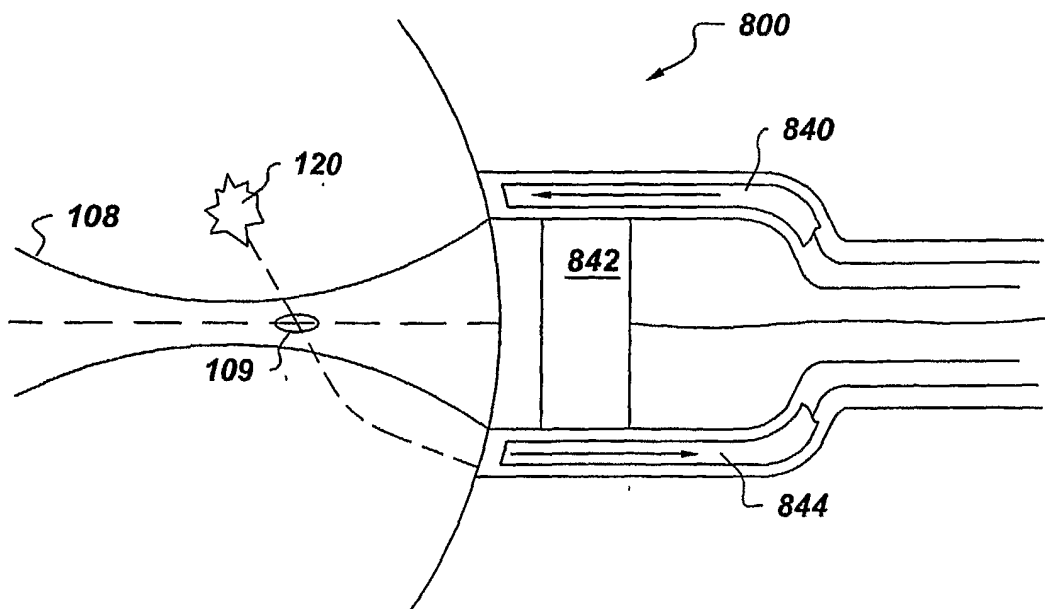

Fig. 8

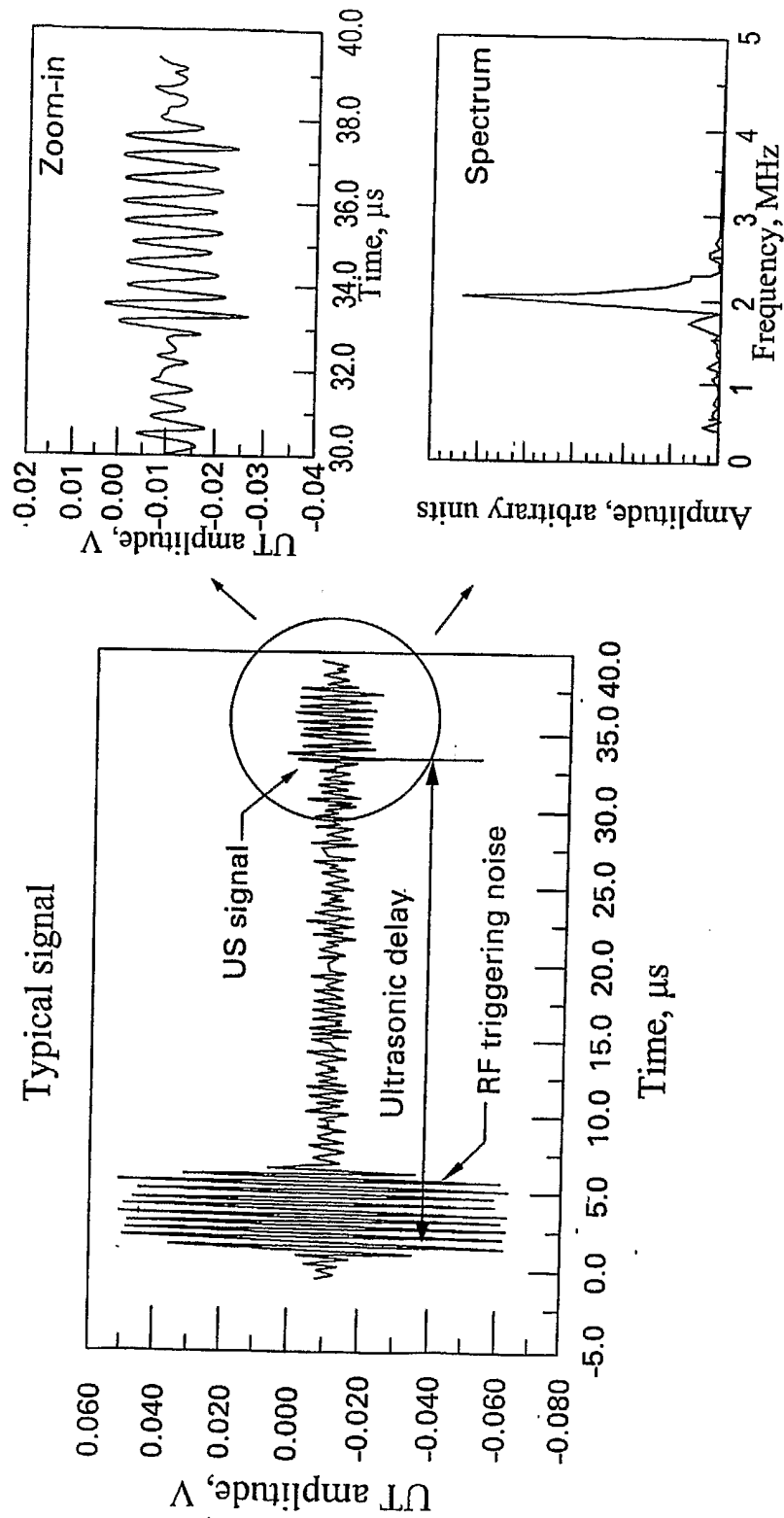

Fig. 9

INTERNATIONAL SEARCH REPORT

International Application No
PCT/US2004/038599

A. CLASSIFICATION OF SUBJECT MATTER
 IPC 7 G01N21/47 G01N21/17 A61B5/00

According to International Patent Classification (IPC) or to both national classification and IPC

B. FIELDS SEARCHED

Minimum documentation searched (classification system followed by classification symbols)
 IPC 7 G01N A61B

Documentation searched other than minimum documentation to the extent that such documents are included in the fields searched

Electronic data base consulted during the international search (name of data base and, where practical, search terms used)
 EPO-Internal, INSPEC, BIOSIS

C. DOCUMENTS CONSIDERED TO BE RELEVANT

Category °	Citation of document, with indication, where appropriate, of the relevant passages	Relevant to claim No.
X	US 4 407 008 A (SCHMIDT ET AL) 27 September 1983 (1983-09-27) column 4, line 46 - line 68 column 8, line 64 - column 9, line 30; figure 1 -----	1-10
X	US 5 999 836 A (NELSON ET AL) 7 December 1999 (1999-12-07) column 10, line 60 - column 12, line 51 column 14, line 5 - line 7 column 20, line 3 - column 21, line 6 column 25, line 8 - line 39 ----- -/--	1-10

Further documents are listed in the continuation of box C. Patent family members are listed in annex.

° Special categories of cited documents :

<p>*A* document defining the general state of the art which is not considered to be of particular relevance</p> <p>*E* earlier document but published on or after the international filing date</p> <p>*L* document which may throw doubts on priority claim(s) or which is cited to establish the publication date of another citation or other special reason (as specified)</p> <p>*O* document referring to an oral disclosure, use, exhibition or other means</p> <p>*P* document published prior to the international filing date but later than the priority date claimed</p>	<p>*T* later document published after the international filing date or priority date and not in conflict with the application but cited to understand the principle or theory underlying the invention</p> <p>*X* document of particular relevance; the claimed invention cannot be considered novel or cannot be considered to involve an inventive step when the document is taken alone</p> <p>*Y* document of particular relevance; the claimed invention cannot be considered to involve an inventive step when the document is combined with one or more other such documents, such combination being obvious to a person skilled in the art.</p> <p>* & * document member of the same patent family</p>
--	--

Date of the actual completion of the international search 7 March 2005	Date of mailing of the international search report 16/03/2005
--	---

Name and mailing address of the ISA European Patent Office, P.B. 5818 Patentlaan 2 NL - 2280 HV Rijswijk Tel. (+31-70) 340-2040, Tx. 31 651 epo nl, Fax: (+31-70) 340-3016	Authorized officer Duijs, E
--	---

INTERNATIONAL SEARCH REPORT

International Application No
PCT/US2004/038599

C.(Continuation) DOCUMENTS CONSIDERED TO BE RELEVANT		
Category °	Citation of document, with indication, where appropriate, of the relevant passages	Relevant to claim No.
X	<p>US 6 216 540 B1 (NELSON ROBERT S ET AL) 17 April 2001 (2001-04-17) column 4, line 44 - column 10, line 65 column 12, line 32 - line 42 column 21, line 56 - column 22, line 28 column 41, line 11 - line 12</p>	1-10
A	<p>MARKS F A ET AL: "A comprehensive approach to breast cancer detection using light: photon localization by ultrasound modulation and tissue characterizatoin by spectral discrimination" PROCEEDINGS OF THE SPIE, SPIE, BELLINGHAM, VA, US, no. 1888, 17 January 1993 (1993-01-17), pages 500-510, XP002074940 ISSN: 0277-786X cited in the application the whole document</p>	1-6,8-10
A	<p>US 6 167 297 A (BENARON ET AL) 26 December 2000 (2000-12-26) column 4, line 13 - column 5, line 31; claims 6,25</p>	1,5,7

INTERNATIONAL SEARCH REPORT

information on patent family members

International Application No
PCT/US2004/038599

Patent document cited in search report		Publication date		Patent family member(s)	Publication date
US 4407008	A	27-09-1983	DE	3037983 A1	22-04-1982
			EP	0056426 A2	28-07-1982
			JP	1609376 C	28-06-1991
			JP	2026177 B	07-06-1990
			JP	57091445 A	07-06-1982
US 5999836	A	07-12-1999	US	6216540 B1	17-04-2001
			US	6345194 B1	05-02-2002
US 6216540	B1	17-04-2001	US	5999836 A	07-12-1999
			US	6345194 B1	05-02-2002
US 6167297	A	26-12-2000	AU	3926900 A	21-11-2000
			EP	1196763 A1	17-04-2002
			JP	2002543859 T	24-12-2002
			WO	0068665 A1	16-11-2000
			US	6246901 B1	12-06-2001