

E. Beach,

Wrench.

No. 112,108.

Patented Feb. 28. 1871.

Fig. 1.

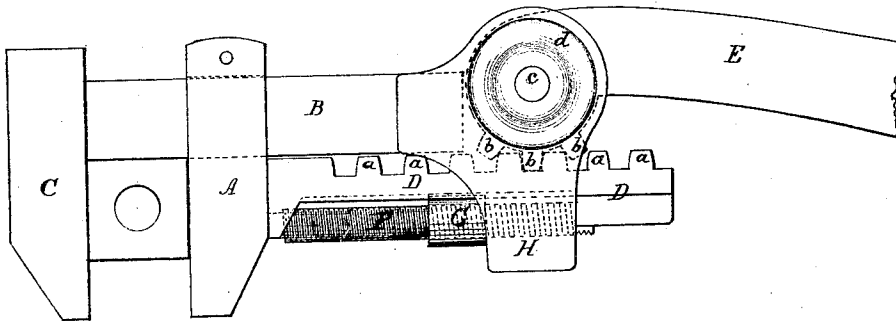
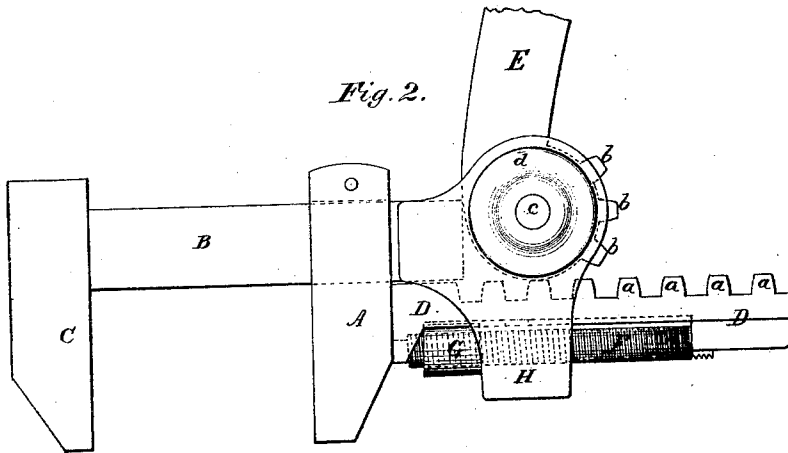

Fig. 2.



Witnesses:

Wm. Hamilton Johnson
E. A. Dick

Inventor:

Elias Beach
By his Attorneys
Apperman & Johnson

United States Patent Office.

ELIAS BEACH, OF TITUSVILLE, PENNSYLVANIA.

Letters Patent No. 112,108, dated February 28, 1871.

IMPROVEMENT IN WRENCHES.

The Schedule referred to in these Letters Patent and making part of the same.

I, ELIAS BEACH, of Titusville, in the county of Crawford and State of Pennsylvania, have invented certain new and useful Improvements in Wrenches, of which the following is a specification.

My invention relates to that class of wrenches in which a movable jaw is operated by a pivoted lever handle; and

It consists in the combination of an independent traversing lock-nut with a screw on the shank of the movable jaw, and an abutment on the shank of the fixed jaw, for the purpose of constituting a lock to the movable jaw when set, so as to hold the wrench to its work by a device independent of the operating lever.

In the accompanying drawing—

Figure 1 represents an elevation of a wrench, showing the movable jaw clamped in position by the independent traversing lock-nut.

Figure 2 represents a similar view, showing the operating lever thrown out of gear with the movable jaw.

The movable jaw A of the wrench is made to slide upon the shank B of the fixed jaw C, so as to bite the nut or article to be turned in the usual manner.

The shank D of the movable jaw has cogs or teeth, *a*, on its side next to the fixed shank, into which match cogs, *b*, on the pivoted end of the lever handle E, by which the movable jaw is operated so as to open and close it with the fixed jaw by simply turning the handle E upon its pivot *c*, which passes through ears *d* on the rear end of the fixed shank.

The shank D of the movable jaw A carries a screw-stem, F, which moves with it, and is provided with an independent lock-nut, G, which traverses said screw F, and acts against a stop or abutment, H, on the rear end of the fixed shank B, so that as the movable jaw is made to bite upon the nut, it is held up tightly and securely to its work by bringing the lock-nut G against the abutment H, so that the tighter the jaws are clamped upon the article, the tighter they may be locked to their hold.

The lever handle E moves the adjustable jaw A in either direction through its cogged connection, when turned within a certain range of motion; but when the handle is brought to a position at right angles or nearly so to the fixed shank, the cogs *b* of the lever E will be disengaged from those of the shank, and thus allow the movable jaw to be adjusted as may be required before bringing the lever into gear, as shown in fig. 2.

This feature is of great advantage in applying the wrench, because it enables the lever handle to be in the best position for use with respect to the size of the nut.

The movable jaw is under the control of the handle E, so as to be operated by its cogs to either open or close the jaws, and the lock-nut simply traverses the screw to clamp the movable jaw against the abutment of the fixed jaw.

The locking of the movable jaw when clamped to the work is of great advantage in holding the wrench to its work, and at the same time allowing it to bite more firmly upon its work by the free action of the lever handle.

By this arrangement of the parts, the wrench can be operated in either direction, while obtaining all the advantages of a cogged lever-wrench.

Having thus described my invention,

I claim—

In a pivoted cogged lever-wrench, the arrangement and combination of the fixed abutment H, screw-stem F, traveling locking-nut G, rack D, and the fixed and movable jaws C and A, operating substantially as described.

In testimony whereof I have hereunto signed my name.

ELIAS BEACH.

Witnesses:

A. E. H. JOHNSON,
J. W. HAMILTON JOHNSON.