



US00RE44656E

(19) **United States**
(12) **Reissued Patent**
Becklin

(10) **Patent Number:** **US RE44,656 E**
(45) **Date of Reissued Patent:** **Dec. 24, 2013**

(54) **STACKABLE CONTAINER APPARATUS AND METHODS**

(75) Inventor: **Dennis M. Becklin**, Grants Pass, OR
(US)
(73) Assignee: **Becklin Holdings, Inc.**, Grants Pass, OR
(US)

(21) Appl. No.: **12/966,775**

(22) Filed: **Dec. 13, 2010**

Related U.S. Patent Documents

Reissue of:

(64) Patent No.: **7,740,138**
Issued: **Jun. 22, 2010**
Appl. No.: **12/171,970**
Filed: **Jul. 11, 2008**

U.S. Applications:

(62) Division of application No. 11/128,923, filed on May 12, 2005, now Pat. No. 7,537,119.

(51) **Int. Cl.**
B65D 21/036 (2006.01)
B65D 21/02 (2006.01)

(52) **U.S. Cl.**
CPC **B65D 21/0223** (2013.01); **B65D 21/0222** (2013.01)
USPC **206/508**; 220/23.83

(58) **Field of Classification Search**
USPC 206/507, 508, 509, 511, 504, 503;
220/23.86, 23.83, 23.6, 23.2, 781, 380;
29/525; D9/432, 430, 416
IPC B65D 21/036, 21/032, 21/02, 21/00
See application file for complete search history.

(56) **References Cited**

U.S. PATENT DOCUMENTS

879,455 A	2/1908	Frost et al.	
2,496,093 A *	1/1950	Iwata	215/10
2,695,115 A	11/1954	Roop et al.	
2,753,077 A *	7/1956	Greco	206/504
2,822,952 A *	2/1958	Scott	206/504
2,849,151 A	8/1958	Heil	
2,939,603 A	6/1960	Young	
3,103,278 A	9/1963	Kuzma et al.	
3,117,692 A	1/1964	Carpenter et al.	
3,383,009 A	5/1968	Weikert	
3,391,824 A	7/1968	Wiseman	
3,419,184 A	12/1968	Asenbauer	
3,481,502 A	12/1969	Slayman	
3,616,943 A	11/1971	Brink	
3,754,645 A	8/1973	Kilroy	

(Continued)

FOREIGN PATENT DOCUMENTS

EP	0129860	1/1985
JP	05254542	10/1993
JP	05254542 A *	10/1993

Primary Examiner — Robert J Hicks

(74) *Attorney, Agent, or Firm* — Lowe Graham Jones PLLC

(57) **ABSTRACT**

A stackable container assembly includes a lid portion having first raised members projecting outwardly from an upper surface, at least some of the first raised members cooperatively forming first receiving areas, and a base portion coupleable to the lid portion and forming a containment space. The base portion includes second raised members projecting outwardly from a lower surface, at least some of the second raised members cooperatively forming second receiving areas being adapted to fittingly receive first raised members of a like container assembly positioned below the lower surface. And, the first receiving areas are adapted to fittingly receive second raised members of another like container assembly positioned above the upper surface.

12 Claims, 6 Drawing Sheets

Amended

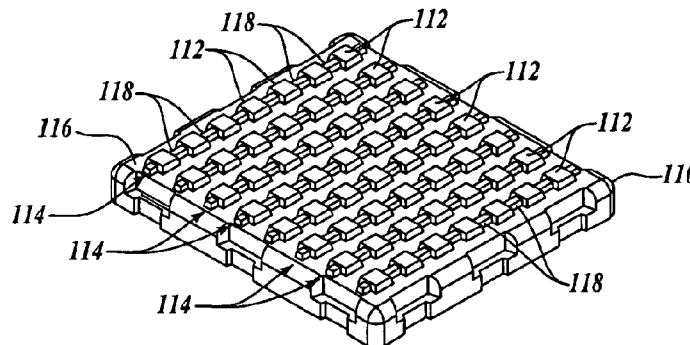

(56)

References Cited

U.S. PATENT DOCUMENTS

3,756,396 A	9/1973	Kilroy		5,454,477 A	10/1995	Bornhorst et al.	
3,759,416 A	9/1973	Constantine		5,566,824 A	10/1996	Tack et al.	
3,811,747 A	5/1974	Levin		5,641,090 A	6/1997	Kowalski et al.	
3,968,879 A	7/1976	Lucas, Sr. et al.		5,718,350 A	2/1998	Williams	
4,287,997 A	9/1981	Rolfe et al.		5,769,230 A	6/1998	Koefeld	
4,373,633 A *	2/1983	Lutz, Sr.	206/508	5,779,051 A	7/1998	Boutin	
4,480,748 A *	11/1984	Wind	206/386	D420,396 S *	2/2000	Vieslet	D21/690
4,655,360 A	4/1987	Juhanson		6,021,916 A	2/2000	Stolzman	
4,647,411 A	6/1987	Rehrig et al.		6,085,467 A	7/2000	Packrall et al.	
4,671,411 A	6/1987	Rehrig et al.		6,186,345 B1	2/2001	Robertson	
4,765,252 A	8/1988	Shuert		6,237,758 B1	5/2001	Hsu	
4,832,200 A	5/1989	Deaton et al.		D446,017 S	8/2001	Koefeld	
4,848,605 A	7/1989	Wise		6,308,858 B1	10/2001	Koefeld	
5,042,674 A *	8/1991	Ramsay et al.	220/4.24	6,367,630 B1	4/2002	Elskamp	
D333,094 S	2/1993	Zutler		6,371,364 B1	4/2002	Maillot et al.	
D333,978 S *	3/1993	Zutler	D9/743	6,457,599 B1	10/2002	Apps et al.	
5,203,494 A	4/1993	Blomfield		6,585,090 B2	7/2003	Harvey	
5,224,635 A *	7/1993	Wise	222/608	6,662,950 B1	12/2003	Cleaver	
5,392,945 A	2/1995	Syrek		D500,924 S	1/2005	Martin et al.	
D361,715 S	8/1995	Haupt		7,163,122 B2	1/2007	Elder et al.	
				2004/0178208 A1	9/2004	Leba et al.	
				2005/0199623 A1 *	9/2005	Elder et al.	220/4.28
				2006/0254947 A1	11/2006	Rogers	

* cited by examiner

Amended

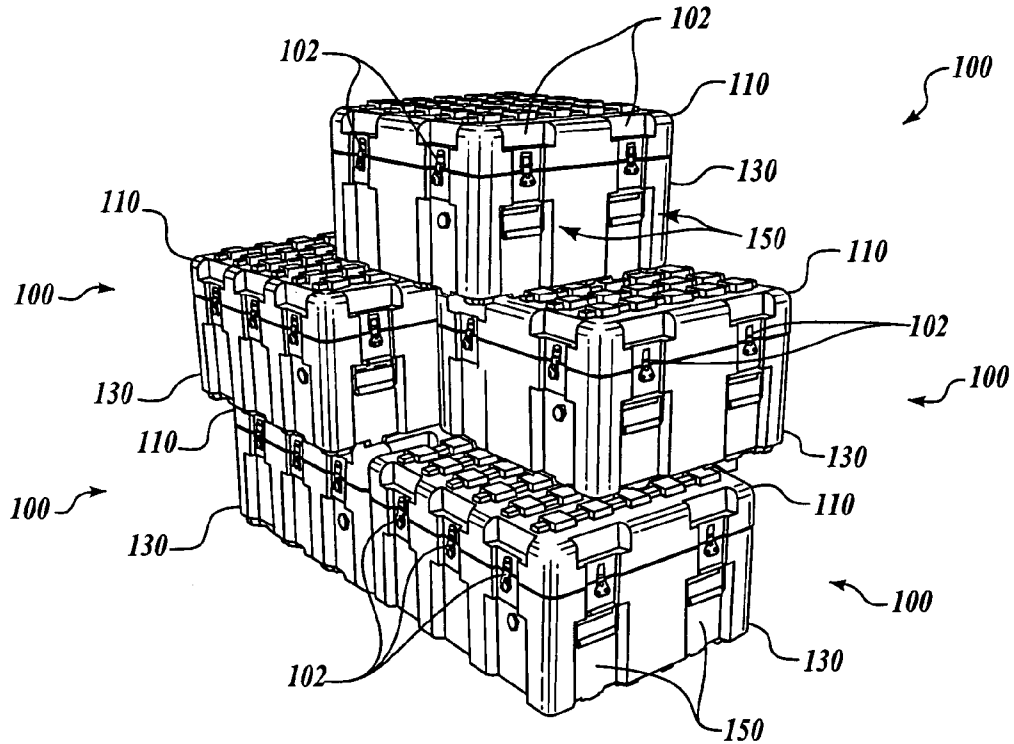

FIG. 1

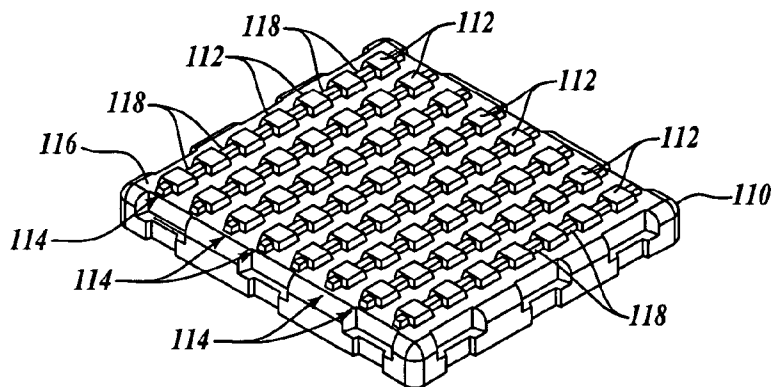

FIG. 2

Amended

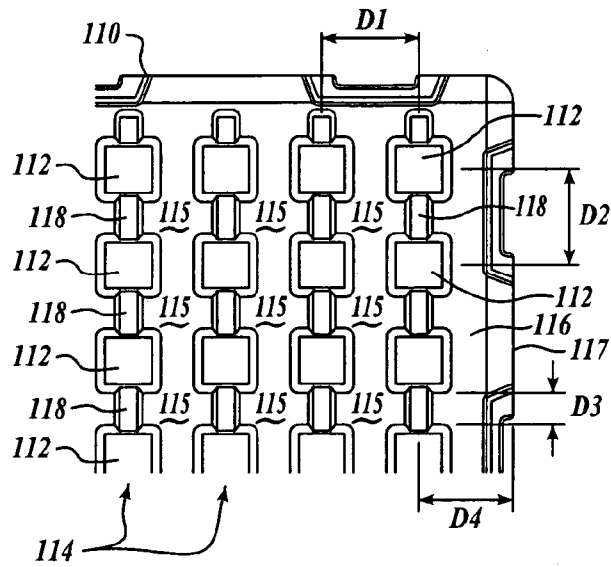

FIG. 3

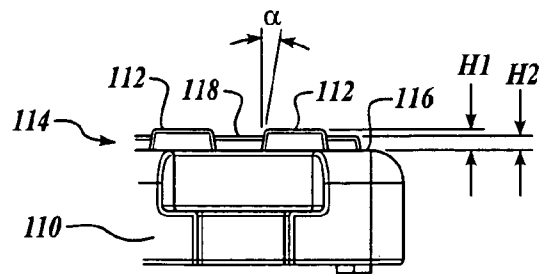

FIG. 4

Amended

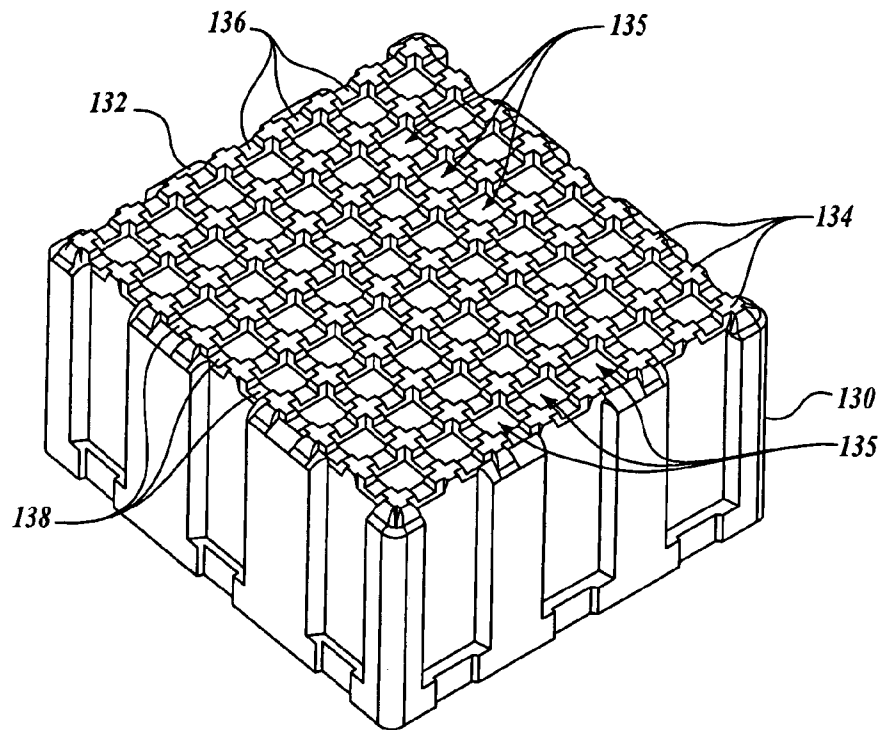

FIG. 5

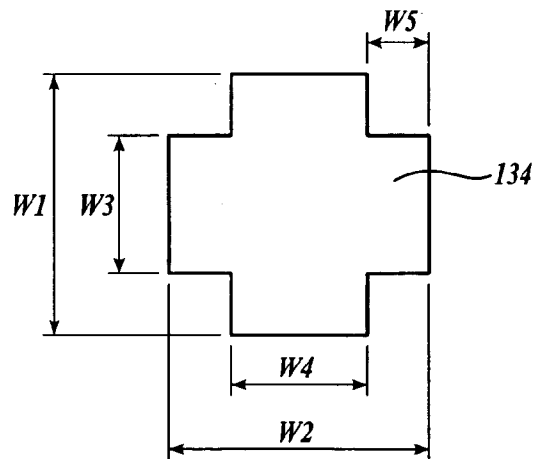

FIG. 6

Amended

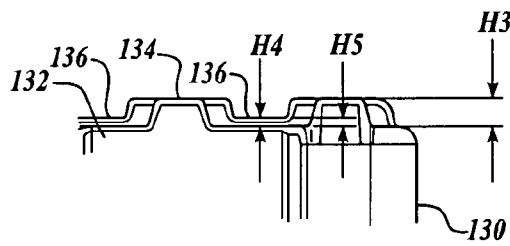

FIG. 7

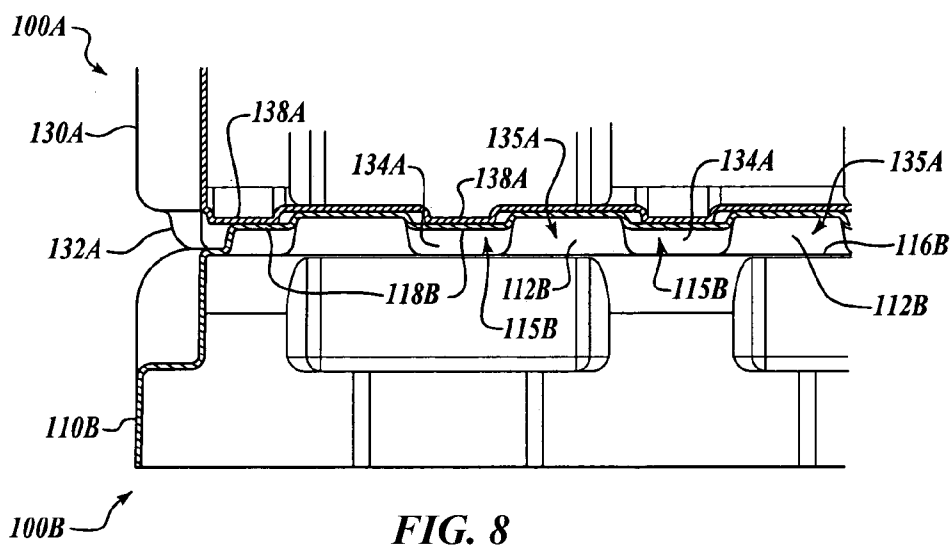
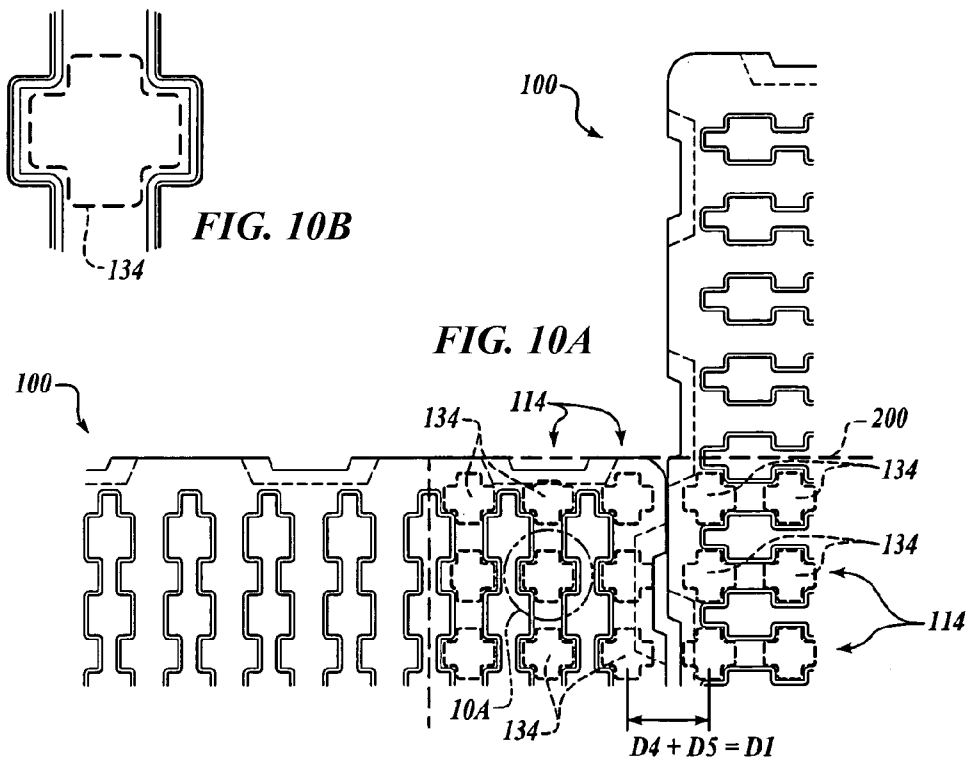
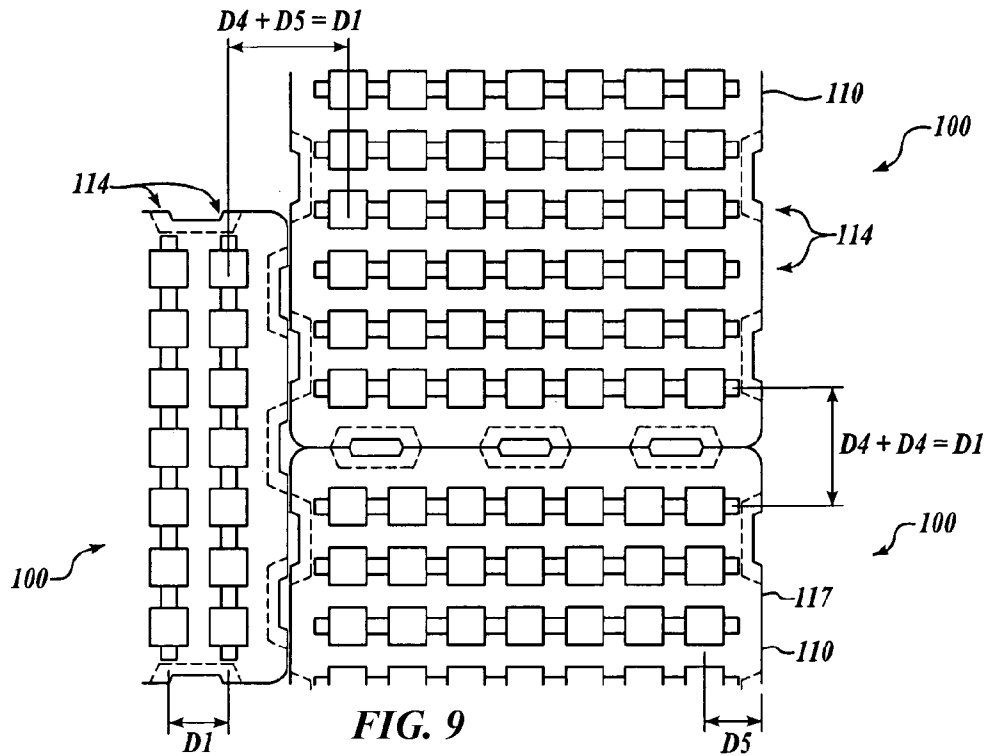

FIG. 8

Amended



Amended

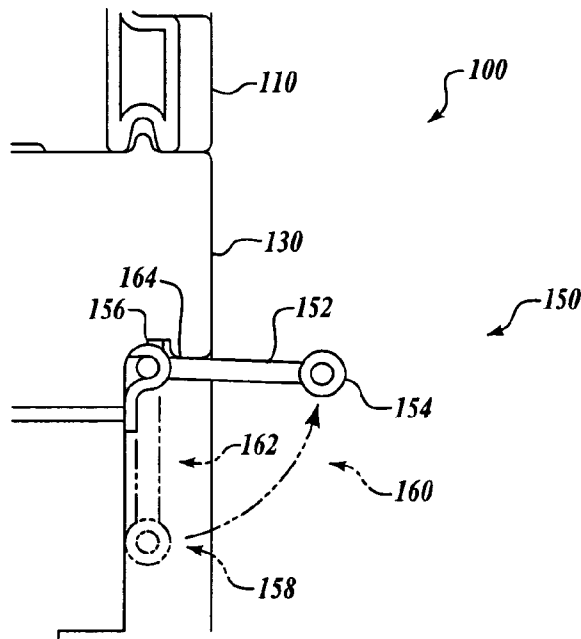

FIG. 11

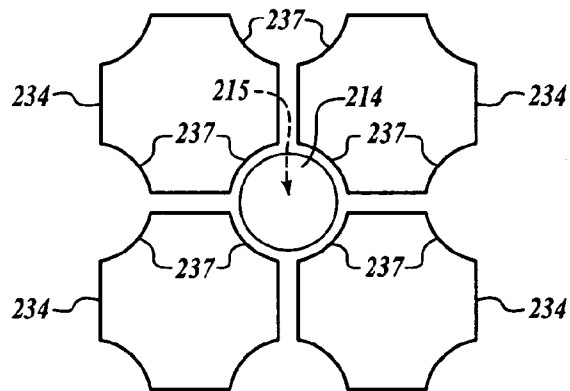

FIG. 12

STACKABLE CONTAINER APPARATUS AND METHODS

Matter enclosed in heavy brackets [] appears in the original patent but forms no part of this reissue specification; matter printed in italics indicates the additions made by reissue.

PRIORITY CLAIM

This application is a divisional of pending U.S. patent application entitled "STACKABLE CONTAINER APPARATUS AND METHODS", and assigned U.S. Ser. No. 11/128,923, filed on May 12, 2005, *now U.S. Pat. No. 7,537,119*.

FIELD OF THE INVENTION

This invention relates to containers for storing and transporting products, such as electronics equipment, and more specifically, to stackable container apparatus and methods.

BACKGROUND OF THE INVENTION

A wide variety of products are stored and transported in containers. It is often desirable to stack the containers during storage and transport to effectively utilize the available space within the storage facility or the transport vehicle. A variety of containers are known which provide some capability to be stacked, including the various containers disclosed, for example, in U.S. Pat. No. 6,457,599 B1 issued to Apps et al., U.S. Pat. No. 6,237,758 B1 issued to Hsu, U.S. Pat. No. 6,186,345 B1 issued to Robertson, U.S. Pat. No. 6,085,467 issued to Packrall et al., U.S. Pat. No. 5,769,230 issued to Koefeld, U.S. Pat. No. 5,203,494 issued to Blomfield, and U.S. Pat. No. 4,655,360 issued to Juhanson. Although desirable results have been achieved using such prior art containers, there is room for improvement.

SUMMARY OF THE INVENTION

The present invention is directed to stackable container apparatus and methods. Embodiments of apparatus and methods in accordance with the present invention may advantageously provide an improved capability to stack a plurality of containers in a secure, non-sliding manner, and may substantially improve a user's ability to store products, and may also reduce or eliminate the need for specially-crafted foam inserts, in comparison with prior art containers.

In one embodiment, a container assembly in accordance with the invention includes a lid portion and a base portion coupleable to the lid portion and forming a containment space. The lid portion has an upper surface and includes a plurality of first raised members projecting outwardly from the upper surface, at least some of the first raised members cooperatively forming a plurality of first receiving areas. Similarly, the base portion has a lower surface and includes a plurality of second raised members projecting outwardly from the lower surface, at least some of the second raised members cooperatively forming a plurality of second receiving areas. The second receiving areas are adapted to fittingly receive a second plurality of first raised members of a like container assembly positioned below the lower surface, and the first receiving areas are adapted to fittingly receive a

second plurality of the second raised members of another like container assembly positioned above the upper surface.

BRIEF DESCRIPTION OF THE DRAWINGS

Preferred and alternate embodiments of the invention are described in detail below with reference to the following drawings.

FIG. 1 is an isometric view of a plurality of stackable containers in accordance with an embodiment of the invention;

FIG. 2 is an isometric view of a lid portion of a stackable container of FIG. 1 in accordance with an embodiment of the invention;

FIG. 3 is an enlarged, partial top elevational view of the lid portion of FIG. 2;

FIG. 4 is an enlarged, partial side elevational view of the lid portion of FIG. 2;

FIG. 5 is an isometric view of a base portion of the stackable container of FIG. 1 in an inverted position in accordance with an embodiment of the invention;

FIG. 6 is an enlarged, top elevational view of a stacking cleat of the base portion of FIG. 5;

FIG. 7 is an enlarged, side elevational view of the stacking cleat of FIG. 5;

FIG. 8 is an enlarged side elevational view of an upper stackable container engaged with a lower stackable container in accordance with an embodiment of the invention;

FIG. 9 is a top elevational view of a plurality of stackable containers of FIG. 1;

[FIG. 10] FIG. 10A is an enlarged top elevational view of an upper stackable container engaged with the plurality of lower stackable containers in accordance with a further embodiment of the invention;

FIG. 10B is a close-up view of a raised cleat from FIG. 10A;

FIG. 11 is an enlarged, side elevational view of a handle assembly of a stackable container in accordance with yet another embodiment of the invention; and

FIG. 12 is a top elevational view of a first raised member received into an approximately circular receiving area formed by a plurality of second raised members in accordance with an alternate embodiment of the invention.

DETAILED DESCRIPTION

The present invention relates to stackable container apparatus and methods. Many specific details of certain embodiments of the invention are set forth in the following description and in FIGS. 1-12 to provide a thorough understanding of such embodiments. The present invention may have additional embodiments, or may be practiced without one or more of the details described for any particular described embodiment.

FIG. 1 is an isometric view of a plurality of stackable containers 100 in accordance with an embodiment of the invention. In this embodiment, each stackable container 100 includes a lid portion 110 that is removably coupled to a base portion 130 by a plurality of latches 102. The base portion 130 includes a plurality of handle assemblies 150 to facilitate lifting and transport of the container 100.

In one particular embodiment, the stackable containers 100 are formed of rotomolded polyethylene. In alternate embodiments, other suitable materials may be used. In another embodiment, the containers 100 may be hermetically sealable and shock resistant, and may be suitable for the transport of sensitive electronic equipment from a supplier to an end

3

user. In a further embodiment, the stackable containers **100** are sized and adapted for use in conjunction with the United States military's most common air transport pallet, the 463L, and standard cargo netting.

FIG. **2** is an isometric view of the lid portion **110** of the stackable container **100** of FIG. **1**. In this embodiment, the lid portion **110** includes an upper surface **116** having a plurality of raised rows **114**. Each raised row **114** includes a plurality of raised bosses **112** connected by a plurality of raised ribs **118**. The raised rows **114** improve the structural rigidity of the lid portion **110**, and provide a capability to stack a plurality of the containers **100**, as described more fully below.

FIGS. **3** and **4** are top and side elevational views, respectively, of the lid portion **110** of FIG. **2**. As shown in FIG. **3**, the raised rows **114** are separated by a first distance **D1**, and the centers of the raised bosses **112** are separated by a second distance **D2**. The raised bosses **112** and the raised ribs **118** are sized such that the edges of successive raised bosses **112** are separated by a third distance **D3** along each of the raised rows **114**. The raised rows **114** are adapted such that a plurality of first receiving areas **115** are formed between adjacent raised rows **114**. As further shown in FIG. **3**, an outermost raised row **114** is separated from an outermost edge **117** of the lid portion **110** by a fourth distance **D4**. Also, as shown in FIG. **4**, the raised bosses **112** have a first height **H1**, the raised ribs **118** have a second height **H2**, and the edges of the raised bosses **112** and the raised ribs **118** are oriented at a draft angle α with respect to an axis that is vertical to the upper surface **116**.

In one particular embodiment, each of the raised bosses **112** has an approximately square shape measuring 2.5 inches by 2.5 inches when viewed from above (FIG. **3**), and each of the raised ribs **118** has an approximately rectangular shape when viewed from above. In one particular embodiment, the first height **H1** is 0.75 inches, the second height **H2** is 0.5 inches, and the draft angle α is 10 degrees. Furthermore, in a particular embodiment, each of the raised rows **114** is separated by a first distance **D1** of 4.2 inches, the raised bosses **112** are separated by a second distance **D2** of 4.2 inches, and the fourth distance **D4** is approximately equal of the first distance **D1** (e.g. 2.1 inches). Of course, in alternate embodiments, the raised bosses **112** and the raised ribs **118** may have different shapes and dimensions, and the raised rows **114** may have different distances **D1**, **D2**, **D3**, and **D4**, from the particular embodiment shown in FIGS. **2-4**.

FIG. **5** is an isometric view of the base portion **130** of one of the stackable containers **100** of FIG. **1** in an inverted position. In this embodiment, the base portion **130** includes a lower surface **132** having a plurality of raised cleats **134** formed thereon. A plurality of first ridges **136** extend along a first (or lateral) direction between adjacent cleats **134**, and a plurality of second ridges **138** extend along a second (or longitudinal) direction between adjacent cleats **134**. The raised cleats **134**, the first ridges **136**, and the second ridges **138** cooperatively form a plurality of second receiving areas **135** distributed across the lower surface **132** of the base portion **130**.

FIGS. **6** and **7** are top and side elevational views, respectively, of one of the stacking cleats **134** of the base portion **130** of FIG. **5**. In this embodiment, the stacking cleat **134** has a "cross" or "plus sign" shape (i.e. "+") when viewed from above (FIG. **6**). As shown in FIG. **6**, the stacking cleat **134** has a primary longitudinal dimension **W1**, a primary lateral dimension **W2**, a secondary longitudinal dimension **W3**, a secondary lateral dimension **W4**, and an arm length **W5**. Also, as shown in FIG. **7**, the stacking cleat **134** projects outwardly from the lower surface **132** by a third height **H3**, the lateral ridges **136** project outwardly by a fourth height **H4**, and the

4

longitudinal ridges **138** project outwardly by a fifth height **H5**. Generally, the stacking cleats **134** are distributed over the lower surface **132** of the bottom portion **130** and are adapted to engage with the receiving portions **115** of the lid portion **110** of an adjacent container **100**, as described more fully below.

In one embodiment, as shown in FIG. **6**, the primary longitudinal dimension **W1** is equal to the primary lateral dimension **W2**, and the secondary longitudinal dimension **W3** is equal to the secondary lateral dimension **W4**. More specifically, in one particular embodiment, **W1=W2=2.85** inches, **W3=W4=1.45** inches, and **W5=0.70** inches. Furthermore, in one particular embodiment, the stacking cleats **134** project outwardly from the lower surface **132** by the third height **H3** of approximately 0.75 inches, and the lateral and longitudinal ridges **136**, **138** project outwardly from the lower surface **132** by 0.25 inches (i.e. **H4=H5=0.25** inches).

FIG. **8** is an enlarged side elevational view of an upper stackable container **100A** engaged with a lower stackable container **100B** in accordance with an embodiment of the invention. As shown in FIG. **8**, the base portion **130A** of the upper stackable container **100A** is engaged with the lid portion **110B** of the lower stackable container **100B**. More specifically, the raised cleats **134A** of the base portion **130A** are engaged into the first receiving areas **115B** of the lid portion **110B**, and the raised bosses **112B** of the lid portion **110B** are engaged into the second receiving areas **135A** of the base portion **130A**.

In one particular embodiment, the raised cleats **134A** and the raised bosses **112B** are sized and adapted so that the raised bosses **112B** engage against the lower surface **132A** of the lower portion **130A** of the upper container **100A**, and the raised cleats **134A** engage against the upper surface **116B** of the lid portion **110B** of the lower container **100B**. The contact between the raised bosses **112B** and the lower surface **132A**, and the contact between the raised cleats **134A** and the upper surface **116B**, may advantageously improve the load carrying capabilities of the containers **100A**, **100B**, and may reduce or prevent deformation of the lid and base portions **110B**, **130A** under heavy loads, elevated temperatures, or other operating conditions.

Similarly, in a further embodiment, at least one of the first and second ridges **136A**, **138A** of the lower portion **130A** of the upper container **100A** are sized and adapted to engage with the ribs **118B** of the lid portion **110B** of the lower container **100B**. Again, this contact between the ridges **136A**, **138A**, and the ribs **118B** may improve the load carrying capabilities of the containers **100A**, **100B**, and may reduce or prevent deformation of the lid and base portions **110B**, **130A**.

Embodiments of the present invention may provide significant advantages over prior art stackable containers. Because the raised cleats **134A** of the base portion **130A** are engaged into the first receiving areas **115B** of the lid portion **110B**, and the raised bosses **112B** of the lid portion **110B** are engaged into the second receiving areas **135A** of the base portion **130A**, the upper container **100A** may be securely engaged with the lower container **100B** in the stacked position (FIG. **8**), thereby preventing slipping and sliding of the upper container **100A** relative to the lower container **100B** in the lateral and longitudinal directions.

Furthermore, because the second receiving areas **135A** of the base portion **130A** are formed over the lower surface **132A** by the cooperation of the raised cleats **134A** (and the first and second ridges **136A**, **138A**) rather than by forming indentations or recesses in the lower surface **132A**, an inside surface (not shown) of the base portion **130A** (opposite from the lower surface **130A**) may remain relatively smooth and

even. The resulting relatively smooth inner surface may substantially improve a user's ability to store products in the container 100A, and may advantageously reduce or eliminate the need for specially-crafted foam cushions having relief cuts, indentations, or other means of accommodating the protrusions or irregularities that exist on the inner surfaces of at least some prior art containers. Similarly, because the first receiving areas 115B of the lid portion 110B are formed over the upper surface 116B by the cooperation of the raised bosses 112B (and the raised ribs 118B), an inner surface (not shown) of the lid portion 110B (opposite from the upper surface 116B) also remains relatively smooth and even, which may also substantially improve a user's ability to store products in the container 100B.

Embodiments the present invention may also provide improved interlocking features between successive layers of stackable containers 100. For example, FIG. 9 is a top elevational view of a plurality of stackable containers 100 in a first (or lower) level in accordance with an embodiment of the present invention. As described above with reference to FIG. 3, each of the raised rows 114 is separated by the first distance D1, and the outermost raised row 114 is separated from the outer edge 117 of the lid portion 110 by the fourth distance D4. In one embodiment, the fourth distance D4 may be approximately equal to the first distance D1. Similarly, the last raised boss 112 of each raised row 114 may be separated from the outer edge 117 by a fifth distance D5, and the fifth distance D5 may also be approximately equal to the first distance D1. Therefore, in the embodiment shown in FIG. 9, $D4+D4=2D1$, and $D4+D5=2D1$.

[FIG. 10] FIG. 10A is a partial top elevational view of an upper stackable container 200 engaged with the plurality of lower stackable containers 100 of FIG. 9. FIG. 10B is a close-up view of one of the raised cleats from FIG. 10A. In this embodiment, the upper stackable container 200 spans across a plurality of lower stackable containers 100, with the raised cleats 134 of the base portion 130 engaged in to the first receiving areas 115 on a plurality of lid portions 110 of lower stackable containers 100. Because the fourth distance D4 (the distance from the outermost raised row 114 to the outer edge 117) and the fifth distance D5 (the distance from the last raised boss 112 to the outer edge 117) are both equal to the first distance D1 (the distance between successive raised rows 114), the upper stackable container 200 may span between two lower containers 100 even though the raised rows 114 of the two lower containers 100 are not aligned, but rather, are oriented at 90° angles. Similarly, because the fourth distance D4 is approximately equal to the first distance D1, the upper stackable container 200 may span between two lower containers 100 when the raised rows 114 of the two adjacent lower containers 100 are aligned (running in approximately parallel directions). Thus, embodiments of the present invention may provide enhanced, interlocking, stacking capability between successive levels of stackable containers 100, 200.

FIG. 11 is an enlarged, side elevational view of the handle assembly 150 of the stackable container 100 of FIG. 1 in accordance with yet another embodiment of the invention. In this embodiment, the handle assembly 150 includes a support arm 152 coupled to a handle member 154. The support arm 152 is pivotably coupled to the base portion 130 by a hinge 156 located within a recess 158 in the base portion 130. In operation, the support arm 152 and the handle member 154 are swingably (or pivotably) movable between a deployed (or lifting) position 160, and a stowed (or non-lifting) position 162. As shown in FIG. 11, in the deployed position 160, the

support arm 152 rotates outwardly within the hinge 156 until the support arm 152 engages with a support surface 164 of the base portion 130.

In operation, a user may lift upwardly on the handle member 154 until the support arm 152 engages with the support surface 164 in the deployed position 160. If the user provides further lifting force on the handle member 154, the support arm 152 is prevented from further up for rotation by the support surface 164. After the container 100 is lifted and moved to a desired position, the support arm 152 may be rotated downwardly into the stowed position 162. In the stowed position 162, the support arm 152 and handle member 154 are contained within the recess 158.

Embodiments of the present invention may provide further advantages in comparison with the prior art. For example, in the deployed position 160, because the support arm 152 is prevented from further rotation upwardly by the support surface 164, the user may exert a lifting force on the handle member 154 without causing the handle member 154 to pinch the user's hand against an outer surface of the base portion 130. Similarly, in the stowed position 162, because the support arm 152 and handle member 154 may be disposed within the recess 158 in the base portion 130, the support arm 152 and handle member 154 may be at least partially protected from damage, and may allow a tighter packing between adjacent containers 100.

Alternate embodiments of the present invention may be conceived, and it will be appreciated that the invention is not limited to the particular embodiments described above and shown in FIGS. 1-11. For example, greater or fewer numbers of raised bosses and stacking cleats may be provided on the upper and lower surfaces of the container from that shown in the accompanying figures. Similarly, the raised bosses and stacking cleats may be distributed over the upper and lower surfaces in different patterns and the particular embodiments described above and shown in the company figures. In addition, as described above, the shapes of the raised bosses and stacking cleats may be varied from those particular embodiments described above. For example, in one alternate embodiment, the shapes of the raised bosses 114 and the stacking cleats 134 may be reversed from the embodiments shown in FIGS. 1-11, such that the raised bosses have a "cross" or "plus sign" shape, and the stacking cleats have a "square" shape.

In a further embodiment, as shown in FIG. 12, a first raised member 214 may be approximately circular in shape, and may be fittingly received into an approximately circular receiving area 215 formed by a plurality of second raised members 234, each of the second raised members 234 having one or more contoured edges 237 that cooperatively form the circular receiving area 215. The first raised members 214 may be formed on the upper surface of the lid portion 110, in the second raised members 234 may be formed on the lower surface of the base portion 130, or vice versa. Of course, a variety of other shapes of first and second raised members may be conceived that provide the desired interlocking capability of the base portion of the upper container and the lid portion of the lower container, including, for example, triangular shapes, diamond shapes, polygonal shapes, and even non-polygonal or irregular shapes.

While preferred and alternate embodiments of the invention have been illustrated and described, as noted above, many changes can be made without departing from the spirit and scope of the invention. Accordingly, the scope of the invention is not limited by the disclosure of these preferred and alternate embodiments. Instead, the invention should be determined entirely by reference to the claims that follow.

What is claimed is:

1. A method for stacking containers, comprising: obtaining at least a first container and a second container, each having a lid portion and a base portion, each lid portion having a plurality of first raised members each projecting outwardly from a lid surface and arranged substantially in a first desired direction, each lid portion further including a plurality of first ribs projecting outwardly from the lid surface, each of the plurality of first ribs extending substantially continuously between adjacently located first raised members and oriented along the first desired direction, at least some of the first raised members and first ribs cooperatively forming a plurality of first receiving areas, wherein the plurality of first raised members project outwardly by an amount that is greater than the outward projection of the plurality of first ribs relative to the lid surface, each base portion having a plurality of second raised members each projecting outwardly from a base surface and arranged substantially in a second desired direction, each base portion further including a plurality of second ribs projecting outwardly from the base surface, each of the plurality of second ribs extending substantially continuously between adjacently located second raised members and oriented along the second desired direction, at least some of the second raised members and second ribs cooperatively forming a plurality of second receiving areas, wherein the plurality of second raised members project outwardly by an amount that is greater than the outward projection of the plurality of second ribs relative to the base surface; and stacking the first and second containers relative to each other such that at least some of the raised members of one of the containers are received by corresponding receiving areas of the other container.
2. The method of claim 1, wherein obtaining the first and second containers includes obtaining the lid portions wherein the plurality of first raised members are square-shaped raised members and further includes obtaining the base portions wherein the plurality of second raised members are plus-shaped raised members.
3. The method of claim 1, wherein stacking the first and second containers includes laterally offsetting the lid portion of the one of the containers relative to the base portion of the other container.
4. The method of claim 1, wherein stacking the first and second containers includes contacting the first raised members with the base surface of one of the containers and contacting the second raised members with the lid surface of the other container.
5. A system comprising:
 - a first container assembly including a first lid having a plurality of lid stacking features, each lid stacking feature includes first raised members and a plurality of first ribs projecting outwardly from a surface

- of the lid, each of the plurality of first ribs extending substantially continuously between adjacently located first raised members, each of the first raised members and first ribs projecting outwardly from a lid stacking surface, each first raised member having at least one of a width that exceeds a corresponding width of each first rib and a height that exceeds a corresponding height of each first rib; and
- a second container assembly including a second lid that includes lid stacking features substantially identical to the first lid stacking features and including a plurality of second raised members and a plurality of second ribs, each of the plurality of second ribs extending substantially continuously between adjacently located second raised members;
- wherein the first container assembly further includes a first base having a containment volume substantially coverable by the first lid, the first base having a plurality of base stacking features arranged to engagingly cooperate with the second container assembly, wherein the second lid is positionable beneath the first base.
6. The first container assembly of claim 5, wherein the lid stacking features of the first and second lids in which the first raised members are continuously adjoined to the first ribs includes a stepped transition from the first raised member to the first rib.
7. The first container assembly of claim 5, wherein each base stacking feature includes repetitive sets of base first members continuously adjoined to base second members, each of the base first and base second members projecting outwardly from a base stacking surface, each base first member of the set having a width that exceeds a corresponding width of each base second member of the set.
8. The first container assembly of claim 5, wherein a height of the first raised member exceeds a height of the first rib relative to the lid stacking surface.
9. The first container assembly of claim 5, wherein a linear distance between first raised members of adjacent lid stacking features is less than a corresponding linear distance between first ribs of adjacent lid stacking features.
10. The first container assembly of claim 5, wherein the lid stacking features of at least the first lid are disposed in at least two rows on the lid stacking surface, a first centerline of a first row being separated from a second centerline of a second row by a desired distance.
11. The first container assembly of claim 5, wherein the base stacking features includes a plurality of second raised members projecting from the base stacking surface.
12. The first container assembly of claim 5, wherein the lid stacking feature of the first lid is oriented substantially parallel relative to an edge of the first lid.

* * * * *