

No. 743,556.

PATENTED NOV. 10, 1903.

H. J. PERKINS.
COOLING DEVICE FOR EXPLOSIVE MOTORS.

APPLICATION FILED MAR. 24, 1903.

NO MODEL.

2 SHEETS—SHEET 1.

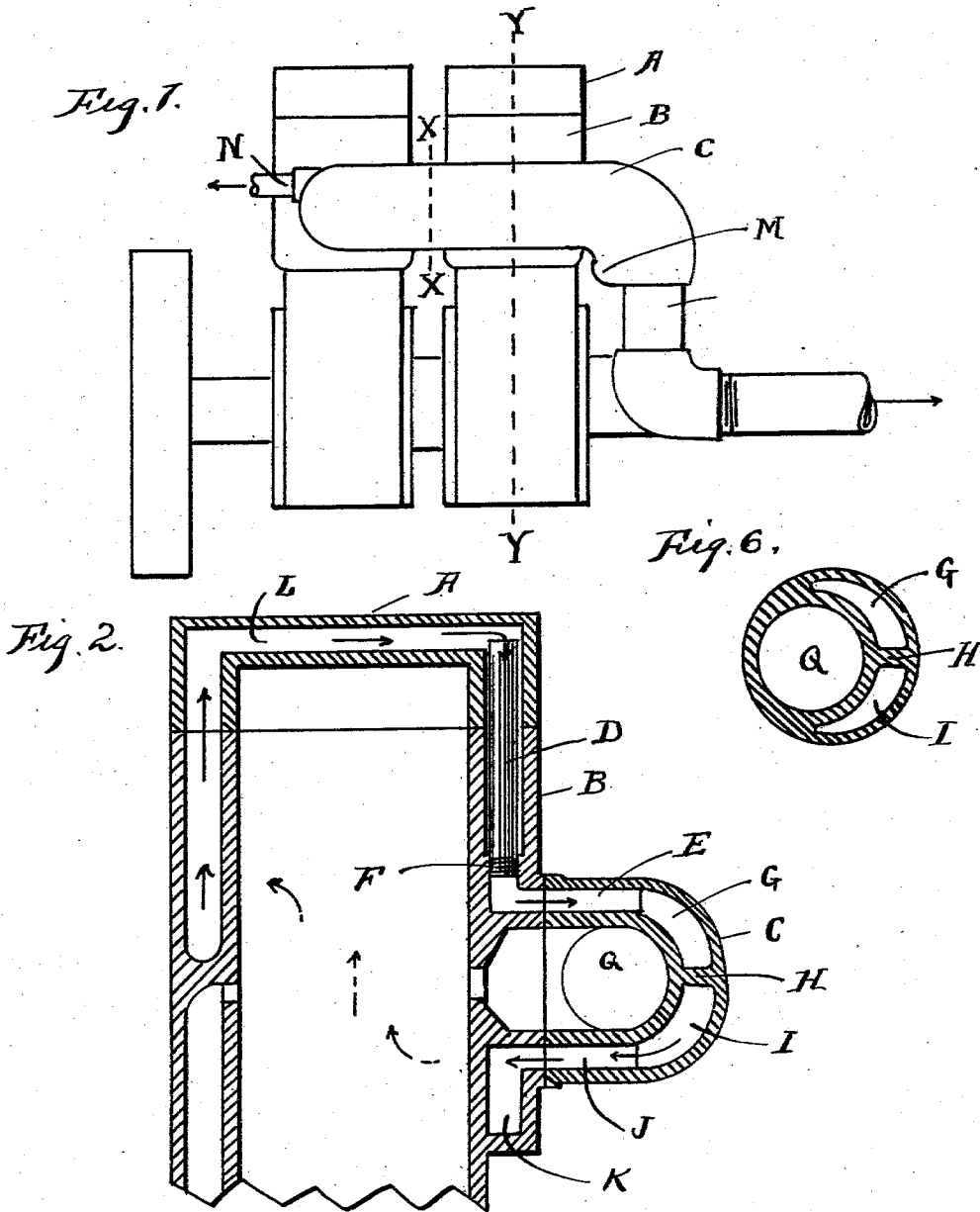

WITNESSES
Mary S. Tooker
Clara Hamilton

BY *his* ATTORNEY

INVENTOR
Harry J. Perkins
Edward J. Jaggard

No. 743,556.

PATENTED NOV. 10, 1903.

H. J. PERKINS.
COOLING DEVICE FOR EXPLOSIVE MOTORS.

APPLICATION FILED MAR. 24, 1903.

NO MODEL.

2 SHEETS—SHEET 2.

Fig. 3.

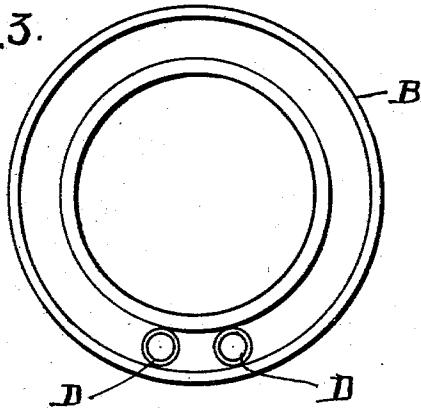

Fig. 5.

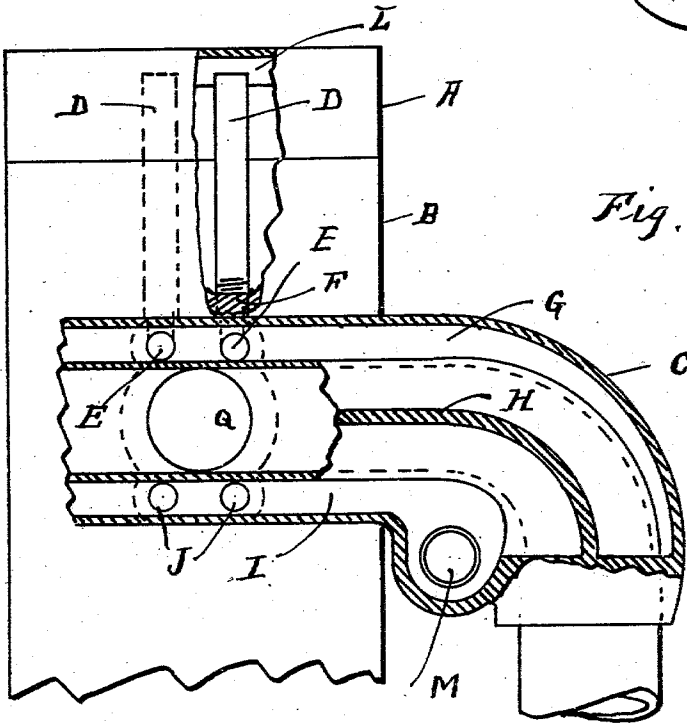
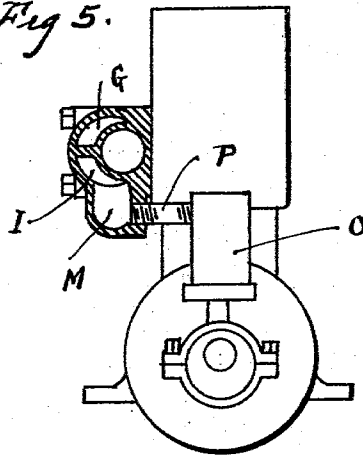

Fig. 4.

WITNESSES
Mary S. Jucker
Clara Hamilton

BY his ATTORNEY

INVENTOR.
Harry J Perkins

Edward Taggart

UNITED STATES PATENT OFFICE.

HARRY J. PERKINS, OF GRAND RAPIDS, MICHIGAN.

COOLING DEVICE FOR EXPLOSIVE-MOTORS.

SPECIFICATION forming part of Letters Patent No. 743,556, dated November 10, 1903.

Application filed March 24, 1903. Serial No. 149,278. (No model.)

To all whom it may concern:

Be it known that I, HARRY J. PERKINS, a citizen of the United States, residing at Grand Rapids, in the county of Kent and State of Michigan, have invented new and useful Improvements in Cooling Devices for Explosive-Engines, of which the following is a specification.

This invention relates to certain new and useful improvements in cooling devices for explosive-engines, and more particularly to the peculiar arrangements of water jackets and passages for cooling the engine, the invention consisting in the combination and arrangement of parts hereinafter described and claimed.

The objects of my invention are, first, to furnish an effective means for cooling the cylinders and pipes by means of water-jackets and water flowing through the same, substantially as hereinafter described; second, to furnish a continuous flow of water in contact with the heated surface of the cylinder to the exhaust-pipes, said water flowing through a series of channels on one side of the exhaust-pipe and returning on the other after having passed through the several water-jackets around the cylinders. These objects I accomplish by means of the mechanism illustrated in the accompanying drawings, in which—

Figure 1 shows a side elevation of an explosive-engine having two cylinders and showing the outer case, which incloses the exhaust-pipe, and a general arrangement of the exhaust-pipe with reference to the cylinders. Fig. 2 shows a sectional view on line *yy* of Fig. 1 looking to the right, said Fig. 2 showing the section enlarged. Fig. 3 is a top plan view of the cylinder with the cylinder-cap removed for the purpose of showing the position of the water-pipes, which extend from the water-chamber in the cap downwardly. Fig. 4 is a horizontal sectional view through the shell which covers the exhaust-pipe and also a portion of one of the cylinders for the purpose of showing the position of the partition which separates the water-passages in the shell which covers the exhaust-pipe and also showing the position of the same with reference to the cylinder. Fig. 5 is an elevation of the water-pump, together with a portion of the water-passages in section, show-

ing how the water passes from the pump into the water-passages. Fig. 6 is a sectional view on the line *xx*.

Similar letters refer to similar parts throughout the several views.

A shows the cylinder-head, such cylinder-head having outer and inner walls and water-passages, as hereinafter described.

B shows the cylinder, which is also composed of outer and inner walls with water-chambers between them.

C shows the outer shell, which covers the exhaust-pipe and which incloses the water-passages hereinafter described.

D and D show two water conduits or pipes, which connect the water-chamber L with the water passage or chamber G.

E and E are water-conduits connecting the water-passages D D with the water-chamber G.

F shows the screw-thread in the cylinder by means of which the tubes D are connected to the cylinder.

G is a water-chamber, from which chamber the water passes out from the exhaust-pipe casing.

I is what I term the "inlet-chamber," for the reason that the water is driven into this chamber by means of the pump, as hereinafter described.

J and J are water-conduits connecting the chamber L to the water-jackets K and L of the cylinder.

K and L are water jackets or chambers surrounding the cylinder.

M is a chamber into which the water is pumped by means of the pump O.

N is an outlet from the water-chamber G.

O is an ordinary water-pump for forcing water through the system of water chambers and passages.

P is a pipe connection between the pump O and the chamber M.

Q represents the exhaust from the engine, the burned gases passing from thence into the exhaust-pipe.

H is a partition or rib which separates the chamber G from the chamber I. This rib or partition in the example shown in the drawings extends practically the length of the case C and so divides the water in this case C that the same is forced into the case and from thence into the cylinder water-cham-

bers, through which it passes and then returns on the other side of the partition, as hereinafter described.

The operation of my invention is as follows:
 5 The water is forced into the system by means of the pump O, which may be a pump of any ordinary construction, and the water from the pump is forced through the pipe P, from whence it passes into the chambers M and I,
 10 as shown in the drawings, on the lower side of the partition H. From thence the water is forced through the pipes or conduits J J into the water-jacket K of the cylinder. Filling this water-jacket, it passes around the
 15 cylinder and upward to the extreme top of the cylinder and fills the water-space around the cylinder and also fills the water-space L in the cylinder-head. From the cylinder-head the water being forced by the pump
 20 passes through the conduits D D and from thence through the conduits E E into the water-chamber G. From the water-chamber G it is forced downward by means of the pump through the outlet N. Thus the
 25 water is compelled, by means of the partition H, to make a circuit on one side of the exhaust-pipe into the cylinder, through the cylinder and cylinder-head, thence downward and along the other side of the exhaust-
 30 pipe through the chambers G, and thence out through the outlet N. By these means the water is kept in constant motion and reaches practically every part of the cylinder and the greater part of the exhaust-pipe, proving
 35 very effective in keeping the cylinder and exhaust-pipe cool.

Having thus described my invention, what I claim to have invented, and desire to secure by Letters Patent, is—

40 1. In combination with a cylinder of an explosive-engine provided with water jackets or spaces, an exhaust-pipe inclosed in a shell or casing, water-spaces between said exhaust-pipe and casing, a longitudinal rib or parti-
 45 tion separating the water on one side of the said partition from the water on the other

side of the said partition, forming two sets of spaces, suitable connection between the said water-spaces and the water-jackets of the cylinder, and suitable means for forcing
 50 the water from the spaces on one side of said partition into the water-jackets in the cylinder and out through the water-spaces on the other side of said partition, so as to keep a
 55 continuous current of water through all the water-jackets in the cylinder and around the exhaust-pipe, substantially as described.

2. In combination with the cylinder of an explosive-engine, of a water-jacket, an exhaust-pipe having an outer casing and a wa-
 60 ter-space between the outer casing and the said pipe, a longitudinal partition separating the water-space into two chambers, and means for circulating the water through the
 65 chamber of the exhaust-pipe and to the water-jacket of the cylinder, through the chamber on one side of the partition to the jacket, and back from the jacket through the chamber on the opposite side of the partition.

3. In combination with a cylinder, an ex-
 70 haust-pipe having an outer casing forming a water-space between the casing and pipe, a longitudinal partition dividing the said water-space into two parts, a cylinder having
 75 water-spaces both in the cylindrical part and in the cap, suitable connection between the water-spaces of the exhaust-pipe casing and the water-spaces in the cylinder, and suitable
 80 means for circulating the water through one of said water-spaces in the exhaust-pipe casing, through the cylinder and cylinder-cap
 85 and back and through the other water-space of said exhaust-pipe casing, substantially as described.

In testimony whereof I have hereunto set
 my hand in presence of two subscribing wit-
 nesses.

HARRY J. PERKINS.

Witnesses:

EDWARD TAGGART,
 MARY S. TOOKER.