

J. C. SWAN.
UNDERREAMER.

(Application filed Jan. 11, 1902.)

(No Model.)

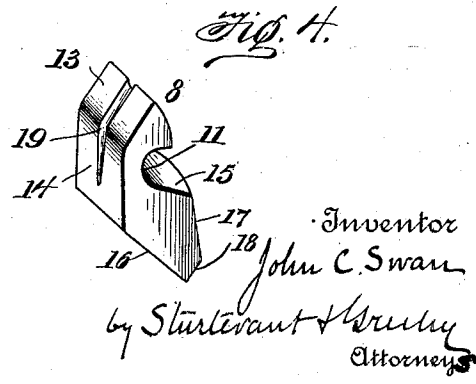
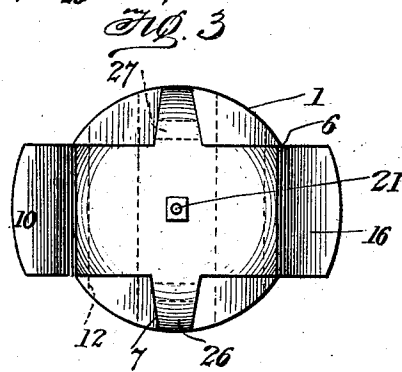
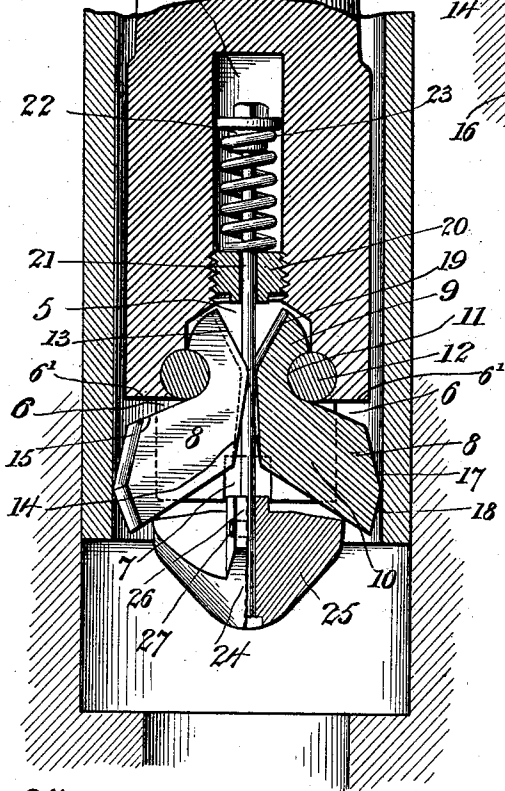
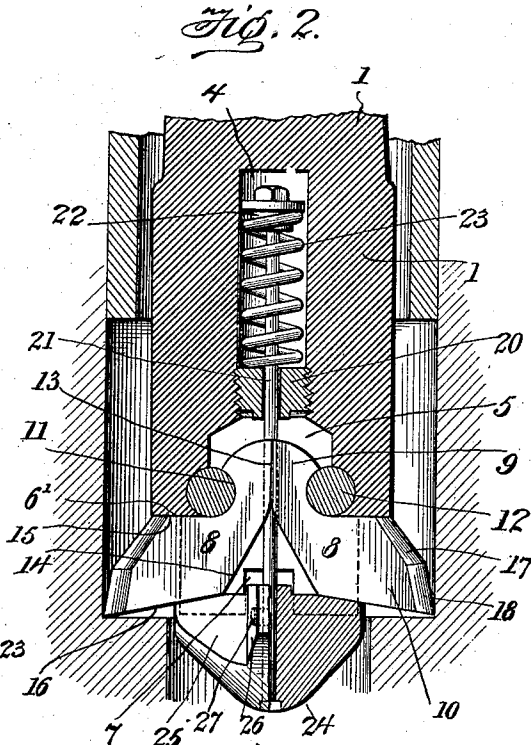
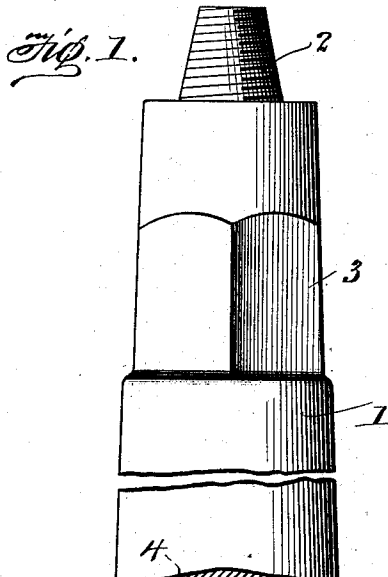

Witnesses
Fenton & Bell
Ernest & West.

Inventor
John C. Swan
 by *Sturtevant & Buckley*
 Attorneys

UNITED STATES PATENT OFFICE.

JOHN C. SWAN, OF MARIETTA, OHIO.

UNDERREAMER.

SPECIFICATION forming part of Letters Patent No. 717,469, dated December 30, 1902.

Application filed January 11, 1902. Serial No. 89,359. (No model.)

To all whom it may concern:

Be it known that I, JOHN C. SWAN, a citizen of the United States, residing at Marietta, in the county of Washington, State of Ohio, have

5 invented certain new and useful Improvements in Underreamers, of which the following is a description, reference being had to the accompanying drawings and to the characters of reference marked thereon.

10 My invention relates to devices for reaming out or enlarging well-holes, and particularly to devices intended for underreaming—that is, reaming out or enlarging the well-hole drilled below a casing in order to permit the

15 casing to be lowered farther down.

In Patent No. 683,352, granted September 24, 1901, I have described an underreamer intended for and capable of operation in hard strata of great thickness, and while the device

20 of this patent is equally useful where the strata are less hard or of comparatively slight thickness a simpler and less expensive device will do effective work under the latter conditions.

25 My present invention has for its object to provide a device which shall be simple and inexpensive in construction and at the same time shall be sufficiently strong to underream effectively where the hard strata are of comparatively slight thickness and not of excessive hardness—as, for instance, the hardest

30 strata met with in the California oil-fields; and my invention consists in the construction and combination of elements hereinafter described.

In the drawings, Figure 1 is a view, partly in elevation and partly in vertical section, showing the invention within a well-casing. Fig. 2 is a similar view showing the invention

40 below the well-casing in position to effect the reaming out or enlarging of the well-hole. Fig. 3 is a bottom view of the invention, and Fig. 4 is a perspective view of one of the reaming-heads.

45 In the drawings, 1 is the reamer-body, having at its upper end the screw-coupling 2 and the squared portion 3. The lower portion of the reamer-body is cylindrical and has formed therein a central bore 4 and a central recess 5, preferably rectangular in cross-section. Slots

50 or recesses 6 are formed in the lower end of the reamer-body, and at right angles there-

with are formed the opposite slots or recesses 7, which are of less depth and less width than the slots or recesses 6. The side walls of the

55 slots or recesses 6 are parallel with the axis of the reamer-body, and the slots or recesses terminate at their upper ends in abutments 6', preferably at right angles with the axis of the reamer-body.

60 Within the slots 6 are located the reaming-heads 8, having shanks 9 extending up into recess 5 and having between their shanks 9 and their body portions 10 bearings 11, which fit and are adapted to turn on pins 12, which

65 extend through the reamer-body at right angles with the slots 6.

The inner faces of the reamer-heads have bearing portions arranged at an angle to each other. The upper portion 13 is so formed

70 that when the reaming-heads are in operative position, as shown in Fig. 2, this portion of one of the reaming-heads will bear against the corresponding portion of the other reaming-head. The lower portions 14 are so formed

75 that when the reaming-heads are in retracted position, as shown in Fig. 1, the portion 14 of one reaming-head will be opposite to the corresponding portion of the other reaming-

80 with. The point of the angle between the portions 13 and 14 is slightly rounded to form a bearing, so that the heads may be readily turned on the pins 12 from the position in which they are shown in Fig. 1 to that in

85 which they are shown in Fig. 2.

The upper face of the body portion 15 of the reaming-head is so formed that when the heads are in operating position, as shown in

90 Fig. 2, this face will bear against the abutment 6'. The lower face 16 of the body portion 10 of the reaming-head is arranged at an angle to the upper face 15, as shown. The outer surface of the reaming-head is formed

95 in two portions 17 and 18 at a slight angle to each other, as shown.

On the inner faces of the reaming-heads is formed a vertical groove 19. At the lower end of the central bore 4, just above the recess 5, is secured in any convenient manner

100 an abutment 20. As shown, this is a nut held in place by screw-threads. Through this abutment or nut extends a rod 21, having a head 22 on its upper end and having between

the head 22 and the abutment or nut 20 a spring 23, by which the rod is normally forced upward. The hole in the nut 20, through which the rod 21 passes, is preferably of such size as to permit a slight sidewise movement of the rod. The portion of the rod below the abutment or nut 20 rests in the grooves 19 of the reaming-heads. On the lower end of this rod is secured a spreader-head 24 of the form shown. This spreader-head has main portions 25 extending beneath the lower surfaces 16 of the reaming-heads, these portions 25 being so shaped that they extend into and completely fill and are guided by the walls of the recess 6. The spreader-head has also at right angles to the portions 25 guide-lugs 26, which fit into and are guided by the walls of the slots or recesses 7. Through these guide-lugs 26 are preferably formed holes 27.

The spring 23, acting upon the rod 21, forces the rod, and with it the spreader-head 24, upward, causing the main portions 25 of the spreader-head to bear upon the inclined lower faces 16 of the reaming-heads, turning them upon the pins 12 and causing them to assume their operative position, as shown in Fig. 2, the upper faces 15 of the reaming-heads resting against the abutments 6' when in this position.

In order to introduce the tool into the well-casing, the spreader-head 24 is drawn downward against the force of the spring 23, so that the reaming-heads are free to be turned by the weight of their main portions into the position shown in Fig. 1. While in this position the tool is introduced into the well-casing and is lowered through it, the reaming-heads during the passage of the tool through the casing bearing against the inner walls. As soon as the reaming-heads pass below the lower end of the well-casing the spring causes the spreader-head 24 to be raised, forcing the reaming-heads outward, as above described. The conical form of the lower face of the head 24 insures the centering of the tool with reference to the hole already drilled which is to be enlarged by the reaming operation, and as the portions 25 and lugs 26 of the spreader-head completely fill the recesses 6 and 7 it closes the end of the reamer-body when the reaming-heads are in operative position against entrance of sediment.

In withdrawing the tool from the well-casing as the reaming-heads in their operative position, as shown in Fig. 2, come in contact with the lower edge of the casing they will be forced downward and inward, the edge of the casing acting upon the inclined upper portion of the outer face of the reaming-heads, the reaming-heads turning on the pins 12 and by their inclined lower faces forcing the spreader-head 24 downward against the force of the spring 23.

The spreader-head 24 and the reaming-heads 8 are positively held against possibility of displacement during use by the walls of

the recesses 6 and 7 in the lower end of the reamer-body.

In order to remove the reaming-heads for the purpose of redressing their cutting edges or for other purposes, it is necessary only to draw the spreader-head 24 downward by means of a rod or cord inserted through the holes 27 in the guide-lugs 26 until the guide-lugs are clear of the recesses 7 and to remove one of the pins 12. This will permit the removal of one of the reaming-heads, and the other reaming-head may then be removed without the necessity of taking out its pin 12, the rod 21 for this purpose being passed over so that the shank of the second reaming-head will pass its pin 12.

In the operation of underreaming the force of the blow as the reaming-heads strike the shoulder of rock which is to be broken away reacts upon the reaming-head in an upward and inward direction. The reaming-head is prevented from upward movement by the contact of its upper face 15 with the abutment 6', and it is prevented from inward movement by the contact of its inner face with the opposing inner face of the other reaming-head, which in turn is prevented from movement by its bearing against its pin 12, as well as by the effect of the blow as it simultaneously with the other reaming-head strikes the shoulder.

Having thus described my invention, what I claim, and desire to secure by Letters Patent, is—

1. In an underreamer, the combination of a reamer-body having open slots formed therein, parallel pivots carried by the reamer-body at right angles to the slots, oppositely-arranged reaming-heads having open bearings adapted to receive the pivots, the reaming-heads being so arranged that when in operative position their inner faces will be in contact, the body portions of the reaming-heads being located in the open slots of the reamer-body, and means for automatically rotating the reaming-heads on their pivots to cause them to assume their operative position; substantially as described.

2. In an underreamer, the combination of a reamer-body having open slots formed therein, parallel pivots carried by the reamer-body at right angles to the slots, oppositely-arranged reaming-heads having open bearings adapted to receive the pivots, the reaming-heads being so arranged that when in operative position their inner faces will be in contact, the reaming-heads each having a vertical groove in its inner face, the body portions of the reaming-heads being located in the open slots of the reamer-body, a vertical rod located in the grooves of the inner faces of the reaming-heads and arranged to be capable of sidewise movement, means for forcing the rod upward and means carried by the lower end of the rod adapted to act upon the reamer-heads to rotate them on their pivots to cause

them to assume their operative position; substantially as described.

3. In an underreamer, the combination of a reamer-body having slots formed therein to receive reaming-heads and having guide-slots at right angles thereto, reaming-heads pivoted within the reamer-body and having their body portions arranged in said slots, a vertically-movable spreader-head located below the reaming-heads and arranged to act against their lower faces, and provided with lugs adapted to enter and be guided by the guide-slots of the reamer-body and means for forcing the spreader-head upward against the reaming-heads to rotate them upon their pivots into operative position; substantially as described.

4. In an underreamer, the combination of a reamer-body having open-ended slots or recesses formed in its lower end to receive reaming-heads, and having open-ended guide slots or recesses also formed in its lower end, reaming-heads pivoted within the reamer-body and having their body portions arranged in the open-ended slots or recesses, a vertically-movable spreader-head located below the reaming-heads and arranged to act against their lower faces, the spreader-head having portions thereof adapted to enter the ends of the open-ended slots or recesses and also having guide-lugs adapted to enter the guide-slots, whereby the end of the reamer-body is closed against the entrance of sediment, and means for forcing the spreader-head upward against the reaming-heads; substantially as described.

5. In an underreamer, the combination of a reamer-body having open-ended slots or recesses formed in its lower end to receive reaming-heads and having open-ended guide slots or recesses also formed in its lower end, reaming-heads pivoted within the reamer-body

and having their body portions arranged in the open-ended slots or recesses, a vertically-movable spreader-head located below the reaming-heads and arranged to act against their lower faces, the spreader-head having its lower face cone-shaped and having portions thereof adapted to enter the ends of the open-ended slots or recesses and also having guide-lugs adapted to enter the guide-slots whereby the end of the reamer-body is closed against the entrance of sediment, and means for forcing the spreader-head upward against the reaming-heads; substantially as described.

6. In an underreamer, the combination of a reamer-body having a central bore adapted to receive a coiled spring, a central recess below the bore, oppositely-arranged open-ended slots or recesses terminating at their upper ends in abutments, pins extending through the reamer-body at right angles to the slots or recesses, oppositely-arranged reaming-heads having open bearings adapted to receive and turn on the pins, having their body portions located in the slots or recesses having their shanks located in the central recess, having their inner faces in contact when in expanded position and having vertical grooves in the inner faces, a vertical rod extending into the central bore and having the coiled spring mounted thereon, the rod being arranged to be capable of sidewise movement and a spreader-head carried by the rod below the reaming-heads; substantially as described.

In testimony whereof I affix my signature in presence of two witnesses.

JOHN C. SWAN.

Witnesses:

FRANK D. BLACKISTONE,
A. P. GREELEY.