

(No Model.)

3 Sheets—Sheet 1.

C. S. HISEY.  
SHELL CARRIER BLOCK.

No. 528,093.

Patented Oct. 23, 1894.

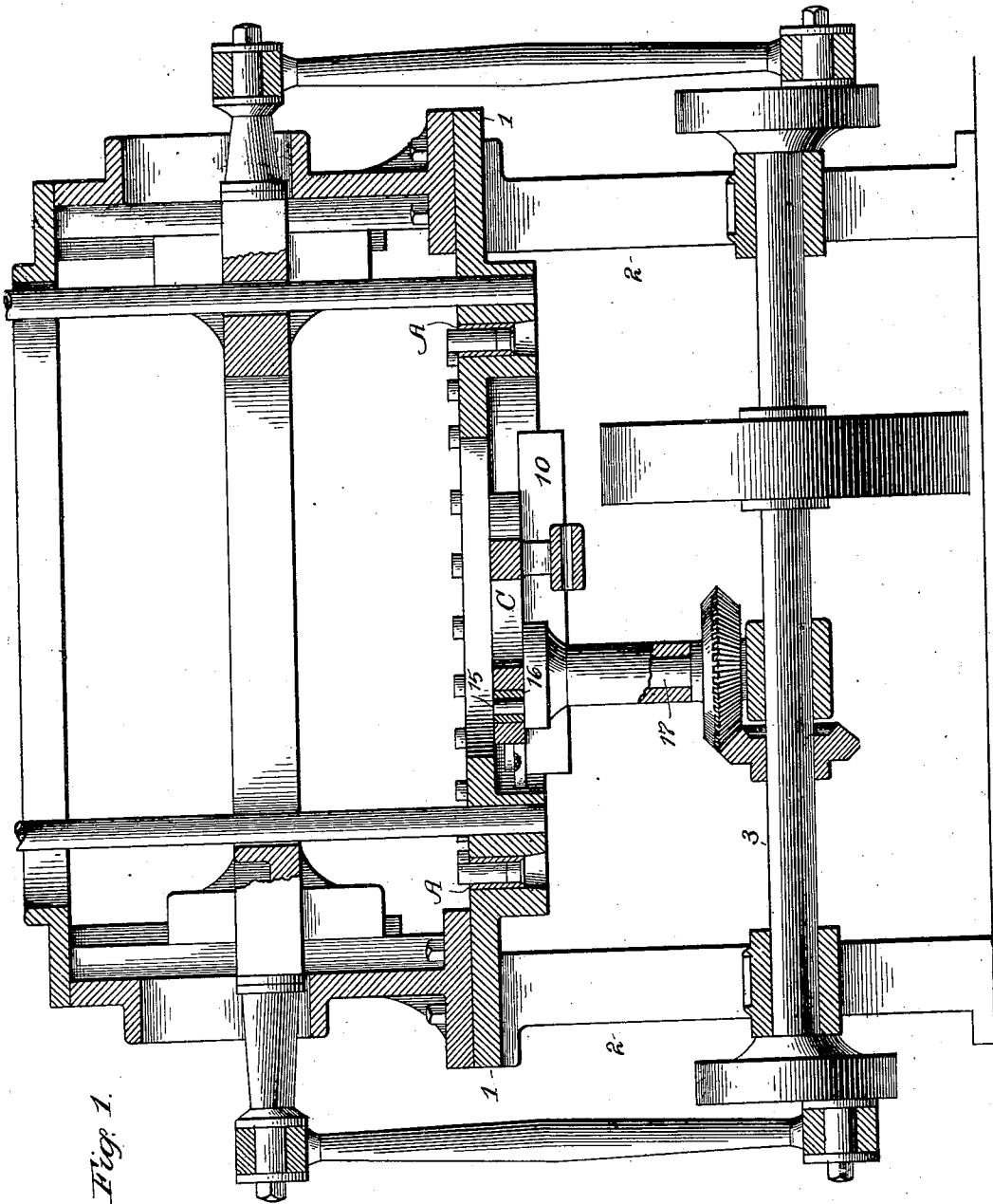

Fig. 1.

Witnesses  
Victor J. Evans.  
L. M. Marble.

Inventor.  
Charles S. Hisey.

by C. M. Marble & Son

Attorneys.

(No Model.)

3 Sheets—Sheet 2.

C. S. HISEY.  
SHELL CARRIER BLOCK.

No. 528,093.

Patented Oct. 23, 1894.

Fig. 2.

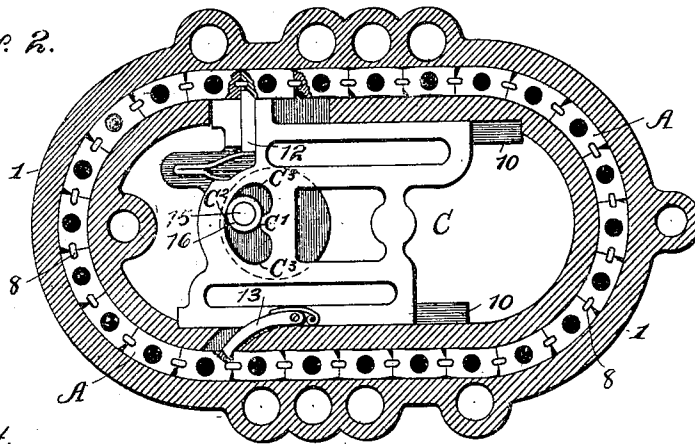

Fig. 4.

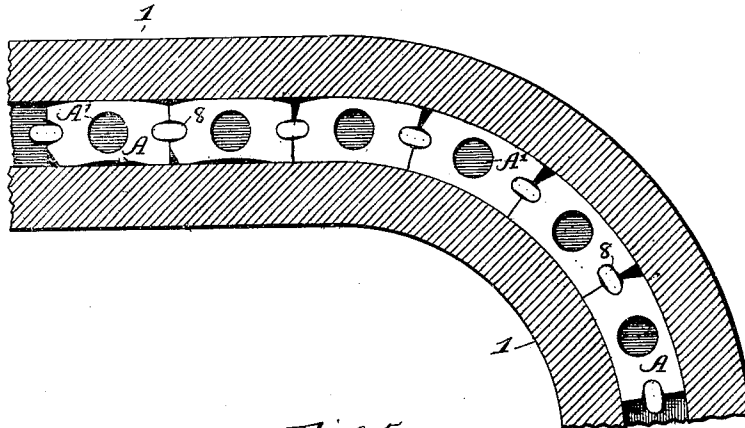
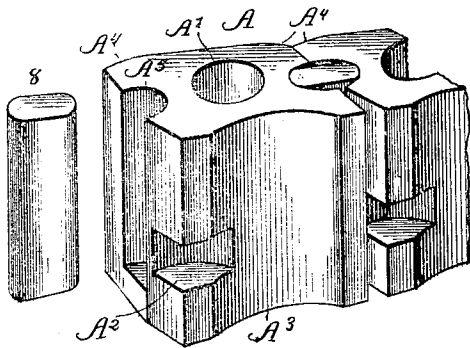

Fig. 5.



Witnesses  
Victor J. Evans.  
L. M. Marble

Inventor  
Charles S. Hisey.  
by E. M. Marble & Son  
Attorneys

(No Model.)

3 Sheets—Sheet 3.

C. S. HISEY.  
SHELL CARRIER BLOCK.

No. 528,093.

Patented Oct. 23, 1894.

Fig. 3.

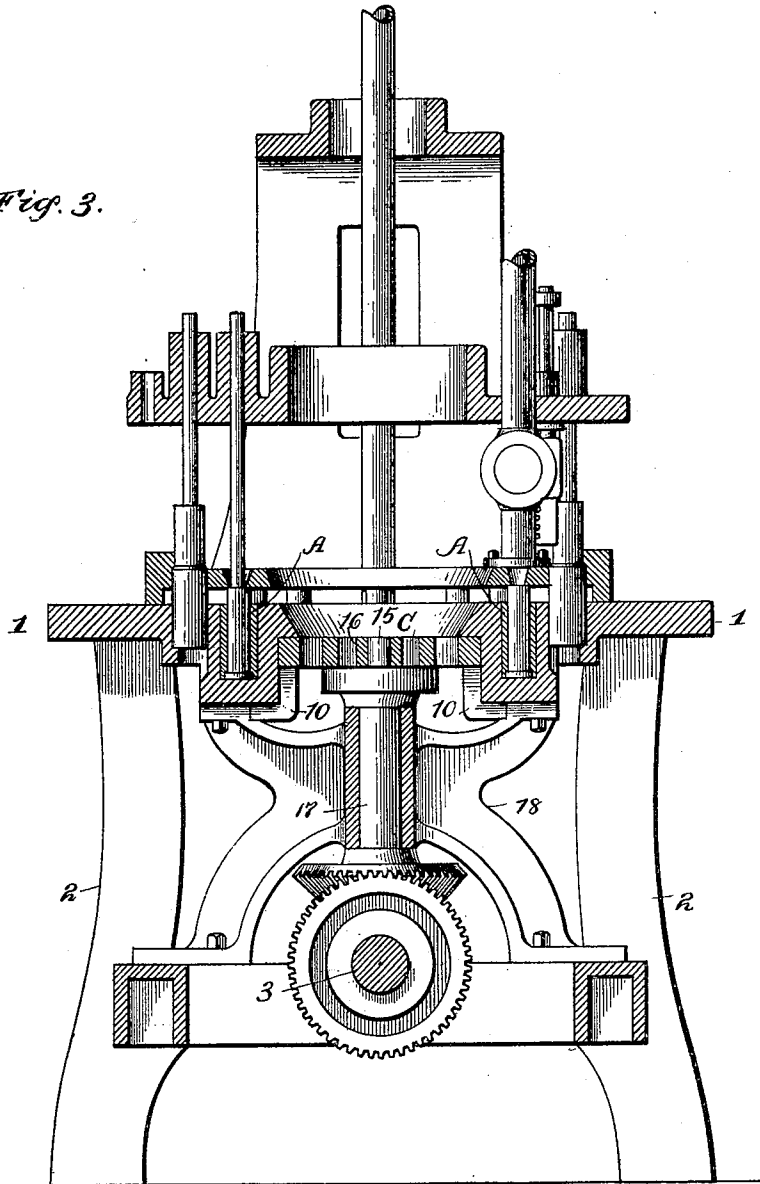

Witnesses  
Victor J. Evans  
L. M. Marble

Inventor  
Charles S. Hisey.  
by E. M. Marble, Sr.  
Attorney

# UNITED STATES PATENT OFFICE.

CHARLES S. HISEY, OF AURORA, INDIANA, ASSIGNOR TO ELLIOTT S. RICE,  
OF CHICAGO, ILLINOIS.

## SHELL-CARRIER BLOCK.

SPECIFICATION forming part of Letters Patent No. 528,093, dated October 23, 1894.

Application filed March 9, 1894. Serial No. 502,981. (No model.)

*To all whom it may concern:*

Be it known that I, CHARLES S. HISEY, a citizen of the United States, residing at Aurora, in the county of Dearborn and State of Indiana, have invented certain new and useful Improvements in Shell-Carrier Blocks; and I do hereby declare the following to be a full, clear, and exact description of the invention, such as will enable others skilled in the art to which it appertains to make and use the same.

My invention relates to improvements in cartridge loading machines, and to the particular class of said machines which is constructed and adapted to charge or fill shot gun cartridges, and it consists in an improved carrier block for the cartridge shells during their travel under the various loading tools of the machine, which will be hereinafter fully described and particularly pointed out in the claims.

In a companion application, filed March 1, 1894, Serial No. 501,935, by myself and Elliott S. Rice, as joint inventors, a machine for loading shot gun cartridges is described, one of the features of which is a shell carrier consisting of a series of independent abutting blocks moving in a groove cut in the machine table, and given an intermittent forward movement by mechanism actuated immediately by the main power shaft of the machine.

The invention embodied in this application relates to the form of the independent blocks which together compose the shell carrier described and claimed in said joint application, and the object of my present invention is to so form these carrier blocks that they will round with ease the curved portions of the groove in the machine table in which they travel, and will mutually assist each other in such travel.

In the companion joint application above referred to, Serial No. 501,935, the shell carrier is composed of a series of independent abutting blocks, each being formed with a shell-receiving cell, and each of the blocks having a projection at one end, and a corresponding recess at the other end. When the blocks are in position to form the carrier the projection formed on one block fits into the recess formed in the next preceding block,

and thus the blocks operatively engage each other, each block assisting the following block in its movement, and at the same time being separately removable. The only objection to this form of block is that by far the greater part of the wear falls upon the projections and recesses formed at the ends of the blocks, and these can not be cut over in this construction, after the blocks have become worn. In the block which forms the subject of this application I obviate this difficulty by forming a recess in each end of each block, and placing the blocks in engagement with each other by means of pins placed in the said recesses between the blocks. When the blocks become worn, the recesses may be slightly enlarged, larger pins inserted, and the blocks still used.

My invention is fully described in the drawings accompanying and forming a part of this application, in which the same reference numerals and letters refer to the same or corresponding parts, and in which—

Figure 1 is a longitudinal section of a cartridge loading machine in which my shell carrier blocks are used, showing particularly the means of actuating the same from the main power shaft. Fig. 2 is a plan section of the machine table, showing particularly the reciprocating carriage by means of which the movement of the shell carrier is produced. Fig. 3 is a transverse section of Fig. 1, illustrating the manner of support of the reciprocating carriage, which intermittently moves the shell carrier. Fig. 4 is an enlarged detail view, showing the carrier blocks in the act of passing around a curved portion of the groove in the machine table. Fig. 5 is a perspective view of a shell carrier block.

Referring to the drawings, 1 represents the machine bed or table. It is rectangular in form, and is supported from the ground by the standards 2. In the upper surface of the table, is cut a deep groove, having straight sides and rounded ends, in which move the shell carrier blocks A, and on both sides of which sets of loading tools may be stationed. This groove is of a depth sufficient to receive the shell carrier blocks A with their upper ends flush with its surface, but the ends of the cartridge shells, when inserted in such blocks, project above its surface. The inte-

rior of the machine table is cut away so as to lighten its weight.

3 is the main power shaft of the machine, and is journaled centrally between the standards of the machine table in cross pieces running between the same.

The shell carrier blocks which move in the groove in the machine table, and which form the subject of this application, are not fastened together, but are entirely independent of each other, and merely abut one another. In each of the blocks is formed a central cell A', adapted to receive and hold a cartridge shell, the end of the shell when in position projecting above the surface of the block, and with a recess A<sup>2</sup> in the front end of its inner face at about the middle portion of its height, into which the pawl may be pressed by means of which the blocks are given an intermittent forward movement.

On the inner sides of the blocks a portion of the metal is centrally cut away, so as to form a curved recess A<sup>3</sup>, and the two corners A<sup>4</sup> of the outer side are each rounded in a corresponding curve. The reason for thus forming the blocks will be apparent when its action is considered in passing around the curved portions of this groove. When passing along the straight portions of this groove, the bearing surfaces of the blocks are the ends of its inner face, and the middle of its outer face; but when rounding a curve, the bearing surfaces change, now becoming the curved recess A<sup>3</sup> and the curved ends A<sup>4</sup>, thus completely reversing the bearing surfaces. To further enable the blocks to pass around the curve, the inner portion of the front face of the block is cut away at an angle, and recesses A<sup>5</sup> are formed at each end of each block, in which pins 8 (see Fig. 2) are placed. This is preferable to that shown in the companion joint application previously referred to, for when the blocks become worn and the recesses cut in the ends of the same get out of shape, the recesses may be slightly enlarged, a larger pin inserted, and the same blocks still used.

The shell carrier blocks A merely abut one another when moving in the groove formed in the machine table, and are entirely independent of one another. Any one of them may be removed at any time in case of breakage, or in case a shell becomes jammed in its cell, and another block inserted in its place.

To enable the movement of the carrier blocks to be fully understood, it has been deemed expedient to describe in connection with the same, the actuating mechanism which imparts an intermittent forward movement to such block-carrier. This mechanism consists of the reciprocating carriage C, and the parts in connection therewith. The carriage C is shown in longitudinal section in Fig. 1, in top plan in Fig. 2, and in transverse section in Fig. 3. Its manner of support is best shown in Fig. 3. As there shown, it slides between the bottom bearing surface formed by

the right angled castings 10, and an upper bearing surface formed by a projecting portion of the machine bed 1, and is so held that its upper surface is level with the top of the side recesses A<sup>2</sup> formed in the carrier blocks. Its general form and operation, however, is best shown in Fig. 2. As there shown, the carriage is arranged to reciprocate a distance equal to the length of a single shell carrier block, so that the spring pressed pawl 12, which slides in a groove cut in one side of its upper surface, will engage with the side recess A<sup>2</sup> formed in each of the shell carrier blocks, a portion of the machine bed being cut away to allow for the reciprocation of the said pawl, and the projecting portion of the carriage C which forms a guide therefor. Starting then from the position shown in Fig. 2, when the blocks are in their forward positions, it will be seen that as the carriage is moved backward, the spring pressed pawl will be forced out of the recess of the block in which it now is, and at the end of such movement will be forced into a corresponding recess in the next following block; and that on its return forward movement, the carriage C will move the shell carrier blocks forward the length of a single block.

To assist the pawl 12 in locking the blocks in their forward positions, a spring pressed pawl 13 is pivoted to the carriage C on the side of such carriage opposite to that where the pawl 12 is situated. This pawl 13, when the carriage is in its forward position, projects through a curved opening formed in the machine bed, and engages with one of the side recesses A<sup>2</sup> in one of the shell carrier blocks A. When the carriage C moves backward, the said pawl is also carried backward, its end moving up the curved recess in the machine table; but when the carriage is in its forward position, this pawl, projecting as it then does into the side recess formed in one of the carrier blocks, securely locks the carrier, and renders impossible any movement of the blocks. If desired, more than one of such locking pawls may be used.

The reciprocating movement of the carriage C is caused by the pin 15 moving in the cam groove C', cut in the front portion of the carriage C. This pin, on which is mounted a roller 16 to minimize the friction, is formed on top of the short shaft 17, which is supported and held in position by the H-shaped casting 18, shown in Fig. 1, and which is provided on its lower end with a miter gear wheel, which meshes with a corresponding miter gear on the main power shaft. Thus at every revolution of the power shaft, the pin 15 describes a complete circle, and the carriage C is caused to move forward and back.

The movement of the pin 15 in the cam slot C' is somewhat peculiar, and is important in the operation of the machine. The slot is formed in two portions, a central portion C<sup>2</sup>,

whose radius is the diameter of the circle in which the crank pin 15 moves, and end portions C<sup>3</sup>, which extend outward at an angle of forty-five degrees to the radius of the circle. 5 The entire width of the slot is equal to or exceeds the diameter of the circle in which the pin 15 moves. The result of thus forming this cam slot is that the reciprocating carriage dwells or remains stationary for a time 10 in its forward position, as while the crank pin 15 moves through the central portion C<sup>2</sup> of said slot, it has no tendency to move the carriage, and the backward movement of the carriage only commences when the crank pin 15 reaches the portion C<sup>3</sup> of the slot. As the pin 15 now continues its revolution, it carries the carriage back with it until a point is reached diametrically opposite the middle portion of its dwell, when the pin rises into the center 20 of the cam slot, forcing the carriage into its extreme backward position, and then commences its forward movement, carrying the carriage C with it, and moving forward the shell carrier the length of one of the blocks 25 composing the same.

The form of the carrier blocks described herein in such as to enable them to move steadily in the straight portion of the groove in which they are placed, and to round with 30 ease any curves in regard to which they have

been constructed. There is no hesitancy or locking in such movement.

The shell carrier actuating mechanism, which is described but not claimed herein, is made the subject of a separate application 35 for Letters Patent, filed by me on March 12, 1894, Serial No. 503,233.

Having thus fully described my invention, what I claim as new, and desire to secure by Letters Patent, is—

1. In a cartridge loading machine, the combination with two or more shell carrier blocks, each of which is formed with a shell receiving cell, and has recesses formed at each end of the block, of suitable operatively engaging 45 means placed in said end recesses between the blocks, substantially as described.

2. In a cartridge loading machine, the combination with two or more shell carrier blocks, each of which is formed with a shell receiving 50 cell, and has recesses formed at each end of the block, of pins 8 placed in said end recesses between the blocks, substantially as described.

In testimony whereof I affix my signature in 55 presence of two witnesses.

CHARLES S. HISEY.

Witnesses:

J. LOWE WHITE,  
JOSEPH D. WOOD.