

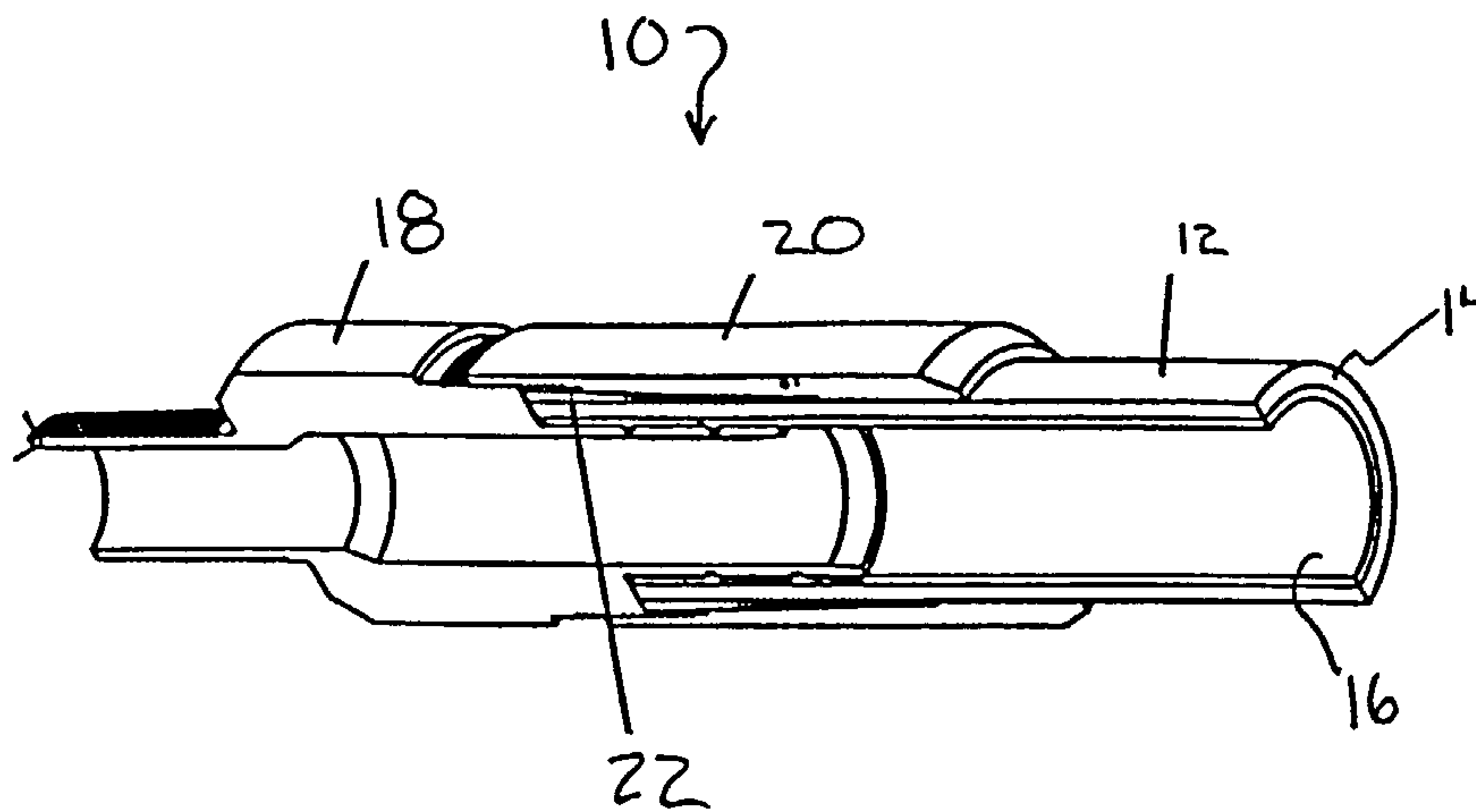

(86) Date de dépôt PCT/PCT Filing Date: 2000/10/04
 (87) Date publication PCT/PCT Publication Date: 2001/04/12
 (85) Entrée phase nationale/National Entry: 2002/03/18
 (86) N° demande PCT/PCT Application No.: US 2000/041073
 (87) N° publication PCT/PCT Publication No.: 2001/025674
 (30) Priorités/Priorities: 1999/10/04 (60/157,614) US;
 2000/10/03 (09/678,577) US

(51) Cl.Int.⁷/Int.Cl.⁷ F16L 47/04
 (71) Demandeur/Applicant:
 FIBERSPAR CORPORATION, US
 (72) Inventeurs/Inventors:
 BROTZELL, ARTHUR D., CA;
 FOWLER, STEWART H., JR., US
 (74) Agent: RICHES, MCKENZIE & HERBERT LLP

(54) Titre : CONNECTEUR D'EXTREMITES POUR TUYAU ENROULE COMPOSITE
 (54) Title: COMPOSITE COILED TUBING END CONNECTOR



(57) **Abrégé/Abstract:**

An improved end connector (10) includes a service end (18), a slip nut (22) disposed about the outer surface of a composite pipe (12) and engageable with the service end, and a slip (20) positioned about the outer surface of the pipe and engaged by the service end and the slip nut. Progressive engagement of the service end relative to the slip nut radially compresses the slip into gripping contact with the pipe. The slip preferably includes pipe-engaging teeth (50) that are sized and shaped to penetrate into an outer layer of the composite pipe. The service end includes an integral seal carrier (32) having a seal (36) thereon, such as an elastomeric O-ring, to seal between the pipe and the seal carrier. The integral seal carrier is positioned in the pipe bore at a location radially opposite the slip to resist deformation of the pipe when the slip is compressed into gripping contact with the pipe.

(12) INTERNATIONAL APPLICATION PUBLISHED UNDER THE PATENT COOPERATION TREATY (PCT)

(19) World Intellectual Property Organization
International Bureau



(43) International Publication Date
12 April 2001 (12.04.2001)

PCT

(10) International Publication Number
WO 01/25674 A1

- (51) International Patent Classification⁷: **F16L 47/04**
- (21) International Application Number: PCT/US00/41073
- (22) International Filing Date: 4 October 2000 (04.10.2000)
- (25) Filing Language: English
- (26) Publication Language: English
- (30) Priority Data:
60/157,614 4 October 1999 (04.10.1999) US
09/678,577 3 October 2000 (03.10.2000) US
- (71) Applicant: **FIBERSPAR SPOOLABLE PRODUCTS, INC.** [US/US]; 28 Patterson Brook Road, West Wareham, MA 02576 (US).
- (72) Inventors: **BROTZELL, Arthur, D.**; 1329 7A Street, Calgary, N.W. T2M 3J7 (CA). **FOWLER, Stewart, H., Jr.**; 6039 Oak Creek Lane, Spring, TX 77379 (US).
- (74) Agents: **LANE, David, A., Jr.** et al.; Foley, Hoag & Eliot, LLP, One Post Office Square, Boston, MA 02109 (US).
- (81) Designated States (*national*): AE, AG, AL, AM, AT, AU, AZ, BA, BB, BG, BR, BY, BZ, CA, CH, CN, CR, CU, CZ, DE, DK, DM, DZ, EE, ES, FI, GB, GD, GE, GH, GM, HR, HU, ID, IL, IN, IS, JP, KE, KG, KP, KR, KZ, LC, LK, LR, LS, LT, LU, LV, MA, MD, MG, MK, MN, MW, MX, MZ, NO, NZ, PL, PT, RO, RU, SD, SE, SG, SI, SK, SL, TJ, TM, TR, TT, TZ, UA, UG, UZ, VN, YU, ZA, ZW.
- (84) Designated States (*regional*): ARIPO patent (GH, GM, KE, LS, MW, MZ, SD, SL, SZ, TZ, UG, ZW), Eurasian patent (AM, AZ, BY, KG, KZ, MD, RU, TJ, TM), European patent (AT, BE, CH, CY, DE, DK, ES, FI, FR, GB, GR, IE, IT, LU, MC, NL, PT, SE), OAPI patent (BF, BJ, CF, CG, CI, CM, GA, GN, GW, ML, MR, NE, SN, TD, TG).
- Published:**
— With international search report.
— Before the expiration of the time limit for amending the claims and to be republished in the event of receipt of amendments.
- For two-letter codes and other abbreviations, refer to the "Guidance Notes on Codes and Abbreviations" appearing at the beginning of each regular issue of the PCT Gazette.*

(54) Title: COMPOSITE COILED TUBING END CONNECTOR

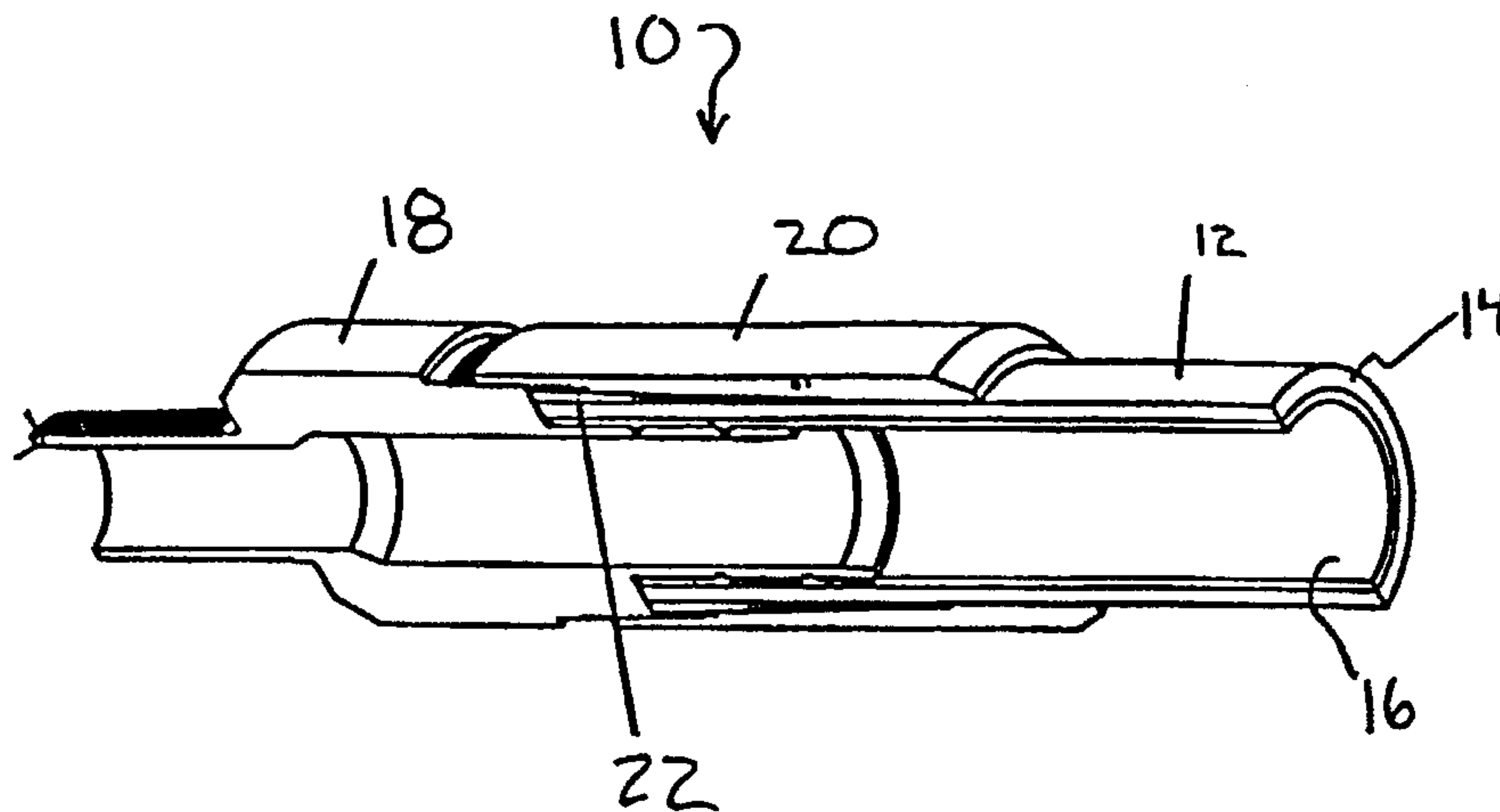

(57) Abstract: An improved end connector (10) includes a service end (18), a slip nut (22) disposed about the outer surface of a composite pipe (12) and engageable with the service end, and a slip (20) positioned about the outer surface of the pipe and engaged by the service end and the slip nut. Progressive engagement of the service end relative to the slip nut radially compresses the slip into gripping contact with the pipe. The slip preferably includes pipe-engaging teeth (50) that are sized and shaped to penetrate into an outer layer of the composite pipe. The service end includes an integral seal carrier (32) having a seal (36) thereon, such as an elastomeric O-ring, to seal between the pipe and the seal carrier. The integral seal carrier is positioned in the pipe bore at a location radially opposite the slip to resist deformation of the pipe when the slip is compressed into gripping contact with the pipe.



WO 01/25674 A1

COMPOSITE COILED TUBING END CONNECTOR

Field of the Invention

This application relates generally to connectors for use with spoolable pipe
5 constructed of composite material and more particularly to a field serviceable connector for
use in such applications.

Background of the Invention

In operations involving spoolable pipe, it is often necessary to make various
10 connections such as to interconnect long sections or to connect tools or other devices into or
at the end of the pipe string. With steel coiled tubing, a variety of well known connecting
techniques are available to handle the severe loads encountered in such operations.
Threaded connections as well as welded connections are easily applied and meet the load
requirements described.

15

Grapple and slip type connectors have also been developed for steel coiled tubing to
provide a low profile and also be field serviceable. These steel tubing connectors are not
applicable to the composite coiled tubing that is now being developed. One such connector
is shown in U.S. Patent 4,936,618 to Sampa et al showing a pair of wedge rings for making
20 a gripping contact with the coiled tubing.

25

The PETRO-TECH Tools Incorporated catalog shows coiled tubing E-Z
Connectors, Product Nos. 9209 to 9211 that are also examples of a slip type steel coiled
tubing connector.

Another connector for reeled thin-walled tubing is shown in U.S. Patent 5,156,206
to Cox and utilizes locking slips for engaging the tubing in an arrangement similar to the
Petro-Tech connector.

30

U.S. Patent 5,184,682 to Delacour et al shows a connector having a compression
ring for engaging a rod for use in well operations, again using a technique similar to a
Petro-Tech connector to seal against the rod.

These commercial coiled tubing connectors will not seal properly as configured to a composite pipe partially because of circumferential deformation of the pipe inwardly when the connector is made up on composite pipe and also because the external surface of a composite tube or pipe is not as regular in OD tolerance which causes sealing problems.

5

U.S. Patent 4,530,379 to Policelli teaches a composite fiber tubing with a structural transition from the fiber to a metallic connector. The fibers may be graphite, carbon, aramid or glass. The Figure 4 embodiment can be employed in a fluid conveyance pipe having bending loads in addition to internal pressure loads and in structural members having bending and axial stiffness requirements.

10

There are many connectors designed for application to elastomeric hoses and tubes such as shown in U.S. Patent 3,685,860 to Schmidt, U.S. Patent 3,907,335 to Burge et al, but sealing to these hoses is substantially different in that the hose body itself serves as a sealing material when pressed against connecting members. A composite pipe is too rigid to function in this way. U.S. Patent 4,032,177 to Anderson shows an end fitting for a non-metallic tube such as a plastic tube and having a compression sleeve and a tubing reinforcing insert but here again the tube itself is deformable to the extent of effecting a seal when compressed by the coupling.

15

20

Another coupling for non-metallic natural gas pipe is shown in U.S. Patent 4,712,813 to Passerell et al and shows a gripping collet for engaging the outer tubular surface of the pipe and a sealing arrangement for holding internal gas pressure within the pipe but no inner seals are on the pipe and seals cannot be changed without disturbing the gripping mechanism.

25

U.S. Patent 5,351,752 to Wood et al shows a bonded connector for coupling composite tubing sections for pumping a well. The composite tubing has threaded fittings made of composite materials which are bonded to the tubing.

30

Summary of the Invention

In accordance with the invention, a connector is provided for use with composite spoolable pipe such as for use in line pipe, production tubing, well logging and workover operations in oil wells. The pipe which is spoolable is comprised of an outer composite structure containing several plies of high strength and stiffness fibers embedded in a resin

material such as epoxy. The fibers are oriented to resist internal and external pressure and provide low bending stiffness. Fibers of high strength and modulus are embedded and bonded into a matrix that keeps the fibers in position, acts as a load transfer medium and protects the fibers from environmental damage. The plastic binder in which the fibers are
5 embedded to form the matrix will have a modulus of elasticity (hereinafter modulus) that exceeds 100,000 psi. Typically, a liner may be employed in the pipe to serve as a structural member, one function of which is pressure containment to resist leakage of internal fluids within the tubing. A wear surface may be employed as an outer layer and may be comprised of a binder containing particles of a tough material.

10

A connector for attaching a composite pipe to a service member according to the teachings of the present invention includes a service end, a slip nut disposed about the outer surface of the composite pipe and engageable with the service end, and a slip positioned about the outer surface of the pipe and engaged by the service end and the slip nut.
15 Progressive engagement of the service end relative to the slip nut radially compresses the slip into gripping contact with the pipe. The service end includes an integral seal carrier having a seal thereon to seal between the pipe bore and the service end. The integral seal carrier is positioned within the bore of the pipe when the end connector is coupled to the composite pipe. Preferably, the integral seal carrier is positioned in the pipe bore at a
20 location radially opposite the slip to resist deformation of the pipe when the slip is compressed into gripping contact with the pipe.

In contrast to the conventional connectors, the connector of the of the present invention does not require a separate seal carrier or a separate load support member.
25 Instead, the service end provides an integral seal carrier to establish a seal between the pipe bore while concomitantly resisting deformation of the pipe from the radially compressive forces applied by the slip. Preferably, the service end including the integral seal carrier is of single piece, unitary construction. In addition, the seal member or seal members carried by the integral seal carrier can also be positioned radially opposite the slip. In this
30 arrangement, the radially compressive force from the slip can operate to enhance the sealing relationship between the seal members and the interior of the pipe

Brief Description of the Drawings

These and other features and advantages of the present invention will be more fully understood by reference to the following detailed description in conjunction with the attached drawings in which like reference numerals refer to like elements through the different views. The drawings illustrate principles of the invention and, although not to
5 scale, show relative dimensions.

Figure 1 is a perspective view in cross-section of the end connector of the present invention, illustrating the end connector coupled to the end of a composite pipe;

10 Figure 2 is a side elevational view in cross-section of the end connector of Figure 1;

Figure 3 is a side elevational view of the service end of the end connector of Figure 1;

15 Figure 4 is a side elevational view in cross-section of the service end of Figure 3;

Figure 5 is a perspective view of the slip nut of the end connector of Figure 1;

20 Figure 6 is a side elevational view in cross-section of the slip nut of Figure 5;

Figure 7 is a perspective view of the slip of the end connector of Figure 1;

Figure 8 is a side elevational view in cross section of the slip of Figure 7;

25 Figure 9 is a detailed elevational view of the teeth of the slip of Figure 7;

Figure 10 is a side elevational view in cross-section of an alternative embodiment of the service end of a connector of the present invention, illustrating an energy conductor embedded in the service end in accordance with the teachings of the present invention; and
30

Figure 11 is a side elevational view in cross-section of an alternative embodiment of the service end of an end connector of the present invention, illustrating raised annular ridges formed on the service end in accordance with the teachings of the present invention.

Detailed Description of the Invention

While this invention is directed generally to providing connectors for composite spoolable pipe, the disclosure is directed to a specific application involving line pipe, coiled tubing service and downhole uses of coiled tubing. Composite coiled tubing offers the potential to exceed the performance limitations of isotropic metals, thereby increasing the service life of the pipe and extending operational parameters. Composite coiled tubing is constructed as a continuous tube fabricated generally from non-metallic materials to provide high body strength and wear resistance. This tubing can be tailored to exhibit unique characteristics which optimally address burst and collapse pressures, pull and compression loads, as well as high strains imposed by bending. This enabling capability expands the performance parameters beyond the physical limitations of steel or alternative isotropic material tubulars. In addition, the fibers and resins used in composite coiled tubing construction make the tube impervious to corrosion and resistant to chemicals used in treatment of oil and gas wells.

High performance composite structures are generally constructed as a buildup of laminant layers with the fibers in each layer oriented in a particular direction or directions. These fibers are normally locked into a preferred orientation by a surrounding matrix material. The matrix material, normally much weaker than the fibers, serves the critical role of transferring load into the fibers. Fibers having a high potential for application in constructing composite pipe include glass, carbon, and aramid. Epoxy or thermoplastic resins are good candidates for the matrix material.

The connector of the present invention can have application to any number of composite tube designs but is arranged to be applied to a pipe having an outer surface made from a composite material that can receive gripping elements which can penetrate into the composite material without destroying the structural integrity of the outer surface. This outer surface can act as a wear surface as the pipe engages the surface equipment utilized in handling such pipe. The composite pipe is suitable for use in wellbores or as line pipe.

Referring to Figures 1 and 2, an end connector 10 according to the present invention provides for the attachment of a composite pipe 12 to a service member (not shown), such as a logging tool, or t-fitting in a pipeline. The composite pipe 12 includes at least one

composite layer 14 of fibers embedded in a polymer matrix and preferably includes a substantially fluid impervious interior liner 16 disposed concentrically within the composite layer 14. Although only one composite layer is illustrated and described herein, one skilled in the art will appreciate that the composite pipe 12 can include multiple composite layers depending on the application and service in which the composite pipe is to be used. The principal components of the end connector 10 include a service end 18, a slip 20, and a slip nut 22.

Referring to Figures 1-4, the service end 18 includes a first coupling surface 26 at a first end 24 thereof for connecting the pipe 12 with a service member and a second coupling surface 28 proximate the midpoint between the first end 24 and the second end 30 of the service end 18. The second coupling surface 28 provides for the connection of the service end 18 with the slip nut 22 and, thus, the assembly of the service end 18 to the pipe 12. The first and second coupling surfaces 26 and 28 can be threaded as illustrated or can be provided with alternative mechanisms for attaching the service end to the service member or the pipe. The service end 18 includes a generally tubular housing bore 32 having an inner diameter that is preferably equal to, or slightly less than, the inner diameter of the composite pipe 12.

The second end 30 of the service end 18 includes an integral seal carrier 32. The integral seal carrier 32 is generally cylindrical in shape and is sized to be received within the bore of the composite pipe 12, as shown in Figures 1 and 2. Preferably, the outer diameter of the integral seal carrier 32 is equal to, or slightly less than, the inner diameter of the composite pipe 12 such that the integral seal carrier 32 can be received within the bore of the composite pipe 12 in a substantially friction-tight fit. Annular grooves 34 are formed in the outer surface of the seal carrier 32 to receive seal members 36, such as elastomeric O-rings, for providing a seal between the integral seal carrier 32 and the composite pipe 12. One skilled in the art will recognize that additional seal members or a single seal member may be used depending on the integrity of the fluid seal desired. A radially extending surface 38 extends radially outward from the outer surface of the seal carrier 32 to form an annular shoulder for engaging the end of the composite pipe 12, as well as an end of the slip 20, when the end connector 10 is coupled to the composite pipe 12.

The service end 18, including the integral seal carrier 32, is preferably of single piece, unitary construction. A significant advantage of the end connector of the present invention is that, unlike conventional end connectors, the end connector 10 of the of the present invention does not require are separate, discrete seal carrier to provide a fluid seal
5 between the end connector and the composite pipe and/or a separate load support member to inhibit deformation of the composite pipe 12 from the slip 20. The service end 18, including the integral seal carrier 32, provides both of these functions.

Referring to Figures 1, 2, and 7-9, the slip 20 is generally cylindrical in shape and is
10 sized to fit about the outer surface of the composite pipe 12. The slip 20 includes a tapered outer surface 40 that tapers from an increased diameter at a first end 44 to a reduced diameter at a second end 46. A longitudinal slot 42 is formed in the slip 20 to permit radially compression of the slip 20. The slip 20 can also be formed in multiple sections to permit radial compression. Pipe-engaging teeth 50 are formed on the inner surface of the
15 slip 20. The teeth 50 are sized and shaped to fully embed into the outer surface of the composite pipe 20. The teeth 20 can be arranged in longitudinally, circumferentially, and/or helically spaced rows. In one preferred embodiment, the teeth are arranged in helically spaced rows oriented at approximately 45° to the longitudinal axis of the composite pipe. Applicants determined that this particular orientation of the teeth provides
20 increased resistant to external torque exerted on the connector.

Each row of teeth preferably includes a generally radially extending surface 52 that intersects with an angled surface 54 to form a sharp point 56, as best illustrated in Figure 9. Preferably, the entire surface of each tooth, i.e. the radially extending surface 52 and the
25 angled surface 54, is engaged with the fibers and the polymer resin forming the composite layer 14 of the pipe 12. In this manner, the teeth 50 permit the transfer of loads into the composite layer 14 of the composite pipe 12.

Alternatively, the slip 20 can be provided with teeth sized, shaped, and arranged in a
30 manner analogous to the teeth of the slip of the end connector described in commonly-assigned U.S. Patent Application Serial No. 08/271,135, filed September 26, 1996, incorporated herein by reference.

Continuing to refer to Figures 1 and 2, and referring specifically to Figures 5 and 6, the slip nut 22 is generally cylindrical in shape and is provided with a threaded coupling surface 60 formed on the inner surface thereof. The inner bore 64 of the slip nut 22 includes a centrally located tapered surface 62 for engaging the outer surface 40 of the slip 5 20 when the end connector 10 is coupled to the pipe 12. The inner bore 64 is sized to permit the slip nut 22 to be positioned about the outer surface of the composite pipe 12.

Each of the components of the end connector 10, namely the service end 18, the slip 20, and the slip nut 22 can be constructed from either metallic materials, composite 10 materials, thermoplastics, elastomers, or combinations thereof. In one preferred embodiment, the components of the end connector 10, in particular the service end 18, can be constructed of a metallic material coated with a corrosion resistant material, such as, for example, epoxy.

15 When assembled, the slip nut 22 is slid over the outer surface of the composite pipe 12. The slip 20 is positioned about the composite pipe 12 and within a recess formed between the outer surface of the pipe and tapered surface 62 of the slip nut 22. The integral seal carrier 32 of the service end 18 is positioned within the bore of the composite pipe 12 such that the shoulder formed by radially extending surface 38 abuts the end of the 20 composite pipe 12. The slip nut 22 is coupled to the service end 18 by threaded engagement of the second coupling surface 28 and the threaded coupling surface 60 of the slip nut. During coupling, the service end 18 and the slip nut 22 move axially towards one another and the tapered surface 62 of the slip nut 22 engages the tapered outer surface 40 of the slip 20. Once the first end 44 of the slip 20 abuts the radially extending surface 38 of 25 the service end 18, as best illustrated in Figure 2, the engaging action of the tapered surface 62 on the slip 20 acts to radially compress the teeth 50 of the slip 20 into engagement with the outer surface of the composite pipe 12.

Preferably, the service end 18 is positioned such that the annular groves 34 of the 30 integral seal carrier 32, and the seal members 36, are positioned radially opposite the slip 20 when the end connector 10 is coupled to the composite pipe 12, as illustrated in Figure 1 and 2. By positioning the integral seal carrier 32 in this manner, the integral seal carrier 32 can establish a fluid seal with the bore of the composite pipe 12 while concomitantly resisting deformation of the pipe from the radially compressive forces applied by the slip

20. Thus, in contrast to conventional connector embodiments, the end connector 10 of the present invention does not require a separate seal carrier to provide a fluid seal or a separate load support member to inhibit deformation of the composite pipe 12. The integral seal carrier 32 of the service end 18 provides these functions. Additionally, in this arrangement, 5 the radially compressive force from the slip 20 can operate to increase the sealing relationship between the seal members 36 and the bore of the composite pipe 12.

The end connector of the present invention can also include one or more energy conductors to permit connection of energy conductors mounted within the composite pipe 10 to the energy conductors of a service member or the energy conductors of another composite pipe. For example, Figure 10 illustrates a service end 118 including an energy conductor 170 embedded in the service end 118. The energy conductor 170 can be an electric medium, such as a copper wire, an optical medium, such as an optical fiber, a hydraulic medium, a pneumatic medium or any material or substance capable of being 15 modulated with data signals or power. The energy conductor 170 provides structure to connect the energy conductors of the composite pipe to the energy conductors of a service member. Composite pipes including energy conductors are described in commonly assigned U.S. Patent No. 5,921,285 and commonly assigned US. Patent No. 6,004,639, each of which are incorporated herein by reference.

20

An alternative embodiment of the service end 218 is illustrated in Figure 11, in which the annular grooves and the seal members of the integral seal carrier 232 are replaced with raised, barb-like, ridges 280. The ridges 280 can be generally triangular in cross-section to form a sharpened point for embedding into the inner layer, such as the interior 25 liner, of the composite pipe. The ridges 280 can also have other cross-sectional shapes sufficient for the ridges to embed in the inner layer of the composite pipe. The ridges 280 can alternatively be spiral or circular oriented threads. The raised ridges 280 eliminate the need for separate seal members, which can wear during use resulting in fluid leakage. Also, because grooves need not be formed in the seal carrier, the thickness of the wall 290 of the 30 integral seal carrier 232, indicated by arrow t in Figure 11, can be reduced. This reduction in thickness allows the inner diameter of the integral seal carrier 232 to more closely match the inner diameter of the composite pipe thereby minimizing flow disruptions and turbulence of the fluid within the pipe at the interface of the seal carrier and the composite pipe.

It should be understood that the component parts of the embodiments of Figures 10 and 11, respectively, are similar to those previously described herein, and accordingly the same reference numerals are used to designate similar parts although the numerals are incrementally increased by 100 to differentiate the embodiments described herein.

5

Commonly assigned U.S. Patent Application Serial No. 09/410,605, filed October 1, 1999, and entitled Composite Coiled Tubing End Connector and Pipe-To-Pipe Connector, is incorporated herein by reference.

10

While particular embodiments of the present invention have been shown and described, it is apparent that changes and modifications may be made without departing from this invention in its broader aspects, and therefore, the aim in the appended claims is to cover all such changes and modifications as fall within the true spirit and scope of this invention.

15

International Application No. PCT/US00/41073

We claim:

1. A connector for attaching a composite pipe to a service member, the composite pipe including at least one composite layer of fibers embedded in a polymer matrix, the
5 connector comprising
- a service end having a first coupling surface for connecting the pipe with the service member, a second coupling surface for assembling the service end with the pipe, and an integral seal carrier for carrying a seal thereon to seal between the pipe bore and the service end, the integral seal carrier being positionable within the bore of the pipe when the end
10 connector is coupled to the composite pipe,
- a slip nut disposed about the outer surface of the pipe and engageable with the second coupling surface on the service end,
- an energy conductor coupled to the service end for connection with an energy conductor within the composite pipe, and
15 a slip positioned about the outer surface of the pipe and engaged by the service end and the slip nut to compress the slip into contact with the pipe upon progressive engagement of the service end with the slip nut, the slip having teeth formed on the inner surface thereof for engaging the outer surface of the pipe.
- 20 2. The connector of claim 1, wherein the slip includes a longitudinal slot to facilitate embedding of the teeth of the slip into the pipe.
3. The connector of claim 1, wherein the slip comprises multiple components to facilitate embedding of the teeth of the slip into the pipe.
25
4. The connector of claim 1, wherein a recess is formed in the slip nut, the recess being configured to matingly receive the slip and to engage and move the slip into gripping contact with the pipe when the slip nut is engaged with the service end.
- 30 5. The connector of claim 4, wherein the slip nut includes a conically tapered surface defining the recess in the slip nut, the conically tapered surface engaging the slip to compress the slip into gripping contact with the pipe.

International Application No. PCT/US00/41073

6. The connector of claim 1, wherein the teeth of the slip are arranged in longitudinally spaced rows.
7. The connector of claim 1, wherein the teeth of the slip are arranged in helical rows oriented at approximately 45° to the longitudinal axis of the composite pipe.
8. The connector of claim 1, wherein the teeth are arranged in longitudinally and circumferentially spaced rows.
9. The connector of claim 1, wherein the teeth have a substantially radially extending surface.
10. The connector of claim 1, wherein the service end is of unitary construction.
11. The connector of claim 1, wherein the service end is of metallic materials.
12. The connector of claim 1, wherein the service end is of thermoplastic materials.
13. The connector of claim 1, wherein the service end is of composite materials.
14. The connector of claim 1, wherein the service end is of metallic materials coated with a corrosion resistant material.
15. The connector of claim 1, wherein the integral seal carrier is positioned in the pipe bore at a location radially opposite the slip to resist deformation of the pipe when the slip is compressed into gripping contact with the pipe.
16. The connector of claim 1, wherein the teeth are sized and shaped to penetrate into an outer layer of the pipe.
17. The connector of claim 1, wherein the integral seal carrier includes at least one annular groove formed thereon for carrying an annular seal.

International Application No. PCT/US00/41073

18. The connector of claim 17, further comprising an annular seal positioned within the annular groove.
19. The connector of claim 17, wherein the annular groove is positioned at a location
5 radially opposite the slip.
20. A connector for attaching a composite pipe to a service member, the composite pipe including at least one composite layer of fibers embedded in a polymer matrix, the connector comprising
10 a service end having a first coupling surface for connecting the pipe with the service member, a second coupling surface for assembling the service end with the pipe, and an integral seal carrier positionable within the bore of the pipe when the end connector is coupled to the composite pipe, the integral seal carrier including a raised ridge thereon for engaging an inner layer of the composite pipe to establish a fluid seal between the integral
15 seal carrier and the pipe when the end connector is coupled to the pipe,
a slip nut disposed about the outer surface of the pipe and engageable with the second coupling surface on the service end,
an energy conductor coupled to the service end for connection with an energy conductor within the composite pipe, and
20 a slip positioned about the outer surface of the pipe and engaged by the service end and the slip nut to compress the slip into contact with the pipe upon progressive engagement of the service end with the slip nut, the slip having teeth formed on the inner surface thereof for engaging the outer surface of the pipe.
21. The connector of claim 20, wherein the raised ridge is sized and shaped to embed
25 into the inner layer of the composite pipe.
22. The connector of claim 20, wherein the raised ridge has a substantially triangular cross-section.
30
23. The connector of claim 22, wherein the raised ridge has a sharpened point for embedding into the inner layer of the pipe.

International Application No. PCT/US00/41073

24. The connector of claim 20, wherein the raised ridge is a spiral thread formed on the integral seal carrier.

25. The connector of claim 24, further comprising a plurality of spaced-apart raised
5 ridges on the integral seal carrier.

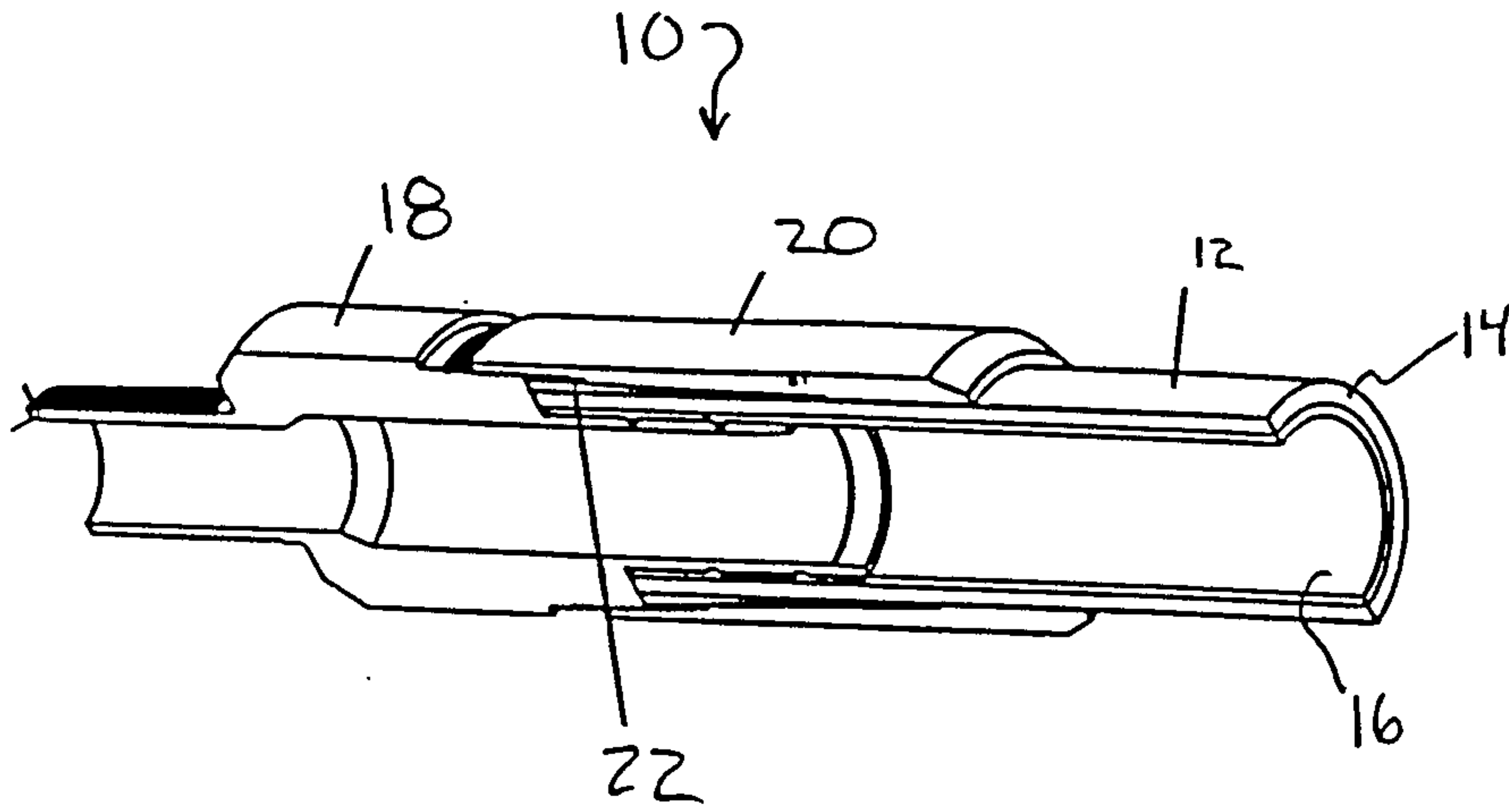

Figure 1

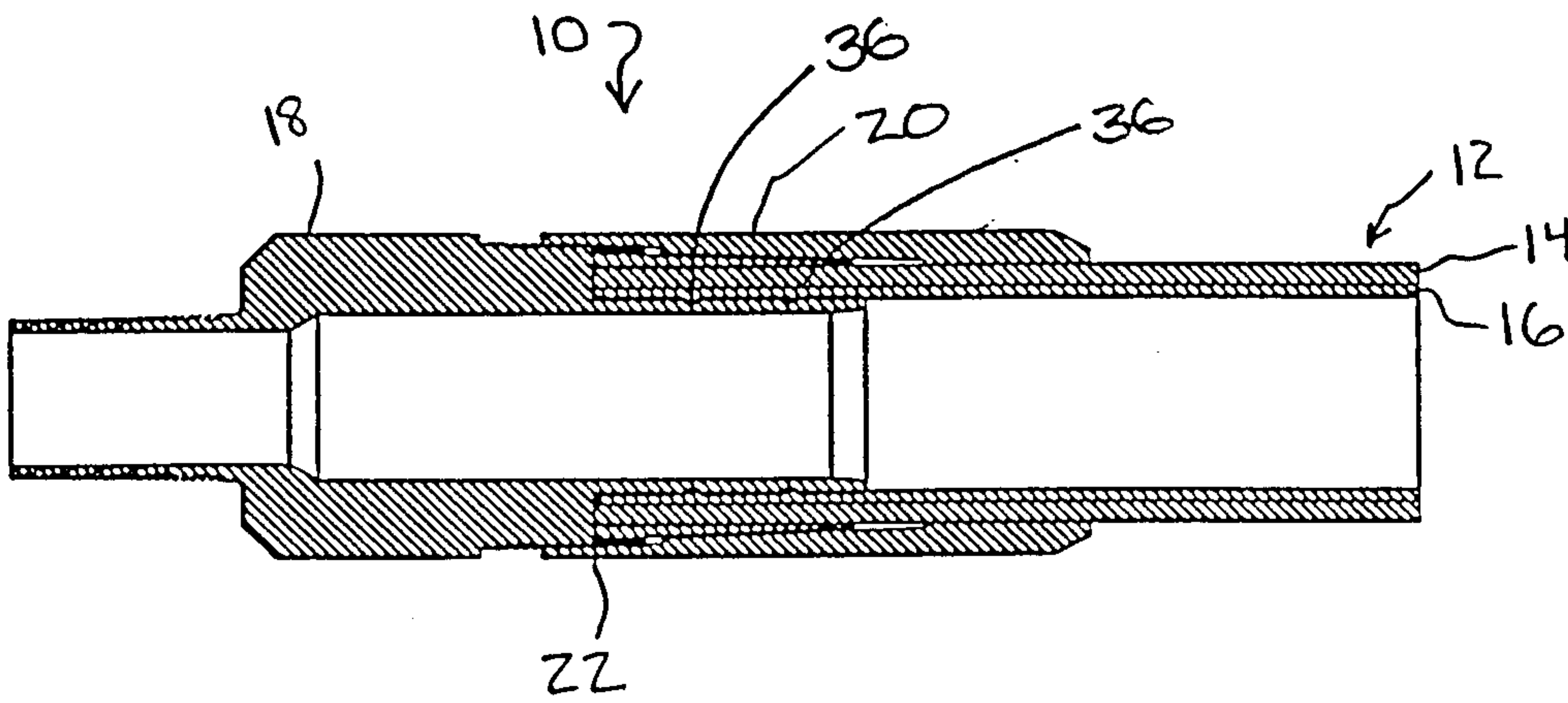
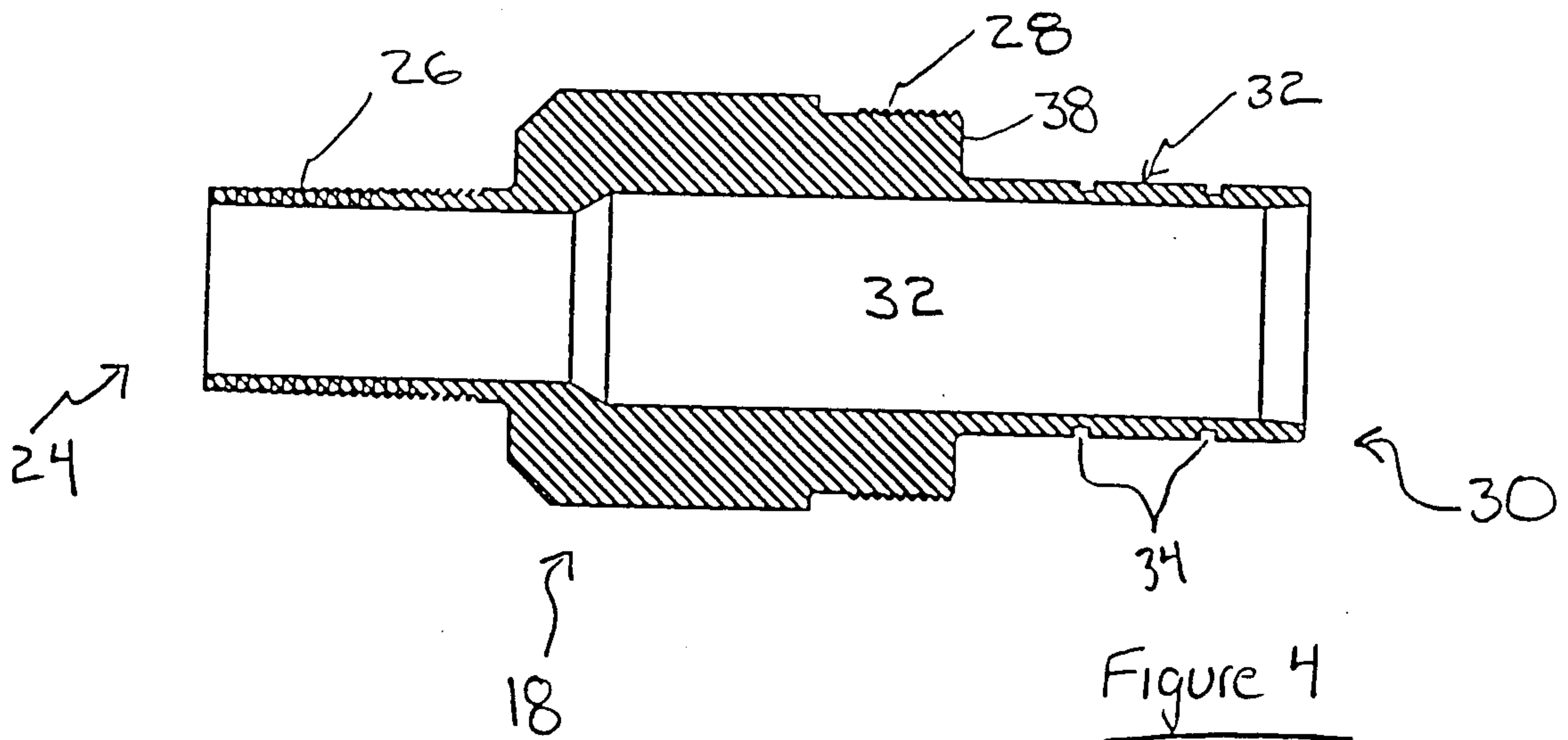
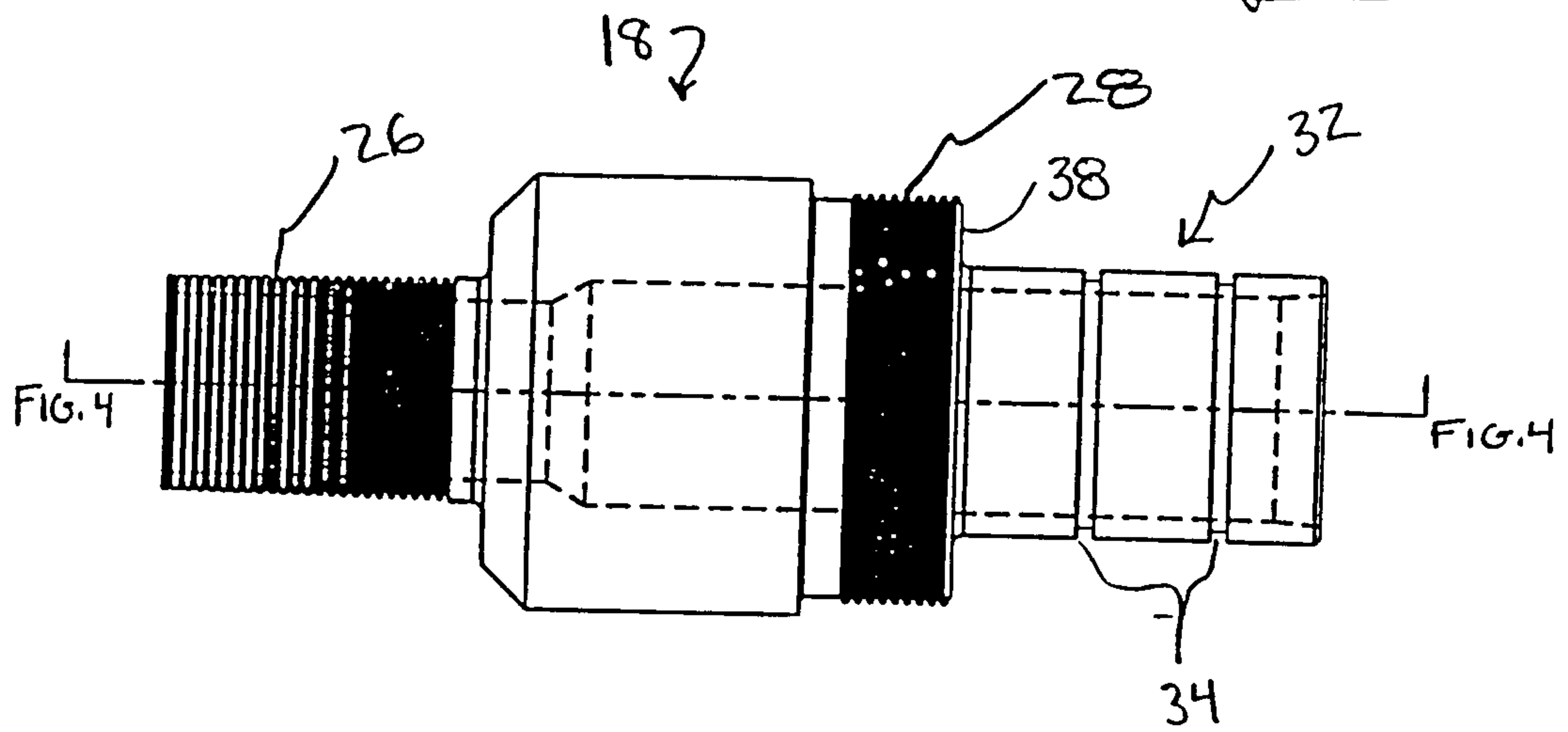

FIGURE 2

Figure 3



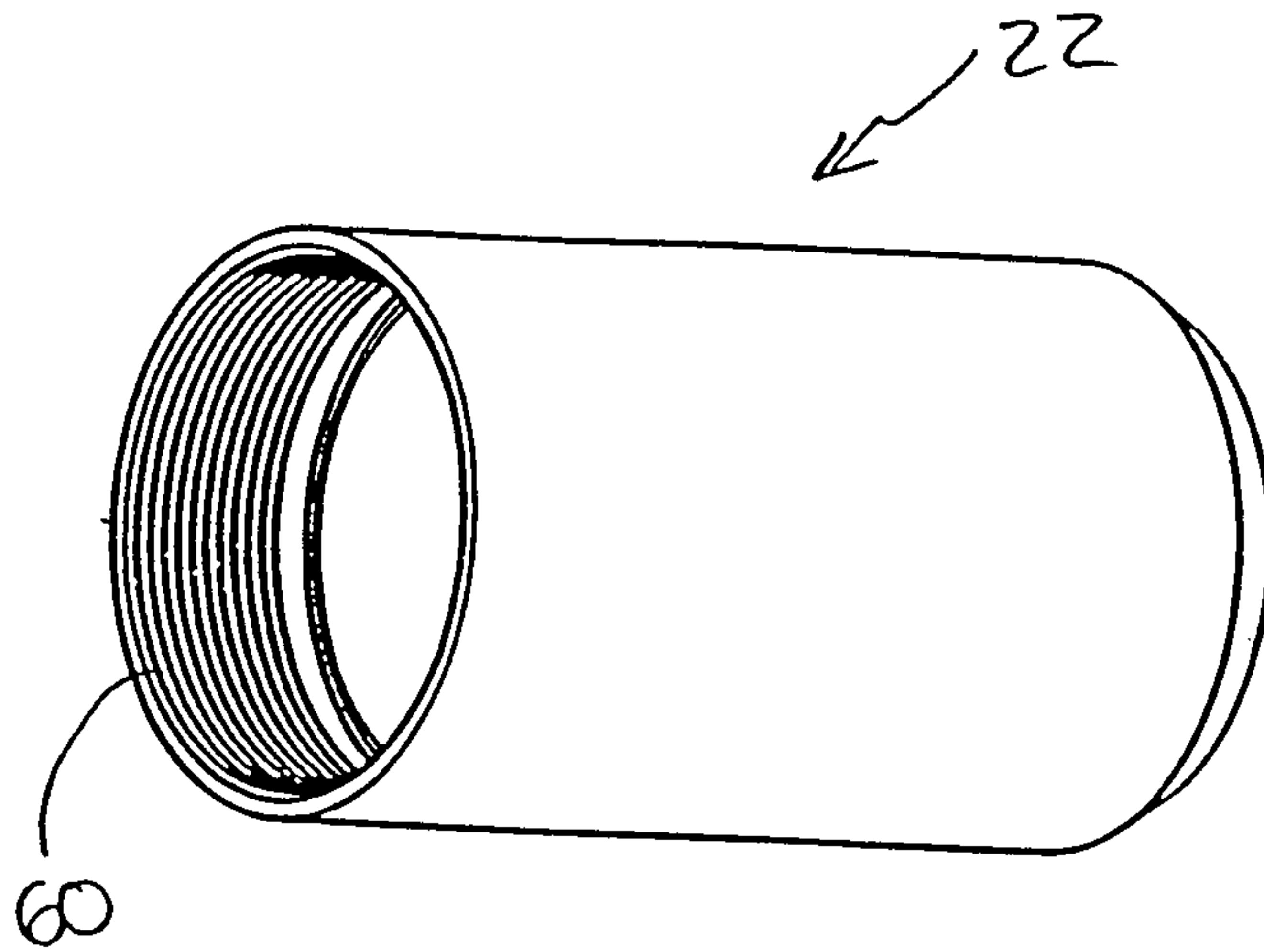

FIGURE 5

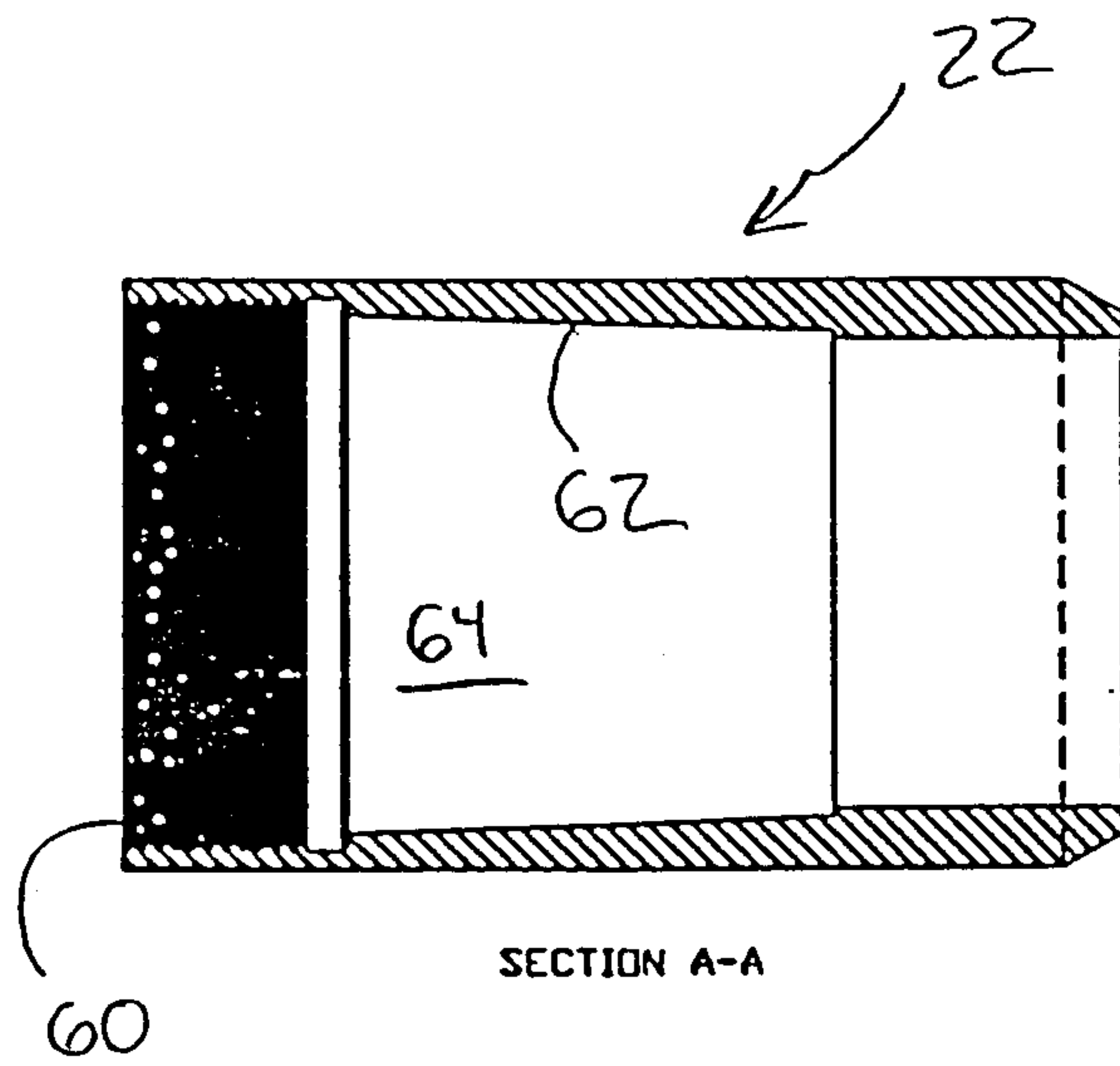

FIGURE 6

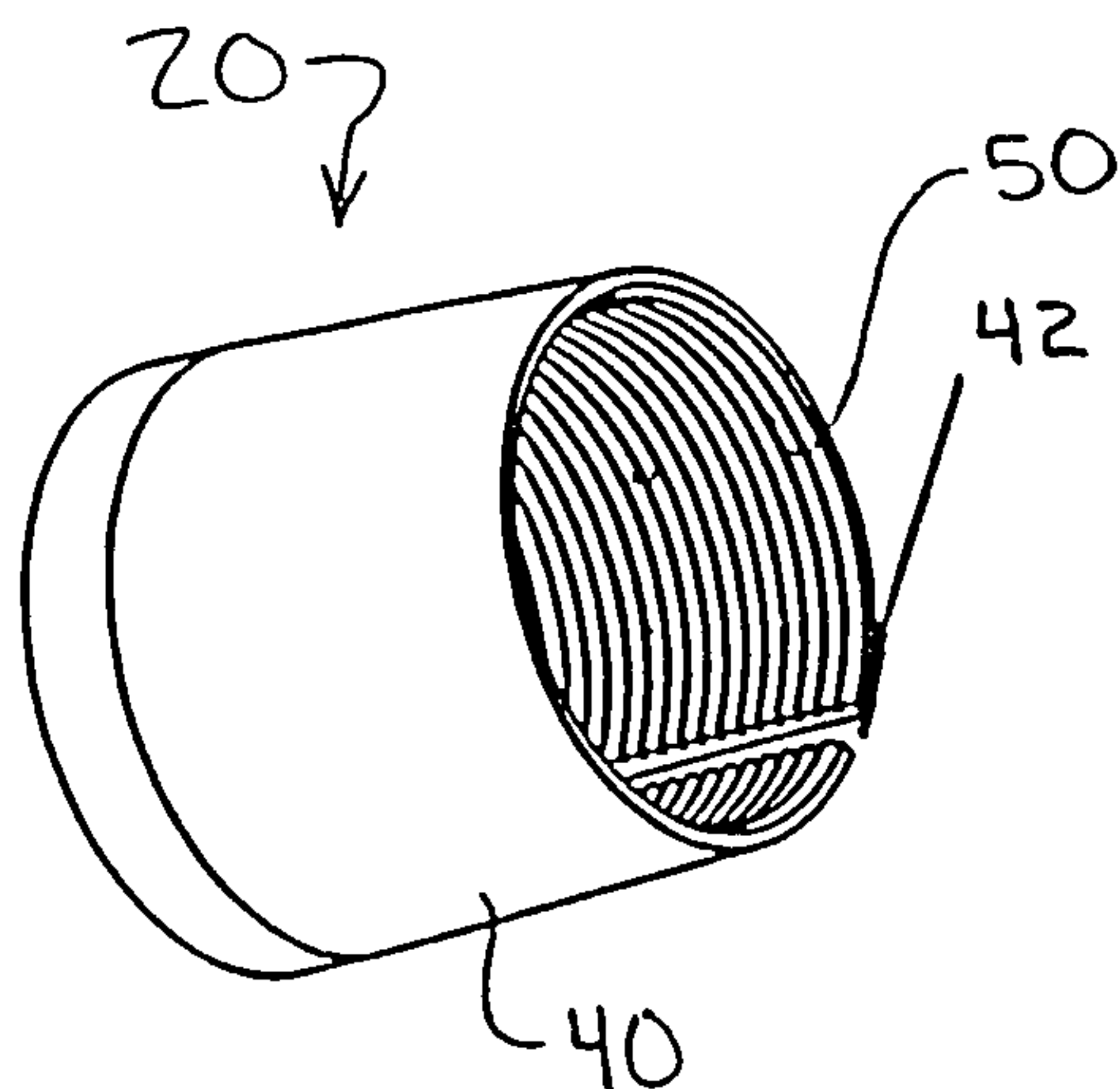

FIGURE 7

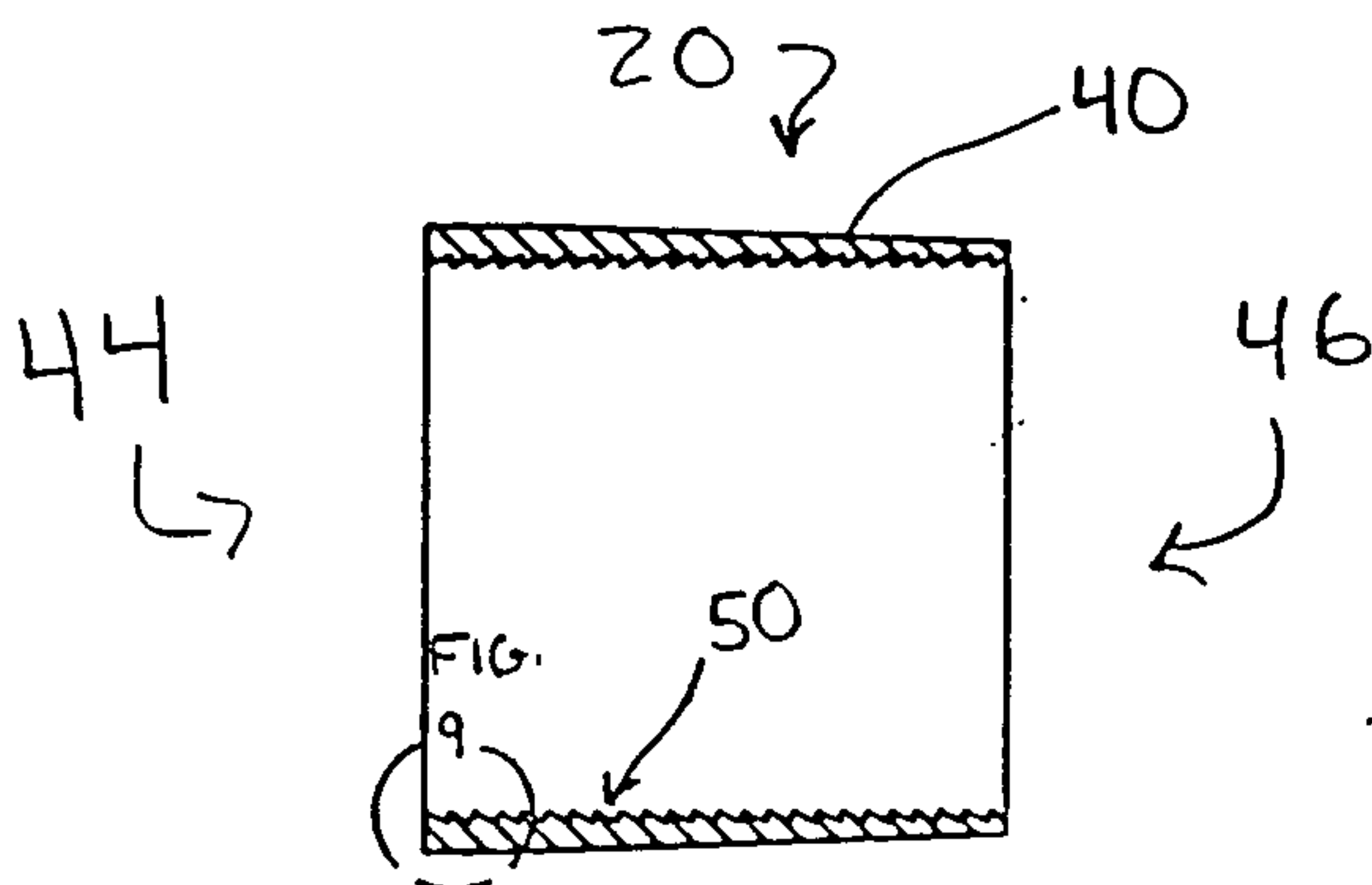

FIGURE 8

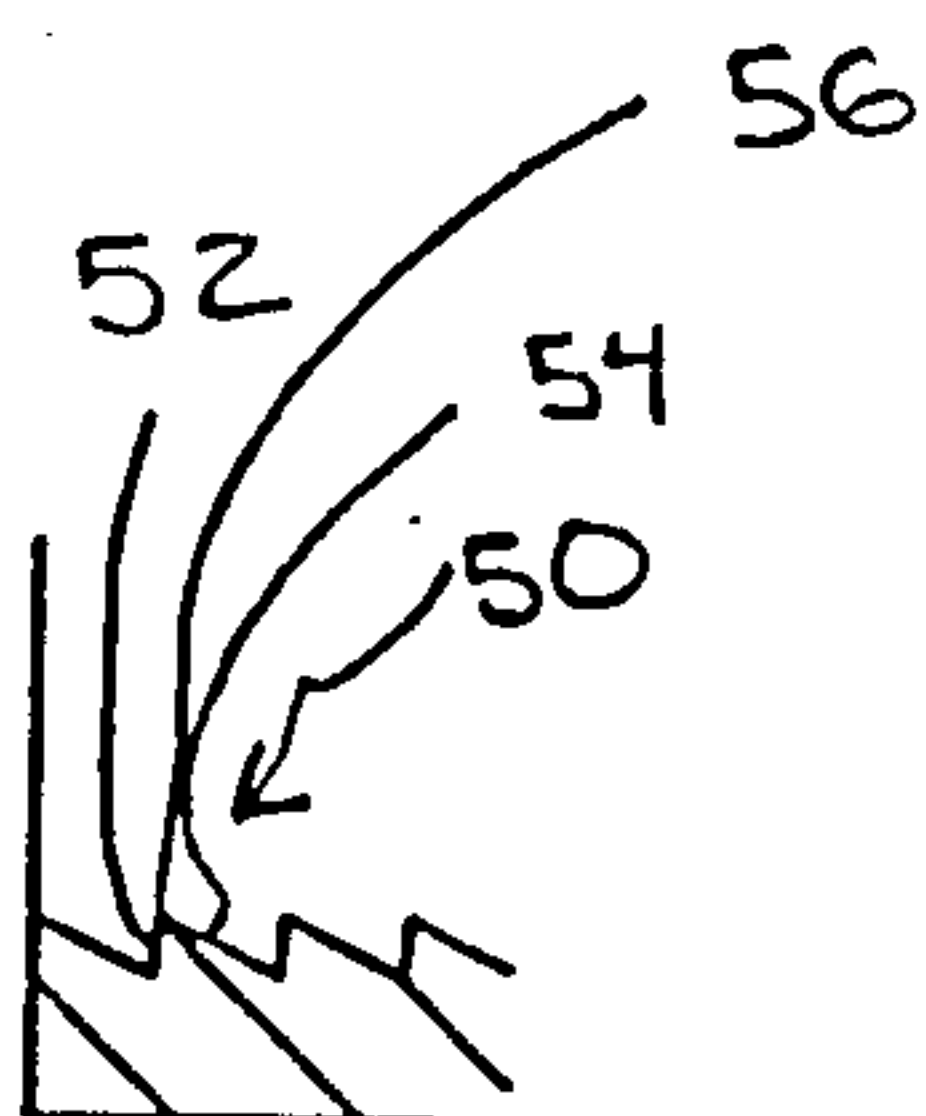

FIGURE 9

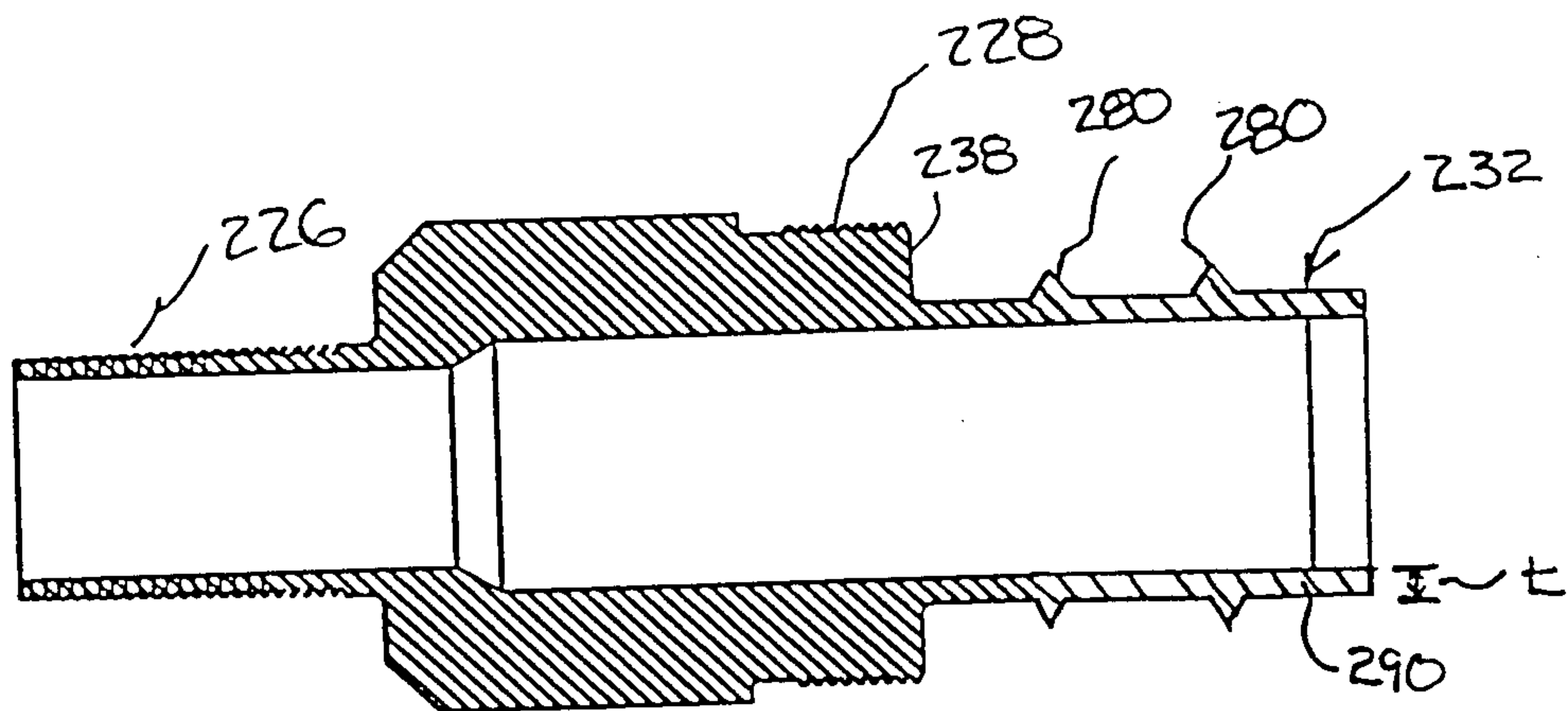
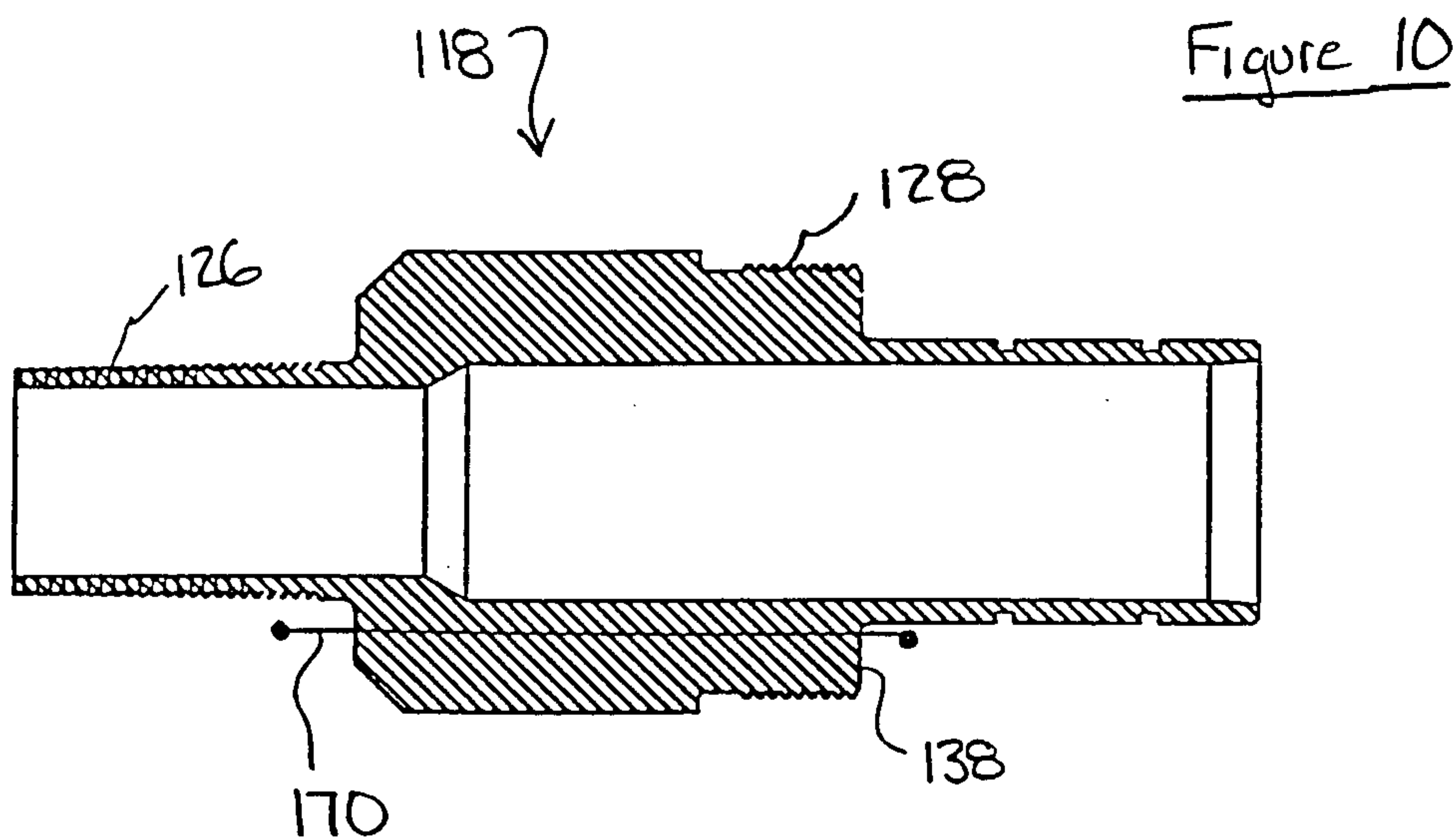

FIGURE 11

10 ?
↓

