



US 20020148858A1

(19) **United States**

(12) **Patent Application Publication**  
**Bertone**

(10) **Pub. No.: US 2002/0148858 A1**

(43) **Pub. Date: Oct. 17, 2002**

(54) **MULTI-FLAVOURED HOT BEVERAGE DISPENSER**

(57) **ABSTRACT**

(76) Inventor: **Claudio Bertone, St-Leonard (CA)**

Correspondence Address:  
**BLAKE, CASSELS & GRAYDON, LLP**  
**45 O'CONNOR ST., 20TH FLOOR**  
**OTTAWA, ON K1P 1A4 (CA)**

(21) Appl. No.: **10/164,571**

(22) Filed: **Jun. 10, 2002**

**Related U.S. Application Data**

(63) Continuation-in-part of application No. 09/629,449, filed on Jul. 31, 2000, now Pat. No. 6,419,120.

**Publication Classification**

(51) **Int. Cl.<sup>7</sup> ..... B67D 5/56**

(52) **U.S. Cl. .... 222/129.4; 222/146.5**

Discloses a multi-flavor hot beverage dispenser apparatus adapted to dispense a selected flavor hot drink. The dispenser apparatus has hopper to hold a base powder. The hopper includes a hopper dispenser outlet including a motor driven auger to dispense the base powder from the hopper and a hot water boiler and hot water dispense valve. The hot water boiler has controlled heating means to heat the water to the desired temperature. A plurality of liquid flavor dispensers is provided with one or more dispensers selectively activatable to dispense a flavor syrup to flavor the dispensed hot drink to the desired flavor. The liquid flavoring supply is separate from the base powder allowing a compact sized dispenser which requires minimal counter space that does not increase with increasing flavor selection offerings. A mixer mixes the hot drink constituents to produce the selected flavor of hot drink indicated by a user by depressing a dispense key corresponding to the desired size and flavor of drink to be dispensed. A portion controlled or push and hold dispense cycle is described. In addition, drink constituent supply sensors are disclosed which operate to disable hot drink dispensing when a supply is low.

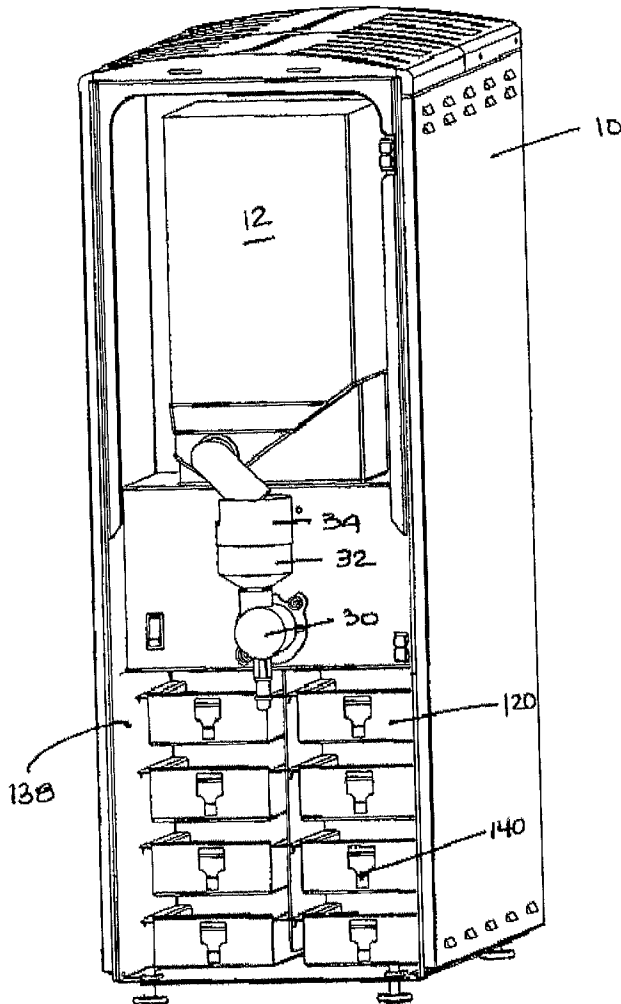

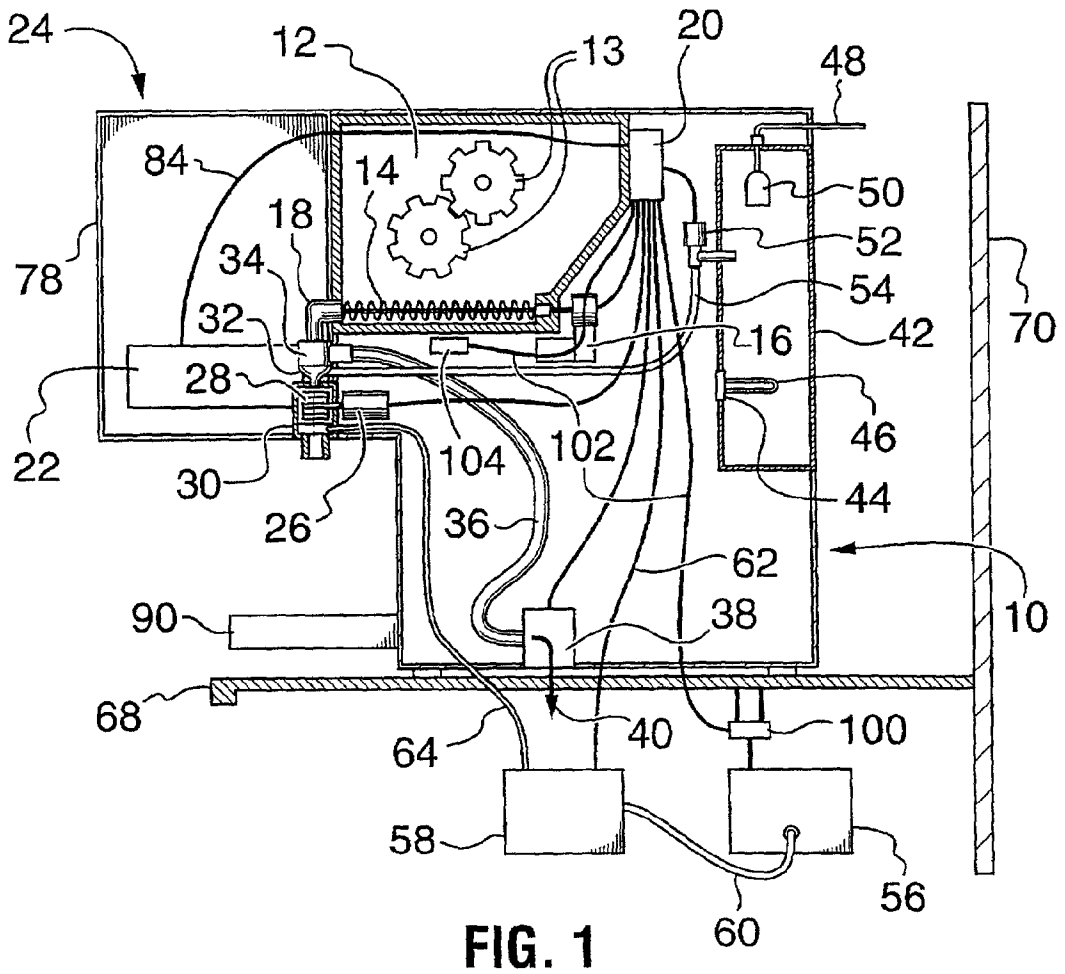

FIG. 1

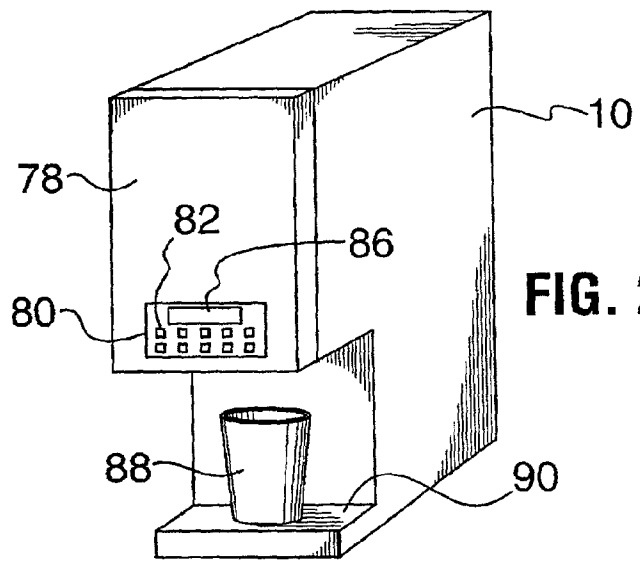
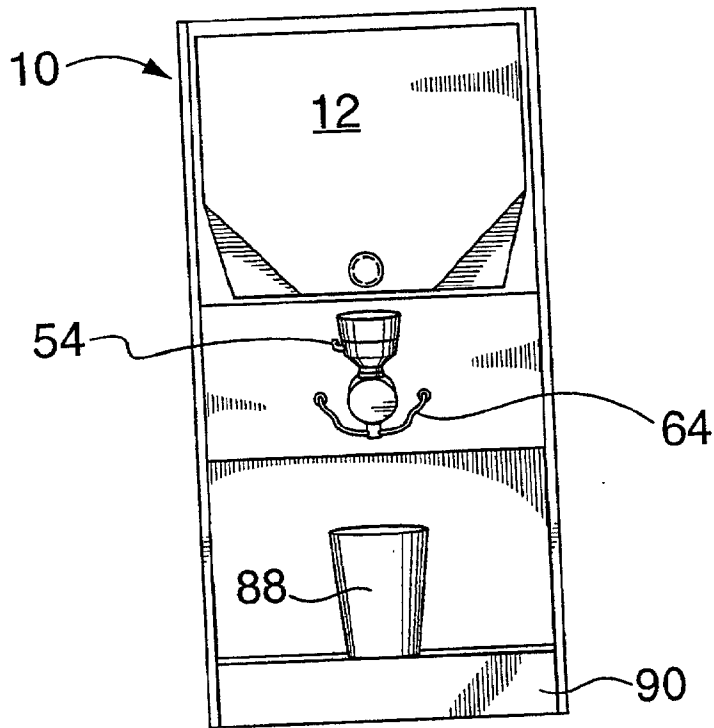
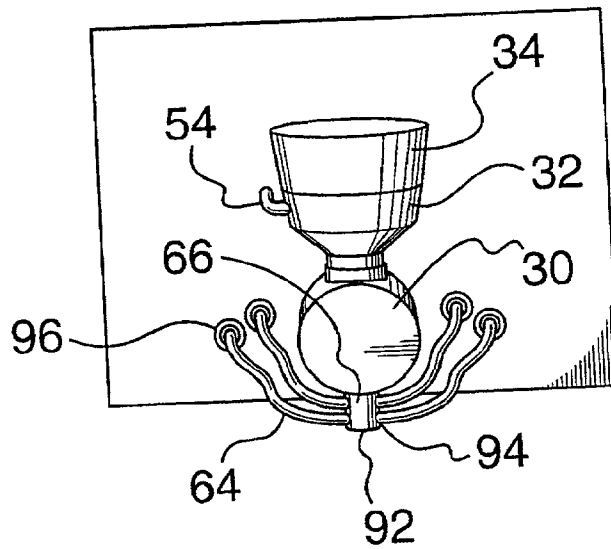

FIG. 2



**FIG. 3**



**FIG. 4**

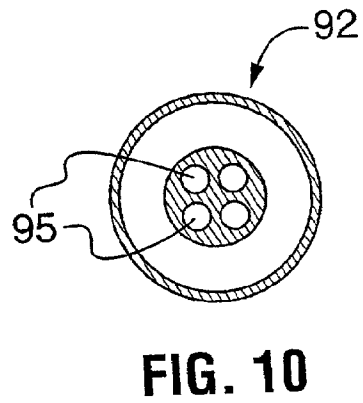
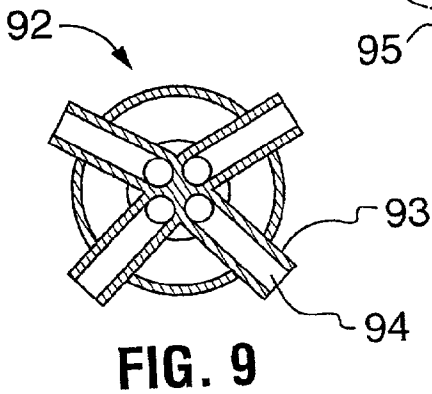
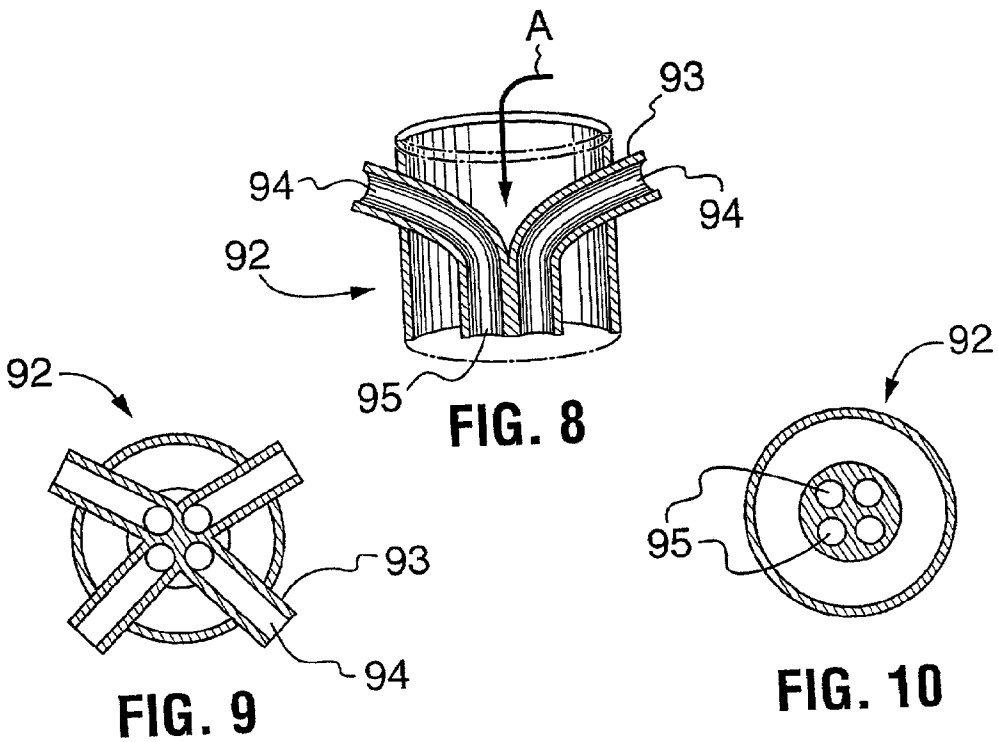
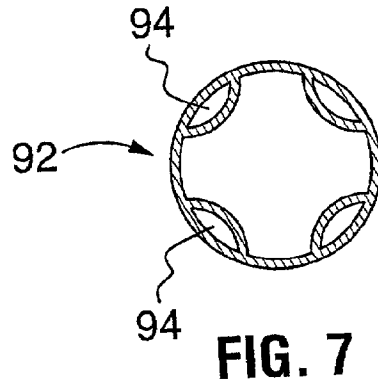
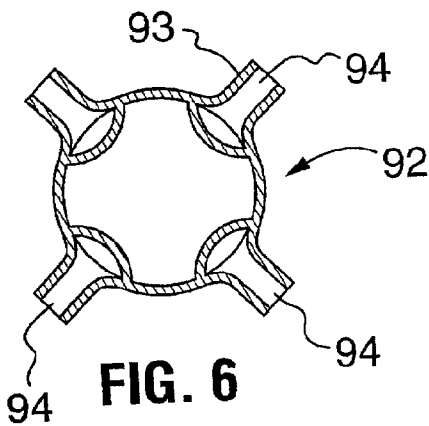
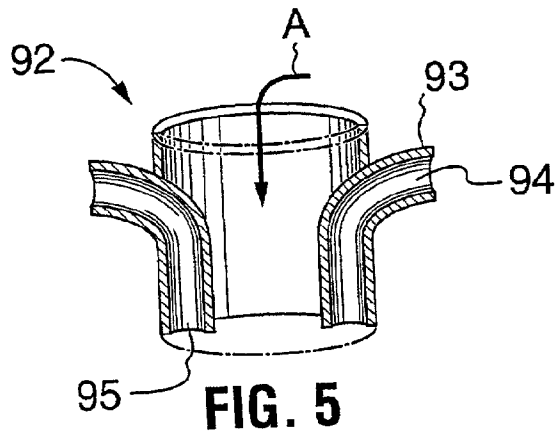

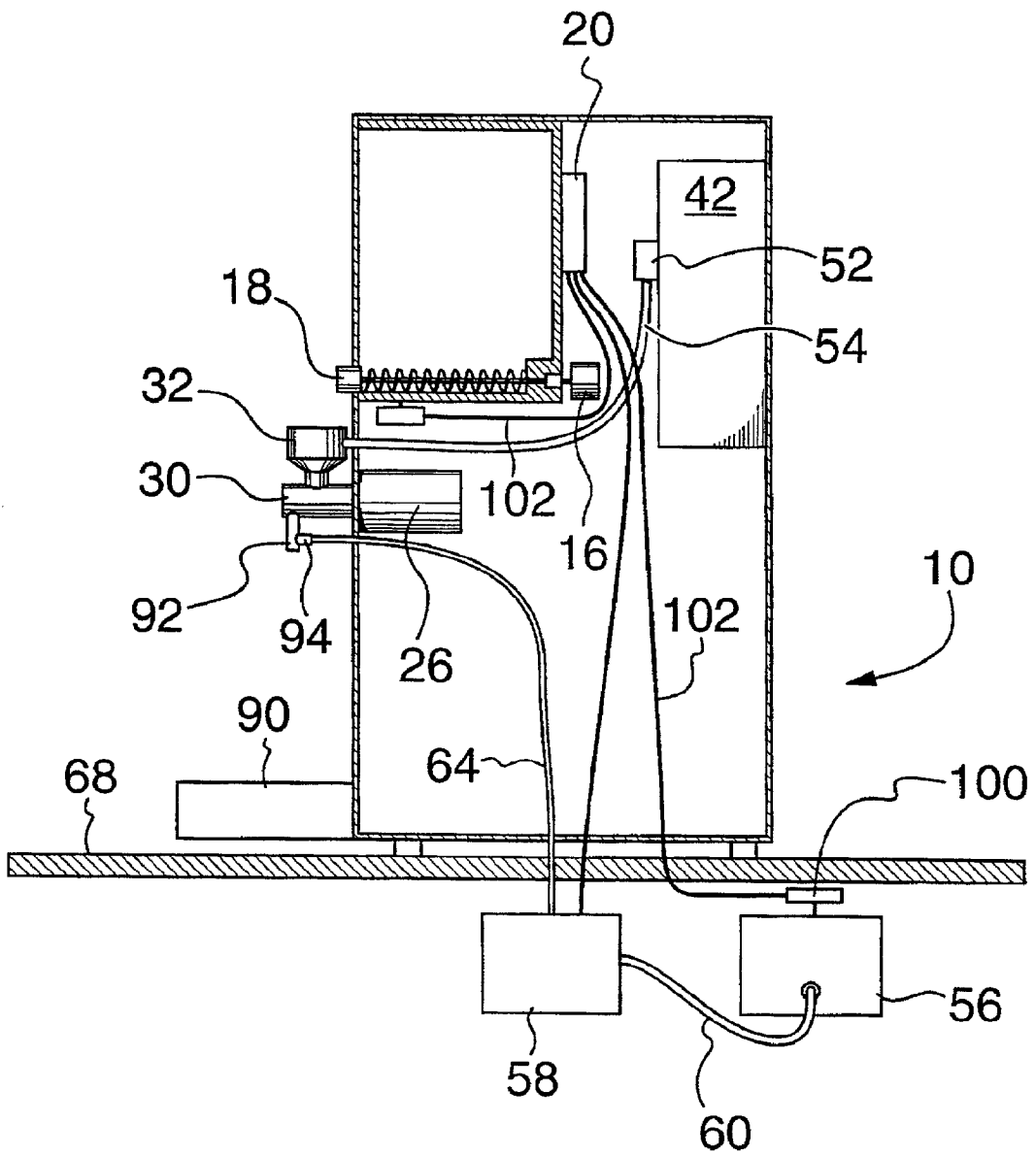
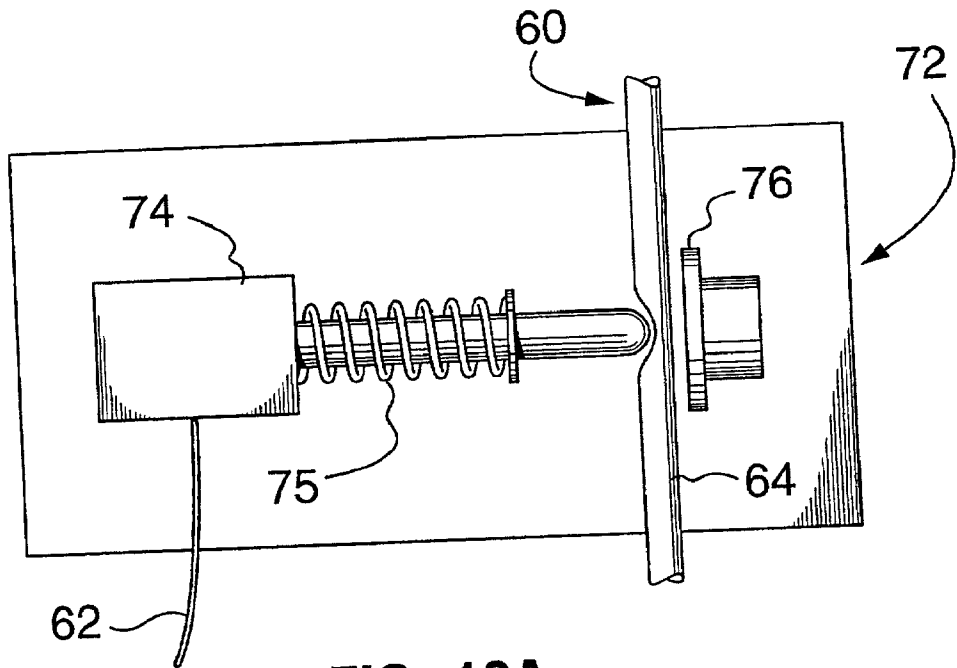
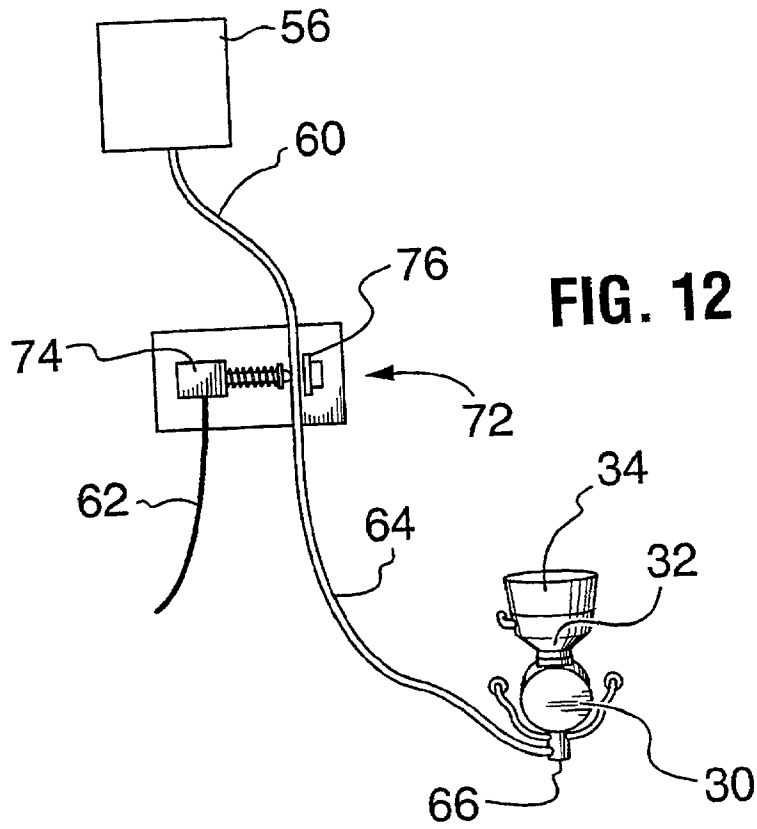

FIG. 11



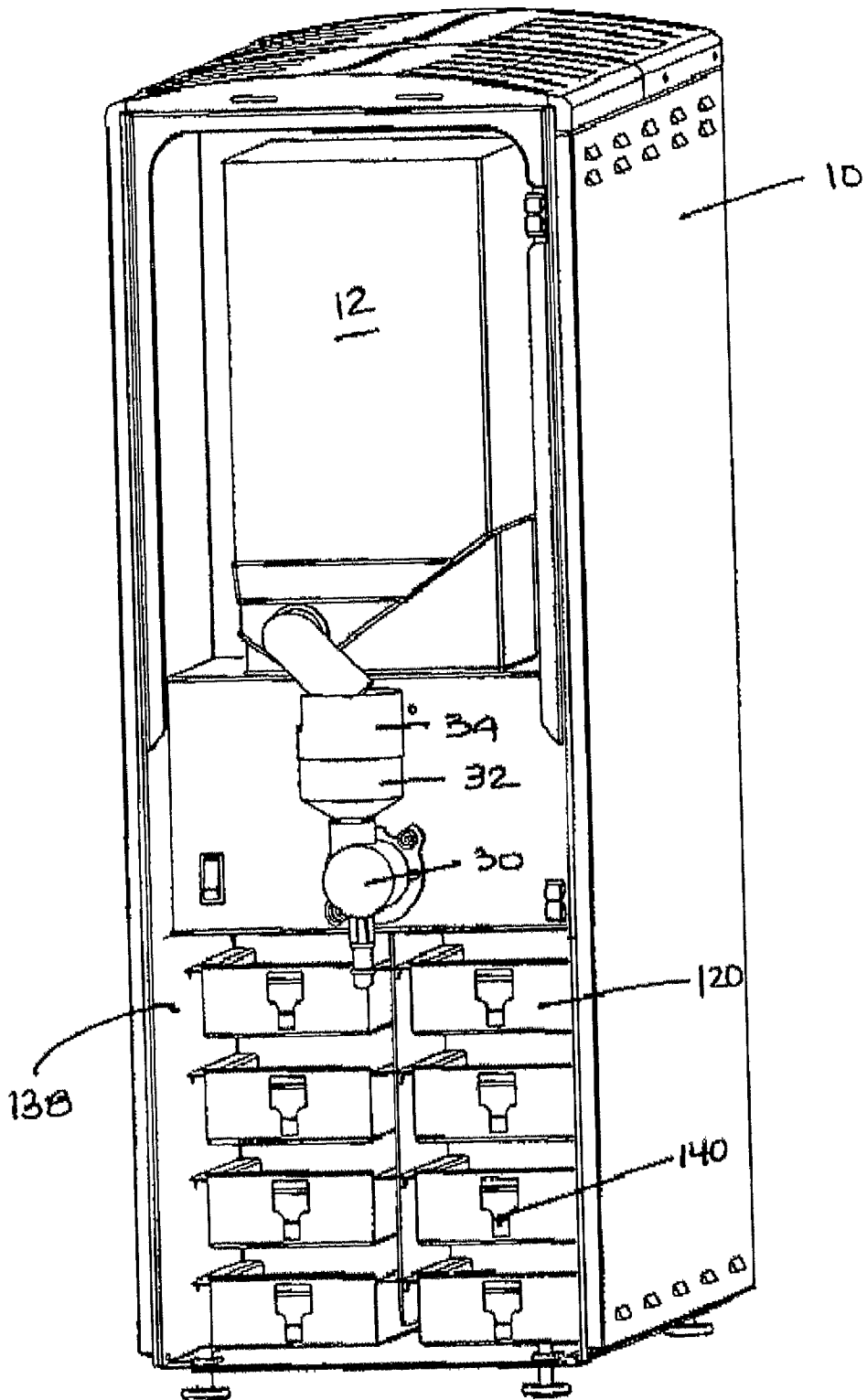

FIGURE 13

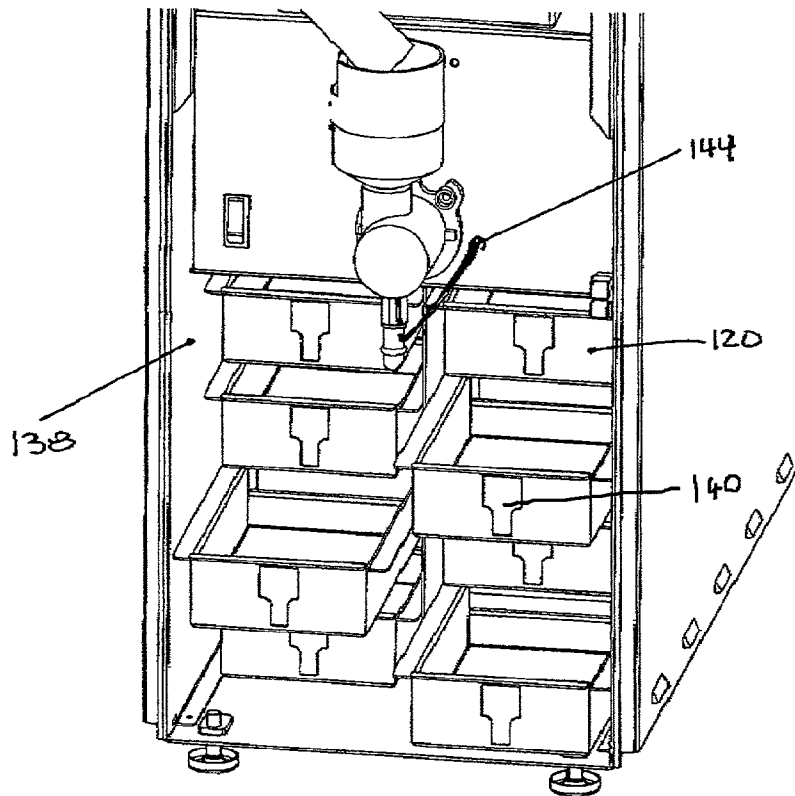

FIGURE 14

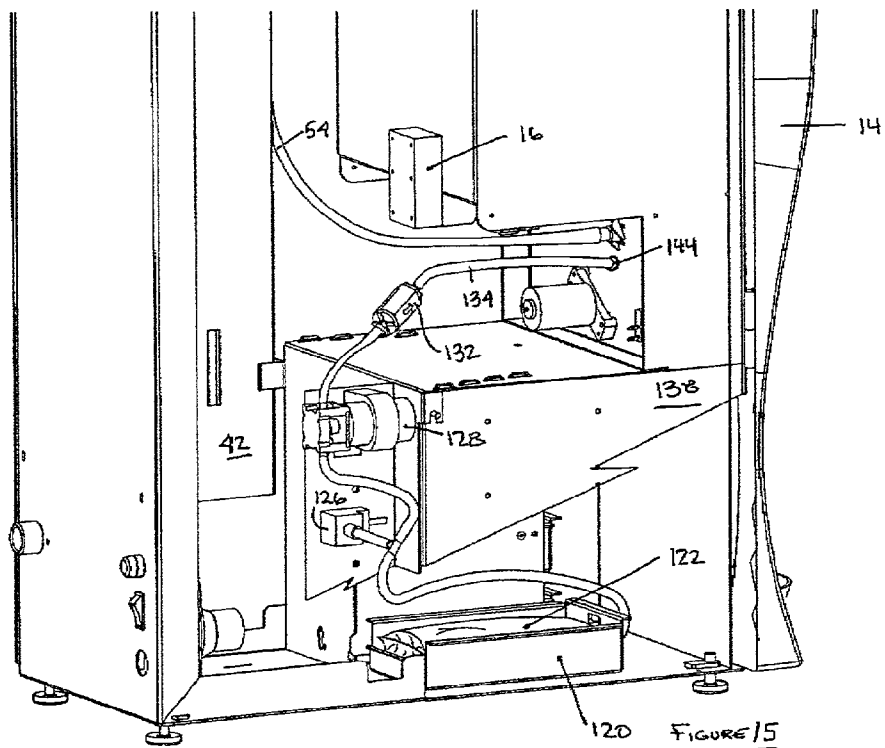

FIGURE 15

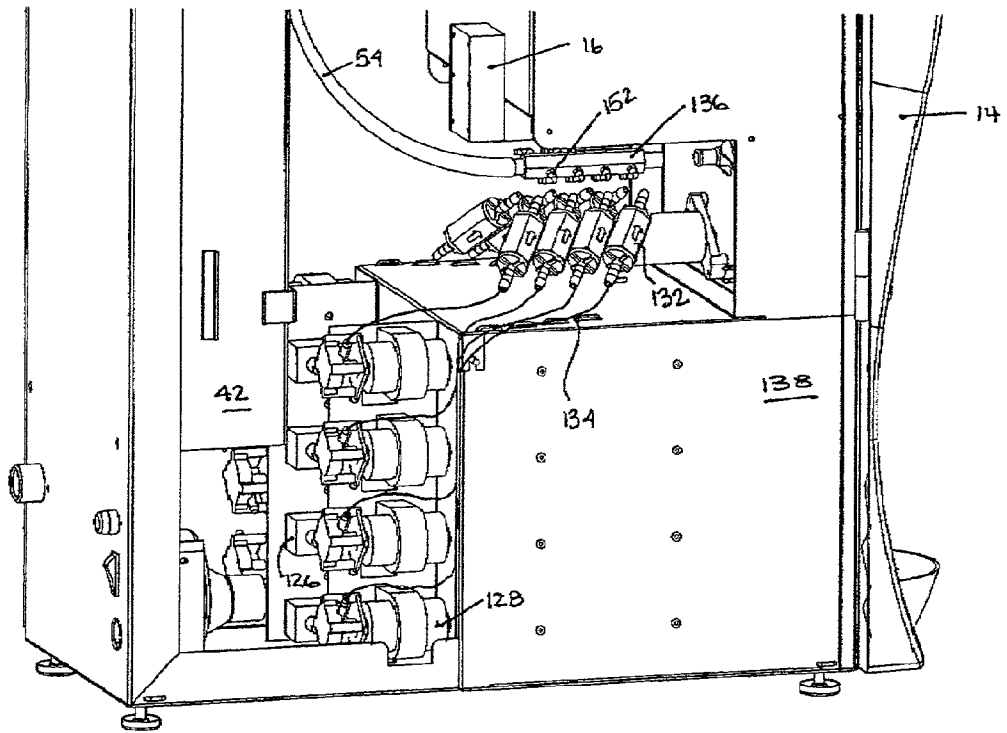

FIGURE 16

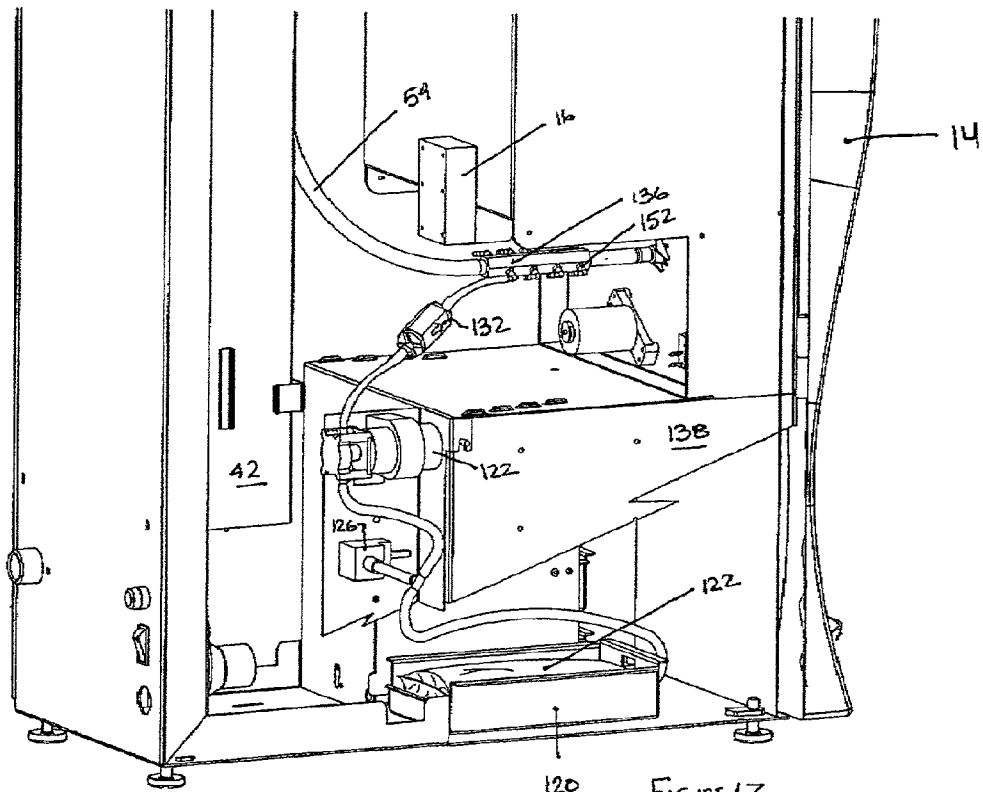
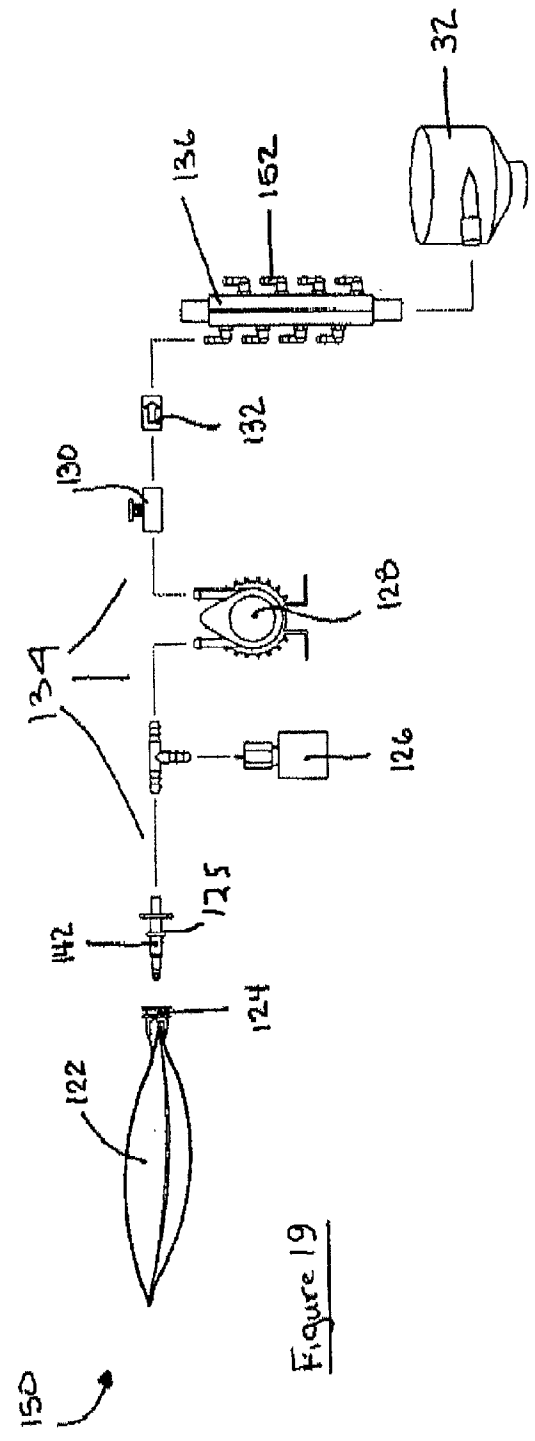
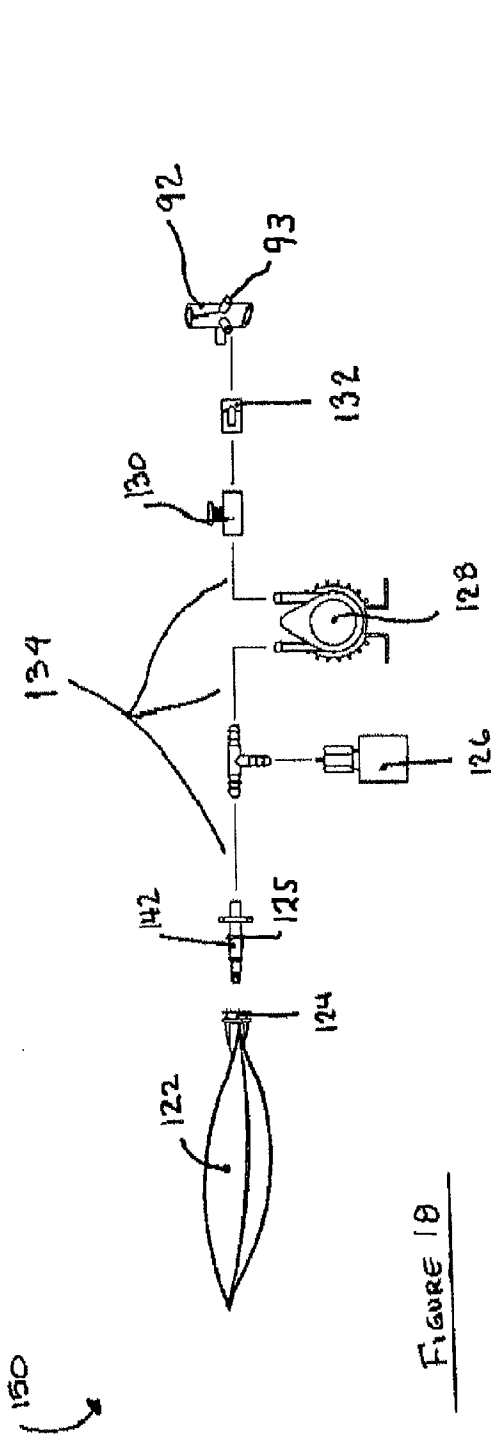

FIGURE 17



## MULTI-FLAVOURED HOT BEVERAGE DISPENSER

### CROSS-REFERENCES TO RELATED APPLICATIONS

[0001] This application is a continuation-in-part of co-pending application serial number 09/629,449 filed Jul. 31, 2000.

### BACKGROUND TO THE INVENTION

#### [0002] 1. Field of the Invention

[0003] This invention relates generally to apparatus for dispensing beverages constituted from hot water, powder and flavouring syrups. More particularly, the apparatus relates to automated dispensing apparatus to produce a hot beverage, such as, hot chocolate, hot cappuccino, hot powdered teas and the like, from heated water supply, a base powder and a flavouring syrup selected from one or more of a plurality of syrups.

#### [0004] 2. Description of the Related Art

[0005] Heretofore, hot beverages, such as hot Cappuccino and hot chocolate have been typically dispensed from automated dispensing apparatus having a product container, a boiler to heat water, a solenoid dispense valve, and a mixing system. Where the drink is a hot drink product, the flavouring product is typically a powder. Consequently, the powdered drink constituent, for example cappuccino, is maintained within a product hopper container. Where a variety of flavours are dispensed from the apparatus, a corresponding product hopper container is utilized for each flavour variety. When the product is to be dispensed, an activation button is depressed and the selected powder is dispensed from its hopper container into the mixing system. At the same time, a hot water solenoid valve opens to allow the entry of hot water into the mixing system. The powdered flavour, for example cappuccino, is mixed with the water and dispensed through the mixing system. As each of the available flavouring powders is maintained in a separate hopper, there are consequently several hoppers required to provide for the choice of drinks available from the dispenser. Thus, with the aforementioned dispensing systems available in the market today, the flavouring powders, for example, the cappuccino powders are pre-flavoured with a variety of flavourings. For example, providing a French vanilla cappuccino flavour requires French vanilla cappuccino powder and an associated product hopper container; an amarretto cappuccino flavour would be dispensed from the amarretto cappuccino powder product hopper container; and an Irish cream cappuccino flavour dispensed from the Irish cream cappuccino powder product container and so forth. An example of the type of multi-flavour beverage dispensers available is disclosed in U.S. Pat. No. 5,927,553 to Ford which provides a powdered beverage mixing and dispensing apparatus having three powdered flavour product hoppers each with associated mixing and dispensing apparatus.

[0006] Where the operator desires to offer a variety of flavours, generally three flavours are made available. Providing a multi-flavour dispenser capable of dispensing three flavours is considered the maximum number of flavours that can conveniently be dispensed from a multi-flavour dispenser. For multi-flavour dispensers, a three flavour dis-

penser has become a standard multi-flavour dispense product offering in the industry. The reason that the industry standard has been limited to three flavours, is that to add an additional new flavoured cappuccino to the machine, the dispenser will become bigger and wider. For example, the average hot drink or cappuccino dispensers available are approximately 14" wide. For a single flavour dispenser, a large product hopper container is provided which provides the greatest possible number of drinks dispensable without requiring refilling servicing. When a multi-flavour product dispense is provided, multiple product hopper containers are provided with a consequent decrease in the storage volume available to any one product. Thus, when the variety of product flavours available increases to three, the product hopper size for each individual product flavour is decreased. Consequently, the dispenser apparatus must be refilled more frequently to refill each of the smaller product hopper containers as they become emptied, unless, of course, the identical number of drinks of each flavour is dispensed.

[0007] To provide additional flavours beyond three requires the operator to purchase an additional unit to hold additional product hopper containers and associated equipment including an additional dispense valve, additional mixing system—in essence, a second dispenser apparatus. However, in the food service industry, counter space is a valuable commodity. Therefore, the operators are not inclined to add any additional flavours to support extra drink flavouring choice beyond three because the equipment to provide extra choices beyond three would take up too much additional counter space. Put another way, the incremental increase in returns from providing an extra flavour is not justified by the added revenues obtained from the use of additional counter space. As a result, the operator has turned away some customers who may appreciate alternate flavours because it wouldn't be worth the extra expense of taking up additional counter space.

### SUMMARY OF THE INVENTION

[0008] The present invention provides apparatus that conserves counter space while being able to provide multi-flavour products to their customers.

[0009] The present invention provides a multi-flavour dispenser that is adapted to dispense more than three flavours while conserving counter space to the same requirement as needed for a single flavour dispenser or a multi-flavour dispenser capable of dispensing three flavours.

[0010] Moreover, the present invention provides a multi-flavour dispenser apparatus which requires less frequent refill servicing to support a multi-flavour choice than traditional multi-flavour dispensing apparatus.

[0011] The apparatus of the present invention includes a system for dispensing a base powder, including means for dispensing hot water, a mixing system to mix the base powder and hot water, and a flavouring system which adds flavours to the base powder in order to dispense the desired flavour and a control activatable to dispense the base powder, the water and the flavour dosing systems and to mix the dispensed constituents. The flavourings are liquid flavourings that are located remotely from the counter top dispenser and the flavours are supplied to the dispenser for mixing with the other hot drink constituents by pump or gravity feed.

**[0012]** In one of its aspects, the invention provides apparatus to dispense a hot drink having a hopper with a hopper dispenser outlet including a motor driven auger dispenser along a bottom side thereof operable to dispense a base powder from the hopper dispenser outlet in response to a powder dispense signal and a hot water boiler with a water inlet and a water outlet, the boiler including means to apply controlled heating to water contained in the boiler and a hot water dispensing means operable to dispense water via the water outlet in response to a water dispense signal. The invention includes a plurality of liquid flavour dispensers, each liquid flavour dispenser is selectively activatable to dispense a flavour syrup from a flavour syrup supply. A mixer means has an outlet port and the mixer means is in communication with the hopper dispenser outlet, the water dispensing means and each liquid flavour dispenser. The mixer means is adapted to mix the hot drink constituents dispensed from these dispensers and provide the mixed hot drink constituents from the outlet port. Control means is included having user activatable selection means to produce the powder dispense signal, water dispense signal and a selected flavour dispense signal in response to user activation of the selection means.

**[0013]** In another of its aspects, the invention provides apparatus to dispense a hot drink comprising a hopper with a hopper dispenser outlet including a motor driven auger dispenser along a bottom side thereof activatable to dispense a base powder from the hopper dispenser outlet. A hot water boiler, with a water inlet and a water outlet, is included and has means to apply controlled heating to water contained in the boiler. The boiler has a hot water dispensing means activatable to dispense water via the water outlet. A plurality of liquid flavour dispensers is included, each liquid flavour dispenser is selectively activatable to dispense a flavour syrup from a flavour syrup supply and a mixer means having an outlet port. The mixer means is in communication with the hopper dispenser outlet, water outlet and each of the flavour dispensers and is adapted to mix the hot drink constituents dispensed from the dispensers and to provide the mixed hot drink constituents at the mixer outlet port. Also included is activation means to activate the auger, hot water dispenser and a selected liquid flavour dispenser in response to user manipulation whereby a user selected flavoured hot drink is dispensed from the mixer outlet port.

**[0014]** And in yet another of its aspects, the invention provides apparatus to dispense a hot drink comprising: a hopper with a hopper dispenser outlet including a motor driven auger dispenser along a bottom side thereof activatable to dispense a base powder from the hopper dispenser outlet and a hot water boiler with a water inlet and a water outlet, the boiler includes means to apply controlled heating to water contained in the boiler and a hot water dispensing means activatable to dispense water via the water outlet. The apparatus further includes a plurality of liquid flavour dispensers, each liquid flavour dispenser is selectively activatable to dispense a flavour syrup from a flavour syrup supply and mixer means having an outlet port. The mixer means is in communication with the hopper dispenser outlet, the water outlet and each flavour dispenser and the mixer is adapted to the mix hot drink constituents dispensed therefrom and provide the mixed hot drink constituents at the mixer outlet port. The dispenser apparatus also has a hopper sensor to produce an activation enable signal but, for a predetermined amount of a base powder contained in the

hopper, the hopper sensor will produce an activation disable signal. There are a plurality of liquid flavour dispensers, each liquid flavour dispenser is selectively activatable to dispense a flavour syrup from a flavour syrup supply; and user actuatable activation means to activate the auger, hot water dispenser and a selected liquid flavour dispenser in response to user manipulation and activation enable signal whereby a user selected flavoured hot drink is dispensed from the mixer outlet port.

**[0015]** In yet another of its aspects, the invention provides a liquid flavouring syrup connector adapted for use with hot drink dispense apparatus comprising a main body forming a passage connecting an inlet and an outlet, means to engage the inlet to a drink dispenser apparatus drink dispenser outlet and at least one liquid supply port formed in the main body with the port in communication with the passage all whereby flavouring syrup supplied to the liquid supply port will flow into the passage.

**[0016]** In yet another of its aspects, the invention provides a method of producing a flavoured hot drink of a selected flavour comprising the steps of: supplying a portion of a base powder, supplying a portion of hot water; supplying a portion of a selected flavouring syrup and mixing each supplied portion to form a flavoured hot drink.

**[0017]** And in yet a further aspect, the invention provides a method of producing a flavoured hot drink comprising the steps of: receiving a flavour selection; and mixing a controlled portion of a base powder with a corresponding controlled portion of hot water and corresponding controlled portion of a selected flavouring syrup.

**[0018]** In a further aspect, the invention provides a method of producing a flavoured hot drink comprising the steps of: receiving a drink selection; producing a flavoured hot drink supply by performing the steps of: supplying a base powder at a predetermined rate; supplying hot water at a corresponding rate; continuously mixing the base powder with the hot water to produce an intermediate hot drink supply. Next, supplying a hot drink flavouring corresponding to the received drink selection and admixing the hot drink flavouring supply with the intermediate hot drink to produce a flavoured hot drink supply and continuing the production of the flavoured hot drink supply until the volume produced corresponds to the received drink selection.

**[0019]** In another of its aspects, the system comprises (a) a source of liquid additive and an additive line, said source of liquid additive being in fluid communication with said additive line, said additive line comprising and additive outlet connected to the dispense tip open to the atmosphere, (b) an additive control connected to said additive line and a control board having at least one switch actuatable by user for allowing the user to select a hot beverage with liquid additive included, said additive control allows dispersion of a predetermined amount of the selected liquid additive through the dispense tip or additive manifold and into the stream of the hot beverage or hot water respectively.

**[0020]** More preferably, the system comprises a control board having a plurality of actuatable switches that are selectively actuatable by a user. The system may comprise a plurality of sources of liquid additive, a plurality of additive lines, and a plurality of additive controls. But will be used in conjunction with only one powder base hot beverage.

[0021] A detailed description of the preferred embodiments of the invention will now be provided with reference to the attached drawings in which like reference numerals have been used for like features of the embodiments throughout the various figures of the drawings.

#### BRIEF DESCRIPTION OF THE DRAWINGS

[0022] FIG. 1 is a partial cross-sectioned side view of a preferred embodiment of a multi-flavoured hot drink dispenser.

[0023] FIG. 2 is a perspective view of the dispenser of FIG. 1.

[0024] FIG. 3 is a front view of the dispenser of FIG. 1 without the front door.

[0025] FIG. 4 is an enlarged view of the mixer apparatus of FIG. 3.

[0026] FIG. 5 is a cross-sectioned view of the preferred embodiment of a flavouring dispenser nozzle.

[0027] FIG. 6 is a top view of the flavouring dispenser nozzle of FIG. 5.

[0028] FIG. 7 is a bottom view of the flavouring dispenser nozzle of FIG. 5.

[0029] FIG. 8 is a cross-sectioned view of an alternate embodiment of a flavouring dispenser nozzle.

[0030] FIG. 9 is a top view of the flavouring dispenser nozzle of FIG. 8.

[0031] FIG. 10 is a bottom view of the flavouring dispenser nozzle of FIG. 8.

[0032] FIG. 11 is a side view in partial cross section of an alternate embodiment of a multi-flavoured hot drink dispenser.

[0033] FIG. 12 is a perspective view of a second embodiment of a flavour supply system for use with a multi-flavoured hot drink dispenser.

[0034] FIG. 12A is an elevational view of the valve mechanism of FIG. 12.

[0035] FIG. 13 is a perspective view of an alternate embodiment of the dispenser shown without a front door providing an integrated additive liquid flavour supply.

[0036] FIG. 14 is an enlarged view of the additive liquid flavour cradle portion of FIG. 13 in which the liquid additive pouches are placed.

[0037] FIG. 15 is an enlarged perspective view of the liquid additive system in accordance with a first variant, one control has been included for simplicity, the side wall of the liquid additive chamber has been removed in order to view the liquid additive source of supply and supply pouch cradle

[0038] FIG. 16 is a close up side view of a second variant of the liquid additive system, depicting multiple liquid additive controls and lines coupled to an inline manifold of the hot water supply.

[0039] FIG. 17 is an enlarged perspective view of the liquid additive system in accordance with the second variant of FIG. 16, one control has been included for simplicity, the

side wall of the liquid additive chamber has been removed in order to view the liquid additive source of supply and supply pouch cradle.

[0040] FIG. 18 is a schematic view of an additive line with a first variant.

[0041] FIG. 19 is a schematic view of an additive line with a second variant.

#### DETAILED DESCRIPTION OF THE PREFERRED EMBODIMENTS OF THE INVENTION

[0042] FIG. 1 shows a partial cross-sectioned side view of a preferred embodiment of a multi-flavoured hot drink dispenser constructed in accordance with the principles of the present invention. The dispenser is generally depicted by reference numeral 10 and uses a base powder dispensing system comprising a hopper 12 to hold a base powder. Typically, the base powder will be an unflavoured base powder and the flavour of the hot drink that will be produced will be provided by a flavouring syrup. It will be understood, however, that the base powder may also be a hot chocolate drink powder that is further flavoured by a selected flavouring syrup. The hopper 12 has been cross-sectioned in this view to show internal components. Hopper 12 contains an auger drive 14 which is activated by auger motor 16 to dispense powder out of the powder dispensing nozzle or hopper dispenser outlet 18. Auger motor 16 is controlled and powered by main control board 20. Main control board 20 is electrically coupled to a keypad, the backside of which is visible at 22 on the inside of the door 24 of the dispenser. Contained within hopper 12 are agitators 13 which rotate when auger 14 is activated to cause the powder contained within the hopper to become loose and free and available freely for pickup by auger 14.

[0043] Both the base powder and the water enter the mixing system where they are mixed and blended together. The mixing system preferably includes a vacuum funnel 34 which is attached to a blower system. The blower system is employed to extract any powder particles that may be dispersed into the air as the powder is dispensed from the hopper dispenser outlet 18 into the mixing system. In the preferred embodiment of the invention, a vacuum funnel 34 is provided to which a vacuum discharge line 36 is connected. Vacuum discharge line 36 is preferably a flexible tubing which extends between vacuum funnel 34 and blower 38. When activated, blower 38 draws air from vacuum funnel 34 and expels that air via tube 36 and blower 38 outward from the mixing apparatus through a discharge outlet and generally in the direction of arrow 40. Thus the vacuum system is activated to extract any powder particles that may be dispersed into the air as the powder is dispensed from the hopper dispenser outlet 18 and expel such powder particles from the dispenser 10 through the discharge outlet.

[0044] The dispenser 10 also includes a hot water dispensing system which is provided to reconstitute the base powder drink constituent. The hot water system comprises a boiler 42 to hold and provide a means for heating the water. The boiler 42 has been shown in sectioned view in this Figure to better illustrate its construction. A heater control 44 senses the temperature of the water and controls the energization of the heating elements 46 which are submersed in the water. A fresh water supply 48 is connected to a source of pres-

surized domestic water. Water flow into boiler 42 is controlled by means of a level sensing valve 50 that maintains the water level within boiler 42. The boiler 42 includes a dispense valve 52 which is controlled by control board 20 and includes a solenoid means to activate dispense valve 52 to open and close the water supply between boiler 42 and the hot water dispense line 54. Hot water dispense line 54 is connected to mixing funnel 32 whereby when dispense valve 52 is opened, hot water is dispensed into mixing funnel 32 where it will flow into whipping chamber 30 to be mixed with the base powder dispensed thereinto from hopper dispenser outlet 18. The duration and, therefore, the amount of water dispensed by dispensing valve 52 is controlled by main control board 20 and will vary depending on the size of the beverage which the user has selected by depressing a selection key on the keypad on the exterior of the front door 24.

[0045] The length of time during which auger 14 will be driven by the auger motor 16 depends on the type and size of drink selected by the user via the keypad 80. The auger 14 controls the amount of base powder that will be dispensed and will depend on the size of drink selected and the type of beverage product flavouring, the amount of base powder dispensed is pre-set to yield the optimal consistency and taste of the hot drink product dispensed. The amount of base powder dispensed by auger 14 can be varied for each and every one of the drink selections the user makes.

[0046] When the base powder is dispensed from hopper 12, whipper motor 26 is also activated causing whipper blade 28 to rotate within whipping chamber 30. Whipping chamber 30 has been shown in cross-sectioned form to show whipper blade 28. The base powder emanating from the powder hopper dispenser outlet 18 falls into the mixing funnel 32 where it passes therethrough into whipping chamber 30. Both the base powder and the hot water entering into the mixing system, which is comprised of mixing funnel 32, whipping chamber 30 and, in the preferred embodiment, vacuum funnel 34, come into mixing contact therein to enable the hot water and the base powder to intermix thoroughly. The mixing funnel 32 and whipping chamber 30 are constructed from a plastic material as, preferably, is the whipping blade of whipper 28. Thus, the dispensing of a hot beverage by depressing a button on keypad 80 will result in the simultaneous activation of dispensing valve 52, auger motor 16, whipper motor 26 and blower 38. The associated control lines extending to and from control board 20 and the electrical apparatus under its control are shown in FIG. 1 for clarity. Also controlled by control board 20 is the flavouring system, one flavour of which is shown by way of example in FIG. 1.

[0047] The apparatus of the flavouring system uses a liquid flavouring syrup contained within flavour containers, such as a flavour container 56. Flavour container 56 is in communication with a pump system 58 via supply line 60. When activated by control line 62, the liquid flavour syrup from the flavour container 56 is dosed into discharge line 64 where it is transported to be dispensed with the hot drink emanating from discharge nozzle 66 of the dispenser. As will be appreciated, the flavour discharge line 64 will be filled with the flavouring syrup when the dispenser 10 is set up and in use. Therefore, the quantity of flavouring syrup discharged by pump system 58 into one end of discharge line 64 will cause a corresponding amount of flavouring syrup to

be discharged from the flavour discharge line 64 at the dispenser nozzle and of the flavour discharge line 64. In this way, the exact dosage or metering of the flavouring syrup into the drink dispensed is controlled. Flavour lines 64 pass through the frontal portion of dispenser 10 where they are supplied to the dispensing system of the dispenser.

[0048] In the arrangement of the flavour system shown in FIG. 1, which is the preferred embodiment, the flavour pump system 58 and associated flavour syrup containers 56 are disposed below counter 68. As will be understood by those skilled in the art, other suitable locations for the flavour syrup containers and pump system remote from the dispenser 10 can be used as well. For example, on a wall 70 behind the dispenser 10 or within the interior of the door 24 of the dispenser 10. Another embodiment of a flavour dispensing system that is wall mounted will be explained in more detail with reference to FIG. 12.

[0049] FIG. 2 shows a perspective view of a hot drink dispenser 10. The dispenser 10 has a front door 78 which is shown in the closed position in FIG. 2. Located on the front door 78 is a keypad 80 which includes a plurality of buttons 82 which are user actuable to initiate dispensing of a hot drink from the dispenser 10. The selected drink is requested by depressing one of the keys 82 located within the keypad 80. The keypad 80 provides separate keys to enable the user to select the desired beverage. The keys enable the user to select what size, for example, small, medium or large, and what flavour drink the user wishes to be dispensed. The keypad 80 is in communication with the main control board 20 by means of a control line 84 shown for example in FIG. 1. The keypad 80 can include a display 86 to provide information to the user, for example, any messages that the control board is programmed to display. The keypad 80 can also be used as a means to program the control board 20 by providing a keyed lock or setup key sequence. When the key sequence is depressed, the control board 20 is placed in programming mode. For example, to set drink parameters such as hot water amount, base powder amount, flavouring amount and so forth.

[0050] Based on the drink selection made by the user as indicated by depressing a selected key of keyboard 80, the user selection is communicated to control board 20. Control board 20 then initiates a dispense sequence to control the operation of dispenser 10. The control sequence includes determining and dispensing the quantity of base powder to dispense for the selected beverage, the quantity of water that is required for the selection and the type and quantity of flavouring syrup required for the selection. The control can be effected by control board 20 based on a portion controlled basis. That is to say, when the user depresses a key to make a selection, the controller doses out the hot drink ingredients to produce a hot drink of the size and flavour selected by the user. Alternately, the keys of keypad 80 can be adapted to dispense a drink on a push and hold basis. That is to say, the selected drink flavour will be dispensed for as long as the user depresses the selected key of keypad 80. In either event, the drink is dispensed into a cup 88. In the preferred embodiment, cup 88 rests on a drip tray 90 adapted to support the cup and provide a catch basin for any overflow.

[0051] FIG. 3 shows a front view of the drink dispenser of FIG. 1 with the front door removed for clarity. Hopper 12 extends to substantially occupy all of the upper interior

space of the dispenser **10** allowing hopper **12** to hold as generous a supply of base powder as the dimensions of dispenser **10** permit. As there is only one large hopper **12** in the dispenser, the maximum amount of base powder practicable for a given dimensioned dispenser **10** is facilitated, consequently, reducing the frequency of the need to refill powder into the dispenser **10**. Also shown in the figure are flavour lines **64** that pass through the frontal portion of dispenser **10** where they are supplied to the dispensing system of the dispenser.

[0052] FIG. 4 shows a close up view of the dispenser in accordance with the preferred embodiment of the invention. The dispenser has a flavouring dispenser nozzle **92** which attaches to the dispenser nozzle exit **66** of the whipping chamber **30**. Flavouring dispenser nozzle **92** has a plurality of flavour supply ports **94** extending from and in communication with the main discharge passage formed by the main body of the flavouring dispenser nozzle **92**. The flavouring dispenser nozzle **92** is dimensioned to be slidably, grippingly retained on exit dispensing nozzle **66** of the mixing chamber **30**. The number of flavour supply ports **94** provided on flavouring dispenser nozzle **92** will be determined by the number of flavours which it is desired to be dispensed by the dispenser **10** to which it is fitted. Each flavour syrup arrives at the flavour dispensing nozzle **92** via its associated flavour discharge line **64**. And each flavour discharge line **64** passes through the front portion of the dispenser as shown. For example, two flavour lines **64** are shown in FIG. 3 and four flavour lines **64** are shown in FIG. 4. Preferably, the pass through location of flavour line **64** includes a grommet **96** for protection of the supply line **64**. Hot water is supplied to the dispensing apparatus from the hot water dispenser line **54**.

[0053] FIG. 5 shows the flavouring dispenser nozzle **92** in cross-sectioned view for clarity of understanding its nature of construction. The flavouring dispenser nozzle **92** is preferably constructed from a plastic material. The stems forming flavour supply ports **94** are preferably, on the flavour supply port inlet portion **93** extending from the dispenser nozzle **92**, tubular and have an outside diameter dimensioned to frictionally engage the inner diameter surface of the flavour discharge lines **64** when coupled thereto. The outlet portion **95** of each flavour supply port is proximal to the outlet of the passage, generally depicted by arrow "A" formed by the main body of the dispenser nozzle **92**. The flavouring dispenser nozzle or flavouring connector provides a number of flavour supply ports which stem from the location where the flavouring is supplied to the hot drink before it is dispensed from the dispenser. Thus the flavouring connector port configuration is adapted to present a point of entry for the flavour which will not permit cross-contamination of one flavour with another. The flavouring connector can be with a varied number of stems **93** and corresponding supply ports **94** to enable any practical number of flavour ports to be provided to add the flexibility of providing for additional flavours.

[0054] While the depiction of the embodiment of the flavour connector shown in FIGS. 5, 6 and 7 show the flavour supply ports extending into the interior volume of the passage A, it will be understood that the body of the connector **92** forming passage "A" may be constructed to provide a smooth circular interior surface shape with the stems **93** extending along the exterior of the connector **92**.

[0055] FIGS. 6 and 7 show a top and bottom view respectively of the flavour connector of FIG. 5.

[0056] FIG. 8 is an alternate embodiment of the flavour connector of FIG. 5. In this embodiment, stems **93** forming the flavour supply ports **94** are positioned proximal to each other in the central region of passage "A" of the flavour connector **92**. In this embodiment, as with the embodiment of FIGS. 5, 6 and 7, the discharge or outlet **95** of each flavour supply port **94** is proximal to the exit or discharge of the passage "A" formed by the connector **92** to prevent contamination or cross-mixing of the flavouring syrups from one dispense cycle to the next.

[0057] FIGS. 9 and 10 show a top and bottom view respectively of the flavour connector of FIG. 8.

[0058] As will be understood, it is possible to permit a combination of flavours to be supplied to the hot drink to be dispensed. That is, multiple flavours can be mixed into one beverage. For example, should a customer want a French vanilla and Irish cream cappuccino mix, the dispenser apparatus can proportionately add mixes of each of the flavours into the hot drink dispensed to satisfy the customer request.

[0059] The apparatus and control of the present invention permit an operator to purchase a base unit that can include a number of flavours, for example, four flavours. Additional flavours may be added to the system without requiring additional counter space by simply attaching a flavouring dispenser nozzle **92** that is provided with the number of flavour supply ports **94** to accommodate the additional flavours desired. Each flavour will require appropriate supply apparatus including a flavour discharge line **64**, a pump **58**, a supply line **60** and the flavour syrup itself in a flavour container **56**.

[0060] FIG. 11 shows an alternate embodiment of the dispenser **10** which does not have a powder vacuum discharge system. The other elements of the system remain the same. The preferred embodiment of the flavouring system is to include a pumping system **58** for each flavour syrup **56** that is to be dispensed by the dispenser **10**. When a selection button on the keypad **80** is depressed, the selected flavour for the hot drink to be dispensed is provided to the dispenser **10** by means of the pump system **58**. A plurality of pumps **58** is provided corresponding to the selected plurality of flavouring syrups **56** to be available as flavours for dispenser **10**.

[0061] FIG. 12 shows an alternate embodiment of the apparatus to deliver the flavour syrups to the dispenser. The arrangement of FIG. 12 provides an elevated location for the flavour syrup containers **56**, only one of which is shown in the figure, to provide sufficient head or distance between the flavour container **56** and the mixing apparatus **28**, **32**, **34**, and **66** to permit gravity feed of the flavouring syrup. The flavour supply line **60** leads to an aseptic control valve **72**. Control valve **72** meters the flavouring fluid supplied to the flavour discharge line **64** thereby to control the quantity of flavouring syrup delivered to the dispensing apparatus. In this embodiment of the flavour delivering system, each syrup flavour tube, only one of which **60** is shown in figure, runs through its own independent aseptic valve **72** or pinching mechanism. The valve mechanism **72** can include a normally closed valve, for example, a spring-loaded push-pull solenoid actuated rod **74** and backstop **76** which is

shown in enlarged view in **FIG. 12A**. The pinch mechanism **72** is used to stop the flow of flavouring syrup to the dispenser apparatus. When the pinch mechanism **72** is at rest, all of the spring load of the solenoid actuated rod **74** is applied to the tubing to close it off from fluid communication between supply line **60** and flavour discharge line **64**. Thus, the compression spring **75** forces the rod against the back-stop to pinch the tube shut. When the dispenser apparatus is activated in response to the selection made by the user, the solenoid actuated rod **74** will be activated by the control module **20** (of **FIG. 1**) via control line **62** for a predetermined period of time to allow a metered dose amount of flavouring syrup from the flavour container **56**, to enter into flavour discharge line **64**. As the flavour syrup enters the discharge line **64**, it will be drawn by gravity into and toward mixing apparatus **66** to supply a metered dose of flavouring syrup to the drink being dispensed.

**[0062]** Product Empty System

**[0063]** The apparatus of the present invention preferably includes sensors to monitor the hot drink ingredient supply. The sensors work in conjunction with the main control board **20**. Thus the apparatus of the invention serves the needs of the service operators by including apparatus designed to inform a user when the dispenser apparatus is out of any product. The dispenser **10** preferably includes sensors to produce activation enable and activation disable signaling which is used to enable and to prevent the commencement of a product dispense cycle. When activation disable signaling is produced, there is insufficient drink ingredients to produce the selected drink.

**[0064]** In the embodiment of **FIG. 1**, for the sensor apparatus provided for the base powder, the base powder hopper **12** rests on a weight sensor **104** which is set to a threshold amount to sense when the base powder product has run low. When the low level has been reached, the main control board **20** a disable condition is signaled via sensor line **102** which causes the main control board to deactivate a dispense cycle for all of the selection buttons on key pad **80**. All buttons are deactivated since the base powder is used to make all of the beverages that can be selected from the selection keypad **80**. When the weight of the base powder hopper **12** falls below the pre-set threshold, the sensor signaling on line **102** preferably causes the main control board **20** to produce a message on the keyboard display **86** to announce to the user that product is not available. On the other hand, when the base powder hopper rests weight sensor **104** with a sufficient weight to exceed the threshold amount, the weight sensor **104** will produce an activation enable signal that causes the main control board to activate a dispense cycle for all of the selection buttons on key pad **80**.

**[0065]** Also, each individual flavouring syrup container **56** is equipped with a sensor mechanism to sense when the flavouring syrup pouch or container is empty. In the preferred embodiment of **FIG. 1**, each pouch or container **56** is suspended from a weight sensor **100**, which measures the weight of the flavouring syrup container. In the embodiment of **FIGS. 15-19** the flavour supply lines include a vacuum switch **126** which measures the pressure in the supply line extending between the flavour pouch **122** and pump **128**. When the flavour pouch is empty, operation of pump **128** will induce a vacuum in the supply line and the main control

board will be signaled with a flavour empty signal. In the embodiment relying on a weight sensor, when the weight of the flavour container **64** falls below a pre-set threshold, main control board **20** is signaled via sensor line **102** with an activation disable signal. The activation disable sensor signaling on line **102** causes the main control board **20** to produce a message on the keyboard display **86** to announce to the user that the selected product is not available. The activation disable sensor signaling on line **102** also causes main control board **20** to de-activate and ignore the corresponding drink selection switch or key depressed by the user on the key pad **80**. Therefore, if a selected flavour syrup is empty, the corresponding beverage cannot be dispensed. On the other hand, when the weight of the flavour container **64** is above the pre-set threshold, main control board **20** is signaled via sensor line **102** with an activation enable signal thereby permitting the unimpeded dispensing operation of the dispenser **10**.

**[0066]** Referring to **FIG. 13** and **14**, hot beverage dispenser **10** is shown with an open front door **14**. Upon opening the front door **14** the user has access to the base powder hopper **12**, which can be removed, refilled and cleaned. Also evident is, the hot beverage mixing system which comprises the vacuum funnel **34**, the mixing funnel **32** where the hot water is introduced to the powdered beverage, the whipping funnel **30** where the powder and water are whipped together. The user also gains access to the liquid additive compartment **138**. Housed within the liquid additive compartment **138** are multiple (from 1 to 8 or more) additive pouch cradles **120**. The cradles **120** are designed so that they can easily slide in and out of the flavor compartment **138**. This facilitates the loading of full liquid additive pouches **122** and the discharging of empty liquid additive pouches **122**.

**[0067]** For the purpose of this preferred embodiment we are referring to a source of liquid additive as a flexible pouch, which can vary in size and volume. As can be seen in **FIG. 8**, connected to the flexible pouch **122** on one end is a female fitment **124** with guide ridges **125** on each side. The pouch and fitment system facilitate the loading and unloading of pouches because a reusable male fitment **142** connected to the inlet end of the liquid additive tube **134** can easily be inserted and extracted from the female fitment **124** on the flexible pouch **122**. To facilitate the exchanging of pouches **122**, each of the cradles **120** has been designed with an entry slot **140** which is dimensioned to firmly engage the ridges on the female fitment **124** of the pouch **120**. This prevents the fitment **124** from moving in and out of the cradle so that the male fitting **142** can be easily inserted. It is understood that alternate sources of liquid additives can be implemented other than a flexible pouch such as described.

**[0068]** In operation the user depresses one or more of the switches **82** on door **14** corresponding to the selected flavour drink and the control **20** regulates the on/off time of the solenoid valve **52**, which opens and allows hot water to flow through the hot water supply line **54**. The Control **20** also regulates when the liquid additive system **150** will be activated, what part will be activated, for how long and in what sequence.

**[0069]** **FIG. 16**, depicts an enlarged view of the hot water supply line **54**, the auger motor **16** which drives powder out of the powder hopper/container **12** (not in view). Also in

view are the hot water boiler 42 and a side view of the liquid additive compartment 138. Also in view is the liquid additive system 150 which is made up of a plurality of pumps 128, vacuum switches 126 and check valves 132. One pump, vacuum switch and check valve is provided for each corresponding flavour cradle 120 of the liquid additive compartment 138 to supply the selected liquid additive to manifold 136. For clarity, the tubes connecting valves 132 to manifold 136 have been omitted in this figure.

[0070] Referring to FIGS. 17 to 20, details of the liquid additive system are shown for each of the corresponding flavour cradles. For each flavour, the liquid additive system 150 comprises a pump 128 in fluid communication with a source of liquid additive 122 by means of an additive outlet/female fitment 124. The male fitting 142 is connected to the inlet of the additive line 134. A vacuum switch 126 is mounted perpendicularly to the additive line 134 between the source of liquid additive 122 and a pumping means 128. The vacuum switch 126 is used to sense when the additive pouch 122 is empty, the vacuum switch activates a signal that is sent back to the main control board 20 which returns a signal to stop operation of the respective pump 36 attached to the empty additive pouch 122. A signal is also sent to the user via the control board 20 and a flashing light or message is produced on a display screen 17, informing the operator that the pouch is empty. It is important to note that the vacuum switch is a means of detecting if the pouch is empty and relaying that fact to the user. This represents one means to accomplish this objective other means are plausible. Installed inline with the additive line 134 are an adjustable valve 130 which can be used to regulate flow and a check valve 132 which maintains the system air tight.

[0071] Referring to FIG. 18 and 19, continuing past the check valve 132 the additive line 134 can be constructed according to two different variants.

[0072] Variant 1

[0073] A perspective view of a first variant is depicted in FIG. 15, and the schematic view is depicted in FIG. 18. From the check valve 132, the liquid additive line 134 continues through the machines chassis at 144 and is connected to the dispense tip 92, shown in FIG. 18. As is evident in FIG. 15 only the components required for one liquid additive have been shown for simplicity. A portion of the additive compartment side wall 138 has been removed in order to view the cradle 120 housing the additive pouch 122. Normally, the additive system will be made up a multiple additive pouches 122, cradles 120, additive lines 134, pumps 128, check valves 132 etc. The multiple additive lines 134 will be connected to an equal number of inlet ports 93 on the dispense tip 92 as shown in FIGS. 5 through 10 and FIG. 18. Therefore, each liquid flavour additive is injected into one main base beverage stream. Due to the nature of the design, the scenario depicted in variant prevents any cross contamination of liquid additives.

[0074] Variant 1

[0075] A perspective view of a second variant is depicted in FIG. 16, and the schematic view is depicted in FIG. 19. From the check valve 132, the liquid additive line 134 outlet is connected to an additive manifold 136 through which manifold the hot water supply passes. The manifold is designed with multiple inlet ports 152 equal to the number

of liquid additive lines 134. The manifold 136 is installed inline with the hot water supply line 54 as shown in FIGS. 16 and 17. Each of the inlet ports 152 is in communication with the water supply line 54.

[0076] In operation the first variant functions as follows: The user depresses the appropriate switch(es) 82 on the keypad on the front door of the apparatus, selecting the beverage type they desire. The control 20 activates the solenoid valve 52, which expels water from the hot water boiler 42 through the hot water supply line 54. The control board also activates the auger motor 16, which expels powder from the hopper 12 into the mixing system 34, 32, 30. The water and powder is expelled at a pre-determined rate pre-programmed into the control 20. The water and powder could be expelled for a predetermined amount of time other wise known as PORTION CONTROL, but not necessarily. The alternative is known as FREE FLOW or PUSH AND HOLD, which means that as long as the button is depressed water and powder are being expelled. (These represent functions involved in the production of the BASE hot beverage). In the case of variant one under a PORTION CONTROL set up, based on the push button depressed the respective liquid additive system is activated by the control 20. The liquid additive from the pouch 122 is injected into the stream of mixed hot powder beverage via the dispense tip 92. It is injected at a predetermined time during the base hot beverage production cycle, in order to increase the mixing and eliminate the possibility of cross contamination. In the instance when PUSH and HOLD is implemented the liquid additive is PULSED into the base hot beverage stream at dispenser tip 92 in order to attain the proper mix. For example, at a minimum an 8 oz beverage is produced, we can further reduce the beverage production down to one finished ounce of hot beverage which consists of powder, water and liquid additive. Since the base beverage flow rate is predetermined we can inject the required additive for one ounce of finished product. Therefore, if the flow rate is 1 oz/second for every second that the user depresses the button, the system will inject a proportional number of ml's of liquid additive into the stream of hot water. Due to the fact the ratio of hot water to liquid additive is very high approximately 58-1 the time to inject the additive will be milliseconds, as a result the additional hot water running through the lines after the liquid additive reduces the risk of cross contamination. Since the apparatus provides one main base hot beverage line and a plurality of liquid additives it is important to eliminate cross contamination of liquid additive, in this scenario it is accomplished.

[0077] In operation the second variant functions as follows: The user depresses the appropriate switch(es) on the keypad on the front door of the apparatus, selecting the beverage type they desire. The control 20 activates the solenoid valve 52 which expels water from the hot water boiler 42 through the hot water supply line 54. The control board also activates the auger motor 16 which expels powder from the hopper 12 into the mixing system 34, 32, 30. The water and powder is expelled at a pre-determined rate pre-programmed into the control 20. The water and powder could be expelled for a predetermined amount of time other wise known as PORTION CONTROL, but not necessarily. The alternative is known as FREE FLOW or PUSH AND HOLD, which means that as long as the button is depressed water and powder are being expelled. (These represent functions involved in the production of the BASE hot

beverage). In the case of variant two under a PORTION CONTROL set up, based on the push button depressed the respective liquid additive system is activated by the control 20. The liquid additive from the pouch 122 is injected through the liquid additive manifold 136 into the stream of hot water flowing through the hot water supply line 54. It is injected at a predetermined time during the base hot beverage production cycle, in order to increase the mixing and eliminate the possibility of cross contamination. In the instance when PUSH and HOLD is implemented the liquid additive is PULSED into the hot water stream at additive manifold 136 in order to attain the proper mix. For example, at a minimum an 8 oz beverage is produced, we can further reduce the beverage production down to one finished ounce of hot beverage which consists of powder, water and liquid additive. Since the base beverage flow rate is predetermined we can inject the required additive for one ounce of finished product. Therefore, if the flow rate is 1 oz/second every second that the user depresses the button, the system will inject a proportional number of ml's of liquid additive into the stream of hot water. Due to the fact the ratio of hot water to liquid additive is very high, approximately 58-1, the time to inject the additive will be milliseconds as a result the additional hot water running through the lines after the liquid additive reduces the risk of cross contamination. Since the apparatus provides one main base hot beverage line and a plurality of liquid additives it is important to eliminate cross contamination of liquid additive, in this scenario it is accomplished.

[0078] Now that the invention has been described numerous modifications, substitutions and equivalents will occur to those skilled in the art. The scope of the invention is not to be limited by the embodiments disclosed herein but is defined by the claims appended hereto.

I claim:

1. A liquid flavouring syrup connector adapted for use with hot drink dispense apparatus comprising:

- (a) a main body forming a passage connecting an inlet and an outlet;
- (b) means to engage said passage to a drink dispenser apparatus drink dispenser outlet; and
- (c) at least one liquid flavouring supply port formed in said main body in communication with said passage, whereby flavouring syrup supplied to said liquid supply port will flow into said passage.

2. The apparatus of claim 1 wherein said means to engage said inlet to said drink dispenser apparatus drink dispenser outlet comprises dimensioning said inlet to fictionally engage said drink dispenser apparatus drink dispenser outlet.

3. The apparatus of claim 1 wherein said main body is elongate and generally tubular.

4. The apparatus of claim 1 wherein a hollow stem extends from said main body further forming each said liquid supply port.

5. The apparatus of claim 4 wherein said stem is generally tubular and dimensioned to frictionally engage an inner diameter of a liquid flavour supply line.

6. The apparatus of claim 1 wherein each said liquid flavouring supply port is spacedly disposed from another around the main body.

7. The apparatus of claim 1 wherein each said liquid flavouring supply port has an outlet proximal to the other in the central area of the passage.

8. A liquid flavouring syrup connector adapted for use with hot drink dispense apparatus comprising:

- (a) a main body forming a passage connecting an inlet and an outlet;
- (b) means to engage said passage to a drink dispenser apparatus drink dispenser outlet; and
- (c) at least one stem extending from said main body and forming a liquid flavouring supply port having a port inlet exterior to said main body and a port outlet proximal to the outlet of the passage formed by said main body, whereby flavouring syrup supplied to an inlet of said liquid supply port admix with a fluid discharging from the outlet of said passage.

9. The apparatus of claim 8 wherein said means to engage said passage to said drink dispenser apparatus drink dispenser outlet comprises dimensioning said main body to fictionally engage said drink dispenser apparatus drink dispenser outlet.

10. The apparatus of claim 8 wherein said main body is elongate and generally tubular.

11. The apparatus of claim 8 wherein a hollow stem extends from said main body further forming each said liquid supply port.

12. The apparatus of claim 11 wherein said stem is generally tubular and dimensioned to frictionally engage an inner diameter of a liquid flavour supply line.

13. The apparatus of claim 8 wherein each said liquid flavouring supply port is spacedly disposed from another around the main body.

14. The apparatus of claim 8 wherein each said liquid flavouring supply port has an outlet proximal to the other in the central area of the passage.

15. A method of producing a flavoured hot drink comprising the steps of:

- (a) receiving a drink selection;
- (b) producing a flavoured hot drink supply by performing the steps of:
  - (i) supplying a base powder at a predetermined rate;
  - (ii) supplying hot water at a corresponding rate;
  - (iii) supplying a hot drink flavouring to the hot water supply at a predetermined rate to produce an intermediate hot drink supply;
  - (iv) admixing said base powder with said intermediate hot drink supply to produce a flavoured hot drink supply; and
- (c) continuing said production of said flavoured hot drink supply until the volume produced corresponds to said received drink selection.

**16.** The method of claim 15 wherein said hot drink selection is indicated by user manipulation of one of a plurality of keys on a key pad.

**17.** The method of claim 15 wherein the production of said flavoured hot drink supply is continued only during the time when said received drink selection is being received whereby a push and hold production of said flavoured hot drink supply is effected.

**18.** The method of claim 15 wherein the production of said flavoured hot drink supply is continued from the time when said received drink selection is being received until a predetermined supply is provided whereby a portion controlled production of said flavoured hot drink supply is effected.

\* \* \* \* \*