

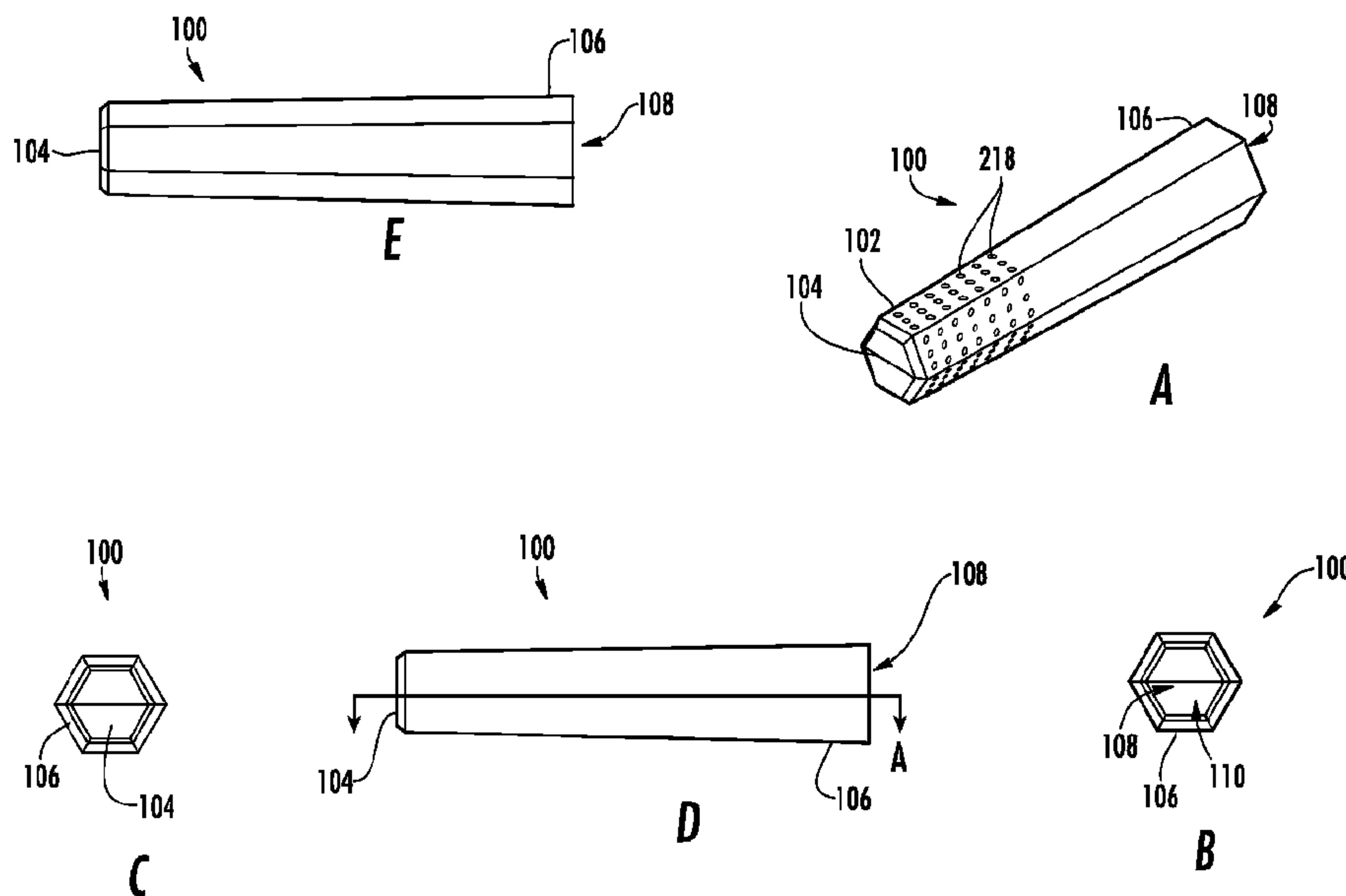

(86) Date de dépôt PCT/PCT Filing Date: 2011/09/13
 (87) Date publication PCT/PCT Publication Date: 2012/03/22
 (45) Date de délivrance/Issue Date: 2018/07/31
 (85) Entrée phase nationale/National Entry: 2013/02/26
 (86) N° demande PCT/PCT Application No.: US 2011/051349
 (87) N° publication PCT/PCT Publication No.: 2012/037089
 (30) Priorité/Priority: 2010/09/13 (US12/880,804)

(51) Cl.Int./Int.Cl. *E02D 7/30* (2006.01),
E02D 3/08 (2006.01), *E02D 7/00* (2006.01)
 (72) Inventeur/Inventor:
WHITE, DAVID J., US
 (73) Propriétaire/Owner:
GEOPIER FOUNDATION COMPANY, INC., US
 (74) Agent: OSLER, HOSKIN & HARCOURT LLP

(54) Titre : COQUES EXTENSIBLES ET PROCEDES ASSOCIES POUR LA CONSTRUCTION D'UN PILIER PORTEUR
 (54) Title: EXTENSIBLE SHELLS AND RELATED METHODS FOR CONSTRUCTING A SUPPORT PIER



(57) **Abrégé/Abstract:**

Extensible shells and related methods for constructing a support pier are disclosed. A shell can define an interior for holding granular construction material and define an opening for receiving the granular construction material into the interior. The shell can be flexible such that the shell expands when granular construction material is compacted in the interior of the shell. A method may include positioning the shell in the ground and filling at least a portion of the interior of the shell with the granular construction material. The granular construction material may be compacted in the interior of the shell to form a support pier.

(12) INTERNATIONAL APPLICATION PUBLISHED UNDER THE PATENT COOPERATION TREATY (PCT)

(19) World Intellectual Property
Organization
International Bureau(10) International Publication Number
WO 2012/037089 A3(43) International Publication Date
22 March 2012 (22.03.2012)

(51) International Patent Classification:

E02D 7/30 (2006.01) E02D 3/08 (2006.01)
E02D 7/00 (2006.01)

(21) International Application Number:

PCT/US2011/051349

(22) International Filing Date:

13 September 2011 (13.09.2011)

(25) Filing Language:

English

(26) Publication Language:

English

(30) Priority Data:

12/880,804 13 September 2010 (13.09.2010) US

(71) Applicant (for all designated States except US): **GEOPI-
ER FOUNDATION COMPANY, INC.**; 150 Fairview
Road, Suite 335, Mooresville, North Carolina 28117 (US).

(72) Inventor; and

(75) Inventor/Applicant (for US only): **WHITE, David J.**
[US/US]; 607 V Avenue, Boone, Iowa 50036 (US).(74) Agent: **MILLS, E. Eric**; Ward and Smith, P.A., P.O. Box
867, 1001 College Court, Post Office Box 867, New Bern,
North Carolina 28563-0867 (US).(81) Designated States (unless otherwise indicated, for every
kind of national protection available): AE, AG, AL, AM,
AO, AT, AU, AZ, BA, BB, BG, BH, BR, BW, BY, BZ,CA, CH, CL, CN, CO, CR, CU, CZ, DE, DK, DM, DO,
DZ, EC, EE, EG, ES, FI, GB, GD, GE, GH, GM, GT, HN,
HR, HU, ID, IL, IN, IS, JP, KE, KG, KM, KN, KP, KR,
KZ, LA, LC, LK, LR, LS, LT, LU, LY, MA, MD, ME,
MG, MK, MN, MW, MX, MY, MZ, NA, NG, NI, NO, NZ,
OM, PE, PG, PH, PL, PT, QA, RO, RS, RU, RW, SC, SD,
SE, SG, SK, SL, SM, ST, SV, SY, TH, TJ, TM, TN, TR,
TT, TZ, UA, UG, US, UZ, VC, VN, ZA, ZM, ZW.(84) Designated States (unless otherwise indicated, for every
kind of regional protection available): ARIPO (BW, GH,
GM, KE, LR, LS, MW, MZ, NA, SD, SL, SZ, TZ, UG,
ZM, ZW), Eurasian (AM, AZ, BY, KG, KZ, MD, RU, TJ,
TM), European (AL, AT, BE, BG, CH, CY, CZ, DE, DK,
EE, ES, FI, FR, GB, GR, HR, HU, IE, IS, IT, LT, LU, LV,
MC, MK, MT, NL, NO, PL, PT, RO, RS, SE, SI, SK, SM,
TR), OAPI (BF, BJ, CF, CG, CI, CM, GA, GN, GQ, GW,
ML, MR, NE, SN, TD, TG).

Published:

- with international search report (Art. 21(3))
- before the expiration of the time limit for amending the
claims and to be republished in the event of receipt of
amendments (Rule 48.2(h))

(88) Date of publication of the international search report:

14 June 2012

(54) Title: EXTENSIBLE SHELLS AND RELATED METHODS FOR CONSTRUCTING A SUPPORT PIER

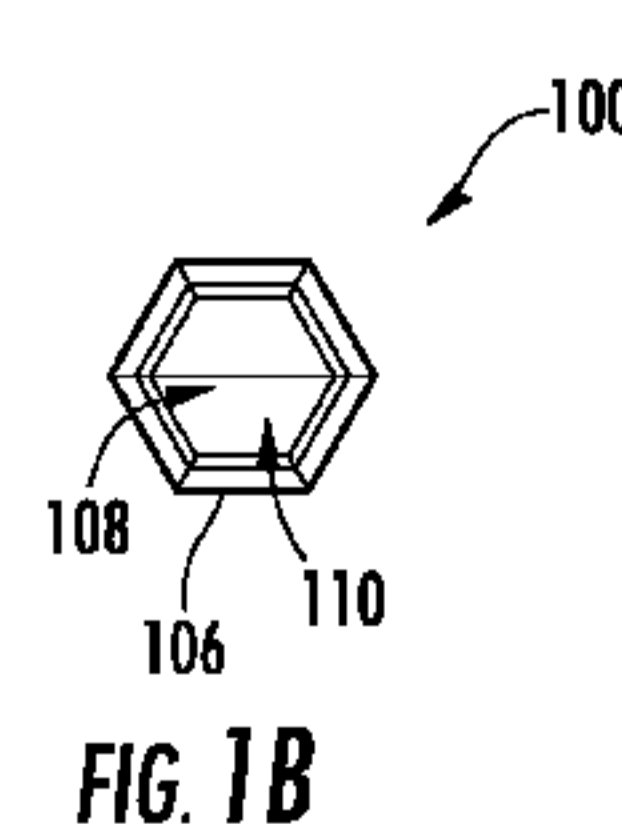
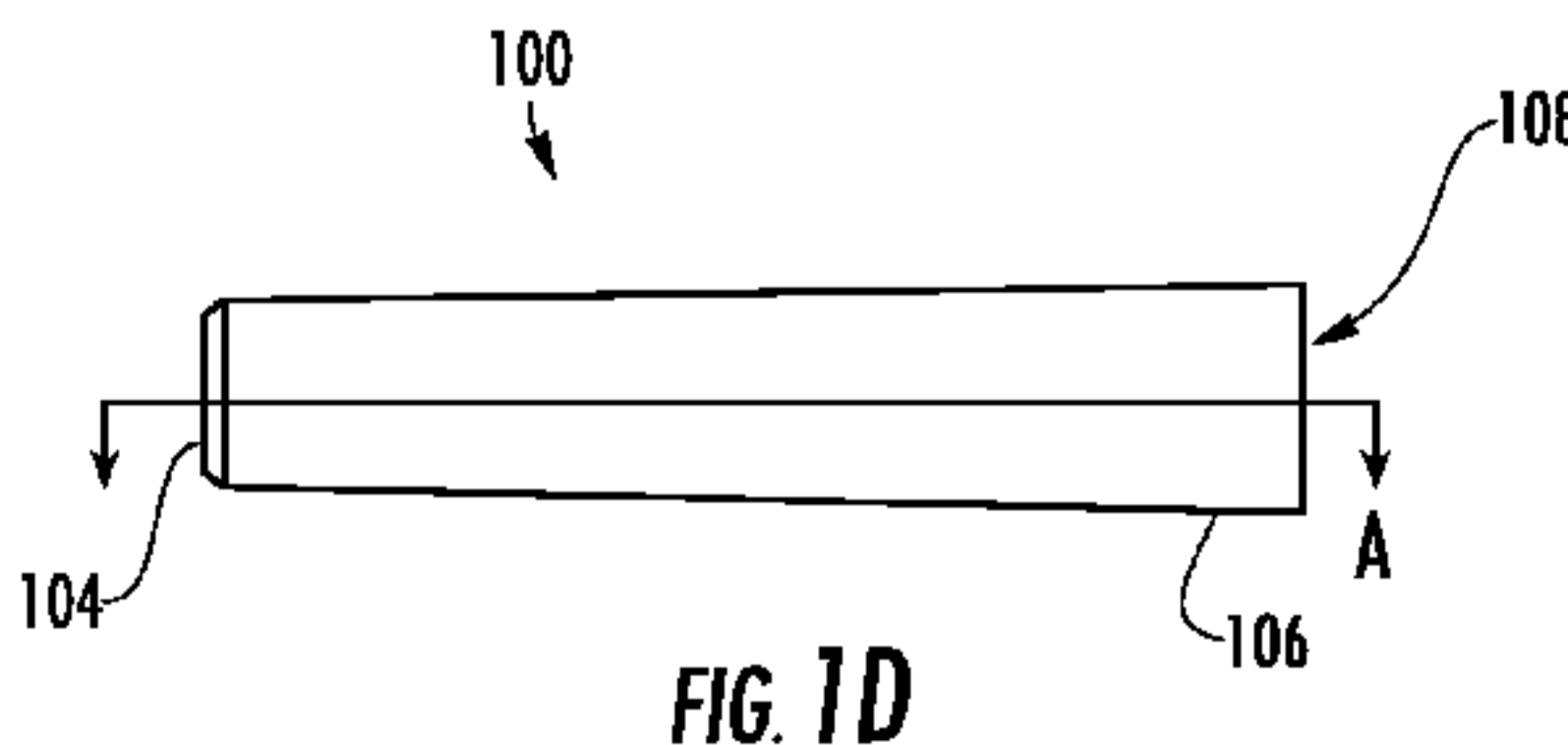
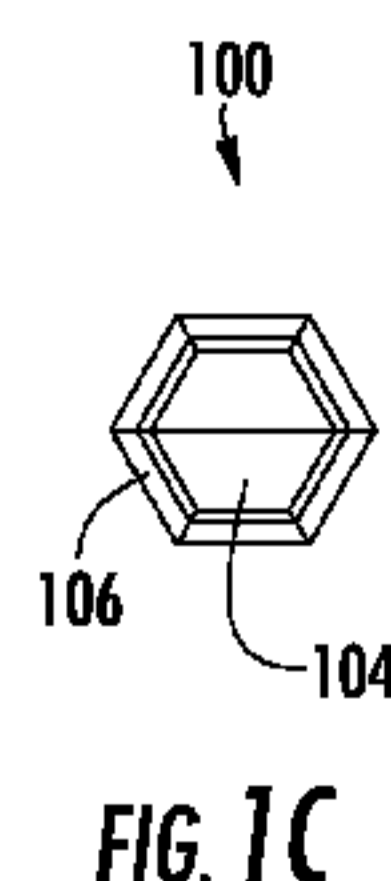
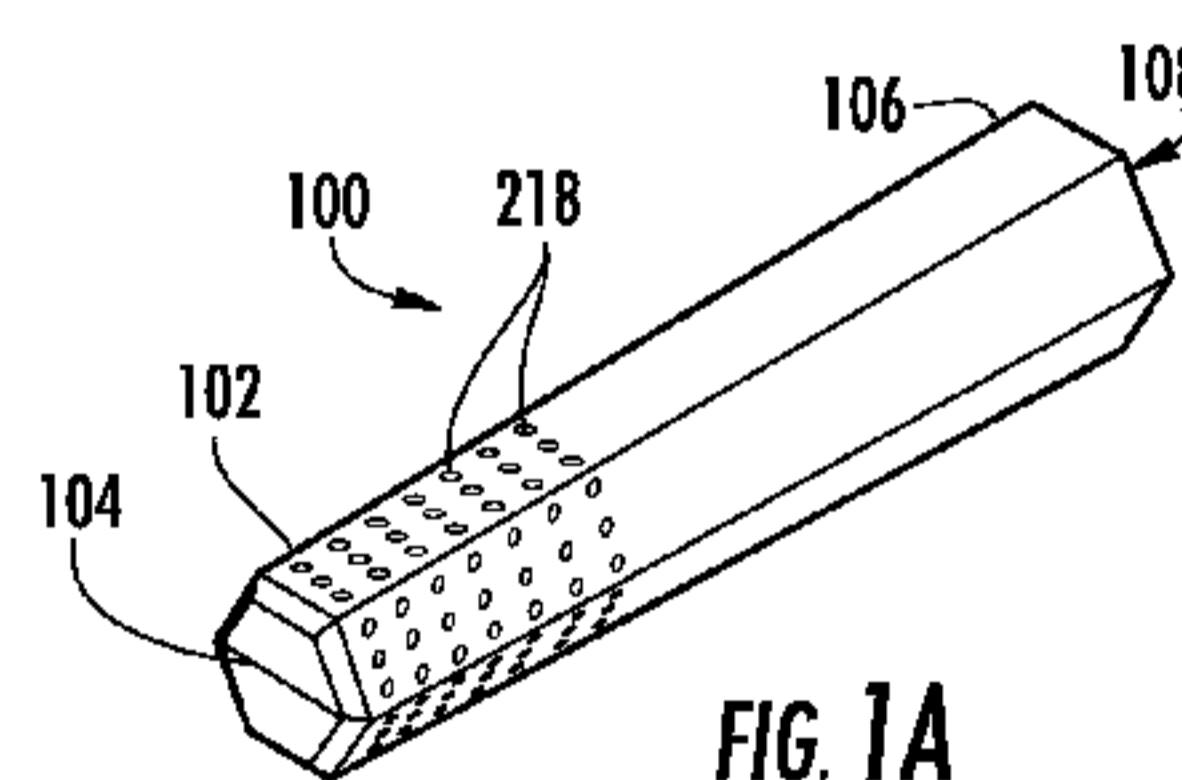
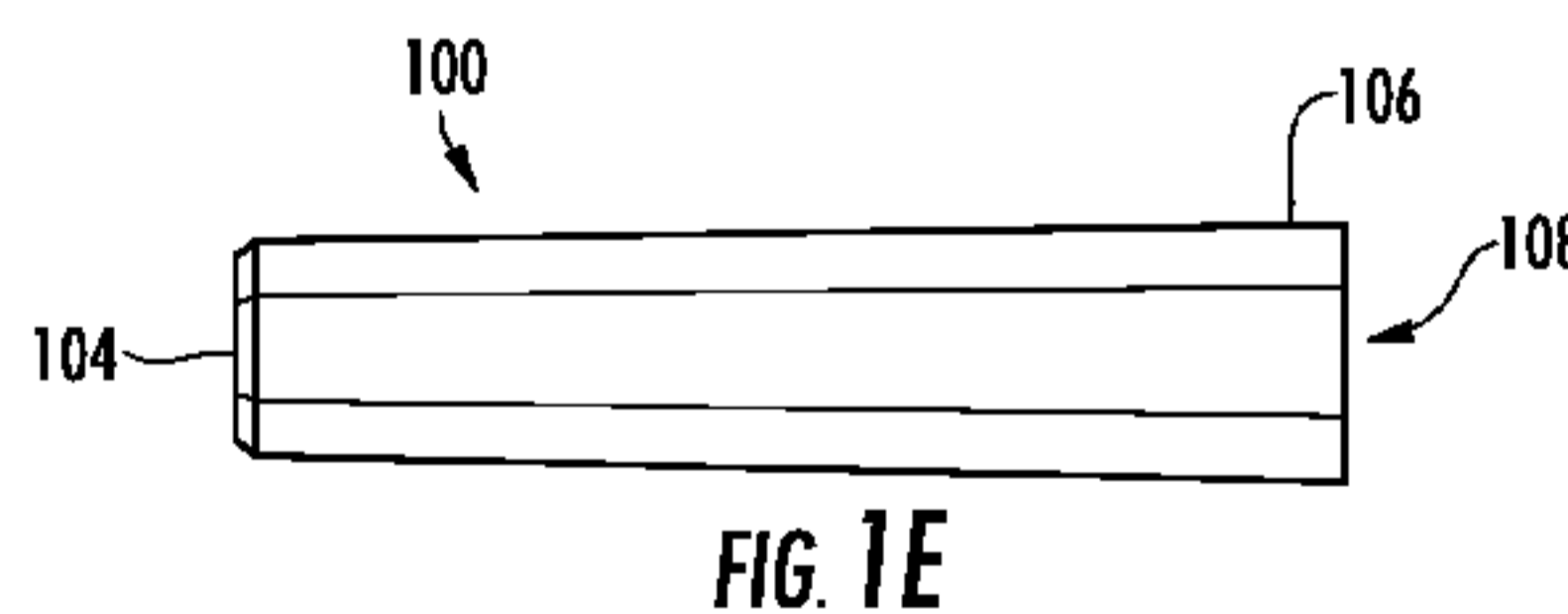

(57) Abstract: Extensible shells and related methods for constructing a support pier are disclosed. A shell can define an interior for holding granular construction material and define an opening for receiving the granular construction material into the interior. The shell can be flexible such that the shell expands when granular construction material is compacted in the interior of the shell. A method may include positioning the shell in the ground and filling at least a portion of the interior of the shell with the granular construction material. The granular construction material may be compacted in the interior of the shell to form a support pier.



WO 2012/037089 A3

**EXTENSIBLE SHELLS AND RELATED METHODS FOR
CONSTRUCTING A SUPPORT PIER**

TECHNICAL FIELD

[0001] The present invention relates to ground or soil improvement apparatuses and methods.

[0002] More specifically, the present invention relates to extensible shells and related methods for constructing a support pier.

BACKGROUND ART

[0003] Buildings, walls, industrial facilities, and transportation-related structures typically consist of shallow foundations, such as spread footings, or deep foundations, such as driven pilings or drilled shafts. Shallow foundations are much less costly to construct than deep foundations. Thus, deep foundations are generally used only if shallow foundations cannot provide adequate bearing capacity to support building weight with tolerable settlements.

[0004] Recently, ground improvement techniques such as jet grouting, soil mixing, stone columns, and aggregate columns have been used to improve soil sufficiently to allow for the use of shallow foundations. Cement-based systems such as grouting or mixing methods can carry heavy loads but remain relatively costly. Stone columns and aggregate columns are generally more cost effective but can be limited by the load bearing capacity of the columns in soft clay soil.

[0005] Additionally, it is known in the art to use metal shells for the driving and forming of concrete piles. One set of examples includes U.S. Patent Nos. 3,316,722 and 3,327,483 to Gibbons, which disclose the driving of a tapered, tubular metal shell into the ground and subsequent filling of the shell with concrete in order to form a pile. Another example is U.S. Patent No. 3,027,724 to Smith which discloses the installation of shells in the earth for subsequent filling with concrete for the forming of a concrete pile. A disadvantage of these prior art shells is that their sole purpose is for

providing a temporary form for the insertion of cementitious material for the forming of a hardened pile for structural load support. The prior art shells are not extensible and thus do not exhibit properties that allow them to engage the surrounding soil through lateral deformations. Further, because they relate to the use of ferrous materials, which are subject to corrosion, their function is complete once the concrete infill hardens. Thus, the prior art shells are not suitable for containing less expensive granular infill materials such as sand or aggregate, because the prior art shells cannot laterally contain the inserted materials during the life of the pier. The prior art shells are also not permeable and are thus ill-suited to drain cohesive soils.

[0006] Accordingly, it is desirable to provide improved techniques for constructing a shallow support pier in soil or the ground using extensible shells formed of relatively permanent material of a substantially non-corrosive or non-degradable nature for the containment of compacted aggregate therein.

BRIEF DESCRIPTION OF THE INVENTION

[0007] Extensible shells and related methods for constructing a support pier in ground are disclosed. An extensible shell may define an interior for holding granular construction material and may define an opening for receiving the granular construction material into the interior. The shell may be flexible such that the shell expands laterally outward when granular construction material is compacted in the interior of the shell.

[0008] According to one aspect, the shell may include a first end that defines the opening. The shell may be shaped to taper downward from the first end to an opposing second end of the shell.

[0009] According to another aspect, the second end of the shell may define a substantially flat, blunt surface.

[0010] According to yet another aspect, a cross-section of the shell may form one of a substantially hexagonal shape and a substantially octagonal shape along a length of the shell extending between the first and second ends.

[0011] According to a further aspect, a cross-section of the first end of the shell is sized larger than a cross-section of the second end.

[0012] According to a still further aspect, the shell is comprised of plastic.

[0013] According to another aspect, the shell may define a plurality of apertures extending

between an interior of the shell to an exterior of the shell.

[0014] According to yet another aspect, the shell may be either substantially cylindrical in shape or substantially conical in shape.

[0015] According to an additional aspect, a method may include positioning the shell in the ground and filling at least a portion of the interior of the shell with the granular construction material. The granular construction material may be compacted in the interior of the shell to form a pier.

[0016] According to another aspect, a method may include forming a cavity in the ground. The cavity may be partially backfilled with aggregate construction material. Next, the shell may be positioned with the cavity and at least a portion of the interior of the shell filled with granular construction material. The granular construction material may then be compacted in the interior of the shell to form a pier. The compaction may be performed with a primary mandrel. Additional compacting may be performed with a second mandrel that has a larger cross-sectional area than the primary mandrel.

[0017] According to a further aspect, the extensible shell may comprise a plurality of slots extending between an interior of the shell to an exterior of the shell, the slots being generally transverse to a centerline along the length of the shell. The slots may be discontinuous around a circumference of the shell thereby maintaining portions of continuous material connectivity along the length of the shell. The slots may have a width in the range of 1/4 inch (6.35 mm) to 3/8 inch (9.53 mm) and may be spaced at a distance of 6 inches (152 mm) from one another.

[0018] This brief description of the invention is provided to introduce a selection of concepts in a simplified form that are further described below in the detailed description of the invention. This brief description of the invention is not intended to identify key features or essential features of the claimed subject matter, nor is it intended to be used to limit the scope of the claimed subject matter. Further, the claimed subject matter is not limited to implementations that solve any or all disadvantages noted in any part of this disclosure.

BRIEF DESCRIPTION OF THE DRAWINGS

[0019] Figures 1A - 1E illustrate different views of an extensible shell in accordance with embodiments of the present invention;

[0020] Figures 2A - 2C illustrate steps in an exemplary method of constructing a pier in

ground using an extensible shell in accordance with an embodiment of the present invention;

[0021] Figures 3A - 3D illustrate steps in another exemplary method of constructing a support pier in ground using an extensible shell in accordance with embodiments of the present invention;

[0022] Figures 4 - 7 are graphs showing results of load tests of support piers constructed using an extensible shell in accordance with embodiments of the present invention;

[0023] Figure 8 illustrates a perspective view of another embodiment of the present invention pertaining to a slotted shell; and

[0024] Figure 9 is a graph showing results of load tests of a support pier constructed with an embodiment as shown in Figure 8.

DETAILED DESCRIPTION OF THE INVENTION

[0025] The present invention is directed to an extensible shell and related methods for constructing a support "shell pier" in ground. Particularly, an extensible shell in accordance with embodiments of the present invention can have an interior into which granular construction material can be loaded and compacted. The shell can be positioned in a cavity formed in the ground (the cavity being formed through a variety of methods as described in more detail below, including driving the shell from grade to form the cavity). After positioning in the ground, granular construction material can be loaded into the interior through an opening of the shell. The granular construction material may be subsequently compacted. The shell can be extensible (or flexible) such that walls of the shell expand when the granular construction material is compacted in the interior of the shell. Therefore, since the shell maintains the compacted granular construction material in a contained manner (i.e., the material cannot expand laterally beyond the shell walls into the in-situ soil) the ground surrounding the shell is reinforced and improved for supporting shallow foundations and other structures. The present invention can be advantageous, for example, because it allows for much higher load carrying capacity due to its ability to limit the granular construction material from bulging laterally outward during loading. The shell is typically made of relatively permanent, substantially non-corrosive and/or non-degradable material such that the lateral bulging of the material is limited for the life of the pier.

[0026] Figures 1A - 1E illustrate different views of an extensible shell 100 in accordance with embodiments of the present invention. Figure 1A depicts a perspective view of the extensible

shell 100, which includes an enclosed end 102. The surface of the enclosed end 102 can define a substantially flat, blunt bottom surface 104, which can be hexagonal in shape. In the alternative, the enclosed end 102 may have any other suitable shape or size. Further, the bottom of the shell may be open, or may be blunt as in the case of a cylindrical shell, may be pointed as the bottom of a conical shell, or may be truncated to form a blunt shape at the bottom of conical or articulated section. The length of the shell may range from about 0.5 m to about 20 m long; such as from about 1 m to about 10 m long. The surfaces of the shell (inside and/or outside) may be smooth or contain a varying degree of roughness for interaction with surrounding surfaces.

[0027] Opposing the enclosed end 102 is another end, open end 106, which defines an opening 108 for receiving granular construction material into an interior (not shown in Figure 1A) defined by the shell 100. As will be described in further detail herein below, the open end 106 is positioned substantial vertical to and above from the enclosed end 102 during construction of the pier.

[0028] Figures 1B, 1C, 1D, and 1E depict a top view, bottom view, a side view, and a cross-sectional side view of the extensible shell 100, respectively. As shown in Figure 1B, the extensible shell 100 defines a substantially hollow interior 110 extending between the open end 106 (with opening 108) and the enclosed end 102.

[0029] Figure 1C shows that a cross-section of the open end 106 may be sized larger than the bottom surface 104 of the enclosed end 102. Figure 1D shows section line A-A arrows indicating the direction of the cross-sectional side view of the extensible shell 100 depicted in Figure 1E.

[0030] The shape of the exterior of the shell 100 may be articulated to form a plurality of panels that form a hexagonal shape in cross-section as viewed from the top or bottom of the shell. Alternatively, the shape may be octagonal, cylindrical, conical, or any other suitable shape.

[0031] The extensible shell 100 is often shaped to taper downward from the open end 106 to the enclosed end 102. In one embodiment, the shell 100 tapers at a 2 degree angle, although the shell may taper at any other suitable angle.

[0032] The extensible shell 100 may be made of plastic, aluminum, or any metallic or non-metallic material of suitable extensibility, and preferably substantially non-corrosive and/or non-degradable material. The shell 100 may be relatively thin-walled. The thickness of the wall of the shell 100 may range, for example, from about 0.5 mm to about 100 mm. The example shell 100 of Figure 1B has a thickness of about 0.25 inches (approximately 6.35 mm), although the shell may have

any other suitable thickness. This thickness distance is the distance that uniformly separates the interior 110 and the exterior of the shell. The material of the shell and its thickness may be configured such that the shell has suitable integrity to hold construction material in its interior 110 and to expand laterally at least some distance when the construction material is compacted in the interior 110.

[0033] Figures 2A - 2C illustrate steps in an exemplary method of constructing a pier in ground using an extensible shell 100 in accordance with an embodiment of the present invention. In this example, side partial cross-section views illustrate the use of the extensible shell 100 for constructing a pier 200 in the ground (see Figure 2C) in accordance with an embodiment of the present invention. Other methods are described with reference to Figures 3A - 3D and the Examples below. The method of Figures 2A - 2C includes forming a pre-formed elongate vertical cavity 202 or hole in a ground surface 204, as shown in Figure 2A. The ground may be comprised of primarily soft cohesive soil such as soft clay and silt, or also loose sand, fill materials, or the like. The cavity 202 may be formed with a suitable drilling device having, for example, a drill head or auger for forming a cavity or hole, or may be formed by other methods for forming a cavity such as by inserting and removing a driving mandrel to the desired pre-formed cavity depth. In some embodiments, the cavity may not be formed at all prior to shell insertion, such as described below with reference to Figures 3A - 3D.

[0034] After the partial cavity 202 has been formed, the extensible shell 100 may be positioned within the cavity 202, as shown in Figure 2B, for ultimate driving to the desired depth. Particularly, an extractable mandrel 206 may be used for driving the extensible shell 100 into the cavity 202 and ground 204. A tamper head 208 of the mandrel 206 may be positioned against a bottom surface 210 of the interior 110 and used to drive the shell 100 to the desired penetration depth, as shown in Figure 2C. The cavity 202 is at that point formed of a size and dimension such that the exterior surface of the extensible shell 100 fits tightly against the walls of the cavity 202.

[0035] After the extensible shell 100 has been driven into (while forming) the fully enlarged cavity 202, the mandrel 206 is removed, leaving behind the shell 100 in the cavity 202 and with the interior 110 being empty. The shell 100 may then be filled with a granular construction material 212, such as sand, aggregate, admixture-stabilized sand or aggregate, recycled materials, crushed glass, or other suitable materials as shown in Figure 2C. The granular construction material 212 may be compacted within the shell using the mandrel 206. The compaction increases the strength and stiffness of the internal granular construction material 212 and pushes the granular construction

material 212 outward against the walls of the shell 100, which pre-strains the shell 100 and increases the coupling of the shell 100 with the in-situ soil. Significant increases in the load carrying capacity of the pier 200 can be achieved as a result of the restraint offered by the shell 100.

[0036] Figures 3A - 3D illustrate steps in another exemplary method of constructing a pier in ground using an extensible shell in accordance with an embodiment of the present invention. Referring to Figure 3A, an aggregate construction material 300 (e.g., sand) is placed in the interior 110 of the shell 100 to a predetermined level above the bottom surface 210 of the shell 100. Next, the tamper head 208 of the extractable mandrel 206 is fitted to the interior 110 of the extensible shell 100, and against the top of the aggregate construction material 300. The mandrel 206 may then be moved towards the ground 204 in a direction indicated by arrow 302 for driving the shell 100 into the ground 204. Driving may be facilitated using a small pre-formed cavity (e.g., the cavity 202 shown in Figure 2A), or not, depending on site conditions.

[0037] Referring to Figure 3B, the mandrel 206 is shown driving the shell 100 into the ground 204 in the direction 302 such that the shell 100 is at a predetermined depth below grade. Next, the mandrel 206 may be removed. At Figure 3C, the shell 100 is substantially filled with additional aggregate construction material 304 (e.g., sand) through opening 108, and the mandrel 206 is positioned as shown. Next, vertical compaction force and/or vibratory energy is applied to the mandrel 206 for compacting the materials 300 and 304. The shell 100 may be driven by this force to a further depth below grade. The addition of construction material 304 and subsequent compaction can be repeated several times until the final pier is constructed. Alternatively, the shell may be "topped off" with additional construction material after only one compaction cycle.

[0038] In an embodiment of the present invention, a second mandrel 212 may be used to compact the upper portion of the material 304 in the direction 302, as shown in Figure 3D. The second mandrel 212 may have a larger cross-sectional area than the primary mandrel 206 to provide increased confinement during compaction.

[0039] In an embodiment of the present invention, the shell 100 may define apertures 218 that extend between the interior 110 and an exterior of the shell 100 to the in-situ soil (see Figures 1A and 2C). The apertures 218 may provide for drainage of excess pore water pressure that may exist in the in-situ soil to drain into the interior 110 of the shell 100. Increases in pore water pressure typically decreases the strength of the soil and is one of the reasons that prior art piers are limited in their load

carrying capacity in saturated cohesive soil such as clay, silt, or the like. The apertures 218 envisioned herein allow the excess pore water pressure in the soil to dissipate into the pier 200 after insertion. This allows the in-situ soil to quickly gain strength with time, a phenomena not enjoyed by concrete, steel piles, or grout elements (i.e., "hardened" elements). The drainage of excess pore water pressures allows additional settlement of the soil that may occur as a result of pore water pressure dissipation prior to the application of foundation loads.

[0040] Other embodiments may not define apertures, or may provide one or more apertures 218 on only one side of the shell 100. Alternatively, the apertures 218 may be defined in the shell 100 such that they are positioned along a portion of the length of the shell 100, are positioned along the full length of the shell 100, or may be positioned asymmetrically in various configurations. The sizes and placements of the apertures 218 can vary according to the size of the shell 100, the conditions of the ground (e.g., where higher water pressure is known to exist), and other relevant factors. The apertures 218 may range in size from about 0.5 mm to about 50 mm; such as from about 1 mm to about 25 mm. In another embodiment, the top of the shell 100 may be enclosed and connected to vacuum pressure to further increase and accelerate drainage of excess water pressure in the surrounding soil through the apertures 218.

[0041] The mandrel 206 may be constructed of sufficient strength, stiffness, and geometry to adequately support the shell 100 during driving and to be able to be retracted from the shell 100 after driving. In one embodiment, the shape of the exterior of mandrel 206 is substantially similar to the shape of the interior 110 defined by the shell 100. In another embodiment, the mandrel 206 is comprised primarily of steel. Other materials are also envisioned including, but not limited to, aluminum, hard composite materials, and the like.

[0042] The mandrel 206 may be driven by a piling machine or other suitable equipment and technique that may apply static crowd pressure, hammering, or vibration sufficient to drive the mandrel 206 and extensible shell 100 into the surface of ground 204. In one embodiment, the machine may be comprised of an articulating, diesel, pile-driving hammer that drives the mandrel 206 using high energy impact forces. The hammer may be mounted on leads suspended from a crane. In another embodiment, the hammer may be a sheet pile vibrator mounted on a rig capable of supplying a downward static force. In another embodiment, the shell 100 may be placed in a pre-formed cavity 200 and constructed without the use of an extractable mandrel. Standard methods of driving mandrels

into the ground are known in the art and therefore, can be used for driving.

[0043] The following Examples illustrate further aspects of the invention.

Example I

[0044] As an example, piers were constructed using extensible shells in accordance with embodiments of the present invention at a test site in Iowa. Load tests were conducted on the piers using a conventional process. The extensible shells used in the tests and the methods of their use consisted essentially of that described above and shown in the attached Figures. In this test, extensible shells formed from LEXAN[®] polycarbonate plastic were installed at a test site characterized by soft clay soil. This testing was designed to compare the load versus deflection characteristics of an extensible shell in accordance with the present invention to aggregate piers constructed with a driven tapered pipe. Two comparison aggregate piers (of fine and coarse aggregate) were constructed to a depth of 12 feet below the ground surface.

[0045] In this test, the extensible shell was formed by bending sheets of the plastic to form a tapered shape having a hexagonal cross-section and that tapered downward from an outside diameter of 24 inches (610 mm) at the top of the shell to a diameter of 18 inches (460 mm) at the bottom of the shell. A panel of the shells overlapped, and this portion was both glued and bolted together. The length of the extensible shell was 9.5 feet (2.9 m). In this embodiment, apertures were formed in the extensible shell by perforating the sides of the shell with 3 mm to 7 mm diameter "weep" holes spaced apart from each another. The bottom portion of the shell was capped with a steel shoe to facilitate driving. LEXAN[®] polycarbonate plastic has a tensile strength of approximately 16 MPa (2300 psi) at 11 percent elongation and a Young's modulus of 540 MPa (78,000 psi). The extractable mandrel used in this test was attached to a high frequency hammer, which is often associated with driving sheet piles. The hammer is capable of providing both downward force and vibratory energy for driving the shell into the ground and for compacting aggregate construction material in the shell.

[0046] In this example, the extensible shell was driven into the ground without pre-drilling of the cavity or hole. Particularly, in this test, the two shells were installed by orientating each shell in a vertical direction, placing approximately 4 feet (1.2 m) of sand at the base of the shell, and then driving the shell into the ground surface with an extractable mandrel with exterior dimensions similar to those of the interior of the shell. The shell was driven to a depth of approximately 8.5 feet (2.6 m)

below grade. The mandrel was removed and the shells were filled with sand. The extractable mandrel was then re-lowered within the shells and vertical compaction force in combination with vibratory energy was applied to both compact the sand to drive the shell to a depth of 9 feet (2.7 m) below grade. The mandrel was then extracted and the upper portion of the shell was then filled with crushed stone to a depth of 0.5 ft (0.2 m) below grade. A concrete cap was then poured above the crushed stone fill to facilitate load testing.

[0047] Radial cracks were observed to extend outward from the edge of the shell pier. These cracks form drainage galleries that are the result of high radial stresses and low tangential stresses created in the ground during pier installation. Drainage was afforded by the perforations in the shell and allowed soil water to drain into the sand and aggregate filled piers.

[0048] The shell piers were load tested using a hydraulic jack pushing against a test frame. Figure 4 is a graph showing results of the load test compared with aggregate piers constructed with a similarly shaped mandrel. As shown in Figure 4, at a top of pier deflection of one inch, the piers constructed without shells supported a load of 15,000 pounds to 20,000 pounds (67 kN to 89 kN). The shell piers constructed in this embodiment of the invention supported a load of 310 kN to 360 kN (70,000 to 80,000 pounds) at a top of pier deflection of one inch. The load carrying capacity of the shell piers constructed in accordance with the present invention provided a 3.5 to 5.3 fold improvement when compared to aggregate piers constructed without extensible shells.

Example II

[0049] In other testing, extensible shells were formed from high-density polyethylene polymer ("HDPE") and installed at the test site as described in Example I. This testing program was designed to compare the load versus deflection characteristics of this embodiment of the present invention to aggregate piers constructed with a driven tapered pipe as described in Example I. A total of six shell piers were installed as part of this example.

[0050] In this test, the extensible shell was formed by a rotomolding process. The shells defined a tapered shape having a hexagonal cross-section and that tapered downward from an outside diameter of 585 mm (23 inches) at the top of the shell to a diameter of 460 mm (18 inches) at the bottom of the shell. The bottom of the extensible shell was integrally constructed as part of the shell walls as a result of the rotomolding process. The mandrel in this embodiment was attached to the same

hammer as described in Example I.

[0051] The installation process in this Example was somewhat different from that in Example I and included pre-drilling a 30 inch (0.76 m) diameter cavity to a depth of 2 feet (0.61 m) to 3 feet (0.9 m) below the ground surface (rather than driving the shell initially from top grade). The shell was then placed vertically in the pre-drilled cavity. The extractable mandrel was then inserted into the shell, and the shell was driven to a depth 11 feet (3.4 m) to 12 feet (3.7 m) below grade. The extensible shell was then filled with aggregate construction material and compacted in four lifts; with each lift about 7.4 cubic feet (0.2 cubic meters) in volume. The aggregate consisted of sand in five of the piers and consisted of crushed stone in one of the piers. Each lift was compacted with the downward pressure and vibratory energy of the extractable mandrel.

[0052] After placement and compaction of sand within the extensible shells, the top of the shells were situated at about 2 feet (0.61 m) to 3 feet (0.9 m) below the ground surface. Crushed stone was then placed and compacted above the extensible shell to a depth of 1 foot (0.3 m) below the ground surface. A concrete cap was then poured above the crushed stone fill to facilitate load testing.

[0053] The shell piers were load tested using a hydraulic jack pushing against a test frame. Figure 5 is a graph showing results of the load test compared with the aggregate piers described in Example I. As shown in Figure 5, at a top of pier deflection of one inch, the piers constructed without shells supported a load of 15,000 pounds to 20,000 pounds (67 kN to 89 kN). The shell piers constructed in this embodiment of the invention supported loads ranging from 62,000 pounds (275 kN) to 71,000 pounds (315 kN) at the top of pier deflections of one inch. The load carrying capacity of the shell piers constructed in accordance with this embodiment of the present invention provided a 3.1 to 4.7 fold improvement when compared to aggregate piers constructed without extensible shells.

Example III

[0054] In another test, an extensible shell of the same embodiment described in Example II was installed at the test site as described in Example I. This testing program was designed to compare the load versus deflection characteristics of this embodiment of the invention to aggregate piers constructed with a driven tapered pipe as described in Example I. The mandrel, hammer, and extensible shell used for testing were the same as used in Example II.

[0055] In this embodiment of the present invention, the installation process included pre-

drilling a 30 inch (0.76 m) diameter cavity to a depth of 3 feet (0.9 m) below the ground surface. The extractable mandrel was then inserted into the pre-drilled cavity, to create a cavity with a total depth of 5 feet (1.5 m) below the ground surface. This cavity was then backfilled to the ground surface with sand. The extensible shell was then driven vertically through the sand filled cavity with the extractable mandrel to a depth of 9 feet (2.7 m) below the ground surface, so that the top of the shell was situated 6 inches above the ground surface. The extensible shell was then filled with sand in four lifts, with each lift about 7.4 cubic feet (0.2 cubic meters) in volume. Each lift was compacted with the downward pressure and vibratory energy of the mandrel. A concrete cap encompassing the top of the shell was then cast over the shell to facilitate load testing.

[0056] The shell pier was load tested using a hydraulic jack pushing against a test frame. Figure 6 is a graph showing results of the load test compared with the aggregate piers described in Example I. As shown in Figure 6, at a top of pier deflection of one inch, the piers constructed without shells supported a load of 15,000 pounds to 20,000 pounds (67 kN to 89 kN). The pier constructed in this embodiment of the present invention supported a load of 57,500 pounds (255 kN) with a top of pier deflection of one inch. The load carrying capacity of the shell pier constructed in accordance with this embodiment of the present invention provided a 2.9 to 3.8 fold improvement when compared to aggregate piers constructed without extensible shells.

Example IV

[0057] In yet another test, an embodiment of the present invention was installed at a project site characterized by 3 feet (0.9 m) of loose sand soil over 7 feet (2.1 m) of soft clay soil over dense sand soil. The embodiment of the present invention at the project site was used to support structural loads, such as those associated with building foundations and heavily loaded floor slabs. The mandrel, hammer, and extensible shell used for testing were the same as used in Examples II and III.

[0058] In this embodiment of the present invention, the installation process included pre-drilling a 30 inch (0.76 m) diameter pre-drill to a depth of 3 feet (0.9 m) below the ground surface. Approximately 7.4 cubic feet (0.2 cubic meters) of sand was then placed in the pre-drilled cavity. This resulted in the pre-drilled cavity being about half-full.

[0059] The extensible shell was then placed vertically in the partially backfilled pre-drilled cavity. The extractable mandrel was then inserted into the shell, and the shell was driven to a depth

12.5 feet (3.8 m) below grade. The extensible shell was then filled with sand in four lifts; with each lift about 7.4 cubic feet (0.2 cubic meters) in volume. Each lift was compacted with the downward pressure and vibratory energy of the mandrel.

[0060] After placement and compaction of sand within the extensible shell, a lift of crushed stone about 4.9 cubic feet (0.14 cubic meters) in volume was placed and compacted within the extensible shell. Crushed stone was then placed and compacted above the extensible shell until the crushed stone backfill was level with the ground surface.

[0061] At one shell location, a 30 inch (0.76 m) diameter concrete cap was placed over the shell to facilitate load testing. At a second shell location, a 6 foot (1.8 m) wide by 6 foot (1.8 m) wide concrete cap was placed over the shell to facilitate loading and to measure the load deflection characteristics of the composite of native matrix soil and extensible shell (to simulate a floor slab).

[0062] The shell piers were load tested using a hydraulic jack pushing against a test frame, with the results of the load testing being shown in Figure 7. The shell pier tested with the 30 inch diameter concrete cap supported a load of 35,500 pounds (158 kN) at a deflection of 0.4 inches (10 mm). The shell pier tested with a 6 foot wide by 6 foot wide concrete cap supported a load of 104,700 pounds (467 kN) at a deflection of 0.4 inches (10 mm).

Slotted Shell Embodiment

[0063] With reference to Figure 8, an alternative embodiment of the present invention is shown and which includes an extensible shell 800 with one or more slits or slots 812 that extend between an interior of the shell to an exterior of the shell. The slots 812 may be placed over the entire length of the shell 800 or only partially located along the length and have varying spacing, such as, for example, slots being spaced every 6 inches (152 mm) starting generally 1.5 foot (0.46 m) from the top and bottom.. The slots 812 may be of varying widths, such as, for example, 1/4 inch (6.35 mm) to 3/8 inch (9.53 mm) wide. The slots 812 typically run generally transverse to a centerline along the length of the shell and may form a minor or major part of the circumference of the shell 800. In one embodiment, such as shown in Figure 8, the slots 812 are discontinuous around the circumference leaving three spines 814 to maintain portions of continuous material connectivity along the length of the shell 800. The shell 800 of this embodiment may be of any suitable size or shape as described above with reference to shell 100.

[0064] As an example, a slotted extensible shell of this embodiment was installed at a test site in Iowa to compare the load versus deflection characteristics of this embodiment of the extensible shell to aggregate piers constructed with a driven tapered pipe. The test site was characterized by soft clay soil and the two comparison aggregate piers (of fine and coarse aggregate) were constructed to a depth of 12 feet below the ground surface.

[0065] For this test of the extensible shell, the shell was formed from High Density Polyethylene polymer and was formed by the rotomolding process. The shell formed a tapered shape that was hexagonal in cross section and tapered downward from an outside diameter of 23 inches (585 mm) at the top of the shell to a diameter of 18 inches (460 mm) at the bottom of the shell. The bottom of this embodiment of the extensible shell was integrally constructed as part of the shell walls as a result of the rotomolding process. In this embodiment of the invention (similar to that shown in Figure 8), 1/4 inch (6.35 mm) wide slots were cut in a circumferential orientation around the extensible shell. The extensible shell was left as a single continuous piece, by not removing material from three of the six corners or spines. The extractable mandrel used in this test was attached to a high frequency hammer, which is often associated with driving sheet piles. The hammer is capable of providing both downward force and vibratory energy for driving the shell into the ground and for compacting aggregate construction material in the shell.

[0066] In this example, the installation process included a 30 inch (0.76 m) diameter pre-drill to a depth of 1.5 feet (0.46 m) below the ground surface. The shell was then placed vertically in the pre-drilled hole and then the shell was driven with an extractable mandrel with exterior dimensions similar to those of the interior of the shell. The shell was driven to a depth of 11 feet (3.4 m) below grade. The mandrel was removed and the extensible shell was then filled with aggregate in four lifts; with each lift about 7.4 cubic feet (0.2 cubic meters) in volume. Each lift was compacted with the downward pressure and vibratory energy of the extractable mandrel.

[0067] After placement and compaction of aggregate within the extensible shell, the top of the shell was situated at about 1.5 feet (0.46 m) below the ground surface. The aggregate backfill was then leveled with the top of the shell, and a concrete cap was then poured above the shell to facilitate load testing.

[0068] The slotted shell pier was load tested using a hydraulic jack pushing against a test frame. Figure 9 is a graph showing results of the load test compared with the aggregate piers described

above. As shown in Figure 9, at a top of pier deflection of one inch, the piers constructed without slotted shells supported a load of 15,000 pounds to 20,000 pounds (67 kN to 89 kN). The pier constructed in this embodiment of the invention supported a load of 77,500 pounds (345 kN) at a top of pier deflection of one inch. The load carrying capacity of the pier constructed in accordance with this embodiment of the invention provided a 3.9 to 5.2 fold improvement when compared to aggregate piers constructed without extensible shells.

[0069] The foregoing detailed description of embodiments refers to the accompanying drawings, which illustrate specific embodiments of the invention. Other embodiments having different structures and operations do not depart from the scope of the invention. The term “the invention” or the like is used with reference to certain specific examples of the many alternative aspects or embodiments of the applicant’s invention set forth in this specification, and neither its use nor its absence is intended to limit the scope of the applicant’s invention or the scope of the claims. Moreover, although the term “step” may be used herein to connote different aspects of methods employed, the term should not be interpreted as implying any particular order among or between various steps herein disclosed unless and except when the order of individual steps is explicitly described. This specification is divided into sections for the convenience of the reader only. Headings should not be construed as limiting of the scope of the invention. It will be understood that various details of the invention may be changed without departing from the scope of the invention. Furthermore, the foregoing description is for the purpose of illustration only, and not for the purpose of limitation.

The embodiments of the present invention for which an exclusive property or privilege is claimed are defined as follows:

1. An extensible shell for constructing a support pier in ground, the extensible shell defining an interior for holding granular construction material and defining an opening for receiving the granular construction material into the interior, wherein the shell is flexible such that the shell expands laterally outward when granular construction material is compacted in the interior of the shell.
2. The extensible shell of claim 1, further comprising a first end that defines the opening, and wherein the shell is shaped to taper downward from the first end to an opposing second end of the shell.
3. The extensible shell of claim 2, wherein the second end defines a substantially flat, blunt surface.
4. The extensible shell of claim 2, wherein a cross-section of the shell forms one of a substantially hexagonal shape and a substantially octagonal shape along a length of the shell extending between the first and second ends.
5. The extensible shell of claim 2, wherein a cross-section of the first end is sized larger than a cross-section of the second end.
6. The extensible shell of any one of claims 1 to 5, wherein the shell is comprised of plastic.
7. The extensible shell of any one of claims 1 to 6, wherein the shell defines a plurality of apertures extending between an interior of the shell to an exterior of the shell.
8. The extensible shell of any one of claims 1 to 7, wherein the shell is substantially cylindrical in shape.
9. The extensible shell of any one of claims 1 to 7, wherein the shell is substantially conical in shape.

10. A method for constructing a support pier in ground, the method comprising:
 - (a) positioning an extensible shell into ground, the shell defining an interior for holding granular construction material and defining an opening for receiving the granular construction material into the interior, wherein the shell is flexible such that the shell expands when granular construction material is compacted in the interior of the shell;
 - (b) filling at least a portion of the interior of the shell with the granular construction material; and
 - (c) compacting the granular construction material in the interior of the shell to form a support pier.
11. The method of claim 10, wherein the shell comprises a first end that defines the opening, and wherein the shell is shaped to taper downward from the first end to an opposing second end of the shell.
12. The method of claim 11, wherein the second end defines a substantially flat, blunt surface.
13. The method of claim 11, wherein a cross-section of the shell forms one of a substantially hexagonal shape and a substantially octagonal shape along a length of the shell extending between the first and second ends.
14. The method of claim 11, wherein a cross-section of the first end is sized larger than a cross-section of the second end.
15. The method of any one of claims 10 to 14, wherein the shell is comprised of plastic.
16. The method of any one of claims 10 to 15, wherein the shell defines a plurality of apertures extending between the interior of the shell to an exterior of the shell.
17. The method of claim 16, further comprising applying vacuum pressure through the shell.
18. The method of any one of claims 10 to 17, wherein the shell is substantially cylindrical in shape.

19. The method of any one of claims 10 to 17, wherein the shell is substantially conical in shape.
20. The method of any one of claims 10 to 19, wherein the positioning in step (a) further comprises partially filling the shell with the granular construction material and driving the shell into the ground subsequent to partially filling the shell.
21. The method of claim 20, wherein driving the extensible shell comprises applying a force to a mandrel for driving the shell into the ground.
22. The method of any one of claims 10 to 19, wherein the positioning in step (a) further comprises first forming a cavity in the ground and subsequently driving the extensible shell into the cavity.
23. The method of claim 22, wherein the cavity is at least partially filled with granular construction material after forming and prior to the driving of the extensible shell into the cavity.
24. The method of any one of claims 10 to 19, wherein the compacting in step (c) is performed with a primary mandrel.
25. The method of claim 24, further comprising an additional compacting step performed with a second mandrel that has a larger cross-sectional area than the primary mandrel.
26. A method for constructing a support pier in ground, the method comprising:
 - (a) forming a cavity in the ground;
 - (b) partially backfilling the cavity with an aggregate construction material;
 - (c) positioning an extensible shell into the cavity, the shell defining an interior for holding granular construction material and defining an opening for receiving the granular construction material into the interior, wherein the shell is flexible such that the shell expands when granular construction material is compacted in the interior of the shell;

- (d) filling at least a portion of the interior of the shell with the granular construction material; and
 - (e) compacting the granular construction material in the interior of the shell to form a support pier.
27. The extensible shell of claim 1, further comprising a plurality of slots extending between an interior of the shell to an exterior of the shell, the slots being generally transverse to a centerline along the length of the shell.
28. The extensible shell of claim 27, wherein the slots are discontinuous around a circumference of the shell thereby maintaining portions of continuous material connectivity along the length of the shell.
29. The extensible shell of claim 27, wherein the slots have a width in the range of 6.35 mm to 9.53 mm.
30. The extensible shell of claim 27, wherein the slots are spaced at a distance of 152 mm from one another.
31. The method of claim 10, wherein the shell further comprises a plurality of slots extending between an interior of the shell to an exterior of the shell, the slots being generally transverse to a centerline along the length of the shell.
32. The method of claim 31, wherein the slots are discontinuous around a circumference of the shell thereby maintaining portions of continuous material connectivity along the length of the shell.
33. The method of claim 31, wherein the slots have a width in the range of 6.35 mm to 9.53 mm.
34. The method of claim 31, wherein the slots are spaced at a distance of 152 mm from one another.

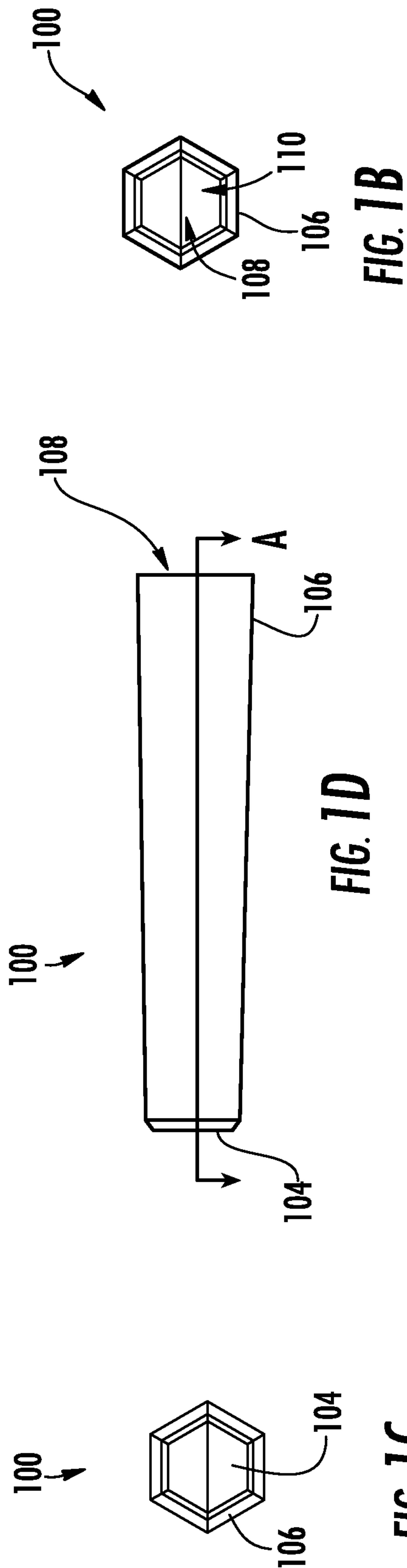
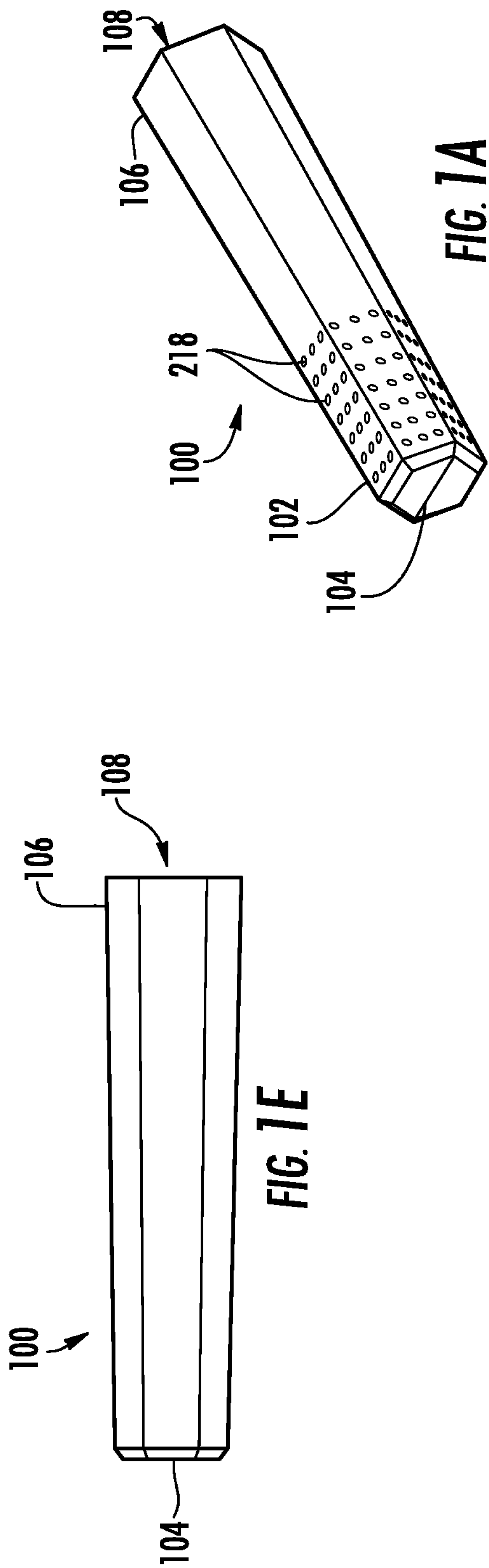

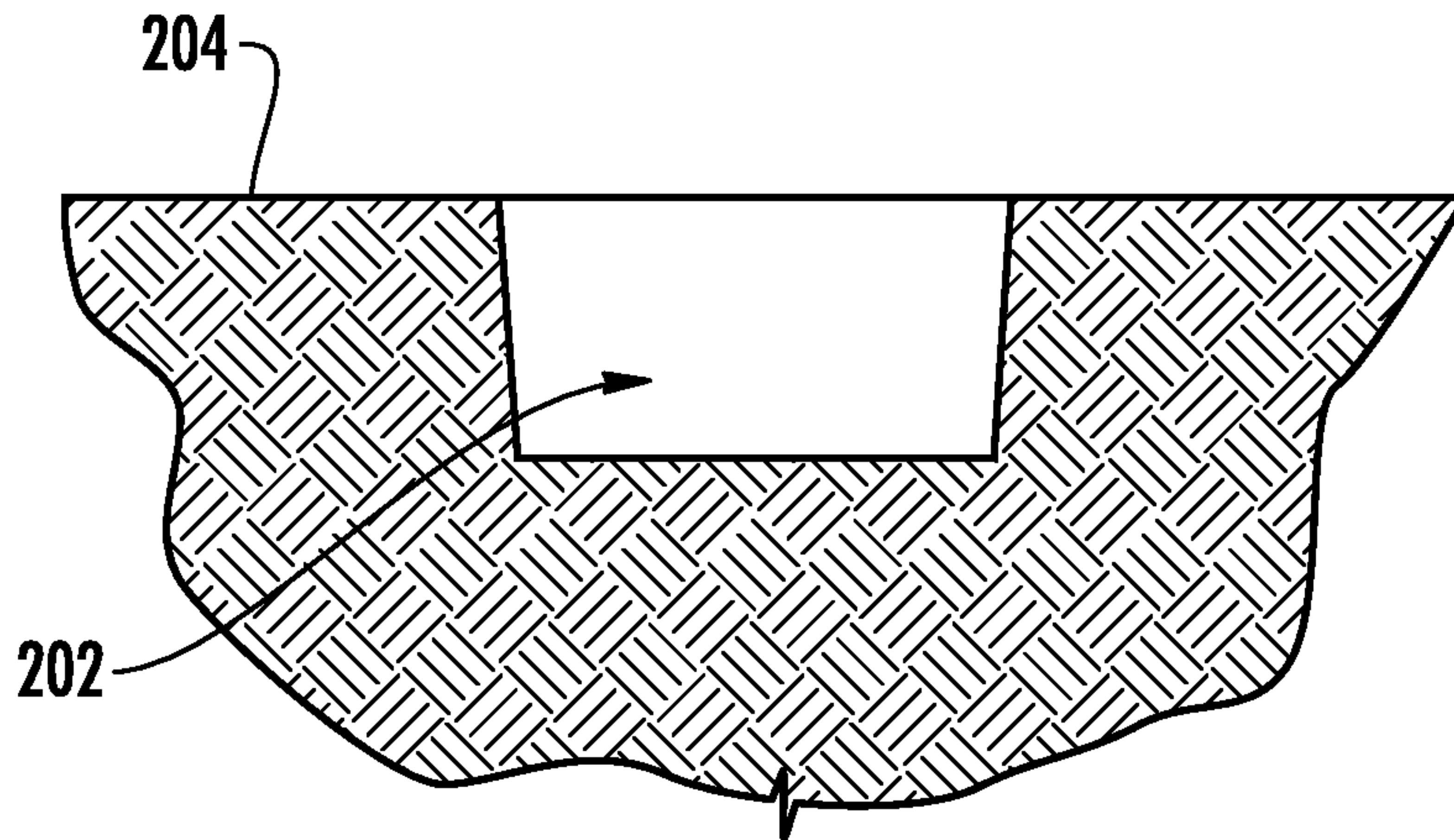

FIG. 2A

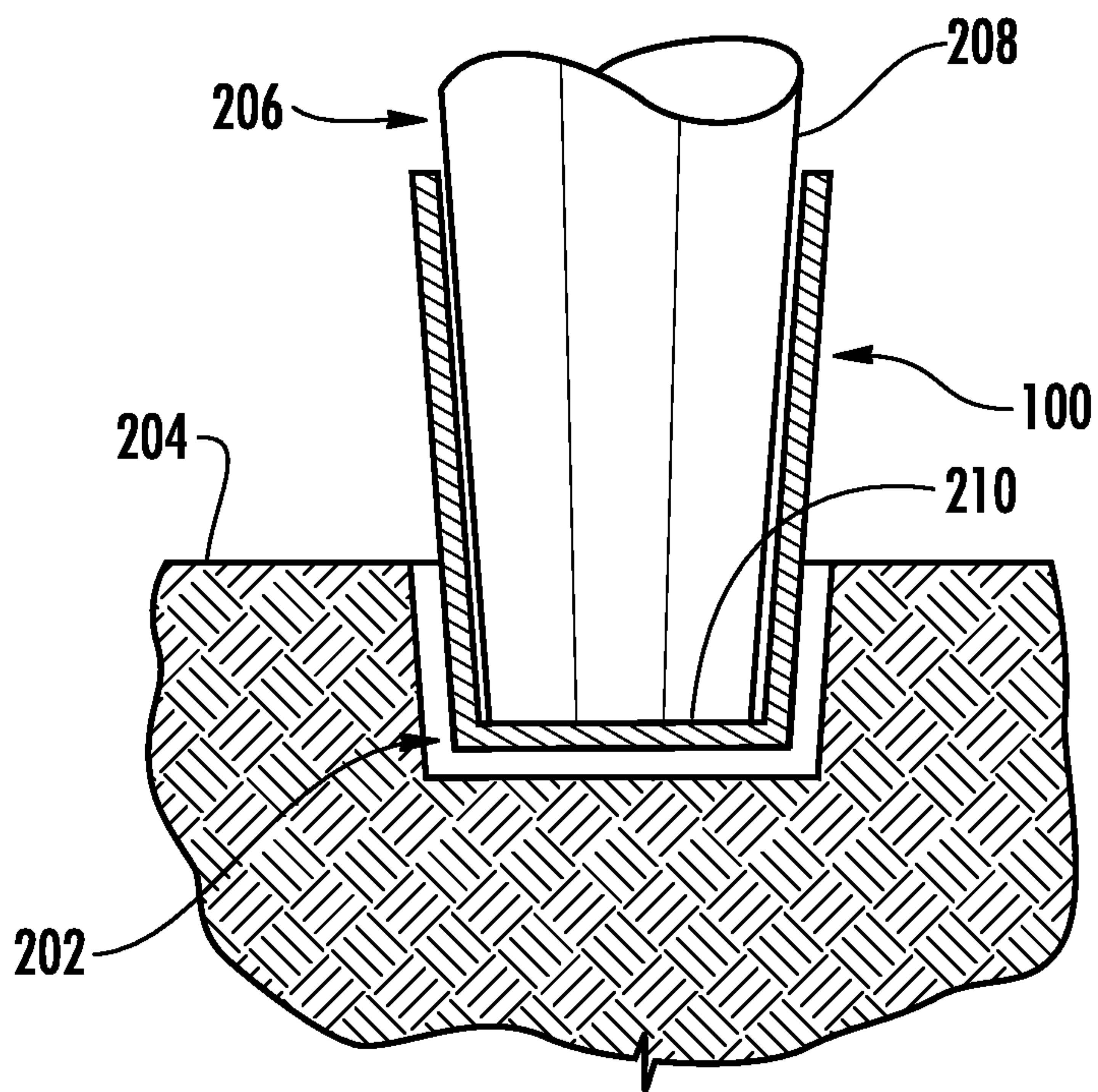

FIG. 2B

3/12

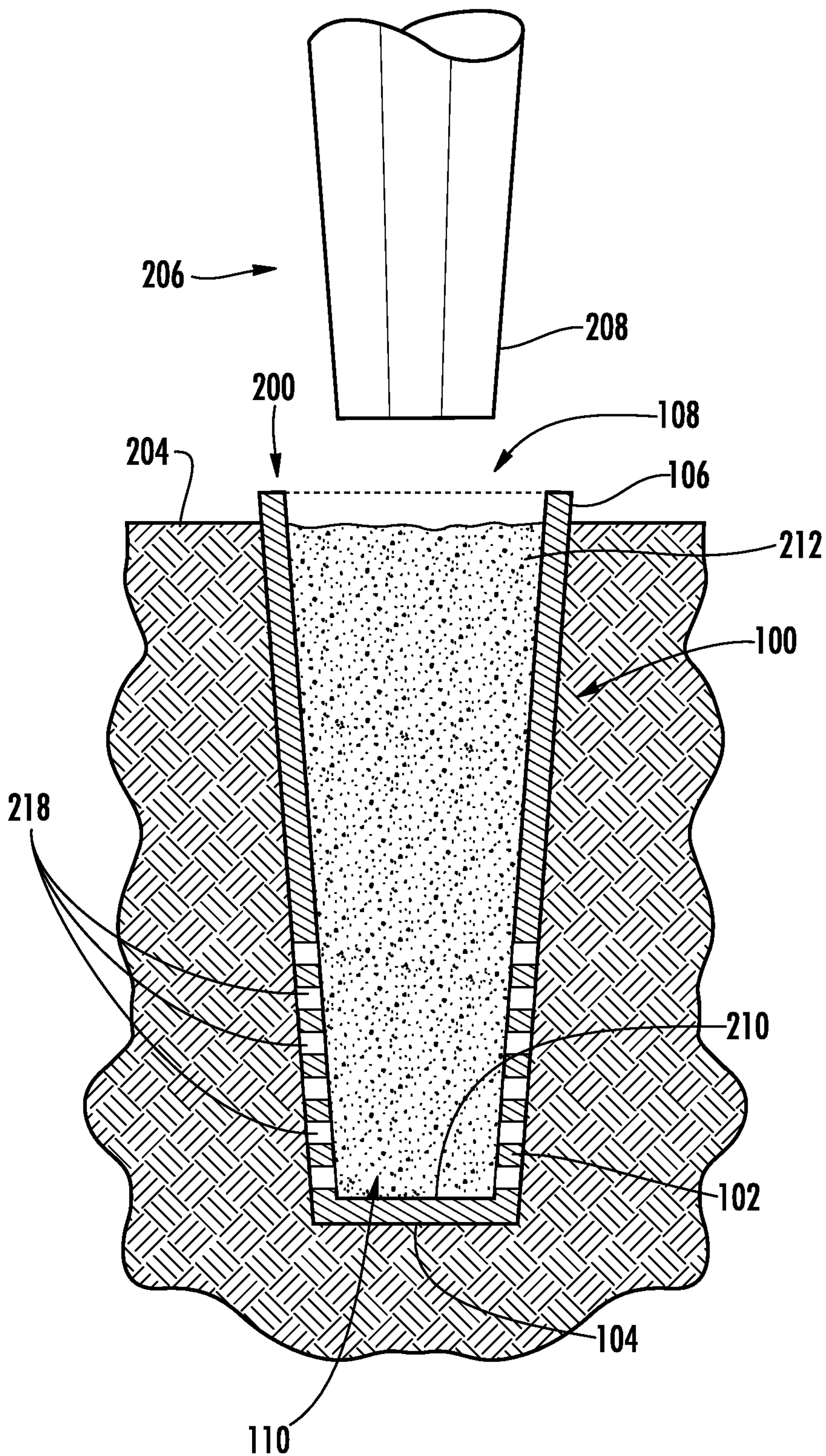

FIG. 2C

4/12

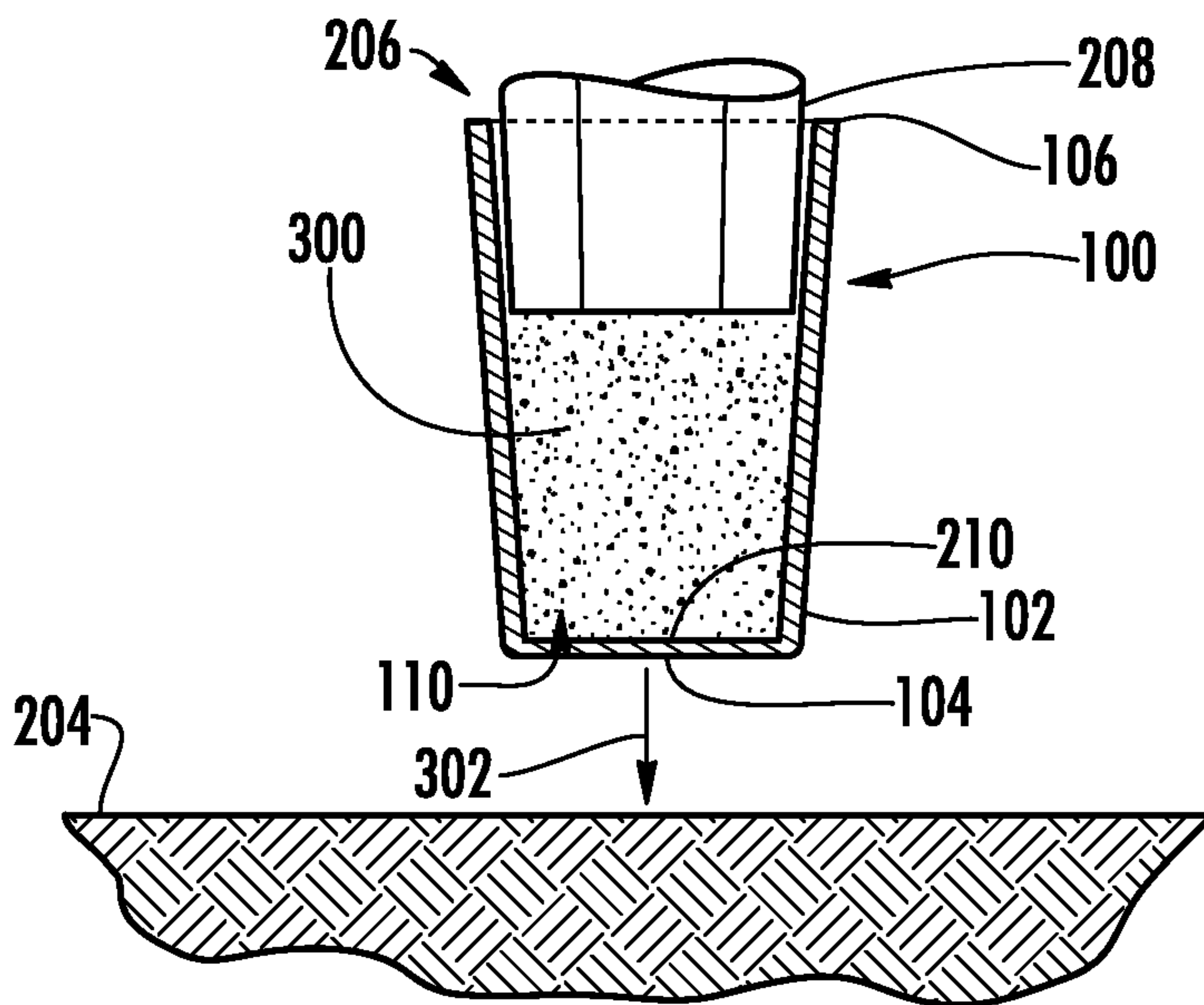

FIG. 3A

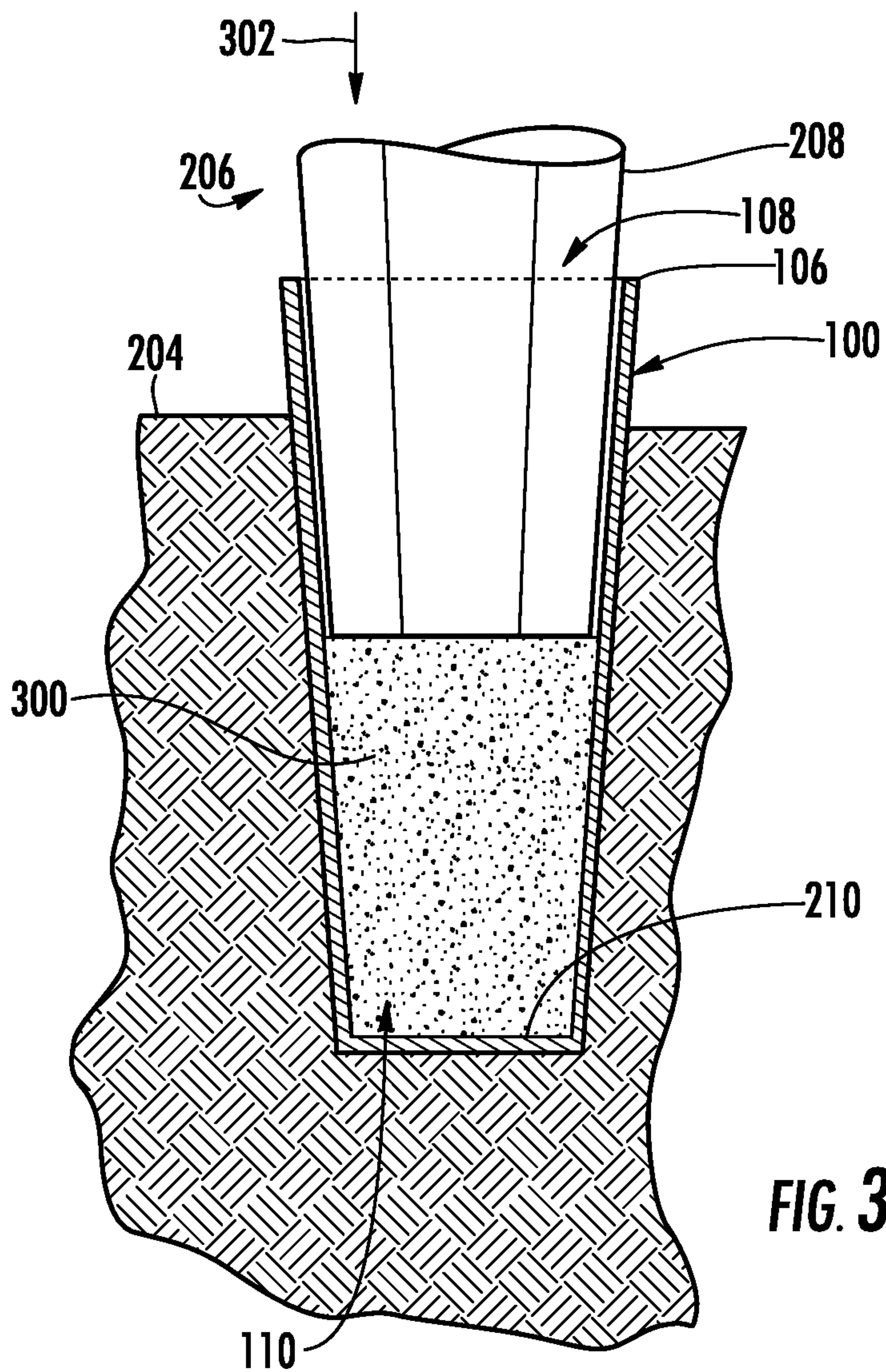

FIG. 3B

5/12

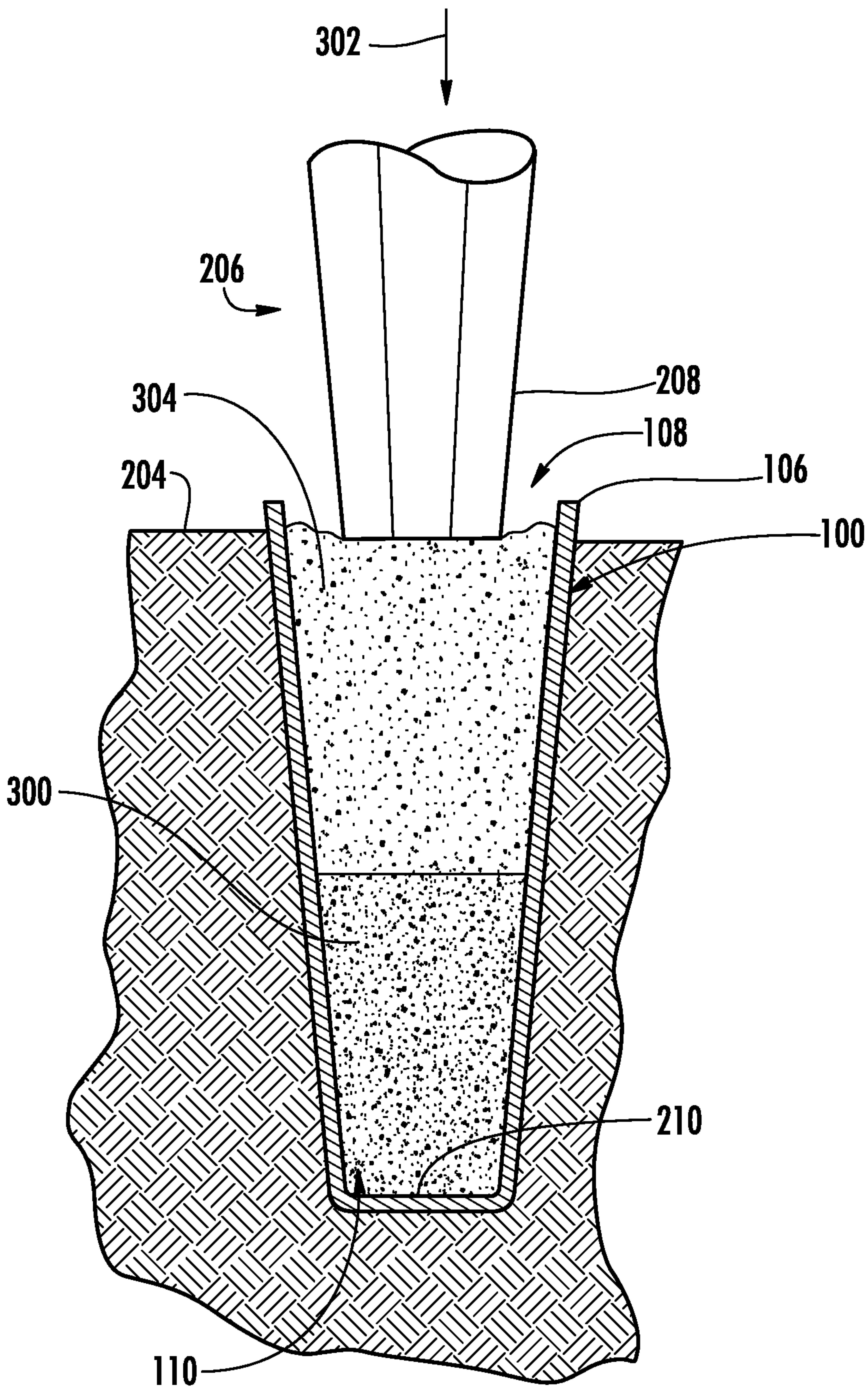

FIG. 3C

6/12

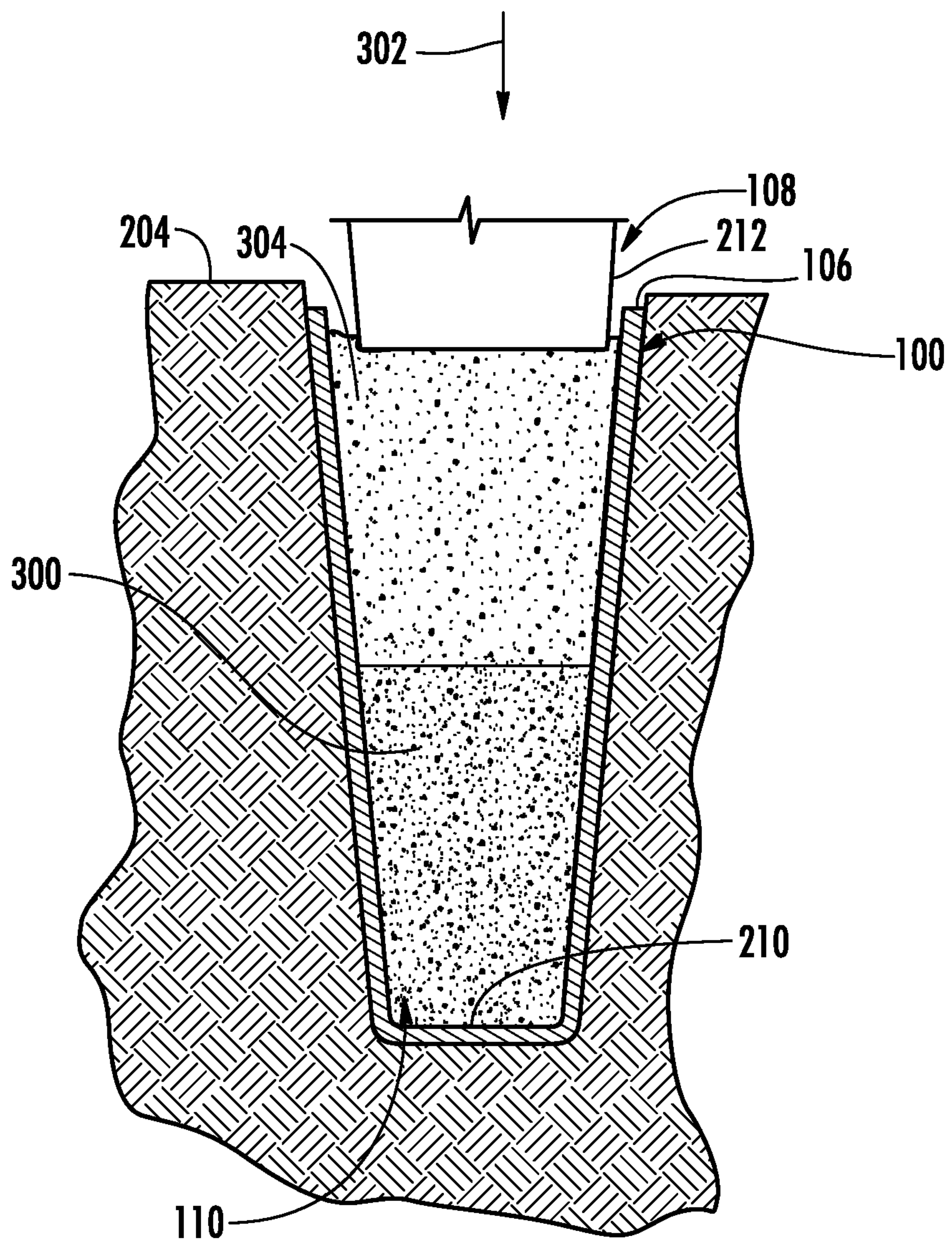

FIG. 3D

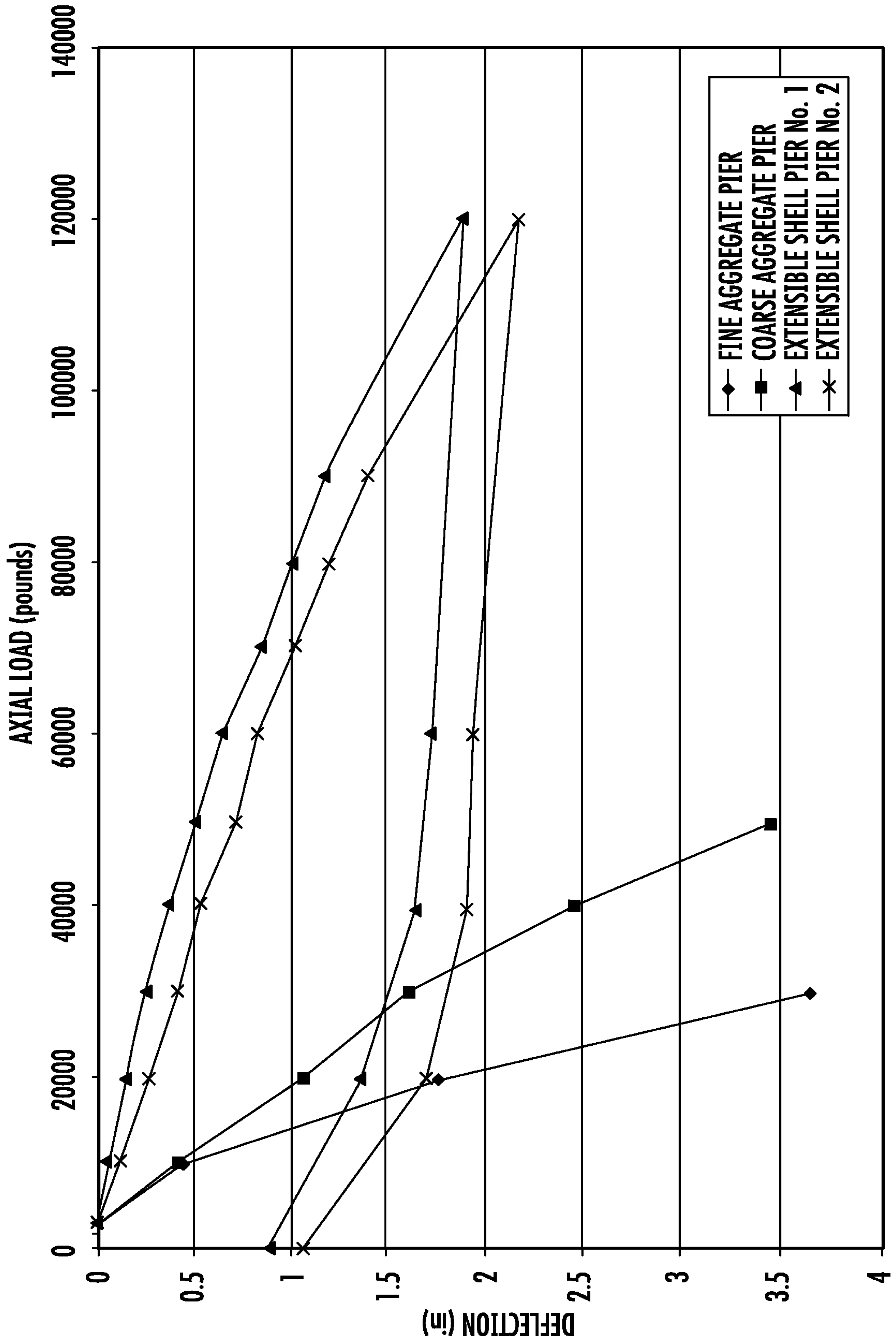

FIG. 4

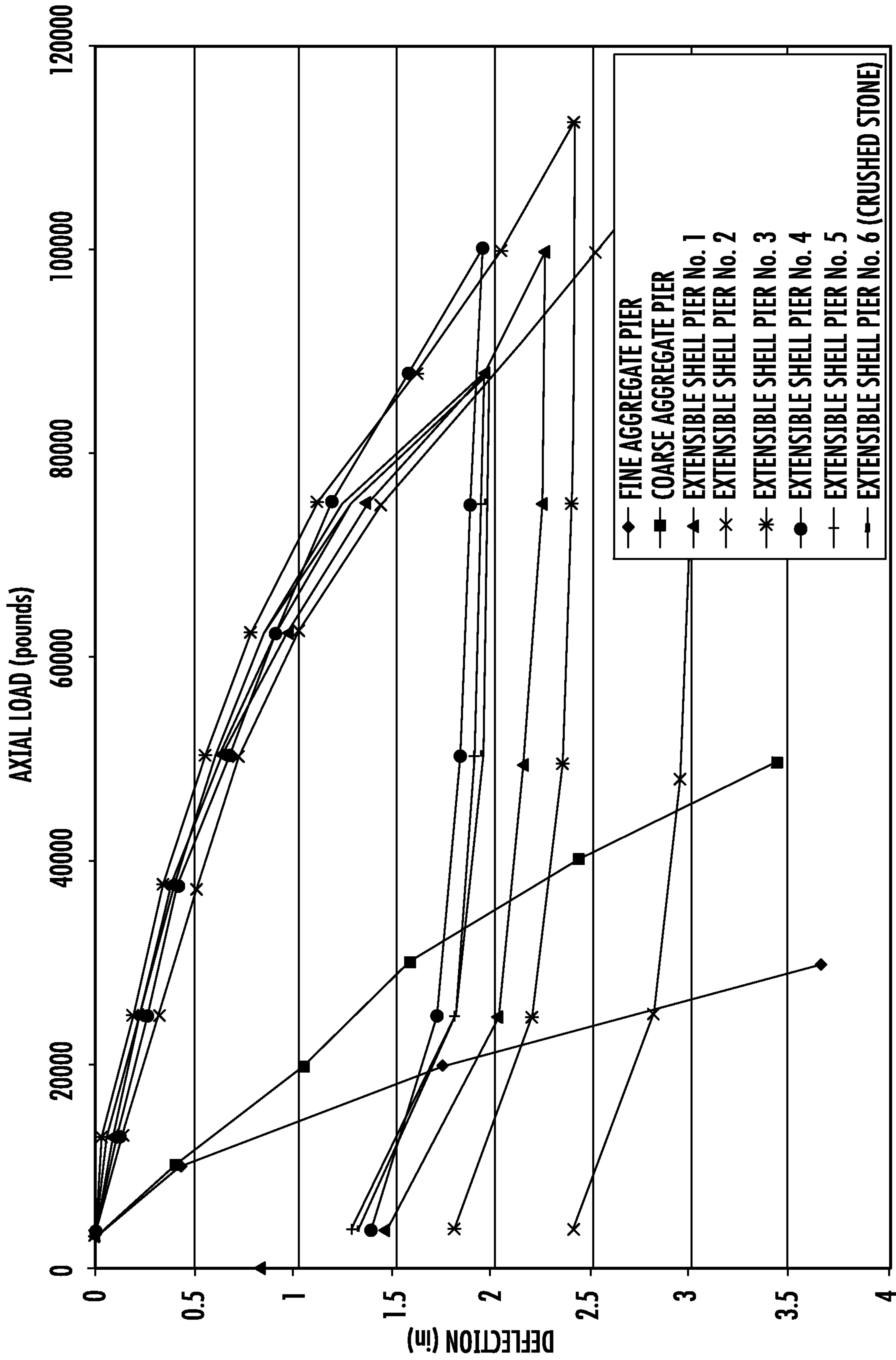

FIG. 5

9/12

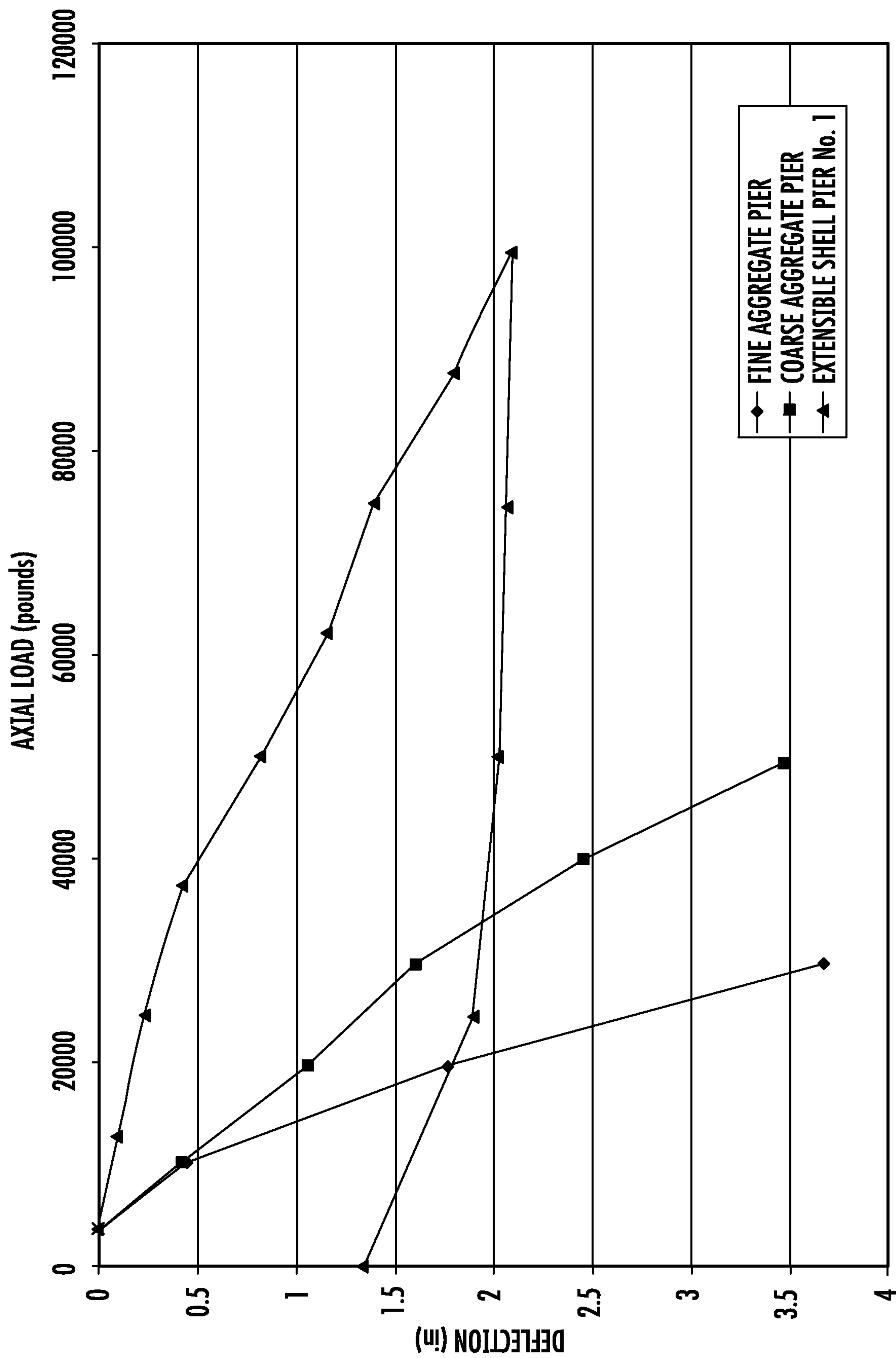

FIG. 6

10/12

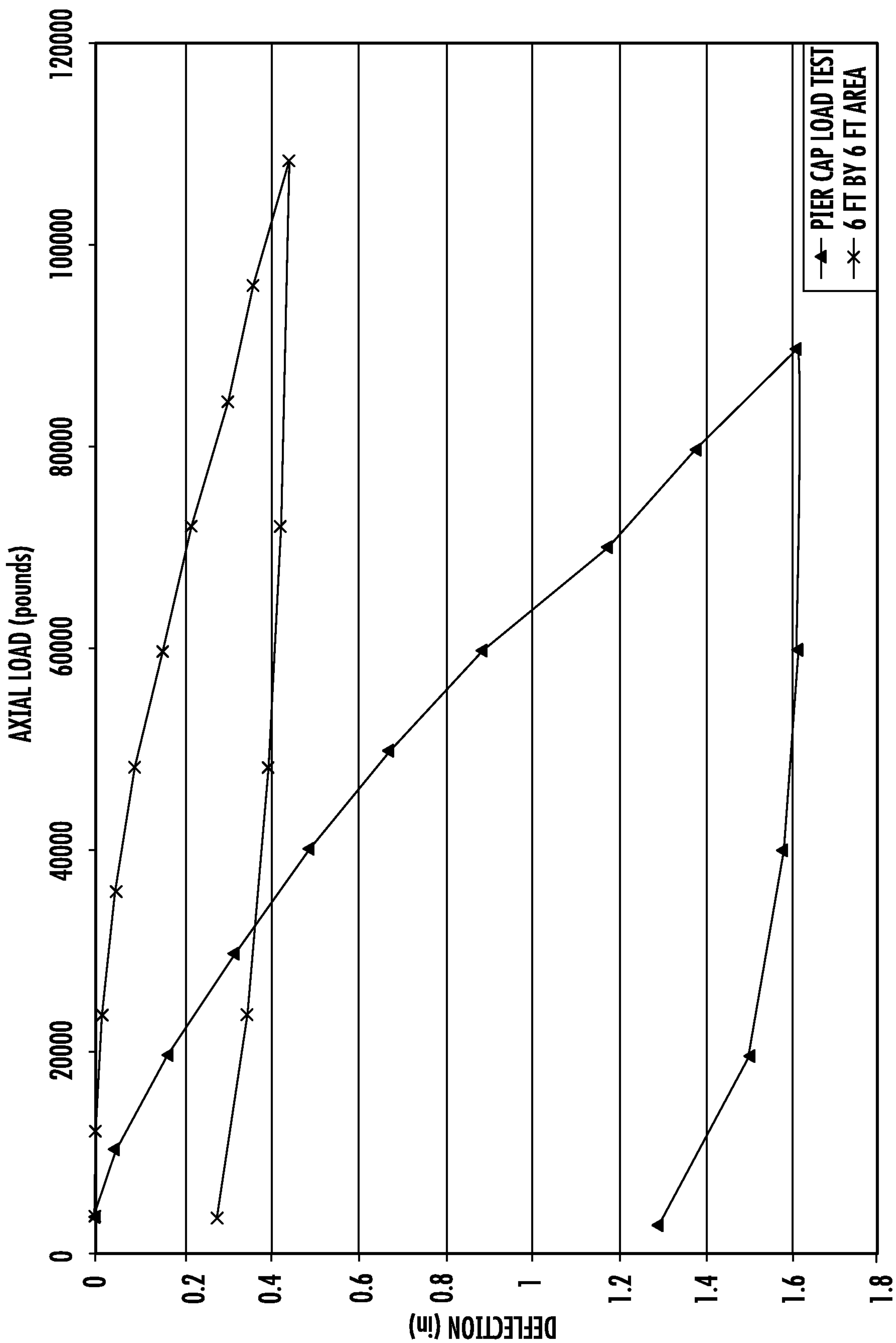
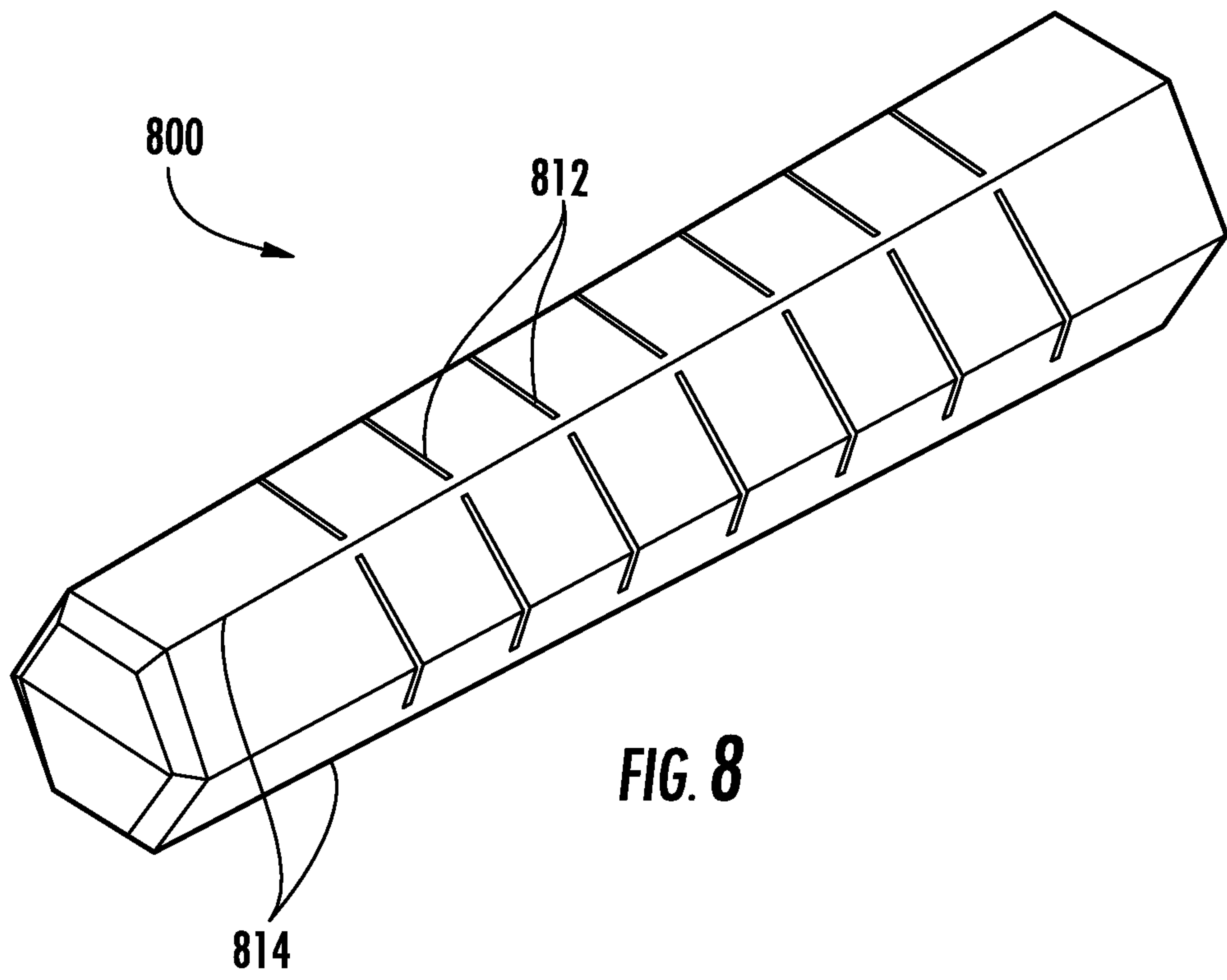

FIG. 7



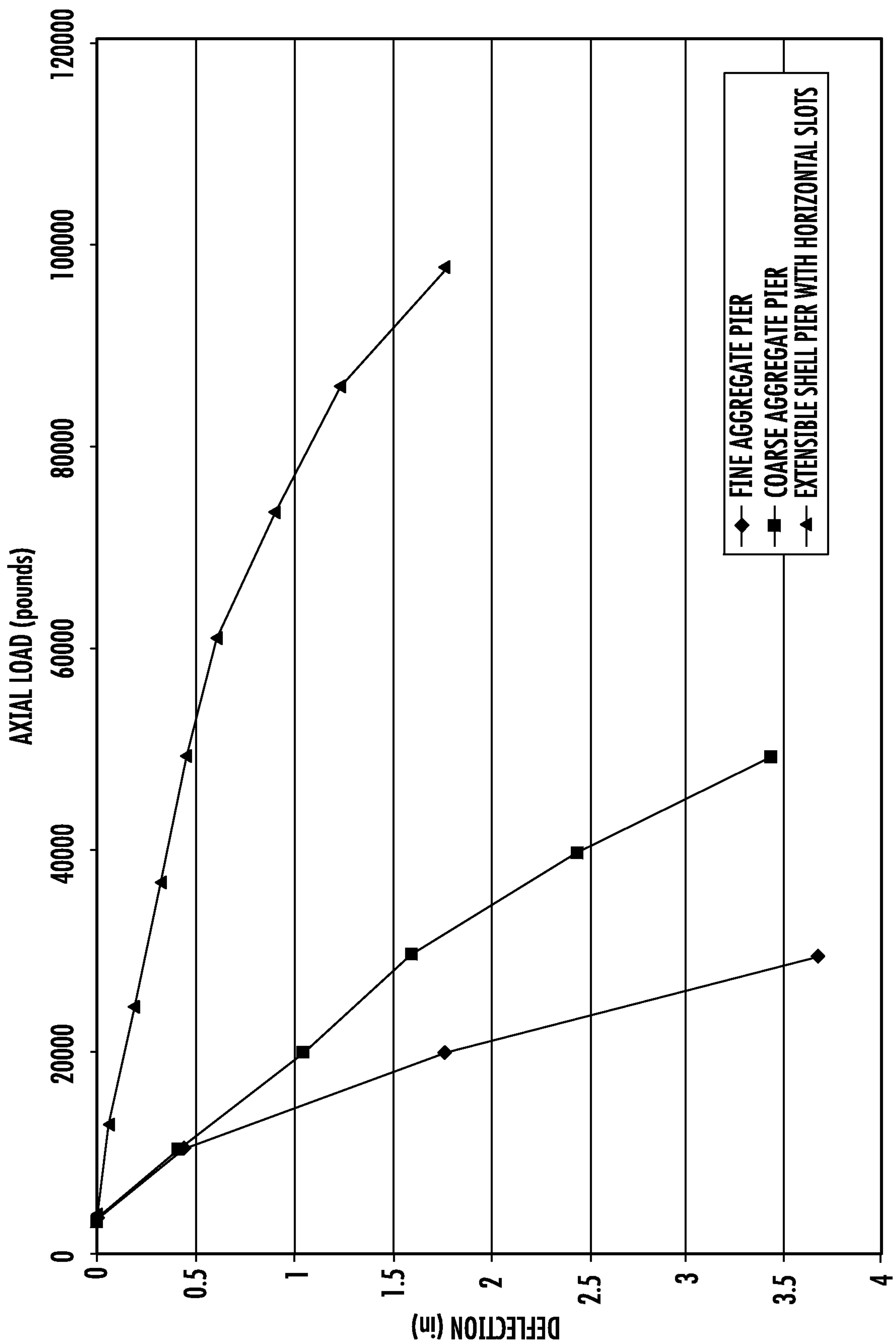

FIG. 9

