

(19)



(11)

EP 0 944 150 B1

(12)

EUROPEAN PATENT SPECIFICATION

(45) Date of publication and mention of the grant of the patent:
25.06.2008 Bulletin 2008/26

(51) Int Cl.:
H02H 5/08 (2006.01)

(21) Application number: **99104014.8**

(22) Date of filing: **12.03.1999**

(54) **Improved Buchholz relay**

Verbessertes Buchholz Relais

Relais de Buchholz amélioré

(84) Designated Contracting States:
AT BE CH DE ES FI FR GB GR LI NL PT SE

(30) Priority: **19.03.1998 IT PD980059**

(43) Date of publication of application:
22.09.1999 Bulletin 1999/38

(73) Proprietor: **COMEM S.p.A.**
36054 Montebello Vicentino (Vicenza) (IT)

(72) Inventor: **Dal Lago, Silvio**
36100 Vicenza (IT)

(74) Representative: **Iannone, Carlo Luigi et al**
Barzanò & Zanardo Roma S.p.A.
Via Piemonte 26
00187 Roma (IT)

(56) References cited:
BE-A- 678 625 **DE-A- 3 248 275**
US-A- 2 952 753 **US-A- 4 282 413**

EP 0 944 150 B1

Note: Within nine months of the publication of the mention of the grant of the European patent in the European Patent Bulletin, any person may give notice to the European Patent Office of opposition to that patent, in accordance with the Implementing Regulations. Notice of opposition shall not be deemed to have been filed until the opposition fee has been paid. (Art. 99(1) European Patent Convention).

Description

[0001] The present invention relates to a Buchholz relay.

[0002] Currently it is indispensable to provide all oil-filled transformers with a Buchholz relay so that the generation of gas and the presence of significant oil currents are reported immediately.

[0003] The Buchholz relay must be applied at the highest point of the transformer and below the expansion vessel, which is commonly known as conservator, and must be filled with oil during normal operation.

[0004] In some cases it is convenient to appropriately tilt the transformer in order to ensure that the Buchholz relay assumes the highest position on the transformer.

[0005] The presence of gas and/or of considerable oil currents inside a transformer is in fact always caused by malfunction.

[0006] The gas can in fact, in a first case, originate from outside and be introduced through the circulation pumps or, as an alternative, it can be the result of the decomposition of the liquid or solid insulators caused by overheating or by the onset of electric arcs.

[0007] Likewise, the presence of strong oil currents is certainly due to the occurrence of severe faults with excessive gas production or, in other cases, to the presence of short-circuits or leaks in the tank of the transformer.

[0008] The relay is usually constituted by a body obtained from aluminum alloy castings, inside which a supporting frame is placed for at least one movable device which comprises an upper floater and a lower floater for operating magnetic switches.

[0009] In particular, the upper floater enables/disables an alarm circuit by means of the corresponding switch, while the lower floater operates a disconnection circuit in an equivalent manner.

[0010] When gas forms inside the transformer, said gas, which tends to escape upward, accumulates inside the relay, lowering the level of the oil; this lowering is detected first by the upper floater, which accordingly operates the alarm circuit, and if the accumulation of gas continues it is then detected by the lower floater, which is directly connected to the circuit for disconnecting the transformer from the power supply line.

[0011] In order to detect the presence of strong oil currents, the Buchholz relay is provided with a suitably adjusted flap which is sensitive to the flow-rate of the oil current and is also connected to the circuit for disconnecting the transformer from the power supply.

[0012] The flap is usually obtained monolithically with the lower floater, and when significant oil currents occur, the flap, by rotating about its own axis because it is directly affected by the flow, causes the intervention of the switch for closing the disconnection circuit.

[0013] A possible particular characteristic is that the contact of the disconnection circuit is kept closed whenever the flap rotates under the action of intense oil currents or because the level of the oil has dropped below

a certain value.

[0014] In order to reopen the contact, the flap must be returned to the normal position by means of a suitable pushbutton arranged on the cover of the relay.

5 **[0015]** Usually the flap must be adjusted appropriately so as to be sensitive to currents in excess of a certain preset limit.

[0016] Said limit is usually set by standards or by the user, so that the manufacturer must produce different relays depending on the setting of the flap.

10 **[0017]** Actually, manufacturers of Buchholz relays are currently able to modify the adjustment of the flap by adding or removing suitable counterweights which are applied to its lower part.

15 **[0018]** In other cases, the flap is adjusted by moving it appropriately along suitable guides or by using fixing screws, so as to reduce the surface of the flap that is affected by the oil currents.

[0019] For example, DE 3248275 A discloses a Buchholz relay having all the features of the preamble of claim 1.

20 **[0020]** Unfortunately, the resulting flap is enormously impaired by the fact that it is monolithic with the lower floater; moreover, adjustment performed in the above-mentioned manner is inaccurate and sometimes difficult to provide in practice.

[0021] The result of these drawbacks is directly a reduced signaling effectiveness of Buchholz relays.

25 **[0022]** The aim of the present invention is to provide an improved Buchholz relay which solves the above drawbacks of conventional relays.

30 **[0023]** Within the scope of this aim, an important object of the present invention is to provide a Buchholz relay which ensures good characteristics in terms of safety and most of all precision in the setting of the intervention threshold.

[0024] Another important object of the present invention is to provide a Buchholz relay whose configuration is simpler than in conventional types.

35 **[0025]** Another important object of the present invention is to provide a Buchholz relay whose assembly is simple with respect to conventional relays.

[0026] Another object of the present invention is to provide a Buchholz relay which, without having to differentiate the production process allows end users to select the degree of sensitivity of intervention in the presence of oil currents.

40 **[0027]** This aim, these objects and others which will become apparent hereinafter are achieved by a Buchholz relay which comprises, to be immersed in an oil bath, a supporting frame for magnetic switches for closing circuits which are operated by movable devices, of which at least one is of the floater type and at least one is of the flap type rotatably associated with said frame, characterized in that said flap device, which has a surface sensitive to the presence of oil currents, is independent of said floaters.

45 **[0028]** Further characteristics and advantages of the

present invention will become apparent from the following detailed description of a preferred embodiment thereof, illustrated only by way of non-limitative example in the accompanying drawings, wherein:

Figure 1 is a partially sectional view of a transformer provided with a relay of the Buchholz type according to the invention;

Figure 2 is a front view of a Buchholz relay according to the invention;

Figure 3 is a perspective view of a detail of the relay of Figure 2;

Figure 4 is a view of some of the components shown in Figure 3;

Figure 5 is an exploded view of one of the components of the Buchholz relay shown in Figure 4.

[0029] With reference to the above figures, an oil-filled transformer is generally designated by the reference numeral 10 and has a tank with radiating elements 11 to which an expansion vessel 12 of a per se known type is connected in an upward region.

[0030] The transformer 10 is of a per se known type, and Figure 1 illustrates high-voltage insulators 13, an oil drain 14 and a thermometer 15 for detecting the oil temperature.

[0031] Transformer 10 is provided with a Buchholz relay, according to the invention, which is designated by the reference numeral 16 and is integrated between the transformer and the expansion vessel 12.

[0032] The relay 16 is constituted by a hermetic body 17 which is preferably made of cast aluminum alloy and in which inspection ports 18 are formed preferably made of tempered glass and provided with graduated scales 19.

[0033] In the upper part, the relay 16 is provided with a cover 20 from which a gas drain cock 21, a pneumatic test valve 22 and a grommet 23 protrude.

[0034] In a downward region, the relay 16 has an oil drain plug 24.

[0035] Inside the relay 16 there is provided a frame, preferably made of plastics, in an upward region whereof holes 26 are defined for engaging the cover 20 by means of fixing screws which are not shown in the above figures for the sake of simplicity.

[0036] The frame 25 has a structure which is mostly longitudinally elongated and on which two posts 27 are provided in which seats 28 are formed for accommodating magnetic switches 29.

[0037] Each one of the switches 29 is of a per se known type and has, inside a bulb, a magnet and electrical contacts, not shown in the figures, which are directly connected, in this case, to an alarm circuit or to a disconnection circuit.

[0038] An upper movable device 30 and an equivalent lower movable device 31 are fixed to the frame 25; each device is of a per se known type and comprises a floater 32 of the lever type.

[0039] In this embodiment, the upper movable device 30 directly actuates the alarm circuit in a per se known manner, while the lower movable device 31 is connected to the disconnection circuit.

5 **[0040]** The relay 16 is provided with a movable device of the flap type, designated by the reference numeral 33, which is constituted by a flat member 37 from one end of which a pivot 35 protrudes.

10 **[0041]** The two ends 36 of pivot 35 can rotatably engage the posts 27 of the frame 25, as specified in greater detail hereinafter.

[0042] The flat member 37 has, in this configuration, a rectangular structure from which sides 39 perpendicular thereto protrude starting from the outer sides 38.

15 **[0043]** The sides 39 are parallel and are kept together by a tubular support 40 which protrudes monolithically from them with an axis which is parallel to the pivot 35.

[0044] In particular, the tubular support 40 is suitable to contain a conveniently complementarily shaped cylindrical counterweight 41.

[0045] The counterweight 41 is preferably made of brass.

20 **[0046]** Sides 39 are flat, with a substantially trapezoidal plan which is delimited by the pivot 35 in an upward region and by the end 42 of the flat member 37 in a downward region.

25 **[0047]** In particular, it is important to note that sides 39 uniformly distribute the effect of the presence of the counterweight 41 along the entire extension of the flat member 37.

30 **[0048]** In this embodiment, first prefractures 43 are formed in flat member 37 and are arranged longitudinally at the outer sides 38; second prefractures 44 are also provided therein and lie transversely so as to connect the first prefractures 43.

35 **[0049]** In this manner, the combination of the first and second prefractures 43 and 44 forms, on the flat member 37, detachable portions 45 starting from the lower end 42.

40 **[0050]** The movable device of the flap type 33 is preferably made of plastics.

[0051] Guides 46 are formed on the posts 27 of frame 25 in a region located below the lower movable device 32 of the floater type.

45 **[0052]** The complementarily shaped ends 36 of the pivot 35 of the movable flap device 33 can be made to slide along guides 46.

[0053] Each one of guides 46 has, in the innermost end portion of its extension, a seat 47 which is suitable to accommodate the end 36 of the pivot 35 of the movable flap device 33.

50 **[0054]** The assembly of the movable device to the frame 25 accordingly occurs by snap action after the ends 36 of the pivot 35 have moved along the guides 46, by insertion and consequent locking in the seats 47.

55 **[0055]** The operation of the Buchholz relay 16 according to the present invention is extremely simple, since when the level of the oil lowers, the floater 32 of the upper device 30 directly actuates the alarm circuit.

[0056] Any further lowering of the level of the oil is detected by the floater 32 of the lower device 31, whereby immediate closure of the disconnection circuit is achieved.

[0057] The relay 16, in particular, is sensitive to the occurrence of oil currents whose flow-rate exceeds a pre-set limit which can be determined by the end user.

[0058] When an oil current occurs whose flow-rate exceeds the limit set by the adjustment, the movable flap device 33 in fact rotates with respect to the frame 25 so as to directly actuate said disconnection circuit.

[0059] The flow-rate limit is determined by the extent of the surface of the flat member 37, so that in order to achieve maximum sensitivity of intervention of the flap device 33 it is sufficient to use a flat member 37 which comprises all its detachable portions 45.

[0060] If instead the user wishes to adjust the intervention of the flap device 33 so as to increase the allowed flow-rate, for example going from a minimum allowed flow-rate limit (i.e., a maximum-sensitivity limit) obtained with the flat member 37 complete with all the portions 45, to a higher flow-rate limit, it is sufficient to detach a suitable number of portions 45 by way of said first and second prefractures 43 and 44.

[0061] In this manner, the manufacturer can produce Buchholz relays without having to differentiate any of their components and leaving the end user the freedom to choose the intervention threshold in case of oil currents.

[0062] It is evident that the adjustment of the movable flap device 33 is of the discrete type and must be studied accurately as a function of the size and number of the detachable portions 45, in order to make the relay 16 conveniently sensitive to oil currents.

[0063] In practice, it has been observed that the present invention widely achieves the intended aim and all the objects.

[0064] An important advantage has in fact been achieved with the present invention, in that a Buchholz relay has been provided which can ensure excellent safety characteristics and most of all precision in setting the threshold of intervention when oil currents occur.

[0065] A fundamental advantage achieved with the present invention is that a Buchholz relay has been provided which, without having to differentiate the production process, allows end users to choose the degree of sensitivity of intervention of the relay in the presence of oil currents.

[0066] Another advantage is ensured in that the Buchholz relay of the invention allows to set the intervention threshold in case of oil currents in a manner which is extremely simple and fast to perform and most of all is absolutely precise.

[0067] Another important advantage has been achieved with the present invention in that a Buchholz relay has been provided whose configuration is simpler than in conventional types.

[0068] Where technical features mentioned in any

claim are followed by reference signs, those reference signs have been included for the sole purpose of increasing the intelligibility of the claims and accordingly, such reference signs do not have any limiting effect on the interpretation of each element identified by way of example by such reference signs.

Claims

1. A Buchholz relay (16) comprising, to be immersed in an oil bath, a supporting frame (25) for magnetic switches (29) for closing circuits which are operated by movable devices (30, 31), of which at least one is of the floater type (32) and at least one is of the type with a flap (33) rotatably associated with said frame (25), wherein said movable flap device (33) is independent of said floaters (32) and comprises a flat member (37) provided with a pivot (35) which is rotatably associated with said frame (25) by way of its ends (36), said movable flap device (33) also having a surface which is sensitive to the presence of oil currents so that said movable flap device (33) is able to rotate with respect to said frame (25) under the action of an oil current, at least one portion of said surface of the movable flap device (33) sensitive to the presence of oil currents being also reducible, **characterised in that** prefractures (43, 44) are formed in said flat member (37) so as to constitute said reducible surface, said prefractures (43, 44) forming at least one detachable portion (45).
2. The relay (16) according to claim 1, **characterised in that** said movable flap device (33) comprises a tubular support (40) inside which a counterweight (41) can be inserted.
3. The relay (16) according to claim 1, **characterised in that** mutually opposite guides (46) for the sliding of the ends (36) of said pivot (35) are formed in said frame (25), each guide (46) ending with a seat (47) which is adapted for the snap insertion of said ends (36).
4. The relay (16) according to claim 1, **characterised in that** said movable flap device (33) is made of plastics.

Patentansprüche

1. Buchholzrelais (16), das zum Eintauchen in ein Ölbad einen Trägerrahmen (25) für Magnetschalter (29) zum Schließen von Schaltkreisen umfasst, die durch bewegliche Einrichtungen (30, 31) betätigt werden, von denen zumindest eine von dem Schwimmertyp (32) ist und zumindest eine von dem Typ mit einer Klappe (33) ist, die dem Rahmen (25)

- drehbar zugeordnet ist, wobei die bewegliche Klappeneinrichtung (33) unabhängig von den Schwimmern (32) ist und ein flaches Element (37) umfasst, das mit einem Drehzapfen (35) versehen ist, der dem Rahmen (25) mittels seiner Enden (36) drehbar zugeordnet ist, wobei die bewegliche Klappeneinrichtung (33) auch eine Fläche aufweist, die gegenüber dem Vorhandensein von Ölströmen empfindlich ist, sodass die bewegliche Klappeneinrichtung (33) in der Lage ist, in Bezug auf den Rahmen (25) unter der Wirkung eines Ölstromes zu rotieren, wobei zumindest ein Abschnitt der Fläche der beweglichen Klappeneinrichtung (33), die gegenüber dem Vorhandensein von Ölströmen empfindlich ist, auch zerlegbar ist,
- dadurch gekennzeichnet, dass**
in dem flachen Element (37) Vorbruchstellen (43, 44) gebildet sind, um die zerlegbare Fläche zu bilden, wobei die Vorbruchstellen (43, 44) zumindest einen abnehmbaren Abschnitt (45) bilden.
2. Relais (16) nach Anspruch 1,
dadurch gekennzeichnet, dass
die bewegliche Klappeneinrichtung (33) einen rohrförmigen Träger (40) umfasst, in den ein Gegengewicht (41) eingesetzt sein kann.
3. Relais (16) nach Anspruch 1,
dadurch gekennzeichnet, dass
einander gegenüberliegende Führungen (46) zum Verschieben der Enden (36) des Drehzapfens (35) in dem Rahmen (25) gebildet sind, wobei jede Führung (46) mit einem Sitz (47) endet, der für das Einsetzen der Enden (36) mittels einer Schnappverbindung eingerichtet ist.
4. Relais (16) nach Anspruch 1,
dadurch gekennzeichnet, dass
die bewegliche Klappeneinrichtung (33) aus Kunststoff hergestellt ist.
- à clapet mobile (33) puisse effectuer une rotation par rapport audit cadre (25) sous l'action d'un courant d'huile, au moins une portion de ladite surface du dispositif à clapet mobile (33) sensible à la présence de courants d'huile étant également réductible, **caractérisé en ce que** des fractures préalables (43, 44) sont formées dans ledit élément plat (37) de façon à constituer ladite surface réductible, lesdites fractures préalables (43, 44) formant au moins une portion détachable (45).
2. Relais (16) selon la revendication 1, **caractérisé en ce que** ledit dispositif à clapet mobile (33) comporte un support tubulaire (40) à l'intérieur duquel un contre poids (41) peut être inséré.
3. Relais (16) selon la revendication 1, **caractérisé en ce que** des guides mutuellement opposés (46) pour le coulissement des extrémités (36) dudit pivot (35) sont formés dans ledit cadre (25), chaque guide (46) se terminant par un siège (47) qui est adapté pour l'insertion par pression desdites extrémités (36).
4. Relais (16) selon la revendication 1, **caractérisé en ce que** ledit dispositif à clapet mobile (33) est fabriqué à partir de plastique.

Revendications

1. Relais de Buchholz (16), comprenant, afin d'être immergé dans un bain d'huile, un cadre de support (25) pour des interrupteurs magnétiques (29) destinés à fermer des circuits mis en fonctionnement par des dispositifs mobiles (30, 31), dont au moins un est du type flotteur (32) et au moins un est du type à clapet (33) associé de manière rotative avec ledit cadre (25), dans lequel ledit dispositif à clapet mobile (33) est indépendant desdits flotteurs (32) et comprend un élément plat (37) prévu avec un pivot (35) associé de manière rotative avec ledit cadre (25) au moyen de ses extrémités (36), ledit dispositif à clapet mobile (33) ayant également une surface sensible à la présence de courants d'huile de sorte que ledit dispositif

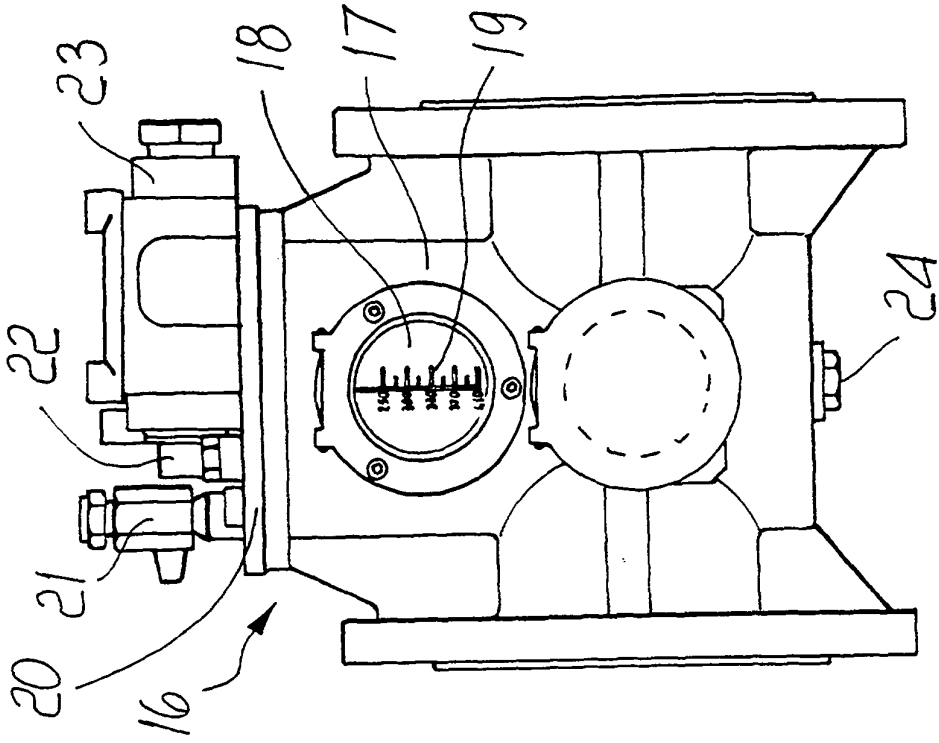

FIG. 2

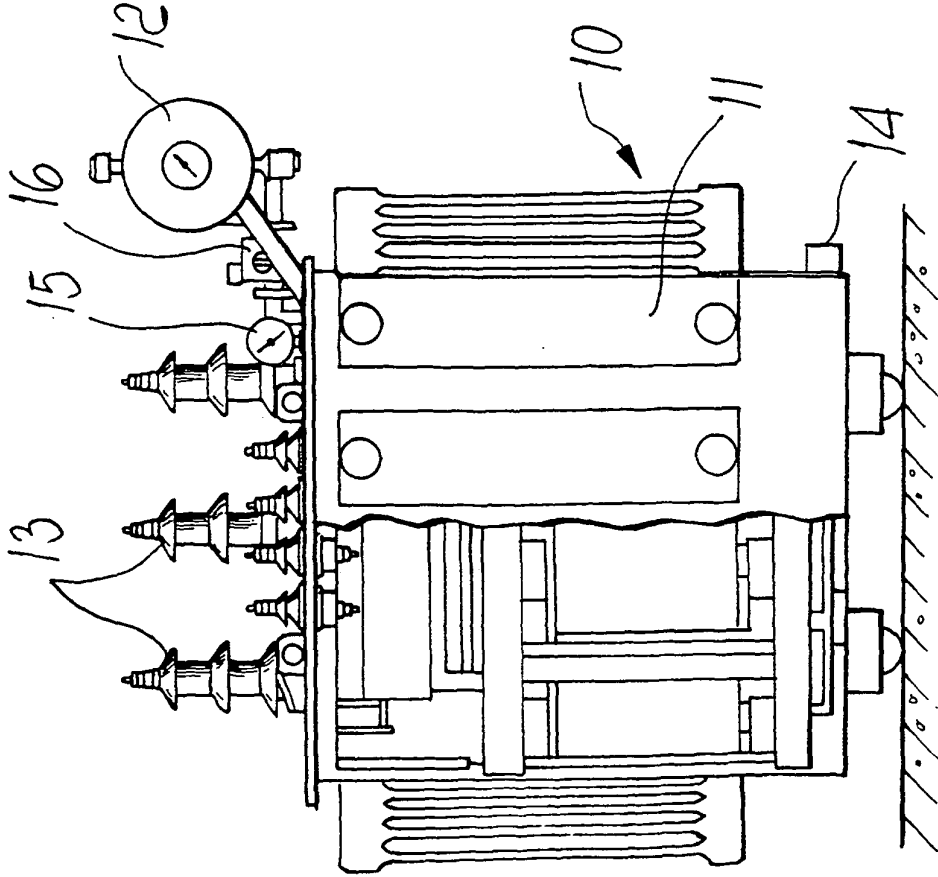

FIG. 1

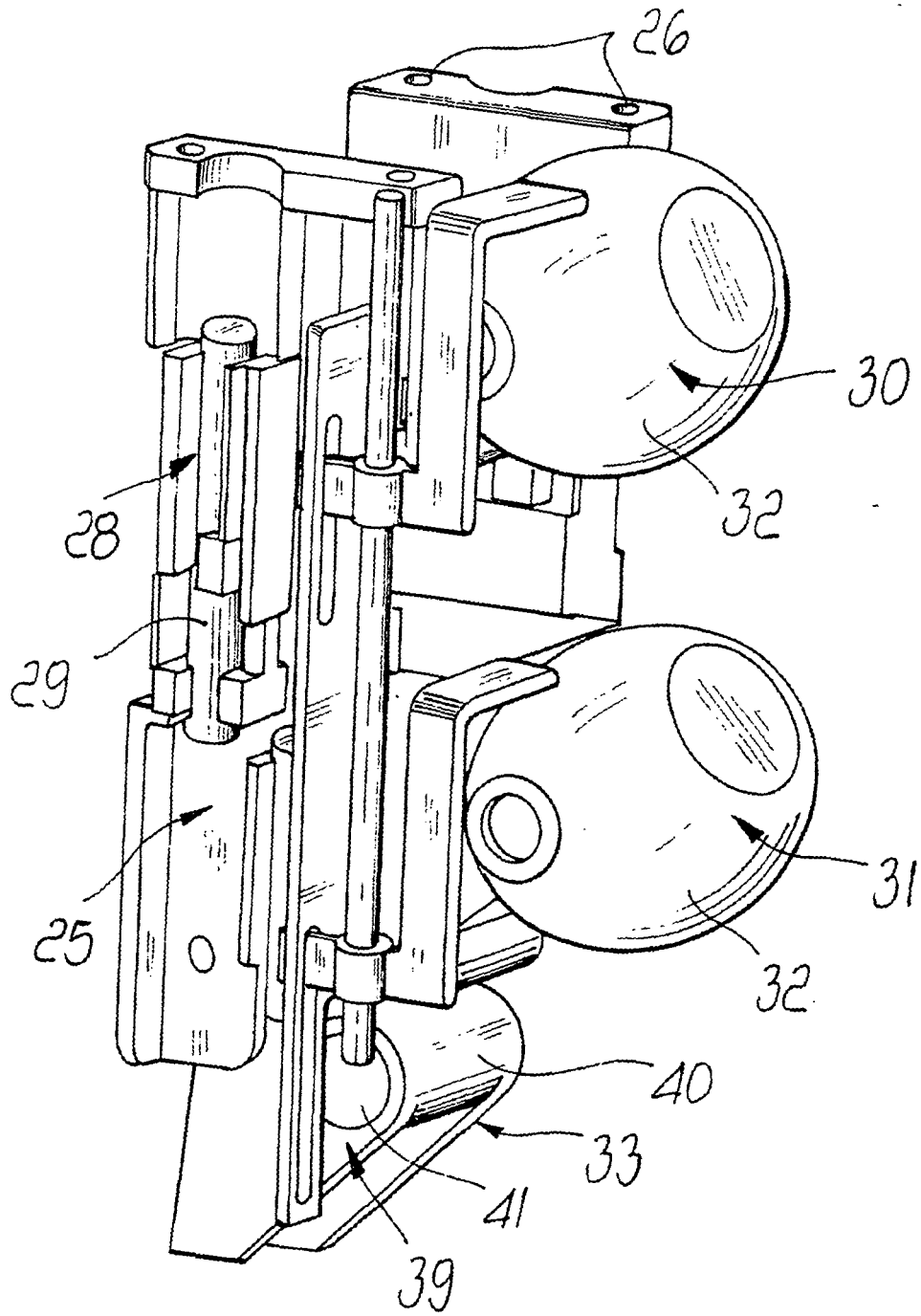
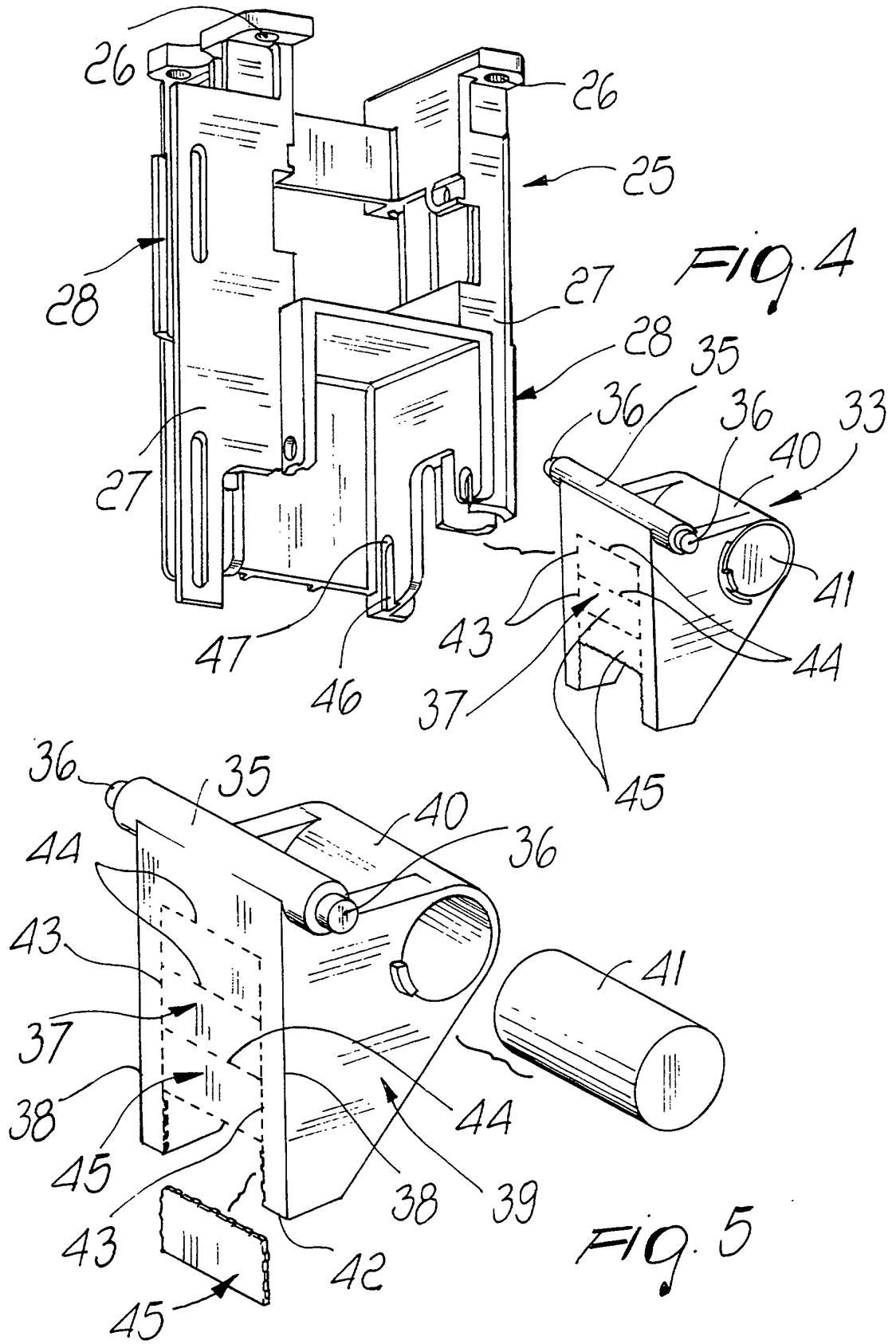

FIG. 3



REFERENCES CITED IN THE DESCRIPTION

This list of references cited by the applicant is for the reader's convenience only. It does not form part of the European patent document. Even though great care has been taken in compiling the references, errors or omissions cannot be excluded and the EPO disclaims all liability in this regard.

Patent documents cited in the description

- DE 3248275 A [0019]