

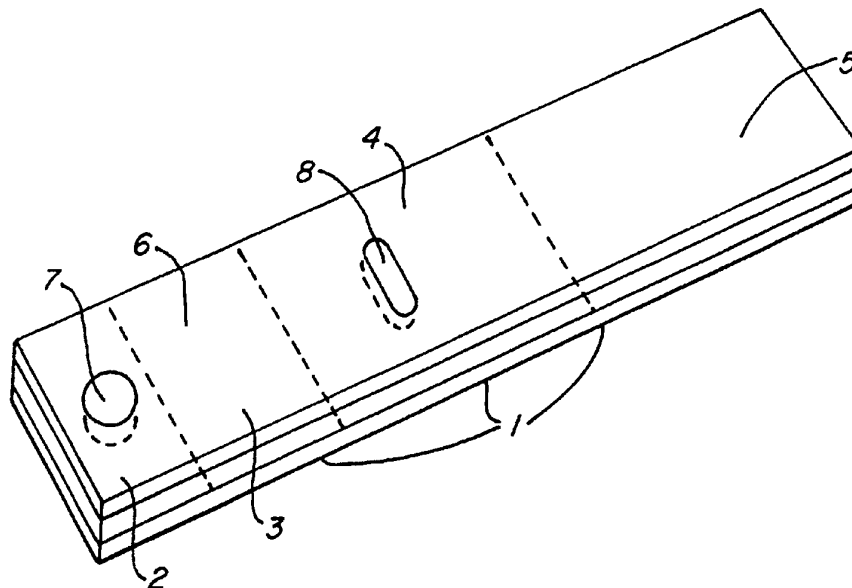

## INTERNATIONAL APPLICATION PUBLISHED UNDER THE PATENT COOPERATION TREATY (PCT)

<p>(51) International Patent Classification <sup>5</sup> : G01N 21/00, 31/00, 33/53, 33/537, 33/538, 33/541, 33/543, 33/545, 33/546, 33/553, 33/554, 33/563, C12Q 1/00, 1/70</p>	A1	<p>(11) International Publication Number: <b>WO 94/29696</b> (43) International Publication Date: 22 December 1994 (22.12.94)</p>
<p>(21) International Application Number: PCT/US94/05870 (22) International Filing Date: 24 May 1994 (24.05.94) (30) Priority Data: 08/075,085 9 June 1993 (09.06.93) US (71) Applicant: QUIDEL CORPORATION [US/US]; 10165 McKellar Court, San Diego, CA 92121 (US). (72) Inventors: MILLER, Steven, Paul; 12557 Maestro Court, San Diego, CA 92130 (US). QUIWA, Nol; 1130 Manzana Way, San Diego, CA 92139 (US). PRONOVOST, Allan, D.; 22864 Salmon River Road, San Diego, CA 92129 (US). (74) Agent: HESLIN, James, M.; Townsend and Townsend Khourie and Crew, Steuart Street Tower, 20th floor, One Market Plaza, San Francisco, CA 94105 (US).</p>	<p>(81) Designated States: CA, JP, European patent (AT, BE, CH, DE, DK, ES, FR, GB, GR, IE, IT, LU, MC, NL, PT, SE).  Published <i>With international search report.</i></p>	

(54) Title: ANTIGEN-SPECIFIC ONE-STEP ASSAYS



## (57) Abstract

A method and a device for determining, in a biological fluid sample, levels of antigen-specific immunoglobulins, said device comprising a matrix (1) defining an axial flow path, which matrix (1) has a sample receiving zone (2), a labelling zone (3) comprising a visible label bound to a first immunoglobulin-binding substance, a capture zone (4) comprising an immobilized second immunoglobulin-binding substance, and an absorbent pad (5) located sequentially downstream therein. Application of the sample to the sample receiving zone (2) results in specific binding of immunoglobulin present in the sample to labelling complex and accumulation of any antigen-specific immunoglobulin-labelling complex in the capture zone (4). The device and method are useful in determining allergen-specific IgE or other immunoglobulins specific for pathogens; and, may be used to simultaneously determine a plurality of immunoglobulins specific for different antigens or pathogens.

*FOR THE PURPOSES OF INFORMATION ONLY*

Codes used to identify States party to the PCT on the front pages of pamphlets publishing international applications under the PCT.

AT	Austria	GB	United Kingdom	MR	Mauritania
AU	Australia	GE	Georgia	MW	Malawi
BB	Barbados	GN	Guinea	NE	Niger
BE	Belgium	GR	Greece	NL	Netherlands
BF	Burkina Faso	HU	Hungary	NO	Norway
BG	Bulgaria	IE	Ireland	NZ	New Zealand
BJ	Benin	IT	Italy	PL	Poland
BR	Brazil	JP	Japan	PT	Portugal
BY	Belarus	KE	Kenya	RO	Romania
CA	Canada	KG	Kyrgyzstan	RU	Russian Federation
CF	Central African Republic	KP	Democratic People's Republic of Korea	SD	Sudan
CG	Congo	KR	Republic of Korea	SE	Sweden
CH	Switzerland	KZ	Kazakhstan	SI	Slovenia
CI	Côte d'Ivoire	LI	Liechtenstein	SK	Slovakia
CM	Cameroon	LU	Luxembourg	SN	Senegal
CN	China	LK	Sri Lanka	TD	Chad
CS	Czechoslovakia	LV	Latvia	TG	Togo
CZ	Czech Republic	MC	Monaco	TJ	Tajikistan
DE	Germany	MD	Republic of Moldova	TT	Trinidad and Tobago
DK	Denmark	MG	Madagascar	UA	Ukraine
ES	Spain	ML	Mali	US	United States of America
FI	Finland	MN	Mongolia	UZ	Uzbekistan
FR	France			VN	Viet Nam
GA	Gabon				

**ANTIGEN-SPECIFIC ONE-STEP ASSAYS**

5

**BACKGROUND OF THE INVENTION****1. Field of the Invention**

10 The present invention relates generally to devices and methods for the detection of immunoglobulins in biological fluids. More particularly, the present invention provides devices and methods for one-step detection of those immunoglobulins.

**15 2. Description of the Background Art**

Immunoglobulins are proteins, produced by plasma cells, which are related to a wide variety of biological functions. For example, immunoglobulins contribute to immune clearance of foreign antigens. During infection with a pathogen, immunoglobulins are produced to antigens of the pathogen as a means of host defense. The production of immunoglobulins to the pathogen subsides following resolution of the infection. Two immunoglobulins, IgG and IgM, are the most abundant immunoglobulins produced in response to an infection. IgM is typically produced first, provides the initial defense against the pathogen, and is quickly cleared from the host. IgG is produced later during the course of the infection and provides a more long lasting defense against the pathogen. Another immunoglobulin, IgA, is secreted by the host to provide a surface defense mechanism.

25 Detecting the presence of an immunoglobulin in a biological fluid which reacts with a pathogen-specific antigen can aid or confirm a diagnosis of infection by the pathogen. For example, Helicobacter pylori (H. Pylori) antibody detection by antibody subclass reactivity measure against H. pylori species-specific antigens may be used as an aid in diagnosis of peptic ulcer disease, non-ulcer dyspepsia, and

chronic active gastritis. Also, detection of immunoglobulins specific for certain bacteria, such as Streptococcus pneumonia and H. pylori, indicates patient exposure to the bacteria.

5 The presence of IgM strongly suggests active or very recent infection since it is cleared quickly by the host. The presence of IgG or IgA indicates prior infection or exposure to the antigen. Monitoring levels of immunoglobulins can also detect progression or remission of disease.

10 Measurement of immunoglobulins to a specific antigen is also important for the detection of latent or sub-clinical infections. For example, rubella often produces minimal symptoms in adult women. If the woman is pregnant, however, the virus can cause severe congenital anomalies. Thus, measurement of immunoglobulins to rubella is important as a  
15 means to protect the fetus from preventable congenital defects. Often, the only means to determine whether a woman is presently infected or at risk for infection (due to low IgG levels from past infection) is the measurement of rubella specific immunoglobulins in the woman's serum. Human  
20 immunodeficiency virus (HIV) is another example of a latent virus which is detected by means of measuring host immunoglobulin to HIV specific antigens.

Several immuno-deficiency syndromes are associated with deficient production of immunoglobulins. A- $\gamma$ -  
25 globulinemia is a deficiency of IgG. These patients have low levels of IgG and recurrent infections. The diagnosis of the syndrome is made by measuring serum IgG. IgM and IgA deficiencies have also been described. The prognosis and diagnosis are similar to that of a- $\gamma$ -globulinemia.

30 Celiac disease is another disease which apparently is immunologically mediated. Celiac disease is genetically predisposed and results from the injurious effects of dietary (wheat) gluten on the mucosa of the small intestine. Abdominal symptoms with associated findings of malabsorption  
35 are the classical clinical features of the disease, but elevated levels of alpha-gliadin-specific IgA and IgG have also been associated with the disease.

Allergic reactions may also be mediated through immunoglobulins. Type I hypersensitivity reactions, such as hayfever and allergic rhinitis, are dependent upon IgE which reacts with the causative allergen. Atopic individuals have higher levels of IgE in their serum than non-atopic individuals. Also, IgE which is specific for the causative allergens is present in the patient's serum.

Identification of allergens to which a patient is sensitive is typically accomplished by skin tests. Small amounts of different suspected allergens are subcutaneously injected into the patient. Typically, patients respond with a "wheal and flare" to allergens responsible of the patient's symptoms. Occasionally however, the small amount of allergen injected into a patient is sufficient to produce anaphylaxis and even death. Thus, in addition to the discomfort of the injections more serious side effects can occur.

Myelomas are plasma cell malignancies which typically produce immunoglobulins. The diagnosis of myeloma is generally made by plasma electrophoresis of the patient's serum. The effect of treatment of the myeloma can be monitored by serial measurement of the immunoglobulin produced by the malignant plasma cells.

From the above examples, it is clear that detection of the presence or levels of immunoglobulins in biological fluids, such as serum, is medically important and desirable. Because of the relatively low concentrations of antigen-specific immunoglobulins in biological fluids, it is difficult to detect, much less accurately quantitate, important immunoglobulins in biological fluids. For example, IgE is typically present in human serum at concentrations only on the order of  $10^{-6}$  to  $10^{-4}$  mg/ml. Because normal IgE levels are too low, detection of elevated levels of IgE antibodies can be difficult although useful for safely diagnosing allergic conditions. Allergen specific IgE levels are generally lower than total IgE levels in human serum.

Complex means have been developed to detect and quantitate immunoglobulins in biological fluids such as serum.

For example, serum immunoelectrophoresis is the standard assay to detect the presence of myeloma proteins in patients having multiple myeloma. In this procedure, after separation of the serum from whole blood the serum is placed on a gel and subjected to electrophoresis. Following differential migration of serum proteins on the gel, the proteins are identified by immunoprecipitation. While accurate, the technique is cumbersome, time consuming, and not amenable to rapid use in the clinician's office.

Other methods for identifying and quantifying immunoglobulins in serum have also been developed, e.g., U.S. Patent No. 4,861,711 describes lateral flow assays wherein the lateral flow provides chromatographic behavior. European patent application 306,772 describes a lateral flow device having a chromatographic medium separating the sample receiving zone and the capture zone. British patent application 2,204,398, U.S. Patent No. 4,168,146, and European application 276,152 all describe different lateral flow assay devices. For example, U.S. Patent No. 4,943,522 describes lateral flow non-bibulous assay protocols for the identification of, e.g., HLA tissue types, blood groups, and antigens of infectious organisms.

None of the above references describe means for serum immunoglobulin measurement that can be accomplished accurately, easily, and rapidly in a one step procedure wherein low levels of antigen and immunoglobulin subclass specific antibodies are detected in serum the presence of all immunoglobulin in that serum. Because the measurement of serum immunoglobulins is becoming increasingly important in patient care, especially as related to the development of use of rapid one step assays, a need exists for an easy and accurate method of detecting serum immunoglobulins. The present invention fulfills these and other needs.

#### SUMMARY OF THE INVENTION

The present invention provides devices and methods for detection of the presence, absence, or amount of

immunoglobulins reactive with an antigen in a biological fluid sample. The biological fluid sample may be whole blood, plasma, serum, nasal secretions, sputum, saliva, urine, sweat, transdermal exudates, cerebrospinal fluid, or the like.

5 Immunoglobulins of different subclasses of isotypes or reactive with different antigens may be detected simultaneously or individually in some embodiments of the present invention. Multiple different antigen-specific immunoglobulins may be detected from a single specimen.

10           Devices of the present invention generally include a means for labelling the immunoglobulins having a labelling complex comprising a visible label bound to a first immunoglobulin-binding substance; a matrix defining an axial flow path, said matrix having a sample receiving zone, a capture zone located downstream from the sample receiving zone, and an absorbent zone located downstream from the capture zone; and a second immunoglobulin-binding substance immobilized in the capture zone. Application of the sample to the sample receiving zone results in specific binding of immunoglobulin present in the serum to labelling complex in the labelling means and accumulation of antigen-specific immunoglobulin-labelling complex in the capture zone based on the amount of antigen-specific immunoglobulin initially present in the serum sample. The accumulation of the antigen-specific immunoglobulin-labelling complex in the capture zone provides a means to identify the presence of antigen-specific immunoglobulins in the sample.

20           Methods of the present invention generally comprise applying the sample to a sample receiving zone on a matrix having a flow path to a capture zone located downstream from the sample receiving zone, wherein the sample also flows through a means for labelling the immunoglobulins that contains a labelling complex comprising a visible label bound to a first immunoglobulin-binding substance, a second immunoglobulin-binding substance is immobilized in the capture zone, and at least one of the first immunoglobulin-binding substances and the second immunoglobulin-binding substances is

35

the antigen; and observing the accumulation of visible label within the capture zone as a result of immunoglobulin specific for the antigen present in the sample specifically binding to the labelling complex in the labelling means and the resulting immunoglobulin-labelling complex flowing into and being captured within the capture zone.

#### BRIEF DESCRIPTION OF THE FIGURES

Fig. 1 illustrates a device for the detection, in a patient serum sample, of immunoglobulins specific for a single antigen having a labelling zone defined by the axial flow path of the matrix.

Fig. 2 illustrates a device for the detection, in a patient serum sample, of immunoglobulins specific for a single antigen having a sample receiving pad through which the serum sample is applied to the sample receiving zone.

Fig. 3 illustrates a device for the simultaneous detection, in a patient serum sample, of immunoglobulins specific for five different antigens.

#### DESCRIPTION OF SPECIFIC EMBODIMENTS

The present invention provides devices and methods for use in determining, in a biological fluid sample, the presence, absence, levels or type(s) of immunoglobulins which are reactive with an antigen. As used hereinafter, the phrase "immunoglobulins which are reactive with an antigen" is meant to refer to polypeptides which specifically bind to epitopes of the antigen. This property is also referred to as antigen-specific. The immunoglobulins may be antibodies of any isotype, such as IgE, IgG, or IgM, Fab fragments, F(ab')<sub>2</sub> fragments, Fab' fragments, or the like. Hereinafter, the phrase "target immunoglobulin" will be meant to refer to immunoglobulins in the biological fluid sample which are to be measured by devices or methods of the present invention. Also provided are devices and methods for determining, in a biological sample, the level of all immunoglobulins of a specific isotype. "Levels of immunoglobulins" is meant to



refer to the concentration of immunoglobulins in the serum of the patient as expressed in concentration (mg/ml, molarity, etc.) dilution or titer, or by the assay response in quantal (yes, no; present, absent; or quantitative terms (units, classes, etc.) or through measurement of color response by instrumentated means (reflectance, transmission, etc.). Typically, the biological fluid will be serum although other fluids such as saliva, cerebrospinal fluid, transdermal exudate, whole blood, sweat sputum, nasal secretions, urine or the like may be employed.

Generally, the devices and methods of the present invention employ lateral flow assay techniques as generally described in U.S. Patent Nos. 4,943,522; 4,861,711; 4,857,453; 4,855,240; 4,775,636; 4,703,017; 4,361,537; 4,235,601; 4,168,146; 4,094,647; co-pending application U.S.S.N. 07/639,967, European Patent Application Nos. 451,800; 158,746; 276,152; 306,772 and British Patent Application No. 2,204,398; each of which is incorporated herein by reference.

The devices employ a means for labelling the suspected immunoglobulins in the serum sample with a labelling complex, and a matrix with a sample receiving zone and a capture zone. Because of the construction of the present invention, application of the patient sample in the sample receiving zone results in specific binding of immunoglobulin present in the serum to labelling complex and accumulation of antigen-specific immunoglobulin-labelling complex in the capture zone based on the amount of antigen-specific immunoglobulin initially present in the serum sample.

The means for labelling the immunoglobulins is typically a labelling zone. The labelling zone is on the matrix which defines a flow path. The labelling zone is located between the sample receiving zone and the capture zone in the sample flow path. Thus, a serum sample placed in the sample receiving zone will flow through the labelling zone before contacting the capture zone.

Alternatively, the labelling means may be a sample receiving pad. During use of the assay device, the sample

receiving pad will generally contact and be on the surface of the sample receiving zone. The sample receiving pad may be affixed in position on the assay device or may be placed upon the surface of the sample receiving zone prior to use.

5 Because the labelling complexes are contained within, but not immobilized to, the sample receiving pad, the labelling complexes may be solubilized in the serum sample and bind to target immunoglobulins in the serum.

10 The labelling means contain labelling complexes that specifically bind to immunoglobulins in the patient sample. The labelling complexes are comprised of a visible label bound to a first immunoglobulin-binding substance. The first immunoglobulin-binding substance may be, e.g., an anti-immunoglobulin antibody or fragment thereof, or an antigen  
15 which is specifically bound by the immunoglobulin. Generally, the first immunoglobulin binding substance is an antigen which is specifically bound to the immunoglobulin to be detected in the sample. For example, in the case of detecting allergen-specific IgE, the first immunoglobulin binding substance will  
20 be the allergen. This provides a convenient means for allergens to which the patient has elevated levels of IgE. The labelling complex is not immobilized to the labelling zone so that the serum sample may solubilize or otherwise remove the labelling complexes into the fluid sample.

25 A variety of visible labels may be bound to the first immunoglobulin-binding substance. The labels may be soluble or particulate and may include dyed immunoglobulin binding substances, simple dyes or dye polymers, dyed latex beads, dye-containing liposomes (such as described in U.S.  
30 Patent No. 4,695,554, incorporated herein by reference), dyed cells or organisms, or metallic, organic, inorganic, or dye sols. The labels may be bound to the immunoglobulin-binding substance by a variety of means which are well known in the art such as described in U.S. Patent Nos. 4,863,875 and  
35 4,373,932, each of which is incorporated herein by reference.

Because the labelling complexes contain an immunoglobulin-binding substance and the labelling complexes

are solubilized or dispersed into the patient serum sample, target immunoglobulins in the sample which react with the immunoglobulin-binding substance are contacted and bound by the labelling complexes prior to entering the capture zone.

5 In this manner, the serum target immunoglobulin molecules are labelled. If any of the labelled serum target immunoglobulin molecules are retained in the capture zone of the device, the label provides a means for detection.

10 The matrix of the assay device will typically be capable of non-bibulous lateral flow. By "non-bibulous lateral flow" is meant liquid flow in which all of the dissolved or dispersed components of the liquid are carried at substantially equal rates and with relatively unimpaired flow laterally through the membrane, as opposed to preferential  
15 retention of one or more components as would occur, e.g., in materials capable of adsorbing or imbibing one or more components.

One non-bibulous matrix material is the high density polyethylene sheet material manufactured by Porex Technologies  
20 Corp. of Fairburn, Georgia, USA. The membrane has an open pore structure with a typical density, at 40% void volume, of 0.57 gm/cc and an average pore diameter of 1 to 250 micrometers, the average generally being from 3 to 100 micrometers. The optimum pore diameter for the membrane for  
25 use in the invention is about 10 to about 50  $\mu\text{m}$ . The membranes are from a few mils (.001 in) to several mils in thickness, typically in the range of from 5 or 10 mils and up to 200 mils. The membrane may be backed by a generally water impervious layer, or may be totally free standing. Other non-  
30 bibulous membranes, such as polyvinyl chloride, polyvinyl acetate, copolymers of vinyl acetate and vinyl chloride, polyamide, polycarbonate, nylon, glass fiber, orlon, polyester polystyrene, and the like, or blends can also be used.

Bibulous materials, such as untreated paper,  
35 nitrocellulose, derivatized nylon, cellulose and the like may also be used following processing to provide non-bibulous flow. Blocking agents may block the forces which account for

the bibulous nature of bibulous membranes. Suitable blocking agents include whole or derivatized bovine serum albumin or albumin from other animals, whole animal serum, casein, and non-fat dry milk.

5           The matrix comprises at least two zones, a sample receiving zone and a capture zone. The size and shape of the matrix are not critical and may vary. The matrix defines a lateral flow path. In some embodiments of the present invention, the flow path may be axial. In other embodiments  
10 the flow path may be circular, radial or combine radial or circular and lateral flow in which the advancing margin of the sample approximates a circle or a fan. A circular flow path is particularly useful for the simultaneous measurement of immunoglobulins which react with several different antigens.

15           When a sample is placed on the sample receiving zone it may flow by non-bibulous lateral flow to the capture zone. When the labelling means is a labelling zone, the matrix comprises three zones. The labelling zone is located on the matrix so that after application of the sample to the sample  
20 receiving zone, the sample flows through the labelling zone prior to flowing into the capture zone.

          The sample receiving zone provides a means for applying the sample to devices of the present invention. The flow of the sample begins in the sample receiving zone.  
25 Generally, the sample receiving zone should have a low analyte retention rate. Treatment of the sample receiving zone to immobilize a protein-blocking reagent on the surface, if necessary, will typically provide low retention properties. This treatment also provides increased wettability and wicking  
30 action to speed the downstream flow of the serum sample. The sample receiving zone may also serve as a means for filtering particulates from the sample.

          The capture zone typically contacts the sample receiving zone, or, if present, the labelling zone. A second  
35 immunoglobulin-binding substance is immobilized on the capture zone. The second immunoglobulin-binding substance may be, e.g., an anti-immunoglobulin antibody or fragment thereof, or

an antigen which is specifically bound by the immunoglobulin. Typically, the second immunoglobulin-binding substance will be an anti-immunoglobulin antibody and the first immunoglobulin-binding substance will be the labelled antigen which

5 specifically reacts with the sample immunoglobulin to be tested. In this manner, the first immunoglobulin-binding substance will bind the  $F_v$  portion of the sample immunoglobulin while the second immunoglobulin-binding substance will bind the  $F_c$  portion of the sample

10 immunoglobulin. Like the first immunoglobulin-binding substance, the second immunoglobulin-binding substance specifically binds the immunoglobulins to be detected in the sample. As the target immunoglobulins in the sample contact the capture zone, they bind to the second immunoglobulin-

15 binding substance and are retained in the capture zone. Since target immunoglobulins present in the sample have been labelled by the labelling complexes, retention of target immunoglobulins in the capture zone is detected by observation of visible label accumulation. The accumulation of visible

20 label may be assessed either visually or by optical detection devices, such as reflectance analyzers, video image analyzers and the like. The accumulation of visible label can be assessed either to determine the presence or absence of label in the capture zone or the visible intensity of accumulated

25 label which may be correlated with the concentration or titer (dilution) of antigen-specific target immunoglobulins in the patient sample. The correlation between the visible intensity of accumulated label and antigen-specific immunoglobulin concentration may be made by comparison of the visible

30 intensity to a reference standard. Optical detection devices may be programmed to automatically perform this comparison by means similar to that used by the Quidel Reflective Analyzer, Catalog No. QU0801 (Quidel Corp., San Diego, CA). Visual comparison is also possible by visual evaluation of the

35 intensity and a color key such as used in the Quidel Total IgE Test Catalog No. 0701 (a multi-step ELISA assay). Thus, antigen-specific immunoglobulin levels may be determined.

The capture zone is often contacted by a bibulous absorbent zone. The absorbent zone is located downstream from the capture zone. The absorbent zone is a means for removing excess sample and unbound labelling complexes from the matrix of the device. Generally, the absorbent zone will consist of an absorbent material such as filter paper, a glass fiber filter, or the like.

The devices and methods of present invention find particular utility for the diagnosis of allergic conditions. In this embodiment, specific allergens serve as the antigens. Patients who are not allergic to a particular allergen will have very low, if even detectable, levels of IgE specific for the allergen. Elevated antigen-specific IgE levels are typically present only in the serum of patients allergic to the allergen. Measurement of antigen-specific IgE levels in a patient's serum can provide evidence that a patient is allergic to the specific antigen.

When testing for allergen-specific IgE, at least one of the immunoglobulin-binding substances will be the allergen. Both immunoglobulin-binding substances may be the allergen. In this manner any immunoglobulin which specifically binds the allergen will be retained in the capture zone and detected.

To determine total IgE levels, the first and second immunoglobulin-binding substances will typically be anti-IgE antibodies. These antibodies will bind all IgE molecules, not just those specific for a particular allergen. Alternatively, the immunoglobulin-binding substances may be Fab fragments, F(ab')<sub>2</sub> fragments Fab' fragments or the like.

Particular antibodies against antigens which might be detected by the methods and devices of the present invention include grasses, e.g. bermuda grass, timothy grass, perennial rye grass, and the like; dander, such as dog dander, cat dander, and the like; foods, e.g., egg, milk, soybean, apples, peanuts, wheat, strawberries, shellfish, and the like; insect venom, such as mosquito venom, wasp venom, bee venom, and the like; trees, such as elm, oak, acacia, and the like; bacteria such as Streptococcus pneumonia, Helicobacter pylori,

and the like; viruses such as hepatitis virus, and the like; flowers, such as marigold, sunflower, and the like; and weeds, such as pigweed, ragweed, Russian thistle, and the like. This list is only partial and those of skill will readily appreciate that immunoglobulins to other allergens could be detected by the methods and devices of the present invention.

Non-IgE antibodies to allergens may also be detected and quantified by the devices and methods of the present invention. Detection of these antibodies is particularly useful for assessing the efficacy of allergen desensitization. Because desensitization to an allergen results from production of IgG and IgM specific for the allergen, determination of allergen-specific IgG and IgM in a patient's serum can assess the effectiveness of desensitization prior to a direct patient challenge with allergen. Also, serial determinations of allergen-specific IgG or IgM provide a method for assessing the duration of effective desensitization.

When assessing either the efficacy or duration of desensitization, one immunoglobulin-binding substance will be the allergen or an epitope thereof. The other immunoglobulin-binding substance will be either anti-IgG or anti-IgM. Typically the level of IgG or IgM which results with the allergen will be determined.

Detection of non-IgE antibodies to specific antigens is also a useful for the assessment of passive immunity. Long-term immunoglobulin treatment has been used for the treatment of different diseases. Because antibodies are naturally catabolized, passive immunization requires repeated doses. By using the devices and methods of the present invention, the presence and/or levels of antigen-specific antibodies can be easily determined and the need for additional treatment assessed. For example,  $\gamma$ -globulin prophylaxis against hepatitis A can be monitored in travellers in endemic regions. Thus, repeat dosage schedules can be optimized.

In some embodiments of the present invention a plurality of immunoglobulins reactive with a plurality of

different antigens may be simultaneously detected. Antigen-specific antibodies which may be detected by the present invention include measurement of IgA, IgG, or IgM to  $\alpha$ -gliadin for celiac disease, H. pylori, Epstein Barr Virus viral capsid antigen, Chlamydia species, Herpes simplex virus, cytomegalovirus, Toxoplasma species, Rubella virus, Varicella Zoster virus, Lyme disease, or Mycoplasma pneumoniae. The devices comprise at least one means for labelling the immunoglobulins, each labelling means having a matrix defining a flow path, said matrix having a sample receiving zone, a plurality of capture zones located downstream from the sample receiving zone, and an absorbent zone located downstream from the capture zones; a labelling complex comprising a visible label bound to a first immunoglobulin-binding substance; and a plurality of second immunoglobulin-binding substances, each immobilized in a separate capture zone; whereby application of a patient serum sample to the sample receiving zone results in specific binding of immunoglobulin present in the serum to labelling complexes in the labelling means and accumulation of antigen-specific immunoglobulin-labelling complex in the different capture zones based on the amount of different antigen-specific immunoglobulins initially present in the serum sample.

The devices may have one or more labelling means. Each of the labelling means may have the same or different labelling complexes. When different labelling complexes are employed, the labelling complexes may differ in the visible label, the immunoglobulin-binding substance or both. The devices may also incorporate identical labelling complexes in the different labelling means. Alternatively, the devices may have a single labelling means with a single or different labelling complexes. Typically, each labelling means will be a labelling zone located on the matrix between the sample receiving zone and at least one capture zone.

The different antigens are generally used as either the first or second immunoglobulin-binding substances. Use of



the different antigens provides a means to differentiate and detect and/or quantitate different antigen-specific immunoglobulins in the serum samples. In this embodiment, the antigens are most conveniently employed as second  
5 immunoglobulin-binding substances and immobilized in the different capture zones. Each capture zone will typically contain only one specific antigen. Anti-immunoglobulin antibodies (e.g., anti-IgG or Anti-IgM) are generally employed as the first immunoglobulin-binding substances. The choice of  
10 labels is not critical and may vary.

Devices for the simultaneous detection of immunoglobulins to several different antigens are particularly useful in screening populations for past exposure to microbial pathogens. For example a single device could provide rapid  
15 screening of past exposure to HIV, syphilis, and hepatitis B in community based sexually transmitted disease clinics. Office screening of pregnant women for past exposure to *Toxoplasma gondii*, Rubella virus, cytomegalovirus, herpes simplex virus, and *Treponema pallidum* to identify fetuses at  
20 risk for TORCHES syndrome or *Helicobacter pylori*, as related to peptic ulcer disease or stomach cancer could be accomplished by the present invention. Those of skill in the art will readily appreciate that simultaneous screening as described above may be useful in a wide variety of other  
25 clinical situations for a variety of pathogens or allergens.

Also provided are assays for determining the present absence, or amount at immunoglobulins specific for an antigen in a biological fluid sample. The sample will typically be serum although other biological fluids are acceptable. A  
30 sample is applied to a sample receiving zone on a matrix. The matrix has a flow path to a capture zone located down stream from the sample receiving zone.

Prior to contacting the capture zone, the sample flows through a means for labelling the immunoglobulins with a labelling complex comprised of a visible label bound to a  
35 first-immunoglobulin binding substance. The first

immunoglobulin-binding substance will bind any target immunoglobulins in the sample.

The capture zone has a second immunoglobulin-binding substance immobilized therein. At least one of the first  
5 immunoglobulin-binding substance and the second immunoglobulin-binding substance is the antigen to which the target immunoglobulins are specific. The antigen-specific immunoglobulins in the sample serve as a link between the visible label of the first immunoglobulin-binding substance  
10 and the immobilized second immunoglobulin-binding substance. Thus, when antigen-specific target immunoglobulins are present in the sample, the visible label will be retained in the capture zone. In this manner the presence of antigen-specific immunoglobulins in the sample can be detected by observing the  
15 accumulation of visible label in the capture zone.

Typically the matrix has an axial flow path and the labelling means is contacted after the sample has been applied to the matrix, but prior to contacting the capture zone. Alternatively, the sample may be contacted with the labelling  
20 means prior to application to the matrix. Often the matrix will be non-bibulous.

These methods are particularly useful for the detection of allergen-specific IgE in a patient's serum. At least one of the immunoglobulin-binding substances will be the  
25 allergens and the other will be anti-IgE.

Total isotopic immunoglobulin concentrations may also be determined by the methods of the present invention. In this embodiment, both the first and the second immunoglobulin-binding substances are anti-isotype antibodies.  
30 For example, if total IgE concentration is to be determined, anti-IgE antibodies serve as both immunoglobulin-binding substances.

The methods are also useful for detecting pathogen specific immunoglobulins in patient serum. For example, the  
35 presence of IgG or IgM to Helicobacter pylori can confirm the presence of peptic ulcer disease. Monitoring Helicobacter pylori-specific immunoglobulin concentration by the present

methods also provides a convenient means to assess the efficacy of therapy and resolution of disease. When possible, the target immunoglobulin level is determined prior to treatment and then serially thereafter. Decreasing immunoglobulin levels indicate that the condition is improving while rising or stable immunoglobulin levels indicate persistent infection and disease. Similar assays may be performed to detect immunoglobulins specific for the causative agent of Lyme Disease, *Borrelia burgdorferi*. Many other pathogens, such as *Toxoplasma gondii*, Cytomegalovirus, Herpes Simplex virus, *Treponema pallidum*, *Chlamydia trachomatis*, *Mycoplasma pneumonia* and Rubella virus may be conveniently detected and monitored by these assays.

The assays of the present invention are also useful for simultaneously determining the presence, absence or amounts of a plurality of immunoglobulins in a biological fluid sample which are specific for different antigens. A single sample is analyzed. The sample flows to a plurality of capture zones. Prior to contacting the capture zones the sample flows through one or more labelling means. Each labelling means contains at least one first immunoglobulin-binding substance. A single first immunoglobulin-binding substance may be employed. In this case, the first immunoglobulin-binding substance must be capable at binding to all target immunoglobulins to be detected. Alternatively, a plurality of first immunoglobulin-binding substances may be employed. As noted above, the first immunoglobulin-binding substance will be a labelled antigen which specifically reacts the sample immunoglobulin to be detected.

Typically a different antigen is immobilized in each capture zone. In this way, observation of each capture zone provides a means to differentiate and identify target immunoglobulins specific for different antigens in the fluid sample.

The accumulation of label in the capture zone may be visually compared to a reference standard such as a color key to determine the level of antigen-specific immunoglobulins in

the sample. This may also be done by an optical device such as a reflectance analyzer or a videometric quantitation system.

5 One particularly useful aspect of the present invention is the detection of immunoglobulins specific for different blood groups in a serum sample. By "blood group antigen", it is meant an antigen present in the surface of human blood cells. Such blood group antigens include those of the ABO system, the Rh system, other minor determinants, and  
10 the like. The sample may be applied to the sample receiving zone and flow into a plurality of labelling zones. A different labelled blood group antigen would be present in each labelling zone. As the sample flowed through each labelling zone, immunoglobulins specific for each blood group  
15 antigen would bind the antigen. The immunoglobulin-blood group antigen complexes would flow into the capture zone and bind an immunoglobulin-binding substance immobilized in the capture zone. If immunoglobulins specific for a specific blood group antigen are present in the sample, label will be  
20 retained in the corresponding capture zone.

The present invention may also be performed in a competitive format. In one aspect, the labelling zone  
complexes may be labelled antigen. The capture zone contains immobilized antigen-specific antibody. As the sample flows  
25 into the labelling zone, the antigen specific immunoglobulins in the sample will bind the labelled antigen. As the sample flows into the capture zone, the immobilized antibody will compete for binding to the labelled antigen with the  
immobilized antibody. The quantity of labelled antigen  
30 retained in the capture zone will be inversely proportional to the quantity of antigen specific immunoglobulins in the sample.

Alternatively, the labelling zone may contain labelled antigen-specific immunoglobulins in place of the  
labelling complexes. When the fluid sample contacts the  
35 labelling zone, the labelled antigen-specific immunoglobulins are mixed in the fluid and carried to the capture zone. The

labelled antigen-specific immunoglobulins can then bind to the immobilized antigen in the capture zone. If the fluid sample contains antigen-specific immunoglobulins (which have not been labelled), the labelled and unlabelled immunoglobulins will compete for antigen binding in the capture zone. If the fluid sample does not contain antigen-specific immunoglobulins, the labelled immunoglobulins will not be inhibited from binding with the antigen and the label color in the capture zone will be of maximum intensity. If unlabelled antigen-specific immunoglobulins are present in the fluid sample, some antigens will be bound by unlabelled antibodies and the color intensity of the retained label will be decreased. The color intensity of the retained label will diminish as the concentration of antigen-specific immunoglobulins in the sample increases. The level of antigen-specific immunoglobulins in a sample can then be determined by comparing the color intensity in the capture zone with predetermined reference standards as above.

In another aspect, the labelled antigen-specific immunoglobulins may be bound to antigens in the capture zone. If antigen-specific immunoglobulins are in the biological fluid sample, the labelled immunoglobulins will be displaced from the immobilized antigens and the color intensity of the capture zone will decrease as the fluid sample contacts the capture zone. The color change can be compared to reference standards to determine the level of antigen-specific immunoglobulins in the sample.

As in the non-competitive format, any of the competitive formats may detect multiple sample immunoglobulins specific for different antigens. The different antibodies may be detected by means of different colored labels. In some embodiments different capture zones will be employed for each different antigen-specific antibody to be detected. Alternatively, different antigen-specific antibodies may be detected in a single capture zone if a combination of the different colored labels can be distinguished from the individual labels, as with a reflectance analyzer.

Referring now to Figure 1, one embodiment of a device constructed according to the principles of the present invention is shown. The device is able to detect the presence of allergen-specific IgE in a patient's serum.

5           The device comprises a matrix 1 capable of non-bibulous lateral flow. The matrix 1 is divided into four zones. A sample receiving zone 2 is located at one end of the matrix 1. Contacting the sample receiving zone 2, and defined by an axial flow path is a labelling zone 3. A labelling  
10 complex of a visible label and a first IgE-binding substance, typically the allergen, is present in the labelling zone 3. Contacting and downstream of the labelling zone 3 is a capture zone 4. Antigens from the suspected allergen are immobilized on the capture zone 4 as well as in the labelling complex. In  
15 the illustrated embodiment an absorbent zone 5 is positioned downstream of the capture zone 3.

A solid top 6 covers the matrix 1. The matrix 1 and the solid top 6 are not in contact in the central portions of the matrix 1 so that fluid samples may flow from the sample  
20 receiving zone 2 downstream to the absorbent zone 5. The solid top 6 has a sample receiving well 7 located over the surface of the sample receiving zone 2 and an result window 8 located over the capture zone 4.

25 Patient samples are placed on the sample receiving zone 2 through the sample receiving well 7. The non-bibulous nature of the matrix 1 allows free flow of samples placed on the sample receiving zone 2. When a patient sample is placed on the sample receiving zone 2, it will flow into the labelling zone 3. The labelling complex present in the  
30 labelling zone 3 dissolves in the sample. The IgE-binding substance in the labelling complex will bind IgE in the serum sample, thus labelling allergen-specific IgE in the sample with the visible label.

35 The sample continues lateral flow into the capture zone 4. IgE specific for the suspected allergen will bind to the allergen epitopes immobilized on the capture zone 4. The visible label bound to allergen-specific IgE is also held in

the capture zone 4 by virtue of the allergen-specific IgE forming a binding link between the labelling complex and the immobilized allergen. The serum sample will continue to flow into the absorbent zone 5. Excess and unbound labelled IgE will be imbibed by the absorbent zone 5 providing a means for selectively retaining labelled allergen-specific IgE in the capture zone 4. The retained allergen-specific IgE can be detected by viewing the capture zone 4 through the result window 8. The intensity of the color of the visible label in the capture zone 4 may also provide a measure of the quantity of allergen-specific IgE in the patient's serum sample.

Figure 2 illustrates another embodiment of the present invention for the detection of allergen-specific IgE in a biological fluid sample. The device is comprised of a matrix 1 having a sample receiving zone 2, a capture zone 4, and an absorbent zone 5. The matrix 1 allows lateral flow of serum samples placed in the sample receiving zone 2. The flow path directs the sample through the capture zone 4 to the absorbent zone 5.

A solid top 6 covers the matrix 1 so that samples placed in the sample receiving zone 2 can flow to the absorbent zone 5. The solid top has a sample receiving well 7 located over the sample receiving zone 2 and a result window 8 located over the capture zone 4. The sample receiving well 7 is formed so as to accept a porous sample receiving pad 9. During use, the sample receiving pad 9 fits in the sample receiving well 7 so as to channel samples onto the sample receiving zone 2. The sample receiving pad 9 contains labelling complexes comprised of a visible label and an IgE binding substance, typically the allergen.

When the serum sample is applied to the sample receiving zone 2, the sample flows through the sample receiving pad 9 solubilizing the labelling complexes. The allergen in the labelling complexes binds allergen-specific IgE in the serum sample, thus labelling the IgE with the visible label. The labeled IgE then flows laterally to the capture zone 8. Anti-IgE specific antibody is immobilized to

the capture zone 8. As the labelled IgE contacts the anti-globulin, allergen-specific IgE will bind to the anti-globulin thereby retaining the label in the capture zone 4. Unbound components of the serum, will flow into the absorbent zone 5. Allergen-specific IgE can then be detected by observing color accumulation on the capture zone 4 through the result window 8.

Figure 3 illustrates a device for the simultaneous detection of serum immunoglobulins which are specific for different antigens. This embodiment of the present invention is particularly useful for the detection of immunoglobulins which are commonly assayed as a group.

The device comprises a matrix 1 having a sample receiving zone 2, a circular labelling zone 3, and five capture zones 4A-D. The matrix 1 provides lateral flow of serum samples placed on the centrally positioned sample receiving zone 2. The serum sample flows laterally in a circular fashion through the labelling zone 3 and into each capture zone 4A-D.

The labelling zone 3 contains labelling complexes comprised of anti-immunoglobulin antibodies and a visible label. Alternatively, the labelling complexes may comprise antigens to each target immunoglobulin bound to a label. Each capture zone 4 A-D contains a different antigen immobilized on the surface of the matrix 1. When the labelling complexes contain antigens, the antigens in the labelling complexes and the antigens immobilized in the capture zone will typically be identical. As the serum sample flows through the labelling zone 3, immunoglobulins in the serum are bound by the labelling complex. When the serum reaches the capture zones 4 A-D, immunoglobulins specific for the immobilized antigens are retained. The presence of immunoglobulins specific for different antigens is thus simultaneously determined by observing color changes in the capture zones 4 A-D through the result windows 8A-D.

The following examples are offered by way of illustration, not by way of limitation.



EXAMPLES

The following examples demonstrate the use of devices and methods of the claimed invention in the detection of allergen-specific IgE in patient serum samples.

5 Example 1

In this example, the rapidity and sensitivity of the present invention was demonstrated by the detection of serum IgE specific for timothy grass, and mite allergens bound to the capture zone.

10 Test devices for the timothy grass and mite allergens were generally prepared by the following method. For clarity, only the devices for detection of mite antigen-specific IgE are described, however, the devices for timothy grass were similarly constructed and used.

15 Label particles were produced for use in devices of the present invention. Blue polystyrene latex particles, 0.4 $\mu$  diameter, obtained from Polymer Laboratories, Ltd., Essex Road Church, Stretton, United Kingdom, were coated with anti-IgE. One half ml of suspended particles were diluted to one ml in  
20 50 mM Tris buffer, pH 8.0, and centrifuged. The particle pellet was suspended in 1.0 ml Tris buffer by sonication on ice for 10 minutes. This process was repeated, but the particles were suspended in 0.5 ml antibody coupling solution (50 mM Tris buffer, pH 8.0, containing 10 mg/ml monoclonal  
25 mouse ant-human IgE, 1.0 mg/ml methylated bovine serum albumin (mBSA)) and mixed by rotation overnight at room temperature. Following this incubation, the particles were again centrifuged and the pellet suspended in 0.5 ml blocking solution (50 mM Tris buffer, pH 8.0, containing 10 mg/ml  
30 mBSA). The suspension was again mixed by rotation at room temperature for four hours, centrifuged, and the particle pellet suspended in Tris buffer, pH 8.0, containing 1.0 mg/ml mBSA. This suspension was immediately centrifuged, and the particle pellet twice washed in the same fashion. The final  
35 pellet was then suspended in 0.5 ml buffer. Particle concentration as a percent solids was calculated by determining the absorbance of the solution at 450 nm.

The device was then constructed. To prepare the labelling zone on the matrix, the label particles were diluted into methylated BSA at a concentration of 0.06% solids. The resulting mixture was poured onto the labelling zone membrane at 38  $\mu\text{l}/\text{cm}^2$ . The labelled membrane was kept at room temperature for five minutes and frozen with a lyophilizing flask at  $-70^\circ\text{C}$  for at least one hour. The frozen polyester membranes were lyophilized overnight on a Virtis Freezemobile. The lyophilized membranes were then cut into 10 x 7.5 mm rectangles.

The capture matrix comprised a nitrocellulose membrane. The nitrocellulose membrane, 5  $\mu$  or 8  $\mu$  pore size, was obtained from Schleicher and Schuell, Germany. Cut nitrocellulose membranes were affixed to a chart recorder. Mite allergen obtained from Hollister-Steir, Spokane, WA or Miles Allergy Products, Spokane, WA, was dispensed at 10 mg/ml in a line approximately 1.1 cm parallel to another line of rabbit anti-mouse IgG obtained from Jackson Research Laboratories, West Grove, PA which was dispensed at 0.05 mg/ml. The mite allergen line defined the capture zone of the device and the anti-mouse IgG defined the reference zone of the device. Both the mite allergen and the rabbit anti-mouse IgG were suspended in 50 mM Tris buffer, pH 8.0, before dispensing.

The nitrocellulose membrane was then placed in a tray containing 50 mM Tris maleate buffer, pH 7.0, containing 10 mg/ml mBSA for 15 minutes at room temperature. This membrane was finally blotted with ED 939 absorbent paper, obtained from Ahlstrom Filtration, Inc., Mount Holyoke, PA, allowed to dry in a convection oven at  $45^\circ\text{C}$  for 5 minutes, and stored in a desiccator at room temperature until assembly of the device. The test device was assembled in a fashion similar to those described in U.S. Patent No. 4,943,522 and U.S.S.N. 07/639,967, which have been previously incorporated by reference.

To test the assay device, patient serum known to contain immunoglobulin E (IgE) antibody specific for mite

allergen was diluted to various levels in horse serum. These dilutions were assayed by a radioallergosorbent test (RAST, Pharmacia Diagnostics) for human IgE specific to mite allergen, as well as the QUIDEL Allergen Screen assay (QAS, Quidel Corporation) in both the 90-Minute and 19-Hour formats. Both the RAST and QAS assays were performed according to the manufacturers instructions. These dilutions were then tested in lateral flow devices of the present invention to determine comparative sensitivity. The results are presented in Table 1.

The RAST assay was performed by incubating patient serum with cellulose disks, having allergen covalently attached, overnight at room temperature. The disks were then washed 3 times with buffer provided with the kit and incubated with an anti-IgE-enzyme conjugate. After another overnight incubation, the disks were washed again and developer added and incubated for 2 hours at 37°C. Finally, a stop solution was added, and the absorbance measured at 420 nm. The amount of IgE present in serum was directly proportional to the amount of color developed; standards of known IgE concentration were assayed to provide reference.

The QAS assay was performed by incubating patient serum either 30 minutes or overnight at room temperature with a dipstick to which allergen pads were affixed. Various allergen pads were prepared from cellulose by covalent attachment of allergen prior to assembly of the dipstick. The dipstick was washed under tap water for one minute and placed into an anti-IgE-enzyme conjugate solution and incubated for 30 minutes at room temperature. The dipstick was washed again and incubated for 30 minutes at room temperature in substrate solution. After blotting, the relative color intensity was determined using a reflectance densitometer (Diagnostic Solutions, Inc.).

The lateral flow test was assayed by applying 50  $\mu$ L of patient serum to the sample receiving zone of the device. Sample flowed into the labelling zone pad, releasing label particles into the nitrocellulose membrane. If allergen-

specific IgE was present in the sample, a sandwich formed between the labelling complex particle, the allergen-specific IgE in the patient sample, and the allergen immobilized in the capture zone of the device. The speed of formation and intensity of color on the capture line was directly proportional to the amount of IgE present in the sample. A positive result was scored if a color change in the capture line was detected.

Table 1

10

Serum Dilution	RAST (PRU)	RAST (Class)	Lateral Flow Signal Time (min)	90-Min QAS (QRA Class)	19-Hr QAS (QRA Class)
Neat	>17.5	4+	0.83	ND	ND
1:2	>17.5	4+	0.97	ND	ND
1:5	11.44	3+	1.17	ND	ND
1:10	4.74	3+	1.32	1+	3+
1:20	2.26	2+	2.33	1/0	2
1:50	0.65	1+	3.18	0	2
1:100	0.34	1/0	25.00	0	1/0
Horse Serum	0	0	No Signal	ND	ND

15

20

25

30

35

The above results demonstrate that the lateral flow format is able to achieve sensitivity comparable to those of the other IgE-specific overnight serum incubation assays. The lateral flow assay of the present invention is also capable of high sensitivity in a relatively short time.

40

Assays to detect IgE specific for timothy grass allergens was performed in a similar manner in devices comparable to those described above. The results of the assays are in Table 2.

Table 2  
Specific IgE  
Timothy Grass

	<u>Serum</u>	<u>Dilution</u>	<u>Rast PRU</u>	<u>Rast Class</u>	<u>Lateral Flow Signal Time (min.)</u>
5	ASB 279	Neat	>17.5	4+	0.92
	ASB 948	Neat	15	3+	1.62
10	ASB 948	1:4.35	3.5	3+	0.85
	ASB 948	1:21.7	0.7	2+	2.72
	ASB 948	1:43.5	0.35	1+	5.08
	QAR 12	Neat	0	0	0

15

Example 2

The ability of the present invention to differentiate between different antigens was demonstrated using timothy grass, and mite allergens. The allergens were bound either to the labelling complexes or the nitrocellulose capture zones. Assays were performed to detect either IgE specific for a single allergen or for the simultaneous detection of IgE specific for different allergens. In assays to simultaneously detect IgE specific for different allergens, the different allergens were bound to different capture zones. The allergens were obtained from Hollister-Steir.

The assay devices were constructed in a manner similar to those described in Example 1. Allergen was bound to both the labelling complexes and the capture zones. Timothy grass allergen was used alone on the same device, but in a different capture zone, with mite allergen. In some assays, the label for the timothy grass was a different color than the label for the mite allergen.

The results are presented in Table 3 with a comparison to tests of the serum in the Quidel QAS assays. The specificity of the assays of the present invention are clearly demonstrated.

Table 3

	Serum Specificity Identification	Timothy Specificity		Mite Specificity	
		QAS	Lateral Flow	QAS	Lateral Flow
5	12	-	+/-	-	+/-
10	271	-	-	++	+/-
	274	+	+	++++	+
	950	+++	+	++++	+
15	1098	++++	+	-	-
	1099	+++	+	++	+
20					

In other tests, allergens were bound to different colored label particles and capture lines, and were tested in the lateral flow assay format of the present invention.

25 Timothy grass, mite, ragweed, cat, and wheat antigens were coupled to different colored label particles (Bangs Laboratories, Inc.), and timothy, mite, ragweed, cat, wheat (Hollister-Steir) and rabbit anti-mouse IgG (Jackson Research Laboratories) were bound to separate capture lines on the  
30 nitrocellulose matrices. These materials were assembled into lateral flow devices as described in Example 1. Sera of different specificities were assayed in the device.

Results are presented in Table 4; parenthetical colors indicate label particle color. There was no color  
35 overlap on different capture lines, indicating that it is possible to assay multiple analytes in a single assay format.

Table 4

	Serum Control Identification (Red)	Timothy (Blue)	Mite (Pink)	Ragweed (Green)	Cat (Purple)	Wheat (Violet)
5	274	+	1/0	+	-	+
	+					
10	891	+	+	+	-	+
	+					
15	950	+	+	+	-	+
	+					
	1098	+	-	-	-	+
	+					
20						

Example 3

In this example, allergen was bound to the label particle and anti-human IgE antibody was bound to the capture line. Timothy grass allergen was coupled to label particle and monoclonal mouse anti-human IgE (Quidel) or polyclonal goat anti-human IgE (KPL Laboratories, Inc.) was bound to the capture line. Sera with known timothy grass specificity were then assayed in the assembled devices.

Individual raw or purified allergen extracts were coated overnight at room temperature at 0.5-5.0 mg/ml to colored latex (Bang's Lab's) followed by blocking with 10 mg/ml methylated BSA. The mixture was chromatographed over a Sepharose CL-4B-200 column (Sigma) to remove unbound allergen. The eluent was collected and suspended in 10mg/ml methylated BSA at 0.06-0.08% solids and was then poured onto the label zone membrane and lyophilized.

The assay device was prepared as described in example 1 except that anti-human IgE antibodies were bound to the capture zone of the device. The anti-IgE antibodies were applied to the matrix by a chart recorder in a suspension of 50 mM Tris buffer, pH 8.0. The anti-IgE antibodies were dispensed at 5 mg/ml.

The results are presented in Table 5. The device and the method provided consistent specificity for the tested antigens.

Table 5

	Serum Identification	Timothy QAS	Mouse Ab Capture	Goat Ab Capture
5	12	-	-	-
	271	-	-	-
10	279	+++	+	+
	1098	++++	+	+

15 All publications and patent applications mentioned  
in this specification are indicative of the level of skill of  
those skilled in the art to which this invention pertains.  
All publications, patents and patent applications are herein  
incorporated by reference to the same extent as if each  
20 individual publication, patent or patent application was  
specifically and individually indicated to be incorporated  
herein by reference.

Although the foregoing invention has been described  
in some detail by way of illustration and example, for  
25 purposes of clarity and understanding, it will be obvious that  
changes and modifications may be practiced within the scope of  
the appended claims.



WHAT IS CLAIMED IS:

1. An assay for determining, in a biological fluid sample, the presence, absence, or amount of immunoglobulins specific for an antigen, said assay comprising:

a. applying the sample to a sample receiving zone on a matrix having a flow path to a capture zone located downstream from the sample receiving zone,

wherein the sample also flows through a means for labelling the immunoglobulins, which labelling means contains a labelling complex comprising a visible label bound to a first immunoglobulin-binding substance,

a second immunoglobulin-binding substance is immobilized in the capture zone, and

at least one of the first immunoglobulin-binding substances and the second immunoglobulin-binding substances is the antigen; and

b. observing the accumulation of visible label within the capture zone as a result of immunoglobulin present in the sample specific for the antigen specifically binding to the labelling complex in the labelling means and the resulting immunoglobulin-labelling complex flowing into and being captured within the capture zone.

2. An assay as in claim 1, wherein the biological fluid is whole blood, serum or plasma.

3. An assay as in claim 1, wherein the labelling means is located in an axial flow path between the sample receiving zone and the capture zone.

4. An assay as in claim 1, wherein the labelling means is a sample receiving pad in contact and on the surface of the sample receiving zone.

5. An assay as in claim 1, wherein the antigen is an allergen and the immunoglobulin is IgE.

5 6. An assay as in claim 5, wherein one of the immunoglobulin-binding substances is the allergen and the other is anti-IgE.

10 7. The assay as in claim 6, wherein the first immunoglobulin binding substance is the allergen.

8. An assay as in claim 6, wherein both of the immunoglobulin-binding substances are the allergen.

15 9. An assay as in claim 1, wherein the antigen is from a pathogen.

20 10. An assay as in claim 9, wherein the pathogen is *Helicobacter pylori*, *Borrelia burgdorferi*, *Toxoplasma gondii*, Cytomegalovirus, Herpes Simplex virus, *Treponema pallidum*, Rubella virus, or *Chlamydia trachomatis*.

25 11. An assay as in claim 1, wherein the antigen is from a food.

12. An assay as in claim 11, wherein the food is derived from wheat gluten.

30 13. An assay as in claim 7 to assess the efficacy of a treatment, further comprising repeating steps a and b following the treatment and comparing the accumulation of visible label in the capture zones and thereby determining treatment efficacy.

35 14. An assay as in claim 1, wherein the matrix is a non-bibulous flow membrane.

15. An assay as in claim 1, wherein the accumulation of visible label is visually compared to a reference standard.

5           16. An assay as in claim 15, wherein the accumulation of visible label is compared to the reference standard by a reflectance analyzer or video image analyzer.

10           17. An assay for determining IgE levels in a patient serum sample, said assay comprising:

          applying the serum sample to a sample receiving zone on a matrix having an axial flow path defining a labelling zone located downstream from the receiving zone and a capture zone located downstream from the labelling zone, wherein a labelling complex comprising a visible label bound to a first IgE-binding substance is present in the labelling zone and a second IgE-binding substance is immobilized in the capture zone;

20           observing the accumulation of label within the capture zone as a result of IgE present in the patient sample specifically binding to the labelling complex in the labelling zone and the resulting IgE-labelling complex flowing into and being captured within the capture zone; and

25           comparing the accumulation of label to reference standards.

30           18. An assay as in claim 17, wherein both of the IgE-binding substances are anti-IgE, whereby the assay device measures the total IgE present in the patient serum sample.

19. An assay for simultaneously determining, in a biological fluid sample, the presence, absence, or amount of each of a plurality of immunoglobulins specific for different antigens, said assay comprising:

5 a. applying the sample to a sample receiving zone on a matrix having a flow path to a plurality of capture zones located downstream from the sample receiving zone,

10 wherein the sample flows through at least one means for labelling the immunoglobulins, each labelling means having a labelling complex comprising a visible label bound to an immunoglobulin-binding substance, and

each different antigen is immobilized in a different capture zone; and

15 b. observing the accumulation of visible label within each capture zone as a result of immunoglobulin present in the sample specific for an antigen specifically binding to the labelling complex in the labelling means and the resulting immunoglobulin-labelling complex flowing into and being captured within  
20 each capture zone.

20. An assay as in claim 19, wherein the antigens are blood group antigens.

25

30

35

21. A device for determining, in a biological fluid sample, levels of antigen-specific immunoglobulins reactive with an antigen, said device comprising:

5 a means for labelling the immunoglobulins having a labelling complex comprising a visible label bound to a first immunoglobulin-binding substance;

10 a matrix defining an axial flow path, said matrix having a sample receiving zone, a capture zone located downstream from the sample receiving zone, and an absorbent zone located downstream from the capture zone; and

a second immunoglobulin-binding substance immobilized in the capture zone;

15 whereby application of the sample to the sample receiving zone results in specific binding of immunoglobulin present in the serum to labelling complex in the labelling means and accumulation of antigen-specific immunoglobulin-labelling complex in the capture zone based on the amount of antigen-specific  
20 immunoglobulin initially present in the serum sample.

22. A device as in claim 21, wherein the labelling means is a sample receiving pad in contact and on the surface of the sample receiving zone.

25 23. A device as in claim 21, wherein the labelling means is a labelling zone located in the axial flow path between the sample receiving zone and the capture zone.

24. A device as in claim 21, wherein the antigen is an allergen and the immunoglobulins are IgE.

35 25. A device as in claim 24, wherein the first immunoglobulin binding substance is the allergen.

26. A device as in claim 24, wherein one of the immunoglobulin-binding substances is the allergen and the other is anti-IgE.

5 27. A device as in claim 24, wherein both of the immunoglobulin-binding substances are the allergen.

28. A device as in claim 21, wherein the matrix is a non-bibulous flow membrane.

10

29. A device for determining IgE levels in a patient, said device comprising:

15 a matrix defining an axial flow path, said matrix having a sample receiving zone, a labelling zone located downstream from the sample receiving zone, a capture zone located downstream from the labelling zone, and an absorbent zone located downstream from the capture zone;

20 a labelling complex comprising a visible label bound to a first IgE-binding substance present in the labelling zone; and

a second IgE-binding substance immobilized in the capture zone;

25 whereby application of a patient serum sample to the sample receiving zone results in specific binding of IgE present in the serum to labelling complex in the labelling zone and accumulation of IgE-labelling complex in the capture zone based on the amount of IgE initially present in the serum sample.

30

30. A device as in claim 29, wherein both of the IgE-binding substances are anti-IgE, whereby the assay device measures the total IgE present in the serum sample.

35

31. A device for determining, in a patient sample, levels of a plurality of antigen-specific immunoglobulins reactive with a plurality of different antigens, said device comprising:

5                   at least one means for labelling the immunoglobulins, each labelling means having a labelling complex comprising a visible label bound to a first immunoglobulin-binding substance,  
                  a matrix defining a flow path, said matrix  
10                   having a sample receiving zone,  
                  a plurality of capture zones located downstream from the sample receiving zone, and  
                  an absorbent zone located downstream from the capture zones;  
15                   a plurality of second immunoglobulin-binding substances, each immobilized in a different capture zone;  
                  whereby application of the patient serum sample to the sample receiving zone results in specific binding of immunoglobulin present in the serum to labelling  
20                   complexes in the labelling means and accumulation of antigen-specific immunoglobulin-labelling complex in the different capture zones based on the amount of different antigen-specific immunoglobulins initially present in the serum sample.

25                   32. A device as in claim 31, wherein the second immunoglobulin-binding substances are a *Toxoplasma gondii* antigen, a Rubella virus antigen, a Cytomegalovirus antigen, a Herpes Simplex virus antigen,  
30                   a *Chlamydia trachomatis* antigen, a *Treponema pallidum* antigen and a *Helicobacter pylori* antigen and each second immunoglobulin-binding substance is immobilized in a different capture zone.

35                   33. A device as in claim 31, wherein the first immunoglobulin-binding substance is anti-IgG or anti-IgM.

34. A device as in claim 31, wherein the second immunoglobulin binding substances are blood group antigens.



1/2

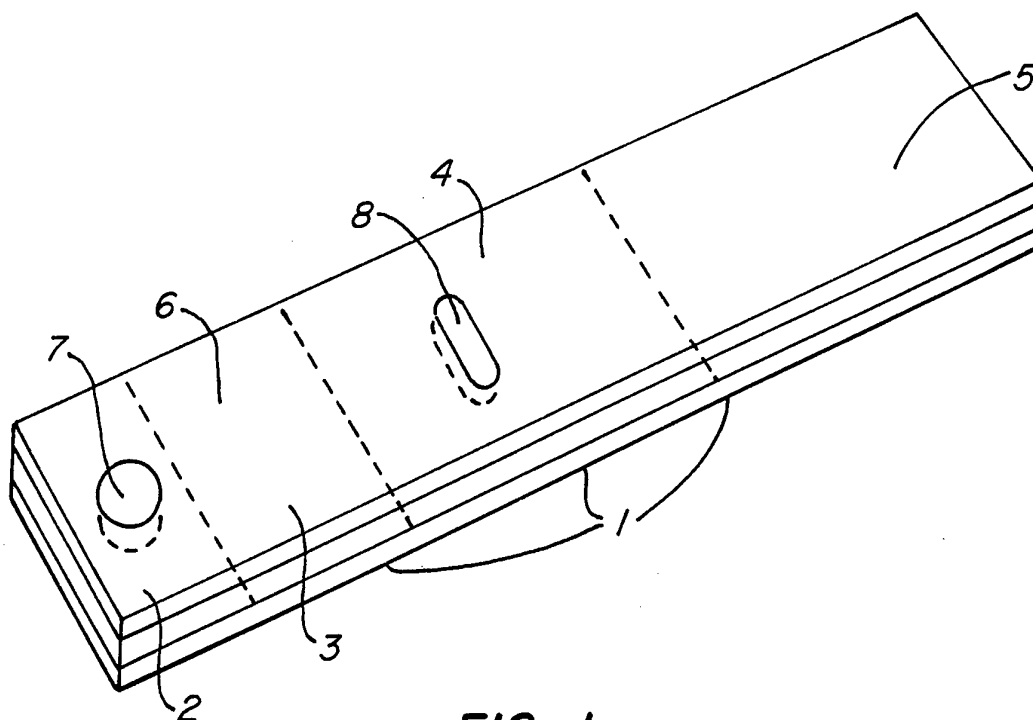

FIG. 1.

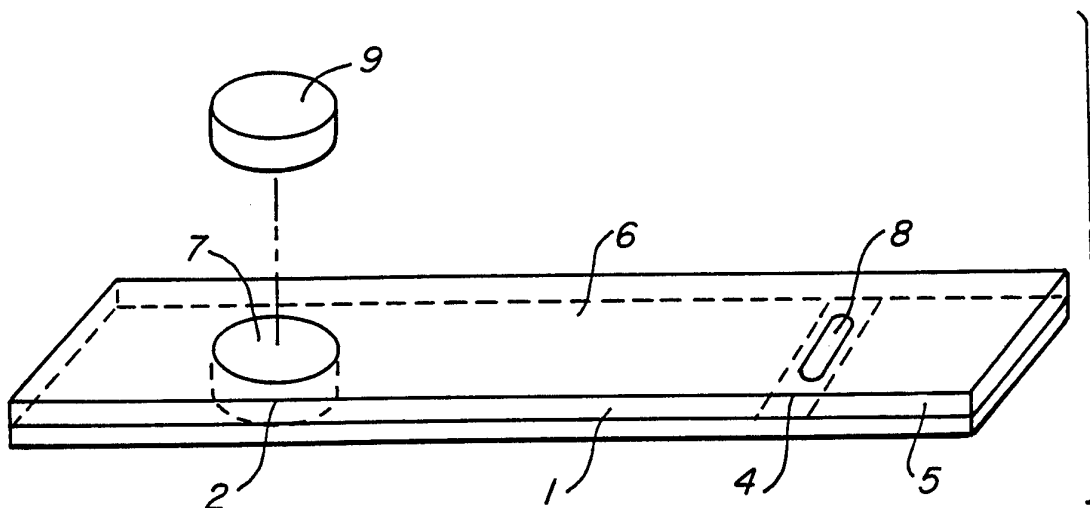

FIG. 2.

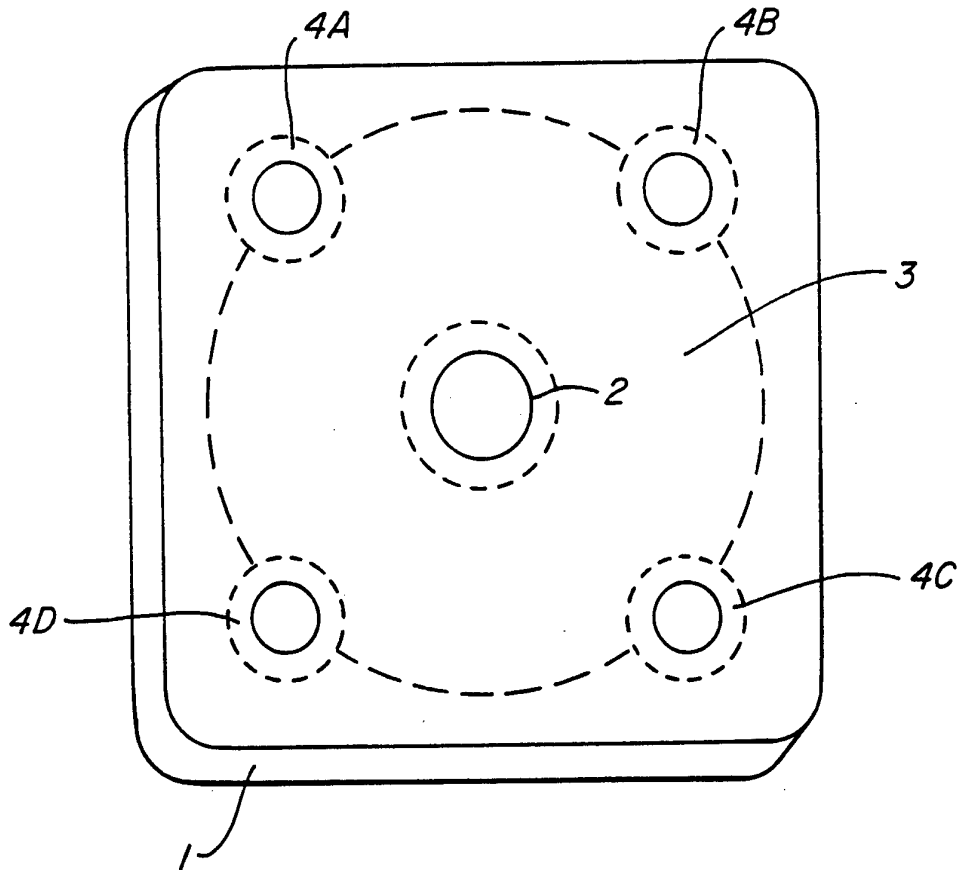

FIG. 3.

INTERNATIONAL SEARCH REPORT

International application No.  
PCT/US94/05870

**A. CLASSIFICATION OF SUBJECT MATTER**  
 IPC(5) :Please See Extra Sheet.  
 US CL :Please See Extra Sheet.  
 According to International Patent Classification (IPC) or to both national classification and IPC

**B. FIELDS SEARCHED**  
 Minimum documentation searched (classification system followed by classification symbols)  
 U.S. : Please See Extra Sheet.

Documentation searched other than minimum documentation to the extent that such documents are included in the fields searched

Electronic data base consulted during the international search (name of data base and, where practicable, search terms used)

**C. DOCUMENTS CONSIDERED TO BE RELEVANT**

Category*	Citation of document, with indication, where appropriate, of the relevant passages	Relevant to claim No.
X ----	GB, A, 2,204,398 (MAY ET AL) 09 November 1988, see Figs. 1, 2 and 9; page 2, line 1; page 3, line 21 - page 4, line 2; page 4, lines 15-16 and 24-26; page 5, lines 26-34; page 6, lines 22 and 28-32; page 10, lines 10-13; page 11, lines 10-17 and 22-27; page 12, line 31 - page 13, line 1; page 17, lines 6-7.	1, 3-4, 14, 19, 21-23, 28, 31
Y		----- 2, 5-13, 15-18, 20, 24-27, 29-30, 32-34
Y	US, A, 4,943,522 (EISINGER ET AL) 24 July 1990, see Fig. 2; col. 4, lines 44-52; col. 5, lines 12-18, 28-36 and 61; col. 8, lines 8-13, 17-22 and 31-60; col. 10, lines 26-37; col. 11, lines 14-23; col. 12, lines 4-6; col. 13, line 55 - col. 14, line 7; col. 18, lines 11-18, 33, 40-41 and 53-55; Example 3.	1-34

Further documents are listed in the continuation of Box C.       See patent family annex.

* Special categories of cited documents:	"T" later document published after the international filing date or priority date and not in conflict with the application but cited to understand the principle or theory underlying the invention
"A" document defining the general state of the art which is not considered to be of particular relevance	"X" document of particular relevance; the claimed invention cannot be considered novel or cannot be considered to involve an inventive step when the document is taken alone
"E" earlier document published on or after the international filing date	"Y" document of particular relevance; the claimed invention cannot be considered to involve an inventive step when the document is combined with one or more other such documents, such combination being obvious to a person skilled in the art
"L" document which may throw doubts on priority claim(s) or which is cited to establish the publication date of another citation or other special reason (as specified)	"&" document member of the same patent family
"O" document referring to an oral disclosure, use, exhibition or other means	
"P" document published prior to the international filing date but later than the priority date claimed	

Date of the actual completion of the international search 07 SEPTEMBER 1994	Date of mailing of the international search report <b>SEP 19 1994</b>
--	--

Name and mailing address of the ISA/US Commissioner of Patents and Trademarks Box PCT Washington, D.C. 20231 Facsimile No. (703) 305-3230	Authorized officer CAROL A. SPIEGEL <i>C. Spiegel</i> Telephone No. (703)308-0196
---	---

## INTERNATIONAL SEARCH REPORT

International application No.  
PCT/US94/05870

C (Continuation). DOCUMENTS CONSIDERED TO BE RELEVANT		
Category*	Citation of document, with indication, where appropriate, of the relevant passages	Relevant to claim No.
Y	WO, A, 92/19970 (CALENOFF) 12 November 1992, see page 7, line 11- page 13, line 34.	1-34
Y	T. NGO et al, "ENZYME-MEDIATED IMMUNOASSAY", published 1985 by Plenum Press (New York), pages 223-239, see page 224.	1-34
Y	US, A, 4,459,360 (MARINKOVICH) 10 July 1984, see col. 4, line 44 - col. 5, line 50.	1-34
Y	US, A, 5,091,318 (ANAWIS ET AL) 25 September 1992, see col. 2, line 10 - col. 3, line 35.	1-34
Y	US, A, 4,256,833 (ALI ET AL) 17 March 1981, see col. 1, lines 28-42, col. 2, lines 54-56.	13, 33
Y	US, A, 4,273,756 (LING ET AL) 16 June 1981, see col. 1, lines 33-68.	13, 33
A	US, A, 5,079,142 (COLEMAN ET AL) 07 January 1992, see entire document.	1-34
A	US, A, 4,920,046 (MC FARLAND ET AL) 24 April 1990, see entire document.	1-34
A	US, A, 4,703,017 (CAMPBELL ET AL) 27 October 1987, see entire document.	1-34
A	EP, A, 171,150 (HERZBERG ET AL) 12 February 1980, see entire document.	1-34
A	SU, A, 1,165,365 (GORKI PEDAGOGUE INS) 07 July 1985, see entire document.	1-34
A	US, A, 4,861,711 (FRIESEN ET AL) 29 August 1989, see entire document.	1-34

**INTERNATIONAL SEARCH REPORT**

International application No.  
PCT/US94/05870

**A. CLASSIFICATION OF SUBJECT MATTER:**

IPC (5):

G01N 21/00, 31/00, 33/53, 33/537, 33/538, 33/541, 33/543, 33/545, 33/546, 33/553, 33/554, 33/563 ; C12Q 1/00, 1/70

**A. CLASSIFICATION OF SUBJECT MATTER:**

US CL :

422/55, 56, 57, 60; 424/11; 435/5, 7.2, 7.31, 7.32, 7.33, 7.34, 7.35; 436/169, 513, 518, 523, 525, 529, 530, 531, 533, 534, 538, 540, 541

**B. FIELDS SEARCHED**

Minimum documentation searched

Classification System: U.S.

422/55, 56, 57, 60; 424/11; 435/5, 7.2, 7.31, 7.32, 7.33, 7.34, 7.35, 805, 810, 967, 970, 971, 973, 974; 436/169, 513, 518, 523, 525, 529, 530, 531, 533, 534, 538, 540, 541, 809, 810, 811, 820