

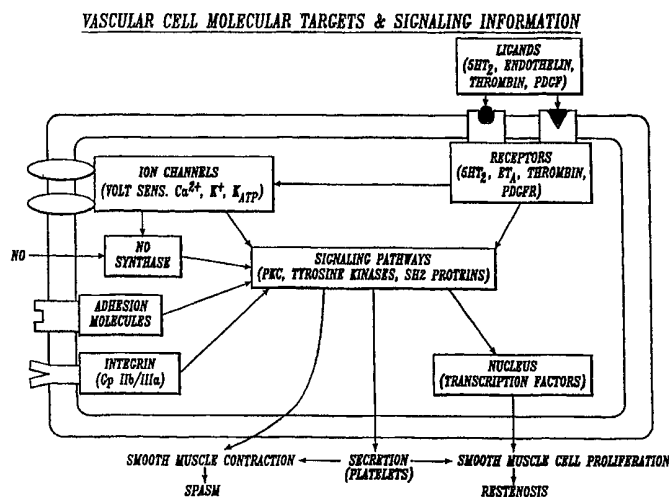

INTERNATIONAL APPLICATION PUBLISHED UNDER THE PATENT COOPERATION TREATY (PCT)

<p>(51) International Patent Classification ⁷ : A61K 31/00</p>	<p>A2</p>	<p>(11) International Publication Number: WO 00/23061</p> <p>(43) International Publication Date: 27 April 2000 (27.04.00)</p>
<p>(21) International Application Number: PCT/US99/24557</p> <p>(22) International Filing Date: 20 October 1999 (20.10.99)</p> <p>(30) Priority Data: 60/105,166 21 October 1998 (21.10.98) US</p> <p>(71) Applicant (for all designated States except US): OMEROS MEDICAL SYSTEMS, INC. [US/US]; Suite 2050, 1420 Fifth Avenue, Seattle, WA 98101 (US).</p> <p>(72) Inventors; and (75) Inventors/Applicants (for US only): DEMOPULOS, Gregory, A. [US/US]; 6530 - 83rd Place S.E., Mercer Island, WA 98040 (US). PALMER, Pamela, P. [US/US]; 48 Hillpoint Avenue, San Francisco, CA 94117 (US). HERZ, Jeffrey, M. [US/US]; 14427 12th Drive S.E., Mill Creek, WA 98012 (US).</p> <p>(74) Agent: SHELTON, Dennis, K.; Christensen O'Connor Johnson & Kindness PLLC, Suite 2800, 1420 Fifth Avenue, Seattle, WA 98101 (US).</p>		<p>(81) Designated States: AE, AL, AM, AT, AU, AZ, BA, BB, BG, BR, BY, CA, CH, CN, CR, CU, CZ, DE, DK, DM, EE, ES, FI, GB, GD, GE, GH, GM, HR, HU, ID, IL, IN, IS, JP, KE, KG, KP, KR, KZ, LC, LK, LR, LS, LT, LU, LV, MA, MD, MG, MK, MN, MW, MX, NO, NZ, PL, PT, RO, RU, SD, SE, SG, SI, SK, SL, TJ, TM, TR, TT, TZ, UA, UG, US, UZ, VN, YU, ZA, ZW, ARIPO patent (GH, GM, KE, LS, MW, SD, SL, SZ, TZ, UG, ZW), Eurasian patent (AM, AZ, BY, KG, KZ, MD, RU, TJ, TM), European patent (AT, BE, CH, CY, DE, DK, ES, FI, FR, GB, GR, IE, IT, LU, MC, NL, PT, SE), OAPI patent (BF, BJ, CF, CG, CI, CM, GA, GN, GW, ML, MR, NE, SN, TD, TG).</p> <p>Published Without international search report and to be republished upon receipt of that report.</p>

(54) Title: IRRIGATION SOLUTION AND METHOD FOR INHIBITION OF PAIN AND INFLAMMATION



(57) Abstract

A method and solution for perioperatively inhibiting a variety of pain and inflammation processes at wounds from general surgical procedures including oral/dental procedures. The solution preferably includes at least one COX-2 inhibitor and, optionally, additional multiple pain and inflammation inhibitory agents at dilute concentration in a physiologic carrier, such as saline or lactated Ringer's solution. The solution is applied by continuous irrigation of a wound during a surgical procedure for preemptive inhibition of pain and while avoiding undesirable side effects associated with oral, intramuscular, subcutaneous or intravenous application of larger doses of the agents. One preferred solution to inhibit pain and inflammation includes a COX-2 inhibitor, a serotonin₂ antagonist, a serotonin₃ antagonist, a histamine antagonist, a serotonin agonist, a cyclooxygenase inhibitor, a neurokinin₁ antagonist, a neurokinin₂ antagonist, a purinoceptor antagonist, an ATP-sensitive potassium channel opener, a calcium channel antagonist, a bradykinin₁ antagonist, a bradykinin₂ antagonist and a μ -opioid agonist.

FOR THE PURPOSES OF INFORMATION ONLY

Codes used to identify States party to the PCT on the front pages of pamphlets publishing international applications under the PCT.

AL	Albania	ES	Spain	LS	Lesotho	SI	Slovenia
AM	Armenia	FI	Finland	LT	Lithuania	SK	Slovakia
AT	Austria	FR	France	LU	Luxembourg	SN	Senegal
AU	Australia	GA	Gabon	LV	Latvia	SZ	Swaziland
AZ	Azerbaijan	GB	United Kingdom	MC	Monaco	TD	Chad
BA	Bosnia and Herzegovina	GE	Georgia	MD	Republic of Moldova	TG	Togo
BB	Barbados	GH	Ghana	MG	Madagascar	TJ	Tajikistan
BE	Belgium	GN	Guinea	MK	The former Yugoslav Republic of Macedonia	TM	Turkmenistan
BF	Burkina Faso	GR	Greece	ML	Mali	TR	Turkey
BG	Bulgaria	HU	Hungary	MN	Mongolia	TT	Trinidad and Tobago
BJ	Benin	IE	Ireland	MR	Mauritania	UA	Ukraine
BR	Brazil	IL	Israel	MW	Malawi	UG	Uganda
BY	Belarus	IS	Iceland	MX	Mexico	US	United States of America
CA	Canada	IT	Italy	NE	Niger	UZ	Uzbekistan
CF	Central African Republic	JP	Japan	NL	Netherlands	VN	Viet Nam
CG	Congo	KE	Kenya	NO	Norway	YU	Yugoslavia
CH	Switzerland	KG	Kyrgyzstan	NZ	New Zealand	ZW	Zimbabwe
CI	Côte d'Ivoire	KP	Democratic People's Republic of Korea	PL	Poland		
CM	Cameroon	KR	Republic of Korea	PT	Portugal		
CN	China	KZ	Kazakstan	RO	Romania		
CU	Cuba	LC	Saint Lucia	RU	Russian Federation		
CZ	Czech Republic	LI	Liechtenstein	SD	Sudan		
DE	Germany	LK	Sri Lanka	SE	Sweden		
DK	Denmark	LR	Liberia	SG	Singapore		
EE	Estonia						

IRRIGATION SOLUTION AND METHOD FOR INHIBITION OF PAIN AND INFLAMMATION

I. Field of the Invention

5 The present invention relates to surgical irrigation solutions and methods, and particularly for anti-inflammatory, anti-pain, anti-spasm and anti-restenosis surgical irrigation solutions.

II. Background of the Invention

10 Arthroscopy is a surgical procedure in which a camera, attached to a remote light source and video monitor, is inserted into an anatomic joint (e.g., knee, shoulder, etc.) through a small portal incision in the overlying skin and joint capsule. Through similar portal incisions, surgical instruments may be placed in the joint, their use guided by arthroscopic visualization. As arthroscopists' skills have improved, an increasing number of operative procedures, once performed by "open" surgical technique, now can be accomplished arthroscopically. Such procedures
15 include, for example, partial meniscectomies and ligament reconstructions in the knee, shoulder acromioplasties and rotator cuff debridements and elbow synovectomies. As a result of widening surgical indications and the development of small diameter arthroscopes, wrist and ankle arthroscopies also have become routine.

20 Throughout each arthroscopy, physiologic irrigation fluid (e.g., normal saline or lactated Ringer's) is flushed continuously through the joint, distending the joint capsule and removing operative debris, thereby providing clearer intra-articular visualization. U.S. Patent 4,504,493 to Marshall discloses an isomolar solution of

glycerol in water for a non-conductive and optically clear irrigation solution for arthroscopy.

Irrigation is also used in other procedures, such as cardiovascular and general vascular diagnostic and therapeutic procedures, urologic procedures and the treatment of burns and any operative wounds. In each case, a physiologic fluid is used to irrigate a wound or body cavity or passage. Conventional physiologic irrigation fluids do not provide analgesic, anti-inflammatory, anti-spasm and anti-restenotic effects.

Alleviating pain and suffering in postoperative patients is an area of special focus in clinical medicine, especially with the growing number of out-patient operations performed each year. The most widely used agents, cyclooxygenase inhibitors (e.g., ibuprofen) and opioids (e.g., morphine, fentanyl), have significant side effects including gastrointestinal irritation/bleeding and respiratory depression. The high incidence of nausea and vomiting related to opioids is especially problematic in the postoperative period. Therapeutic agents aimed at treating postoperative pain while avoiding detrimental side effects are not easily developed because the molecular targets for these agents are distributed widely throughout the body and mediate diverse physiological actions. Despite the significant clinical need to inhibit pain and inflammation, as well as vasospasm, smooth muscle spasm and restenosis, methods for the delivery of inhibitors of pain, inflammation, spasm and restenosis at effective dosages while minimizing adverse systemic side effects have not been developed. As an example, conventional (i.e., intravenous, oral, subcutaneous or intramuscular) methods of administration of opiates in therapeutic doses frequently is associated with significant adverse side effects, including severe respiratory depression, changes in mood, mental clouding, profound nausea and vomiting.

Prior studies have demonstrated the ability of endogenous agents, such as serotonin (5-hydroxytryptamine, sometimes referred to herein as "5-HT"), bradykinin and histamine, to produce pain and inflammation. Sicuteri, F., et. al., *Serotonin-Bradykinin Potentiation in the Pain Receptors in Man*, Life Sci. 4, pp. 309-316 (1965); Rosenthal, S.R., *Histamine as the Chemical Mediator for Cutaneous Pain*, J. Invest. Dermat. 69, pp. 98-105 (1977); Richardson, B.P., et. al., *Identification of Serotonin M-Receptor Subtypes and their Specific Blockade by a New Class of Drugs*, Nature 316, pp. 126-131 (1985); Whalley, E.T., et. al., *The Effect of Kinin Agonists and Antagonists*, Naunyn-Schmiedeb Arch. Pharmacol. 36, pp. 652-57

(1987); Lang, E., et. al., *Chemo-Sensitivity of Fine Afferents from Rat Skin In Vitro*, J. Neurophysiol. 63, pp. 887-901 (1990).

For example, 5-HT applied to a human blister base (denuded skin) has been demonstrated to cause pain that can be inhibited by 5-HT₃ receptor antagonists. Richardson et al., (1985). Similarly, peripherally-applied bradykinin produces pain which can be blocked by bradykinin receptor antagonists. Sicuteri et al., 1965; Whalley et al., 1987; Dray, A., et. al., *Bradykinin and Inflammatory Pain*, Trends Neurosci. 16, pp. 99-104 (1993). Peripherally-applied histamine produces vasodilation, itching and pain which can be inhibited by histamine receptor antagonists. Rosenthal, 1977; Douglas, W.W., "Histamine and 5-Hydroxytryptamine (Serotonin) and their Antagonists", in Goodman, L.S., et.al., ed., *The Pharmacological Basis of Therapeutics*, MacMillan Publishing Company, New York, pp. 605-638 (1985); Rumore, M.M., et. al., *Analgesic Effects of Antihistaminics*, Life Sci 36, pp. 403-416 (1985). Combinations of these three agonists (5-HT, bradykinin and histamine) applied together have been demonstrated to display a synergistic pain-causing effect, producing a long-lasting and intense pain signal. Sicuteri et al., 1965; Richardson et al., 1985; Kessler, W., et. al., *Excitation of Cutaneous Afferent Nerve Endings In Vitro by a Combination of Inflammatory Mediators and Conditioning Effect of Substance P*, Exp. Brain Res. 91, pp. 467-476 (1992).

In the body, 5-HT is located in platelets and in central neurons, histamine is found in mast cells, and bradykinin is produced from a larger precursor molecule during tissue trauma, pH changes and temperature changes. Because 5-HT can be released in large amounts from platelets at sites of tissue injury, producing plasma levels 20-fold greater than resting levels (Ashton, J.H., et. al., *Serotonin as a Mediator of Cyclic Flow Variations in Stenosed Canine Coronary Arteries*, Circulation 73, pp. 572-578 (1986)), it is possible that endogenous 5-HT plays a role in producing postoperative pain, hyperalgesia and inflammation. In fact, activated platelets have been shown to excite peripheral nociceptors *in vitro*. Ringkamp, M., et. al., *Activated Human Platelets in Plasma Excite Nociceptors in Rat Skin, In Vitro*, Neurosci. Lett. 170, pp. 103-106 (1994). Similarly, histamine and bradykinin also are released into tissues during trauma. Kimura, E., et. al., *Changes in Bradykinin Level in Coronary Sinus Blood After the Experimental Occlusion of a Coronary Artery*, Am Heart J. 85, pp. 635-647 (1973); Douglas, 1985; Dray et al. (1993).

In addition, prostaglandins also are known to cause pain and inflammation. Cyclooxygenase inhibitors, e.g., ibuprofen, are commonly used in non-surgical and

post-operative settings to block the production of prostaglandins, thereby reducing prostaglandin-mediated pain and inflammation. Flower, R.J., et. al., *Analgesic-Antipyretics and Anti-Inflammatory Agents; Drugs Employed in the Treatment of Gout*, in Goodman, L.S., et. al., ed., *The Pharmacological Basis of Therapeutics*, 5 MacMillan Publishing Company, New York, pp. 674-715 (1985). Cyclooxygenase inhibitors are associated with some adverse systemic side effects when applied conventionally. For example, indomethacin or ketorolac have well recognized gastrointestinal and renal adverse side effects.

As discussed, 5-HT, histamine, bradykinin and prostaglandins cause pain and 10 inflammation. The various receptors through which these agents mediate their effects on peripheral tissues have been known and/or debated for the past two decades. Most studies have been performed in rats or other animal models. However, there are differences in pharmacology and receptor sequences between human and animal species. There have been no studies conclusively demonstrating 15 the importance of 5-HT, bradykinin or histamine in producing postoperative pain in humans.

Furthermore, antagonists of these mediators currently are not used for postoperative pain treatment. A class of drugs, termed 5-HT and norepinephrine uptake antagonists, which includes amitriptyline, has been used orally with moderate 20 success for chronic pain conditions. However, the mechanisms of chronic versus acute pain states are thought to be considerably different. In fact, two studies in the acute pain setting using amitriptyline perioperatively have shown no pain-relieving effect of amitriptyline. Levine, J.D., et. al., *Desipramine Enhances Opiate Postoperative Analgesia*, *Pain* 27, pp. 45-49 (1986); Kerrick, J.M., et. al., *Low-Dose 25 Amitriptyline as an Adjunct to Opioids for Postoperative Orthopedic Pain: a Placebo-Controlled Trial Period*, *Pain* 52, pp. 325-30 (1993). In both studies the drug was given orally. The second study noted that oral amitriptyline actually produced a lower overall sense of well-being in postoperative patients, which may be due to the drug's affinity for multiple amine receptors in the brain.

30 Amitriptyline, in addition to blocking the uptake of 5-HT and norepinephrine, is a potent 5-HT receptor antagonist. Therefore, the lack of efficacy in reducing postoperative pain in the previously-mentioned studies would appear to conflict with the proposal of a role for endogenous 5-HT in acute pain. There are a number of reasons for the lack of acute pain relief found with amitriptyline in these two studies. 35 (1) The first study (Levine et al., 1986) used amitriptyline preoperatively for one week up until the night prior to surgery whereas the second study (Kerrick et al.,

1993) only used amitriptyline postoperatively. Therefore, no amitriptyline was present in the operative site tissues during the actual tissue injury phase, the time at which 5-HT is purported to be released. (2) Amitriptyline is known to be extensively metabolized by the liver. With oral administration, the concentration of amitriptyline in the operative site tissues may not have been sufficiently high for a long enough time period to inhibit the activity of postoperatively released 5-HT in the second study. (3) Since multiple inflammatory mediators exist, and studies have demonstrated synergism between the inflammatory mediators, blocking only one agent (5-HT) may not sufficiently inhibit the inflammatory response to tissue injury.

There have been a few studies demonstrating the ability of extremely high concentrations (1% - 3% solutions -- i.e., 10 - 30 mg per milliliter) of histamine₁ (H₁) receptor antagonists to act as local anesthetics for surgical procedures. This anesthetic effect is not believed to be mediated via H₁ receptors but, rather, due to a non-specific interaction with neuronal membrane sodium channels (similar to the action of lidocaine). Given the side effects (e.g., sedation) associated with these high "anesthetic" concentrations of histamine receptor antagonists, local administration of histamine receptor antagonists currently is not used in the perioperative setting.

III. Summary of the Invention

The present invention provides a solution constituting at least COX-2 inhibitor and preferably a mixture of multiple agents in low concentrations directed at inhibiting locally the mediators of pain, inflammation, spasm and restenosis in a physiologic electrolyte carrier fluid. The invention also provides a method for perioperative delivery of the irrigation solution containing these agents directly to a surgical site, where it works locally at the receptor and enzyme levels to preemptively limit pain, inflammation, spasm and restenosis at the site. Due to the local perioperative delivery method of the present invention, a desired therapeutic effect can be achieved with lower doses of agents than are necessary when employing other methods of delivery (i.e., intravenous, intramuscular, subcutaneous and oral). The anti-pain/anti-inflammation agents in the solution include agents selected from the following classes of receptor antagonists and agonists and enzyme activators and inhibitors, each class acting through a differing molecular mechanism of action for pain and inflammation inhibition: (1) serotonin receptor antagonists; (2) serotonin receptor agonists; (3) histamine receptor antagonists; (4) bradykinin receptor antagonists; (5) kallikrein inhibitors; (6) tachykinin receptor antagonists, including neurokinin₁ and neurokinin₂ receptor subtype antagonists; (7) calcitonin gene-related

peptide (CGRP) receptor antagonists; (8) interleukin receptor antagonists; (9) inhibitors of enzymes active in the synthetic pathway for arachidonic acid metabolites, including (a) phospholipase inhibitors, including PLA₂ isoform inhibitors and PLC_γ isoform inhibitors, (b) cyclooxygenase inhibitors, and (c) lipoxygenase inhibitors; (10) prostanoid receptor antagonists including eicosanoid EP-1 and EP-4 receptor subtype antagonists and thromboxane receptor subtype antagonists; (11) leukotriene receptor antagonists including leukotriene B₄ receptor subtype antagonists and leukotriene D₄ receptor subtype antagonists; (12) opioid receptor agonists, including μ-opioid, δ-opioid, and κ-opioid receptor subtype agonists; (13) purinoceptor agonists and antagonists including P_{2X} receptor antagonists and P_{2Y} receptor agonists; and (14) adenosine triphosphate (ATP)-sensitive potassium channel openers. Each of the above agents functions either as an anti-inflammatory agent and/or as an anti-nociceptive, i.e., anti-pain or analgesic, agent. The selection of agents from these classes of compounds is tailored for the particular application.

Several preferred embodiments of the solution of the present invention also include anti-spasm agents for particular applications. For example, anti-spasm agents may be included alone or in combination with anti-pain/anti-inflammation agents in solutions used for vascular procedures to limit vasospasm, and anti-spasm agents may be included for urologic procedures to limit spasm in the urinary tract and bladder wall. For such applications, anti-spasm agents are utilized in the solution. For example, an anti-pain/anti-inflammation agent which also serves as an anti-spasm agent may be included. Suitable anti-inflammatory/anti-pain agents which also act as anti-spasm agents include serotonin receptor antagonists, tachykinin receptor antagonists, and ATP-sensitive potassium channel openers. Other agents which may be utilized in the solution specifically for their anti-spasm properties include calcium channel antagonists, endothelin receptor antagonists and the nitric oxide donors (enzyme activators).

Specific preferred embodiments of the solution of the present invention for use in cardiovascular and general vascular procedures include anti-restenosis agents, which most preferably are used in combination with anti-spasm agents. Suitable anti-restenosis agents include: (1) antiplatelet agents including: (a) thrombin inhibitors and receptor antagonists, (b) adenosine disphosphate (ADP) receptor antagonists (also known as purinoceptor₁ receptor antagonists), (c) thromboxane inhibitors and receptor antagonists and (d) platelet membrane glycoprotein receptor antagonists; (2) inhibitors of cell adhesion molecules, including (a) selectin inhibitors

and (b) integrin inhibitors; (3) anti-chemotactic agents; (4) interleukin receptor antagonists (which also serve as anti-pain/anti-inflammation agents); and (5) intracellular signaling inhibitors including: (a) protein kinase C (PKC) inhibitors and protein tyrosine kinase inhibitors, (b) modulators of intracellular protein tyrosine phosphatases, (c) inhibitors of src homology₂ (SH2) domains, and (d) calcium channel antagonists. Such agents are useful in preventing restenosis of arteries treated by angioplasty, rotational atherectomy or other cardiovascular or general vascular therapeutic or diagnostic procedure.

The present invention also provides a method for manufacturing a medicament compounded as a dilute irrigation solution for use in continuously irrigating an operative site or wound during an operative procedure. The method entails dissolving in a physiologic electrolyte carrier fluid at least one COX-2 inhibitor and, optionally, a plurality of anti-pain/anti-inflammatory agents, and for some applications anti-spasm agents and/or anti-restenosis agents, each agent included at a concentration of preferably no more than 100,000 nanomolar, and more preferably no more than 10,000 nanomolar.

The method of the present invention provides for the delivery of a dilute combination of multiple receptor antagonists and agonists and enzyme inhibitors and activators directly to a wound or operative site, during therapeutic or diagnostic procedures for the inhibition of pain, inflammation, spasm and restenosis. Since the active ingredients in the solution are being locally applied directly to the operative tissues in a continuous fashion, the drugs may be used efficaciously at extremely low doses relative to those doses required for therapeutic effect when the same drugs are delivered orally, intramuscularly, subcutaneously or intravenously. As used herein, the term "local" encompasses application of a drug in and around a wound or other operative site, and excludes oral, subcutaneous, intravenous and intramuscular administration. The term "continuous" as used herein encompasses uninterrupted application, repeated application at frequent intervals (e.g., repeated intravascular boluses at frequent intervals intraprocedurally), and applications which are uninterrupted except for brief cessations such as to permit the introduction of other drugs or agents or procedural equipment, such that a substantially constant predetermined concentration is maintained locally at the wound or operative site.

The advantages of low dose applications of agents are three-fold. The most important is the absence of systemic side effects which often limit the usefulness of these agents. Additionally, the agents selected for particular applications in the solutions of the present invention are highly specific with regard to the mediators on

which they work. This specificity is maintained by the low dosages utilized. Finally, the cost of these active agents per operative procedure is low.

The advantages of local administration of the agents via luminal irrigation or other fluid application are the following: (1) local administration guarantees a known concentration at the target site, regardless of interpatient variability in metabolism, blood flow, etc.; (2) because of the direct mode of delivery, a therapeutic concentration is obtained instantaneously and, thus, improved dosage control is provided; and (3) local administration of the active agents directly to a wound or operative site also substantially reduces degradation of the agents through extracellular processes, e.g., first- and second-pass metabolism, that would otherwise occur if the agents were given orally, intravenously, subcutaneously or intramuscularly. This is particularly true for those active agents that are peptides, which are metabolized rapidly. Thus, local administration permits the use of compounds or agents which otherwise could not be employed therapeutically. For example, some agents in the following classes are peptidic: bradykinin receptor antagonists; tachykinin receptor antagonists; opioid receptor agonists; CGRP receptor antagonists; and interleukin receptor antagonists. Local, continuous delivery to the wound or operative site minimizes drug degradation or metabolism while also providing for the continuous replacement of that portion of the agent that may be degraded, to ensure that a local therapeutic concentration, sufficient to maintain receptor occupancy, is maintained throughout the duration of the operative procedure.

Local administration of the solution perioperatively throughout a surgical procedure in accordance with the present invention produces a preemptive analgesic, anti-inflammatory, anti-spasmodic or anti-restenotic effect. As used herein, the term "perioperative" encompasses application intraprocedurally, pre- and intraprocedurally, intra- and postprocedurally, and pre-, intra- and postprocedurally. To maximize the preemptive anti-inflammatory, analgesic (for certain applications), antispasmodic (for certain applications) and antirestenotic (for certain applications) effects, the solutions of the present invention are most preferably applied pre-, intra- and postoperatively. By occupying the target receptors or inactivating or activating targeted enzymes prior to the initiation of significant operative trauma locally, the agents of the present solution modulate specific pathways to preemptively inhibit the targeted pathologic process. If inflammatory mediators and processes are preemptively inhibited in accordance with the present invention before they can exert

tissue damage, the benefit is more substantial than if given after the damage has been initiated.

Inhibiting more than one inflammatory, spasm or restenosis mediator by application of the multiple agent solution of the present invention has been shown to dramatically reduce the degree of inflammation, pain, and spasm, and theoretically should reduce restenosis. The irrigation solutions of the present invention include combinations of drugs, each solution acting on multiple receptors or enzymes. The drug agents are thus simultaneously effective against a combination of pathologic processes, including pain and inflammation, vasospasm, smooth muscle spasm and restenosis. The action of these agents is considered to be synergistic, in that the multiple receptor antagonists and inhibitory agonists of the present invention provide a disproportionately increased efficacy in combination relative to the efficacy of the individual agents. The synergistic action of several of the agents of the present invention are discussed, by way of example, below in the detailed descriptions of those agents.

In addition to arthroscopy, the solution of the present invention may also be applied locally to any human body cavity or passage, operative wound, traumatic wound (e.g., burns) or in any operative/interventional procedure in which irrigation can be performed. These procedures include, but are not limited to, urological procedures, cardiovascular and general vascular diagnostic and therapeutic procedures, endoscopic procedures and oral, dental and periodontal procedures. As used hereafter, the term "wound", unless otherwise specified, is intended to include surgical wounds, operative/interventional sites, traumatic wounds and burns.

Used perioperatively, the solution should result in a clinically significant decrease in operative site pain and inflammation relative to currently-used irrigation fluids, thereby decreasing the patient's postoperative analgesic (i.e., opiate) requirement and, where appropriate, allowing earlier patient mobilization of the operative site. No extra effort on the part of the surgeon and operating room personnel is required to use the present solution relative to conventional irrigation fluids.

IV. Brief Description of the Drawings

The present invention will now be described in greater detail, by way of example, with reference to the accompanying drawings in which:

FIGURE 1 provides a schematic overview of a generic vascular cell showing molecular targets and flow of signaling information leading to contraction, secretion

and/or proliferation. The integration of extrinsic signals through receptors, ion channels and other membrane proteins are common to platelets, neutrophils, endothelial cells and smooth muscle cells. Representative examples of molecular targets are included for major groups of molecules which are therapeutic targets of drugs included in the solutions of the present invention.

FIGURE 2 provides a detailed diagram of the signaling pathways illustrating "crosstalk" between G-protein coupled receptor (GPCR) pathways and receptor tyrosine kinase (RTK) pathways in a vascular smooth muscle cell. Only representative proteins in each pathway have been shown to simplify the flow of information. Activation of GPCRs leads to increases in intracellular calcium and increased protein kinase C (PKC) activity and subsequent smooth muscle contraction or spasm. In addition, "crosstalk" to the RTK signaling pathway occurs through activation of PYK2 (a newly discovered protein tyrosine kinase) and PTK-X (an undefined protein tyrosine kinase), triggering proliferation. Conversely, while activation of RTKs directly initiates proliferation, "crosstalk" to the GPCR pathway occurs at the level of PKC activity and calcium levels. LGR designates ligand-gated receptor, and MAPK designates mitogen-activated protein kinase. These interactions define the basis for synergistic interactions between molecular targets mediating spasm and restenosis. The GPCR signaling pathway also mediates signal transduction (FIGURES 3 and 7) leading to pain transmission in other cell types (e.g., neurons).

FIGURE 3 provides a diagram of the G-Protein Coupled Receptor (GPCR) pathway. Specific molecular sites of action for some drugs in a preferred arthroscopic solution of the present invention are identified.

FIGURE 4 provides a diagram of the G-Protein Coupled Receptor (GPCR) pathway including the signaling proteins responsible for "crosstalk" with the Growth Factor Receptor signaling pathway. Specific molecular sites of action for some drugs in a preferred cardiovascular and general vascular solution of the present invention are identified. (See also FIGURE 5).

FIGURE 5 provides a diagram of the Growth Factor Receptor signaling pathway including the signaling proteins responsible for "crosstalk" with the G-Protein Coupled Receptor signaling pathway. Specific molecular sites of action for some drugs in a preferred cardiovascular and general vascular solution of the present invention are identified. (See also FIGURE 4).

FIGURE 6 provides a diagram of the G-Protein Coupled Receptor pathway including the signaling proteins responsible for "crosstalk" with the Growth Factor

Receptor signaling pathway. Specific molecular sites of action for some drugs in a preferred urologic solution are identified.

FIGURE 7 provides a diagram of the G-Protein Coupled Receptor pathway. Specific molecular sites of action for some drugs in a preferred general surgical wound solution of the present invention are identified.

FIGURE 8 provides a diagram of the mechanism of action of nitric oxide (NO) donor drugs and NO causing relaxation of vascular smooth muscle. Physiologically, certain hormones and transmitters can activate a form of NO synthase in the endothelial cell through elevated intracellular calcium resulting in increased synthesis of NO. NO donors may generate NO extracellularly or be metabolized to NO within the smooth muscle cell. Extracellular NO can diffuse across the endothelial cell or directly enter the smooth muscle cell. The primary target of NO is the soluble guanylate cyclase (GC), leading to activation of a cGMP-dependent protein kinase (PKG) and subsequent extrusion of calcium from the smooth muscle cell via a membrane pump. NO also hyperpolarizes the cell by opening potassium channels which in turn cause closure of voltage-sensitive calcium channels. Thus, the synergistic interactions of calcium channel antagonists, potassium channel openers and NO donors are evident from the above signal transduction pathway.

FIGURES 9, 10A and 10B provide charts of the percent of vasoconstriction versus time in control arteries, in the proximal segment of subject arteries, and in the distal segment of subject arteries, respectively, for the animal study described in EXAMPLE VII herein demonstrating the effect on vasoconstriction of infusion with histamine and serotonin antagonists, used in the solutions of the present invention, during balloon angioplasty. FIGURES 11 and 12 provide charts of plasma extravasation versus dosage of amitriptyline, used in the solutions of the present invention, delivered intravenously and intra-articularly, respectively, to knee joints in which extravasation has been induced by introduction of 5-hydroxytryptamine in the animal study described in EXAMPLE VIII herein.

FIGURES 13, 14 and 15 provide charts of mean vasoconstriction (negative values) or vasodilation (positive values), ± 1 standard error of the mean for the proximal (FIGURE 13), mid (FIGURE 14) and distal (FIGURE 15) segments of arteries treated with saline (N=4) or with a solution formulated in accordance with the present invention (N=7), at the immediate and 15 minute post-rotational atherectomy time points in the animal study of Example XIII described herein.

V. Detailed Description of the Preferred Embodiment

The irrigation solution of the present invention is a dilute solution of multiple pain/inflammation inhibitory agents, anti-spasm agents and anti-restenosis agents in a physiologic carrier. The carrier is a liquid, which as used herein is intended to encompass biocompatible solvents, suspensions, polymerizable and non-polymerizable gels, pastes and salves. Preferably the carrier is an aqueous solution which may include physiologic electrolytes, such as normal saline or lactated Ringer's solution.

The anti-inflammation/anti-pain agents are selected from the group consisting of: (1) serotonin receptor antagonists; (2) serotonin receptor agonists; (3) histamine receptor antagonists; (4) bradykinin receptor antagonists; (5) kallikrein inhibitors; (6) tachykinin receptor antagonists, including neurokinin₁ and neurokinin₂ receptor subtype antagonists; (7) calcitonin gene-related peptide (CGRP) receptor antagonists; (8) interleukin receptor antagonists; (9) inhibitors of enzymes active in the synthetic pathway for arachidonic acid metabolites, including (a) phospholipase inhibitors, including PLA₂ isoform inhibitors and PLC_γ isoform inhibitors (b) cyclooxygenase inhibitors, and (c) lipooxygenase inhibitors; (10) prostanoid receptor antagonists including eicosanoid EP-1 and EP-4 receptor subtype antagonists and thromboxane receptor subtype antagonists; (11) leukotriene receptor antagonists including leukotriene B₄ receptor subtype antagonists and leukotriene D₄ receptor subtype antagonists; (12) opioid receptor agonists, including μ-opioid, δ-opioid, and κ-opioid receptor subtype agonists; (13) purinoceptor agonists and antagonists including P_{2X} receptor antagonists and P_{2Y} receptor agonists; and (14) adenosine triphosphate (ATP)-sensitive potassium channel openers.

Suitable anti-inflammatory/anti-pain agents which also act as anti-spasm agents include serotonin receptor antagonists, tachykinin receptor antagonists, ATP-sensitive potassium channel openers and calcium channel antagonists. Other agents which may be utilized in the solution specifically for their anti-spasm properties including endothelin receptor antagonists, calcium channel antagonists and the nitric oxide donors (enzyme activators).

Specific preferred embodiments of the solution of the present invention for use in cardiovascular and general vascular procedures include anti-restenosis agents, which most preferably are used in combination with anti-spasm agents. Suitable anti-restenosis agents include: (1) antiplatelet agents including: (a) thrombin inhibitors and receptor antagonists, (b) adenosine diphosphate (ADP) receptor

antagonists (also known as purinoceptor₁ receptor antagonists), (c) thromboxane inhibitors and receptor antagonists and (d) platelet membrane glycoprotein receptor antagonists; (2) inhibitors of cell adhesion molecules, including (a) selectin inhibitors and (b) integrin inhibitors; (3) anti-chemotactic agents; (4) interleukin receptor antagonists (which also serve as anti-pain/anti-inflammation agents); and (5) intracellular signaling inhibitors including: (a) protein kinase C (PKC) inhibitors and protein tyrosine phosphatases, (b) modulators of intracellular protein tyrosine kinase inhibitors, (c) inhibitors of src homology₂ (SH2) domains, and (d) calcium channel antagonists. Such agents are useful in preventing restenosis of arteries treated by angioplasty, rotational atherectomy or other cardiovascular or general vascular therapeutic procedure.

In each of the surgical solutions of the present invention, the agents are included in low concentrations and are delivered locally in low doses relative to concentrations and doses required with conventional methods of drug administration to achieve the desired therapeutic effect. It is impossible to obtain an equivalent therapeutic effect by delivering similarly dosed agents via other (i.e., intravenous, subcutaneous, intramuscular or oral) routes of drug administration since drugs given systemically are subject to first- and second-pass metabolism. The concentration of each agent is determined in part based on its dissociation constant, K_d . As used herein, the term dissociation constant is intended to encompass both the equilibrium dissociation constant for its respective agonist-receptor or antagonist-receptor interaction and the equilibrium inhibitory constant for its respective activator-enzyme or inhibitor-enzyme interaction. Each agent is preferably included at a low concentration of 0.1 to 10,000 times K_d nanomolar, except for cyclooxygenase inhibitors, which may be required at larger concentrations depending on the particular inhibitor selected. Preferably, each agent is included at a concentration of 1.0 to 1,000 times K_d nanomolar and most preferably at approximately 100 times K_d nanomolar. These concentrations are adjusted as needed to account for dilution in the absence of metabolic transformation at the local delivery site. The exact agents selected for use in the solution, and the concentration of the agents, varies in accordance with the particular application, as described below.

A solution in accordance with the present invention can include just a single or multiple pain/inflammation inhibitory agent(s), a single or multiple anti-spasm agent(s), a combination of both anti-spasm and pain/inflammation inhibitory agents, or anti-restenosis agents from the enumerated classes, at low concentration. However, due to the aforementioned synergistic effect of multiple agents, and the

desire to broadly block pain and inflammation, spasm and restenosis, it is preferred that multiple agents be utilized.

The surgical solutions constitute a novel therapeutic approach by combining multiple pharmacologic agents acting at distinct receptor and enzyme molecular targets. To date, pharmacologic strategies have focused on the development of highly specific drugs that are selective for individual receptor subtypes and enzyme isoforms that mediate responses to individual signaling neurotransmitters and hormones. As an example, endothelin peptides are some of the most potent vasoconstrictors known. Selective antagonists that are specific for subtypes of endothelin (ET) receptors are being sought by several pharmaceutical companies for use in the treatment of numerous disorders involving elevated endothelin levels in the body. Recognizing the potential role of the receptor subtype ET_A in hypertension, these drug companies specifically are targeting the development of selective antagonists to the ET_A receptor subtype for the anticipated treatment of coronary vasospasm. This standard pharmacologic strategy, although well accepted, is not optimal since many other vasoconstrictor agents (e.g., serotonin, prostaglandin, eicosanoid, etc.) simultaneously may be responsible for initiating and maintaining a vasospastic episode (see FIGURES 2 and 4). Furthermore, despite inactivation of a single receptor subtype or enzyme, activation of other receptor subtypes or enzymes and the resultant signal transmission often can trigger a cascade effect. This explains the significant difficulty in employing a single receptor-specific drug to block a pathophysiologic process in which multiple transmitters play a role. Therefore, targeting only a specific individual receptor subtype, such as ET_A, is likely to be ineffective.

In contrast to the standard approach to pharmacologic therapy, the therapeutic approach of the present surgical solutions is based on the rationale that a combination of drugs acting simultaneously on distinct molecular targets is required to inhibit the full spectrum of events that underlie the development of a pathophysiologic state. Furthermore, instead of targeting a specific receptor subtype alone, the surgical solutions are composed of drugs that target common molecular mechanisms operating in different cellular physiologic processes involved in the development of pain, inflammation, vasospasm, smooth muscle spasm and restenosis (see FIGURE 1). In this way, the cascading of additional receptors and enzymes in the nociceptive, inflammatory, spasmodic and restenotic pathways is minimized by the surgical solutions. In these pathophysiologic pathways, the surgical solutions inhibit the cascade effect both "upstream" and "downstream".

An example of "upstream" inhibition is the cyclooxygenase antagonists in the setting of pain and inflammation. The cyclooxygenase enzymes (COX₁ and COX₂) catalyze the conversion of arachidonic acid to prostaglandin H₂ which is an intermediate in the biosynthesis of inflammatory and nociceptive mediators including prostaglandins, leukotrienes, and thromboxanes. The cyclooxygenase inhibitors block "upstream" the formation of these inflammatory and nociceptive mediators. This strategy precludes the need to block the interactions of the seven described subtypes of prostanoid receptors with their natural ligands. A similar "upstream" inhibitor included in the surgical solutions is aprotinin, a kallikrein inhibitor. The enzyme kallikrein, a serine protease, cleaves the high molecular weight kininogens in plasma to produce bradykinins, important mediators of pain and inflammation. By inhibition of kallikrein, aprotinin effectively inhibits the synthesis of bradykinins, thereby providing an effective "upstream" inhibition of these inflammatory mediators.

The surgical solutions also make use of "downstream" inhibitors to control the pathophysiologic pathways. In vascular smooth muscle preparations that have been precontracted with a variety of neurotransmitters (e.g., serotonin, histamine, endothelin, and thromboxane) implicated in coronary vasospasm, ATP-sensitive potassium channel openers (KCOs) produce smooth muscle relaxation which is concentration dependent (Quast et al., 1994; Kashiwabara et al., 1994). The KCOs, therefore, provide a significant advantage to the surgical solutions in the settings of vasospasm and smooth muscle spasm by providing "downstream" antispasmodic effects that are independent of the physiologic combination of agonists initiating the spasmodic event (see FIGURES 2 and 4). Similarly, NO donors and voltage-gated calcium channel antagonists can limit vasospasm and smooth muscle spasm initiated by multiple mediators known to act earlier in the spasmodic pathway.

The following is a description of suitable drugs falling in the aforementioned classes of anti-inflammation/anti-pain agents, as well as suitable concentrations for use in solutions, of the present invention. While not wishing to be limited by theory, the justification behind the selection of the various classes of agents which is believed to render the agents operative is also set forth.

A. Serotonin Receptor Antagonists

Serotonin (5-HT) is thought to produce pain by stimulating serotonin₂ (5-HT₂) and/or serotonin₃ (5-HT₃) receptors on nociceptive neurons in the periphery. Most researchers agree that 5-HT₃ receptors on peripheral nociceptors mediate the

immediate pain sensation produced by 5-HT (Richardson et al., 1985). In addition to inhibiting 5-HT-induced pain, 5-HT₃ receptor antagonists, by inhibiting nociceptor activation, also may inhibit neurogenic inflammation. Barnes P.J., et. al., *Modulation of Neurogenic Inflammation: Novel Approaches to Inflammatory Disease*, Trends in Pharmacological Sciences 11, pp. 185-189 (1990). A study in rat ankle joints, however, claims the 5-HT₂ receptor is responsible for nociceptor activation by 5-HT. Grubb, B.D., et. al., *A Study of 5-HT-Receptors Associated with Afferent Nerves Located in Normal and Inflamed Rat Ankle Joints*, Agents Actions 25, pp. 216-18 (1988). Therefore, activation of 5-HT₂ receptors also may play a role in peripheral pain and neurogenic inflammation.

One goal of the solution of the present invention is to block pain and a multitude of inflammatory processes. Thus, 5-HT₂ and 5-HT₃ receptor antagonists are both suitably used, either individually or together, in the solution of the present invention, as shall be described subsequently. Amitriptyline (Elavil™) is a suitable 5-HT₂ receptor antagonist for use in the present invention. Amitriptyline has been used clinically for numerous years as an anti-depressant, and is found to have beneficial effects in certain chronic pain patients. Metoclopramide (Reglan™) is used clinically as an anti-emetic drug, but displays moderate affinity for the 5-HT₃ receptor and can inhibit the actions of 5-HT at this receptor, possibly inhibiting the pain due to 5-HT release from platelets. Thus, it also is suitable for use in the present invention.

Other suitable 5-HT₂ receptor antagonists include imipramine, trazodone, desipramine and ketanserin. Ketanserin has been used clinically for its anti-hypertensive effects. Hedner, T., et. al., *Effects of a New Serotonin Antagonist, Ketanserin, in Experimental and Clinical Hypertension*, Am J of Hypertension, pp. 317s-23s (Jul. 1988). Other suitable 5-HT₃ receptor antagonists include cisapride and ondansetron. The cardiovascular and general vascular solution also may contain a serotonin_{1B} (also known as serotonin_{1Dβ}) antagonist because serotonin has been shown to produce significant vascular spasm via activation of the serotonin_{1B} receptors in humans. Kaumann, A.J., et al., *Variable Participation of 5-HT₁-Like Receptors and 5-HT₂ Receptors in Serotonin-Induced Contraction of Human Isolated Coronary Arteries*, Circulation 90, pp. 1141-53 (1994). Suitable serotonin_{1B} receptor antagonists include yohimbine, N-[methoxy-3-(4-methyl-1-piperanzinyl)phenyl]-2'-methyl-4'-(5-methyl-1, 2, 4-oxadiazol-3-yl)[1, 1-biphenyl]-4-carboxamide ("GR127935") and methiothepin. Therapeutic and preferred

concentrations for use of these drugs in the solution of the present invention are set forth in Table 1.

Table 1Therapeutic and Preferred Concentrations ofPain/Inflammation Inhibitory Agents

<u>Class of Agent</u>	<u>Therapeutic Concentrations (Nanomolar)</u>	<u>Preferred Concentrations (Nanomolar)</u>
<u>Serotonin₂ Receptor Antagonists:</u>		
amitriptyline	0.1 - 1,000	50 - 500
imipramine	0.1 - 1,000	50 - 500
trazodone	0.1 - 2,000	50 - 500
desipramine	0.1 - 1,000	50 - 500
ketanserin	0.1 - 1,000	50 - 500
<u>Serotonin₃ Receptor Antagonists:</u>		
tropisetron	0.01 - 100	0.05 - 50
metoclopramide	10 - 10,000	200 - 2,000
cisapride	0.1 - 1,000	20 - 200
ondansetron	0.1 - 1,000	20 - 200
<u>Serotonin_{1B} (Human 1D_β) Antagonists:</u>		
yohimbine	0.1 - 1,000	50 - 500
GR127935	0.1 - 1,000	10 - 500
methiothepin	0.1 - 500	1 - 100

5 B. Serotonin Receptor Agonists

5-HT_{1A}, 5-HT_{1B} and 5-HT_{1D} receptors are known to inhibit adenylate cyclase activity. Thus including a low dose of these serotonin_{1A}, serotonin_{1B} and

serotonin_{1D} receptor agonists in the solution should inhibit neurons mediating pain and inflammation. The same action is expected from serotonin_{1E} and serotonin_{1F} receptor agonists because these receptors also inhibit adenylate cyclase.

- Buspirone is a suitable 1A receptor agonist for use in the present invention.
- 5 Sumatriptan is a suitable 1A, 1B, 1D and 1F receptor agonist. A suitable 1B and 1D receptor agonist is dihydroergotamine. A suitable 1E receptor agonist is ergonovine. Therapeutic and preferred concentrations for these receptor agonists are provided in Table 2.

Table 2Therapeutic and Preferred Concentrations ofPain/Inflammation Inhibitory Agents

<u>Class of Agent</u>	<u>Therapeutic Concentrations (Nanomolar)</u>	<u>Preferred Concentrations (Nanomolar)</u>
<u>Serotonin_{1A} Agonists:</u>		
buspirone	1 - 1,000	10 - 200
sumatriptan	1 - 1,000	10 - 200
<u>Serotonin_{1B} Agonists:</u>		
dihydroergotamine	0.1 - 1,000	10 - 100
sumatriptan	1 - 1,000	10 - 200
<u>Serotonin_{1D} Agonists:</u>		
dihydroergotamine	0.1 - 1,000	10 - 100
sumatriptan	1 - 1,000	10 - 200
<u>Serotonin_{1E} Agonists:</u>		
ergonovine	10 - 2,000	100 - 1,000
<u>Serotonin_{1F} Agonists:</u>		
sumatriptan	1 - 1,000	10 - 200

C. Histamine Receptor Antagonists

- 5 Histamine receptors generally are divided into histamine₁ (H₁) and histamine₂ (H₂) subtypes. The classic inflammatory response to the peripheral administration of histamine is mediated via the H₁ receptor. Douglas, 1985. Therefore, the solution of the present invention preferably includes a histamine H₁ receptor antagonist. Promethazine (PhenerganTM) is a commonly used anti-emetic
- 10 drug which potently blocks H₁ receptors, and is suitable for use in the present invention. Interestingly, this drug also has been shown to possess local anesthetic

effects but the concentrations necessary for this effect are several orders higher than that necessary to block H₁ receptors, thus, the effects are believed to occur by different mechanisms. The histamine receptor antagonist concentration in the solution is sufficient to inhibit H₁ receptors involved in nociceptor activation, but not to achieve a "local anesthetic" effect, thereby eliminating the concern regarding systemic side effects.

Histamine receptors also are known to mediate vasomotor tone in the coronary arteries. *In vitro* studies in the human heart have demonstrated that the histamine₁ receptor subtype mediates contraction of coronary smooth muscle. Ginsburg, R., et al., *Histamine Provocation of Clinical Coronary Artery Spasm: Implications Concerning Pathogenesis of Variant Angina Pectoris*, American Heart J., Vol. 102, pp. 819-822, (1980). Some studies suggest that histamine-induced hypercontractility in the human coronary system is most pronounced in the proximal arteries in the setting of atherosclerosis and the associated denudation of the arterial endothelium. Keitoku, M. et al., *Different Histamine Actions in Proximal and Distal Human Coronary Arteries in Vitro*, Cardiovascular Research 24, pp. 614-622, (1990). Therefore, histamine receptor antagonists may be included in the cardiovascular irrigation solution.

Other suitable H₁ receptor antagonists include terfenadine, diphenhydramine, amitriptyline, mepyramine and triprolidine. Because amitriptyline is also effective as a serotonin₂ receptor antagonist, it has a dual function as used in the present invention. Suitable therapeutic and preferred concentrations for each of these H₁ receptor antagonists are set forth in Table 3.

Table 3Therapeutic and Preferred Concentrations ofPain/Inflammation Inhibitory Agents

<u>Class of Agent</u>	<u>Therapeutic Concentrations (Nanomolar)</u>	<u>Preferred Concentrations (Nanomolar)</u>
<u>Histamine₁ Receptor Antagonists:</u>		
promethazine	0.1 - 1,000	50 - 200
diphenhydramine	0.1 - 1,000	50 - 200
amitriptyline	0.1 - 1,000	50 - 500
terfenadine	0.1 - 1,000	50 - 500
mepyramine (pyrilamine)	0.1 - 1,000	5 - 200
tripolidine	0.01 - 100	5 - 20

D. Bradykinin Receptor Antagonists

5 Bradykinin receptors generally are divided into bradykinin₁ (B₁) and bradykinin₂ (B₂) subtypes. Studies have shown that acute peripheral pain and inflammation produced by bradykinin are mediated by the B₂ subtype whereas bradykinin-induced pain in the setting of chronic inflammation is mediated via the B₁ subtype. Perkins, M.N., et. al., *Antinociceptive Activity of the Bradykinin B₁ and*
10 *B₂ Receptor Antagonists, des-Arg⁹, [Leu⁸]-BK and HOE 140, in Two Models of Persistent Hyperalgesia in the Rat*, Pain 53, pp. 191-97 (1993); Dray, A., et. al., *Bradykinin and Inflammatory Pain*, Trends Neurosci 16, pp. 99-104 (1993), each of which references is hereby expressly incorporated by reference.

At present, bradykinin receptor antagonists are not used clinically. These
15 drugs are peptides (small proteins), and thus they cannot be taken orally, because they would be digested. Antagonists to B₂ receptors block bradykinin-induced acute pain and inflammation. Dray et. al., 1993. B₁ receptor antagonists inhibit pain in chronic inflammatory conditions. Perkins et al., 1993; Dray et. al., 1993. Therefore, depending on the application, the solution of the present invention preferably
20 includes either or both bradykinin B₁ and B₂ receptor antagonists. For example,

arthroscopy is performed for both acute and chronic conditions, and thus an irrigation solution for arthroscopy could include both B₁ and B₂ receptor antagonists.

Suitable bradykinin receptor antagonists for use in the present invention include the following bradykinin₁ receptor antagonists: the [des-Arg¹⁰] derivative of D-Arg-(Hyp³-Thi⁵-D-Tic⁷-Oic⁸)-BK ("the [des-Arg¹⁰] derivative of HOE 140", available from Hoechst Pharmaceuticals); and [Leu⁸] des-Arg⁹-BK. Suitable bradykinin₂ receptor antagonists include: [D-Phe⁷]-BK; D-Arg-(Hyp³-Thi^{5,8}-D-Phe⁷)-BK ("NPC 349"); D-Arg-(Hyp³-D-Phe⁷)-BK ("NPC 567"); and D-Arg-(Hyp³-Thi⁵-D-Tic⁷-Oic⁸)-BK ("HOE 140"). These compounds are more fully described in the previously incorporated Perkins et. al. 1993 and Dray et. al. 1993 references. Suitable therapeutic and preferred concentrations are provided in Table 4.

Table 4

Therapeutic and Preferred Concentrations of

15

Pain/Inflammation Inhibitory Agents

<u>Class of Agent</u>	<u>Therapeutic Concentrations (Nanomolar)</u>	<u>Preferred Concentrations (Nanomolar)</u>
<u>Bradykinin₁ Receptor Antagonists:</u>		
[Leu ⁸] des-Arg ⁹ -BK	1 - 1,000	50 - 500
[des-Arg ¹⁰] derivative of HOE 140	1 - 1,000	50 - 500
[leu ⁹] [des-Arg ¹⁰] kalliden	0.1 - 500	10 - 200
<u>Bradykinin₂ Receptor Antagonists:</u>		
[D-Phe ⁷]-BK	100 - 10,000	200 - 5,000
NPC 349	1 - 1,000	50 - 500
NPC 567	1 - 1,000	50 - 500
HOE 140	1 - 1,000	50 - 500

E. Kallikrein Inhibitors

The peptide bradykinin is an important mediator of pain and inflammation, as noted previously. Bradykinin is produced as a cleavage product by the action of

kallikrein on high molecular weight kininogens in plasma. Therefore kallikrein inhibitors are believed to be therapeutic in inhibiting bradykinin production and resultant pain and inflammation. A suitable kallikrein inhibitor for use in the present invention is aprotinin. Suitable concentrations for use in the solutions of the present invention are set forth below in Table 5.

Table 5

Therapeutic and Preferred Concentrations of
Pain/Inflammation Inhibitory Agents

<u>Class of Agent</u>	<u>Therapeutic Concentrations (Nanomolar)</u>	<u>Preferred Concentrations (Nanomolar)</u>
<u>Kallikrein Inhibitor:</u>		
Aprotinin	0.1 - 1,000	50 - 500

10 F. Tachykinin Receptor Antagonists

Tachykinins (TKs) are a family of structurally related peptides that include substance P, neurokinin A (NKA) and neurokinin B (NKB). Neurons are the major source of TKs in the periphery. An important general effect of TKs is neuronal stimulation, but other effects include endothelium-dependent vasodilation, plasma protein extravasation, mast cell recruitment and degranulation and stimulation of inflammatory cells. Maggi, C.A., *Gen. Pharmacol.*, Vol. 22, pp. 1-24 (1991). Due to the above combination of physiological actions mediated by activation of TK receptors, targeting of TK receptors is a reasonable approach for the promotion of analgesia and the treatment of neurogenic inflammation.

20 1. Neurokinin₁ Receptor Subtype Antagonists

Substance P activates the neurokinin receptor subtype referred to as NK₁. Substance P is an undecapeptide that is present in sensory nerve terminals. Substance P is known to have multiple actions which produce inflammation and pain in the periphery after C-fiber activation, including vasodilation, plasma extravasation and degranulation of mast cells. Levine, J.D., et. al., *Peptides and the Primary Afferent Nociceptor*, *J. Neurosci.* 13, p. 2273 (1993). A suitable Substance P antagonist is ([D-Pro⁹[spiro-gamma-lactam]Leu¹⁰,Trp¹¹]physalaemin-(1-11)) ("GR

82334”). Other suitable antagonists for use in the present invention which act on the NK₁ receptor are: 1-imino-2-(2-methoxy-phenyl)-ethyl)-7,7-diphenyl-4-perhydroisoindolone(3aR,7aR) (“RP 67580”); and 2S,3S-cis-3-(2-methoxybenzylamino)-2-benzhydrylquinuclidine (“CP 96,345”). Suitable concentrations for these agents are set forth in Table 6.

Table 6

Therapeutic and Preferred Concentrations of Pain/Inflammation Inhibitory Agents

<u>Class of Agent</u>	<u>Therapeutic Concentrations (Nanomolar)</u>	<u>Preferred Concentrations (Nanomolar)</u>
<u>Neurokinin₁ Receptor Subtype Antagonists</u>		
GR 82334	1 - 1,000	10 - 500
CP 96,345	1-10,000	100-1,000
RP 67580	0.1-1,000	100-1,000

10

2. Neurokinin₂ Receptor Subtype Antagonists

Neurokinin A is a peptide which is colocalized in sensory neurons with substance P and which also promotes inflammation and pain. Neurokinin A activates the specific neurokinin receptor referred to as NK₂. Edmonds-Alt, S., et. al., *A Potent and Selective Non-Peptide Antagonist of the Neurokinin A (NK₂) Receptor*, Life Sci. 50:PL101 (1992). In the urinary tract, TKs are powerful spasmogens acting through only the NK₂ receptor in the human bladder, as well as the human urethra and ureter. Maggi, C.A., *Gen. Pharmacol.*, Vol. 22, pp. 1-24 (1991). Thus, the desired drugs for inclusion in a surgical solution for use in urological procedures would contain an antagonist to the NK₂ receptor to reduce spasm. Examples of suitable NK₂ antagonists include: ((S)-N-methyl-N-[4-(4-acetylamino-4-phenylpiperidino)-2-(3,4-dichlorophenyl)butyl]benzamide (“(±)-SR 48968”); Met-Asp-Trp-Phe-Dap-Leu (“MEN 10,627”); and cyc(Gln-Trp-Phe-Gly-Leu-Met) (“L 659,877”). Suitable concentrations of these agents are provided in Table 7.

20

Table 7

Therapeutic and Preferred Concentrations of
Pain/Inflammation Inhibitory Agents

<u>Class of Agent</u>	<u>Therapeutic Concentrations (Nanomolar)</u>	<u>Preferred Concentrations (Nanomolar)</u>
<u>Neurokinin₂ Receptor Subtype Antagonists:</u>		
MEN 10,627	1-1,000	10-1,000
L 659,877	10-10,000	100-10,000
(±)-SR 48968	10-10,000	100-10,000

5 G. CGRP Receptor Antagonists

10 Calcitonin gene-related peptide (CGRP) is a peptide which is also colocalized in sensory neurons with substance P, and which acts as a vasodilator and potentiates the actions of substance P. Brain, S.D., et. al., *Inflammatory Oedema Induced by Synergism Between Calcitonin Gene-Related Peptide (CGRP) and Mediators of Increased Vascular Permeability*, Br. J. Pharmacol. 99, p. 202 (1985). An example of a suitable CGRP receptor antagonist is α -CGRP-(8-37), a truncated version of CGRP. This polypeptide inhibits the activation of CGRP receptors. Suitable concentrations for this agent are provided in Table 8.

Table 8

Therapeutic and Preferred Concentrations of
Pain/Inflammation Inhibitory Agents

<u>Class of Agent</u>	<u>Therapeutic Concentrations (Nanomolar)</u>	<u>Preferred Concentrations (Nanomolar)</u>
<u>CGRP Receptor Antagonist:</u>		
α -CGRP-(8-37)	1-1,000	10-500

5 H. Interleukin Receptor Antagonist

Interleukins are a family of peptides, classified as cytokines, produced by leukocytes and other cells in response to inflammatory mediators. Interleukins (IL) may be potent hyperalgesic agents peripherally. Ferriera, S.H., et. al., *Interleukin-1 β as a Potent Hyperalgesic Agent Antagonized by a Tripeptide Analogue*, Nature 334, p. 698 (1988). An example of a suitable IL-1 β receptor antagonist is Lys-D-Pro-Thr, which is a truncated version of IL-1 β . This tripeptide inhibits the activation of IL-1 β receptors. Suitable concentrations for this agent are provided in Table 9.

Table 9

Therapeutic and Preferred Concentrations of
Pain/Inflammation Inhibitory Agents

15

<u>Class of Agent</u>	<u>Therapeutic Concentrations (Nanomolar)</u>	<u>Preferred Concentrations (Nanomolar)</u>
<u>Interleukin Receptor Antagonist:</u>		
Lys-D-Pro-Thr	1-1,000	10-500

I. Inhibitors of Enzymes Active in the Synthetic Pathway
for Arachidonic Acid Metabolites

1. Phospholipase Inhibitors

The production of arachidonic acid by phospholipase A₂ (PLA₂) results in a cascade of reactions that produces numerous mediators of inflammation, know as eicosanoids. There are a number of stages throughout this pathway that can be inhibited, thereby decreasing the production of these inflammatory mediators. Examples of inhibition at these various stages are given below.

Inhibition of the enzyme PLA₂ isoform inhibits the release of arachidonic acid from cell membranes, and therefore inhibits the production of prostaglandins and leukotrienes resulting in decreased inflammation and pain. Glaser, K.B., *Regulation of Phospholipase A2 Enzymes: Selective Inhibitors and Their Pharmacological Potential*, Adv. Pharmacol. 32, p. 31 (1995). An example of a suitable PLA₂ isoform inhibitor is manoalide. Suitable concentrations for this agent are included in Table 10. Inhibition of the phospholipase C_γ (PLC_γ) isoform also will result in decreased production of prostanoids and leukotrienes, and, therefore, will result in decreased pain and inflammation. An example of a PLC_γ isoform inhibitor is 1-[6-((17β-3-methoxyestra-1,3,5(10)-trien-17-yl)amino)hexyl]-1H-pyrrole-2,5-dione.

Table 10

20 Therapeutic and Preferred Concentrations of
Pain/Inflammation Inhibitory Agents

<u>Class of Agent</u>	<u>Therapeutic Concentrations (Nanomolar)</u>	<u>Preferred Concentrations (Nanomolar)</u>
<u>PLA₂ Isoform Inhibitor:</u> manoalide	100-100,000	500-10,000

2. Cyclooxygenase Inhibitors

Nonsteroidal anti-inflammatory drugs (NSAIDs) are widely used as anti-inflammatory, anti-pyretic, anti-thrombotic and analgesic agents. Lewis, R.A., *Prostaglandins and Leukotrienes*, In: Textbook of Rheumatology, 3d ed. (Kelley W.N., et. al., eds.), p. 258 (1989). The molecular targets for these drugs are type I

and type II cyclooxygenases (COX-1 and COX-2). These enzymes are also known as Prostaglandin H Synthase (PGHS)-1 (constitutive) and -2 (inducible), and catalyze the conversion of arachidonic acid to Prostaglandin H which is an intermediate in the biosynthesis of prostaglandins and thromboxanes. The COX-2 enzyme has been
5 identified in endothelial cells, macrophages, and fibroblasts. This enzyme is induced by IL-1 and endotoxin, and its expression is upregulated at sites of inflammation. Constitutive activity of COX-1 and induced activity of COX-2 both lead to synthesis of prostaglandins which contribute to pain and inflammation.

NSAIDs currently on the market (diclofenac, naproxen, indomethacin, ibuprofen, etc.) are generally nonselective inhibitors of both isoforms of COX, but may show greater selectivity for COX-1 over COX-2, although this ratio varies for the different compounds. Use of COX-1 and 2 inhibitors to block formation of prostaglandins represents a better therapeutic strategy than attempting to block interactions of the natural ligands with the seven described subtypes of prostanoid
15 receptors. Reported antagonists of the eicosanoid receptors (EP-1, EP-2, EP-3) are quite rare and only specific, high affinity antagonists of the thromboxane A₂ receptor have been reported. Wallace, J. and Cirino, G. *Trends in Pharm. Sci.*, Vol. 15 pp. 405-406 (1994).

The oral, intravenous or intramuscular use of cyclooxygenase inhibitors is
20 contraindicated in patients with ulcer disease, gastritis or renal impairment. In the United States, the only available injectable form of this class of drugs is ketorolac (Toradol™), available from Syntex Pharmaceuticals, which is conventionally used intramuscularly or intravenously in postoperative patients but, again, is contraindicated for the above-mentioned categories of patients. The use of ketorolac,
25 or any other cyclooxygenase inhibitor(s), in the solution in substantially lower dosages than currently used perioperatively may allow the use of this drug in otherwise contraindicated patients. The addition of a cyclooxygenase inhibitor to the solutions of the present invention adds a distinct mechanism for inhibiting the production of pain and inflammation during arthroscopy or other therapeutic or
30 diagnostic procedure.

Preferred cyclooxygenase inhibitors for use in the present invention are ketorolac and indomethacin. Of these two agents, indomethacin is less preferred because of the relatively high dosages required. Therapeutic and preferred concentrations for use in the solution are provided in Table 11.

Table 11

Therapeutic and Preferred Concentrations of
Pain/Inflammation Inhibitory Agents

<u>Class of Agent</u>	<u>Therapeutic Concentrations (Nanomolar)</u>	<u>Preferred Concentrations (Nanomolar)</u>
<u>Cyclooxygenase Inhibitors:</u>		
ketorolac	100 - 10,000	500 - 5,000
indomethacin	1,000 - 500,000	10,000 - 200,000

5

3. Lipooxygenase Inhibitors

Inhibition of the enzyme lipooxygenase inhibits the production of leukotrienes, such as leukotriene B₄, which is known to be an important mediator of inflammation and pain. Lewis, R.A., *Prostaglandins and Leukotrienes*, In: Textbook of Rheumatology, 3d ed. (Kelley W.N., et. al., eds.), p. 258 (1989). An example of a 5-lipooxygenase antagonist is 2,3,5-trimethyl-6-(12-hydroxy-5,10-dodecadiynyl)-1,4-benzoquinone ("AA 861"), suitable concentrations for which are listed in Table 12.

10

Table 12

Therapeutic and Preferred Concentrations of
Pain/Inflammation Inhibitory Agents

15

<u>Class of Agent</u>	<u>Therapeutic Concentrations (Nanomolar)</u>	<u>Preferred Concentrations (Nanomolar)</u>
<u>Lipooxygenase Inhibitor:</u>		
AA 861	100-10,000	500-5,000

J. Prostanoid Receptor Antagonists

Specific prostanoids produced as metabolites of arachidonic acid mediate their inflammatory effects through activation of prostanoid receptors. Examples of classes of specific prostanoid antagonists are the eicosanoid EP-1 and EP-4 receptor subtype antagonists and the thromboxane receptor subtype antagonists. A suitable

20

prostaglandin E₂ receptor antagonist is 8-chlorodibenz[b,f][1,4]oxazepine-10(11H)-carboxylic acid, 2-acetylhydrazide ("SC 19220"). A suitable thromboxane receptor subtype antagonist is [15-[1 α , 2 β (5Z), 3 β , 4 α]-7-[3-[2-(phenylamino)-carbonyl]hydrazino] methyl]-7-oxobicyclo-[2,2,1]-hept-2-yl]-5-heptanoic acid ("SQ 29548").

5 Suitable concentrations for these agents are set forth in Table 13.

Table 13

Therapeutic and Preferred Concentrations of
Pain/Inflammation Inhibitory Agents

<u>Class of Agent</u>	<u>Therapeutic Concentrations (Nanomolar)</u>	<u>Preferred Concentrations (Nanomolar)</u>
<u>Eicosanoid EP-1 Antagonist:</u>		
SC 19220	100-10,000	500-5,000

10 K. Leukotriene Receptor Antagonists

The leukotrienes (LTB₄, LTC₄, and LTD₄) are products of the 5-lipoxygenase pathway of arachidonic acid metabolism that are generated enzymatically and have important biological properties. Leukotrienes are implicated in a number of pathological conditions including inflammation. Specific antagonists are currently being sought by many pharmaceutical companies for potential therapeutic intervention in these pathologies. Halushka, P.V., et al., Annu. Rev. Pharmacol. Toxicol. 29: 213-239 (1989); Ford-Hutchinson, A. Crit. Rev. Immunol. 10: 1-12 (1990). The LTB₄ receptor is found in certain immune cells including eosinophils and neutrophils. LTB₄ binding to these receptors results in chemotaxis and lysosomal enzyme release thereby contributing to the process of inflammation. The signal transduction process associated with activation of the LTB₄ receptor involves G-protein-mediated stimulation of phosphatidylinositol (PI) metabolism and elevation of intracellular calcium (see FIGURE 2).

25 An example of a suitable leukotriene B₄ receptor antagonist is SC (+)-(S)-7-(3-(2-(cyclopropylmethyl)-3-methoxy-4-[(methylamino)-carbonyl]phenoxy(propoxy)-3,4-dihydro-8-propyl-2H-1-benzopyran-2-propanoic acid ("SC 53228"). Concentrations for this agent that are suitable for the practice of the present invention are provided in Table 14. Other suitable leukotriene B₄

receptor antagonists include [3-[2(7-chloro-2-quinolinyl)ethenyl]phenyl] [[3-(dimethylamino-3-oxopropyl)thio] methyl]thiopropionic acid ("MK 0571") and the drugs LY 66,071 and ICI 20,3219. MK 0571 also acts as a LTD₄ receptor subtype antagonist.

5

Table 14

Therapeutic and Preferred Concentrations of
Pain/Inflammation Inhibitory Agents

<u>Class of Agent</u>	<u>Therapeutic Concentrations (Nanomolar)</u>	<u>Preferred Concentrations (Nanomolar)</u>
<u>Leukotriene B₄ Antagonist:</u>		
SC 53228	100-10,000	500-5,000

L. Opioid Receptor Agonists

10 Activation of opioid receptors results in anti-nociceptive effects and, therefore, agonists to these receptors are desirable. Opioid receptors include the μ -, δ - and κ -opioid receptor subtypes. The μ -receptors are located on sensory neuron terminals in the periphery and activation of these receptors inhibits sensory neuron activity. Basbaum, A.I., et. al., *Opiate analgesia: How Central is a Peripheral*
15 *Target?*, N. Engl. J. Med., 325:1168 (1991). δ - and κ -receptors are located on sympathetic efferent terminals and inhibit the release of prostaglandins, thereby inhibiting pain and inflammation. Taiwo, Y.O., et. al., *Kappa- and Delta-Opioids Block Sympathetically Dependent Hyperalgesia*, J. Neurosci., Vol. 11, page 928
20 (1991). The opioid receptor subtypes are members of the G-protein coupled receptor superfamily. Therefore, all opioid receptor agonists interact and initiate signaling through their cognate G-protein coupled receptor (see FIGURES 3 and 7). Examples of suitable μ -opioid receptor agonists are fentanyl and Try-D-Ala-Gly-[N-MePhe]-NH(CH₂)-OH ("DAMGO"). An example of a suitable δ -opioid receptor agonist is [D-Pen²,D-Pen⁵]enkephalin ("DPDPE"). An example of a suitable κ -opioid receptor
25 agonist is (trans)-3,4-dichloro-N-methyl-N-[2-(1-pyrrolidnyl)cyclohexyl]-benzene acetamide ("U50,488"). Suitable concentrations for each of these agents are set forth in Table 15.

Table 15

Therapeutic and Preferred Concentrations of
Pain/Inflammation Inhibitory Agents

<u>Class of Agent</u>	<u>Therapeutic Concentrations (Nanomolar)</u>	<u>Preferred Concentrations (Nanomolar)</u>
<u>μ-Opioid Agonist:</u>		
DAMGO	0.1-100	0.5-20
sufentanyl	0.01-50	1-20
fentanyl	0.1-500	10-200
PL 017	0.05-50	0.25-10
<u>δ-Opioid Agonist:</u>		
DPDPE	0.1-500	1.0-100
<u>κ-Opioid Agonist:</u>		
U50,488	0.1-500	1.0-100

5 M. Purinoceptor Antagonists and Agonists

Extracellular ATP acts as a signaling molecule through interactions with P₂ purinoceptors. One major class of purinoceptors are the P_{2X} purinoceptors which are ligand-gated ion channels possessing intrinsic ion channels permeable to Na⁺, K⁺, and Ca²⁺. P_{2X} receptors described in sensory neurons are important for primary
10 afferent neurotransmission and nociception. ATP is known to depolarize sensory neurons and plays a role in nociceptor activation since ATP released from damaged cells stimulates P_{2X} receptors leading to depolarization of nociceptive nerve-fiber terminals. The P_{2X3} receptor has a highly restricted distribution (Chen, C.C., et. al., Nature, Vol. 377, pp. 428-431 (1995)) since it is selectively expressed in sensory C-
15 fiber nerves that run into the spinal cord and many of these C-fibers are known to carry the receptors for painful stimuli. Thus, the highly restricted localization of

expression for the P_{2X}₃ receptor subunits make these subtypes excellent targets for analgesic action (see FIGURES 3 and 7).

Suitable antagonists of P_{2X}/ATP purinoceptors for use in the present invention include, by way of example, suramin and pyridoxylphosphate-6-azophenyl-2,4-disulfonic acid ("PPADS"). Suitable concentrations for these agents are provided in Table 16.

Agonists of the P_{2Y} receptor, a G-protein coupled receptor, are known to effect smooth muscle relaxation through elevation of inositol triphosphate (IP₃) levels with a subsequent increase in intracellular calcium. An example of a P_{2Y} receptor agonist is 2-me-S-ATP.

Table 16

Therapeutic and Preferred Concentrations of
Pain/Inflammation Inhibitory Agents

<u>Class of Agent</u>	<u>Therapeutic Concentrations (Nanomolar)</u>	<u>Preferred Concentrations (Nanomolar)</u>
<u>Purinoceptor Antagonists:</u>		
suramin	100-100,000	10,000-100,000
PPADS	100-100,000	10,000-100,000

15 N. Adenosine Triphosphate (ATP)-Sensitive Potassium Channel Openers

ATP-sensitive potassium channels have been discovered in numerous tissues, including vascular and non-vascular smooth muscle and brain, and binding studies using radiolabeled ligands have confirmed their existence. Opening of these channels causes potassium (K⁺) efflux and hyperpolarizes the cell membrane (see 20 FIGURE 2). This hyperpolarization induces a reduction in intracellular free calcium through inhibition of voltage-dependent calcium (Ca²⁺) channels and receptor operated Ca²⁺ channels. These combined actions drive the cell (e.g., smooth muscle cell) into a relaxed state or one which is more resistant to activation and, in the case of vascular smooth muscle, results in vasorelaxation. K⁺ channel openers (KCOs) 25 have been characterized as having potent antihypertensive activity *in vivo* and vasorelaxant activity *in vitro* (see FIGURE 4). K⁺ channel openers (KCOs) also have been shown to prevent stimulus coupled secretion and are considered to act on

prejunctional neuronal receptors and thus will inhibit effects due to nerve stimulation and release of inflammatory mediators. Quast, U., et. al., *Cellular Pharmacology of Potassium Channel Openers in Vascular Smooth Muscle*, Cardiovasc. Res., Vol. 28, pp. 805-810 (1994).

5 Synergistic interactions between endothelin (ET_A) antagonists and openers of ATP-sensitive potassium channels (KCOs) are expected in achieving vasorelaxation or smooth muscle relaxation. A rationale for dual use is based upon the fact that these drugs have different molecular mechanisms of action in promoting relaxation of smooth muscle and prevention of vasospasm. An initial intracellular calcium
10 elevation in smooth muscle cells induced by the ET_A receptor subsequently triggers activation of voltage-dependent channels and the entry of extracellular calcium which is required for contraction. Antagonists of the ET_A receptor will specifically block this receptor mediated effect but not block increases in calcium triggered by activation of other G-protein coupled receptors on the muscle cell.

15 Potassium-channel opener drugs, such as pinacidil, will open these channels causing K⁺ efflux and hyperpolarization of the cell membrane. This hyperpolarization will act to reduce contraction mediated by other receptors by the following mechanisms: (1) it will induce a reduction in intracellular free calcium through inhibition of voltage-dependent Ca²⁺ channels by reducing the probability of
20 opening L-type or T-type calcium channels, (2) it will restrain agonist induced (receptor operated channels) Ca²⁺ release from intracellular sources through inhibition of inositol triphosphate (IP₃) formation, and (3) it will lower the efficiency of calcium as an activator of contractile proteins. Consequently, combined actions of these two classes of drugs will clamp the target cells into a relaxed state or one which
25 is more resistant to activation.

Suitable ATP-sensitive K⁺ channel openers for the practice of the present invention include: (-)pinacidil; cromakalim; nicorandil; minoxidil; N-cyano-N'-[1,1-dimethyl-[2,2,3,3-³H]propyl]-N''-(3-pyridinyl)guanidine ("P 1075"); and N-cyano-N'-(2-nitroxyethyl)-3-pyridinecarboximidamide monomethansulphonate ("KRN 2391").
30 Concentrations for these agents are set forth in Table 17.

Table 17

Therapeutic and Preferred Concentrations of
Pain/Inflammation Inhibitory Agents

<u>Class of Agent</u>	<u>Therapeutic Concentrations (Nanomolar)</u>	<u>Preferred Concentrations (Nanomolar)</u>
<u>ATP-Sensitive K⁺ Channel Opener:</u>		
cromakalim	10-10,000	100-10,000
nicorandil	10-10,000	100-10,000
minoxidil	10-10,000	100-10,000
P 1075	0.1-1,000	10-1,000
KRN 2391	1-10,000	100-1,000
(-)-pinacidil	1-10,000	100-1,000

I. Anti-Spasm Agents

1. Multifunction Agents

Several of the anti-pain/anti-inflammatory agents described above also serve to inhibit vasoconstriction or smooth muscle spasm. As such, these agents also perform the function of anti-spasm agents, and thus are beneficially used in vascular and urologic applications. Anti-inflammatory/anti-pain agents that also serve as anti-spasm agents include: serotonin receptor antagonists, particularly, serotonin₂ antagonists; tachykinin receptor antagonists and ATP-sensitive potassium channel openers.

2. Nitric Oxide Donors

Nitric oxide donors may be included in the solutions of the present invention particularly for their anti-spasm activity. Nitric oxide (NO) plays a critical role as a molecular mediator of many physiological processes, including vasodilation and regulation of normal vascular tone. Within endothelial cells, an enzyme known as NO synthase (NOS) catalyzes the conversion of L-arginine to NO which acts as a diffusible second messenger and mediates responses in adjacent smooth muscle cells (see FIGURE 8). NO is continuously formed and released by the vascular endothelium under basal conditions which inhibits contractions and controls basal coronary tone and is produced in the endothelium in response to various agonists (such as acetylcholine) and other endothelium dependent vasodilators. Thus,

regulation of NO synthase activity and the resultant levels of NO are key molecular targets controlling vascular tone (see FIGURE 8). Muramatsu, K., et. al., Coron. Artery Dis., Vol. 5, pp. 815-820 (1994).

5 Synergistic interactions between NO donors and openers of ATP-sensitive potassium channels (KCOs) are expected to achieve vasorelaxation or smooth muscle relaxation. A rationale for dual use is based upon the fact that these drugs have different molecular mechanisms of action in promoting relaxation of smooth muscle and prevention of vasospasm. There is evidence from cultured coronary arterial smooth muscle cells that the vasoconstrictors: vasopressin, angotensin II and
10 endothelin, all inhibit K_{ATP} currents through inhibition of protein kinase A. In addition, it has been reported that K_{ATP} current in bladder smooth muscle is inhibited by muscarinic agonists. The actions of NO in mediating smooth muscle relaxation occur via independent molecular pathways (described above) involving protein kinase G (see FIGURE 8). This suggests that the combination of the two classes of
15 agents will be more efficacious in relaxing smooth muscle than employing a single class of agent alone.

Suitable nitric oxide donors for the practice of the present invention include nitroglycerin, sodium nitroprusside, the drug FK 409, FR 144420, 3-morpholinopyridone, or linsidomine chlorohydrate, ("SIN-1"); and S-nitroso-
20 N-acetylpenicillamine ("SNAP"). Concentrations for these agents are set forth in Table 18.

Table 18

Therapeutic and Preferred Concentrations of
Spasm Inhibitory Agents

<u>Class of Agent</u>	<u>Therapeutic Concentrations (Nanomolar)</u>	<u>Preferred Concentrations (Nanomolar)</u>
<u>Nitric Oxide Donors:</u>		
Nitroglycerin	10-10,000	100-1,000
sodium nitroprusside	10-10,000	100-1,000
SIN-1	10-10,000	100-1,000
SNAP	10-10,000	100-1,000
FK 409 (NOR-3)	1-1,000	10-500
FR 144420 (NOR-4)	10 - 10,000	100 - 5,000

5

3. Endothelin Receptor Antagonists

Endothelin is a 21 amino acid peptide that is one of the most potent vasoconstrictors known. Three different human endothelin peptides, designated ET-1, ET-2 and ET-3 have been described which mediate their physiological effects through at least two receptor subtypes referred to as ET_A and ET_B receptors. The heart and vascular smooth muscle contain predominantly ET_A receptors and this subtype is responsible for contraction in these tissues. Furthermore, ET_A receptors have often been found to mediate contractile responses in isolated smooth muscle preparations. Antagonists of ET_A receptors have been found to be potent antagonists of human coronary artery contractions. Thus, antagonists to the ET_A receptor should be therapeutically beneficial in the perioperative inhibition of coronary vasospasm and may additionally be useful in inhibition of smooth muscle contraction in urological applications. Miller, R.C., et. al., Trends in Pharmacol. Sci., Vol. 14, pp. 54-60 (1993).

Suitable endothelin receptor antagonists include: cyclo(D-Asp-Pro-D-Val-Leu-D-Trp) ("BQ 123"); (N,N-hexamethylene)-carbamoyl-Leu-D-Trp-(CHO)-D-

20

Trp-OH (“BQ 610”); (R)2-([R-2-[(s)-2-([1-hexahydro-1H-azepinyl]-carbonyl)amino-4-methyl-pentanoyl) amino-3-(3[1-methyl-1H-indodyl])propionylamino-3(2-pyridyl) propionic acid (“FR 139317”); cyclo(D-Asp-Pro-D-Ile-Leu-D-Trp) (“JKC 301”); cyclo(D-Ser-Pro-D-Val-Leu-D-Trp) (“JK 302”); 5-(dimethylamino)-N-(3,4-dimethyl-5-isoxazolyl)-1-naphthalenesulphonamide (“BMS 182874”); and N-[1-Formyl-N-[N-[(hexahydro-1H-azepin-1-yl)carbonyl]-L-leucyl]-D-tryptophyl]-D-tryptophan (“BQ 610”). Concentrations for a representative three of these agents is set forth in Table 19.

Table 19

10 Therapeutic and Preferred Concentrations of
Spasm Inhibitory Agents

<u>Class of Agent</u>	<u>Therapeutic Concentrations (Nanomolar)</u>	<u>Preferred Concentrations (Nanomolar)</u>
<u>Endothelin Receptor Antagonists:</u>		
BQ 123	0.01-1,000	10-1,000
FR 139317	1-100,000	100-10,000
BQ 610	0.01 to 10,000	10 - 1,000

4. Ca²⁺ Channel Antagonists

15 Calcium channel antagonists are a distinct group of drugs that interfere with the transmembrane flux of calcium ions required for activation of cellular responses mediating neuroinflammation. Calcium entry into platelets and white blood cells is a key event mediating activation of responses in these cells. Furthermore, the role of bradykinin receptors and neurokinin receptors (NK₁ and NK₂) in mediating the neuroinflammation signal transduction pathway includes increases in intracellular
20 calcium, thus leading to activation of calcium channels on the plasma membrane. In many tissues, calcium channel antagonists, such as nifedipine, can reduce the release of arachidonic acid, prostaglandins, and leukotrienes that are evoked by various stimuli. Moncada, S., Flower, R. and Vane, J. in *Goodman's and Gilman's Pharmacological Basis of Therapeutics*, (7th ed.), MacMillan Publ. Inc., pp. 660-5
25 (1995).

Calcium channel antagonists also interfere with the transmembrane flux of calcium ions required by vascular smooth muscle for contractions. This effect provides the rationale for the use of calcium channel antagonists perioperatively during procedures in which the goal is to alleviate vasospasm and promote relaxation of smooth muscle. The dihydropyridines, including nisoldipine, act as specific inhibitors (antagonists) of the voltage-dependent gating of the L-type subtype of calcium channels. Systemic administration of the calcium channel antagonist nifedipine during cardiac surgery previously has been utilized to prevent or minimize coronary artery vasospasm. Seitelberger, R., et. al., *Circulation*, Vol. 83, pp. 460-468 (1991).

Calcium channel antagonists, which are among the anti-spasm agents useful in the present invention, exhibit synergistic effect when combined with other agents of the present invention. Calcium (Ca^{2+}) channel antagonists and nitric oxide (NO) donors interact in achieving vasorelaxation or smooth muscle relaxation, i.e., in inhibiting spasm activity. A rationale for dual use is based upon the fact that these two classes of drugs have different molecular mechanisms of action, may not be completely effective in achieving relaxation used alone, and may have different time periods of effectiveness. In fact, there are numerous studies showing that calcium channel antagonists alone cannot achieve complete relaxation of vascular muscle that has been precontracted with a receptor agonist.

The effect of nisoldipine, used alone and in combination with nitroglycerin, on spasm of the internal mammary artery (IMA) showed that the combination of the two drugs produced a large positive synergistic effect in the prevention of contraction (Liu et al., 1994). These studies provide a scientific basis for combination of a calcium channel antagonist and nitric oxide (NO) donor for the efficacious prevention of vasospasm and relaxation of smooth muscle. Examples of systemic administration of nitroglycerin and nifedipine during cardiac surgery to prevent and treat myocardial ischemia or coronary artery vasospasm have been reported (Cohen et al., 1983; Seitelberger et al., 1991).

Calcium channel antagonists also exhibit synergistic effect with endothelin receptor subtype A (ET_A) antagonists. Yanagisawa and coworkers observed that dihydropyridine antagonists blocked effects of ET-1, an endogenous agonist at the ET_A receptor in coronary arterial smooth muscle, and hence speculated that ET-1 is an endogenous agonist of voltage-sensitive calcium channels. It has been found that the sustained phase of intracellular calcium elevation in smooth muscle cells induced by ET_A receptor activation requires extracellular calcium and is at least partially

blocked by nicardipine. Thus, the inclusion of a calcium channel antagonist would be expected to synergistically enhance the actions of an ET_A antagonist when combined in a surgical solution.

Calcium channel antagonists and ATP-sensitive potassium channel openers
5 likewise exhibit synergistic action. Potassium channels that are ATP-sensitive (K_{ATP}) couple the membrane potential of a cell to the cell's metabolic state via sensitivity to adenosine nucleotides. K_{ATP} channels are inhibited by intracellular ATP but are stimulated by intracellular nucleotide diphosphates. The activity of these channels is controlled by the electrochemical driving force to potassium and
10 intracellular signals (e.g., ATP or a G-protein), but are not gated by the membrane potential per se. K_{ATP} channels hyperpolarize the membrane and thus allow them to control the resting potential of the cell. ATP-sensitive potassium currents have been discovered in skeletal muscle, brain, and vascular and nonvascular smooth muscle. Binding studies with radiolabeled ligands have confirmed the existence of ATP-
15 sensitive potassium channels which are the receptor targets for the potassium-channel opener drugs such as pinacidil. Opening of these channels causes potassium efflux and hyperpolarizes the cell membrane. This hyperpolarization (1) induces a reduction in intracellular free calcium through inhibition of voltage-dependent Ca^{2+} channels by reducing the probability of opening L-type or T-type calcium channels,
20 (2) restrains agonist induced (at receptor operated channels) Ca^{2+} release from intracellular sources through inhibition of inositol triphosphate (IP_3) formation, and (3) lowers the efficiency of calcium as an activator of contractile proteins. The combined actions of these two classes of drugs (ATP-sensitive potassium channel openers and calcium channel antagonists) will clamp the target cells into a relaxed
25 state or one which is more resistant to activation.

Finally, calcium channel antagonists and tachykinin and bradykinin antagonists exhibit synergistic effects in mediating neuroinflammation. The role of neurokinin receptors in mediating neuroinflammation has been established. The neurokinin₁ (NK_1) and neurokinin₂ (NK_2) receptor (members of the G-protein
30 coupled superfamily) signal transduction pathway includes increases in intracellular calcium, thus leading to activation of calcium channels on the plasma membrane. Similarly, activation of bradykinin₂ (BK_2) receptors is coupled to increases in intracellular calcium. Thus, calcium channel antagonists interfere with a common mechanism involving elevation of intracellular calcium, part of which enters through
35 L-type channels. This is the basis for synergistic interaction between calcium channel antagonists and antagonists to neurokinin and bradykinin₂ receptors.

Suitable calcium channel antagonists for the practice of the present invention include nisoldipine, nifedipine, nimodipine, lacidipine, isradipine and amlodipine. Suitable concentrations for these agents are set forth in Table 20.

Table 20

5 Therapeutic and Preferred Concentrations of
Spasm Inhibitory Agents

<u>Class of Agent</u>	<u>Therapeutic Concentrations (Nanomolar)</u>	<u>Preferred Concentrations (Nanomolar)</u>
<u>Calcium Channel Antagonists:</u>		
nisoldipine	1-10,000	100-1,000
nifedipine	1-10,000	100-5,000
nimodipine	1-10,000	100-5,000
lacidipine	1-10,000	100-5,000
isradipine	1-10,000	100-5,000
amlodipine	1-10,000	100-5,000

J. Anti-Restenosis Agents

10 Solutions of the present invention utilized for cardiovascular and general vascular procedures may optionally also include an anti-restenosis agent, particularly for angioplasty, rotational atherectomy and other interventional vascular uses. The following drugs are suitable for inclusion in the previously described cardiovascular and general vascular irrigation solutions when limitation of restenosis is indicated. The following anti-restenosis agents would preferably be combined with anti-spasm, 15 and still more preferably also with anti-pain/anti-inflammation agents in the solutions of the present invention.

1. Antiplatelet Agents

At sites of arterial injury, platelets adhere to collagen and fibrinogen via specific cell surface receptors, and are then activated by several independent

mediators. A variety of agonists are able to activate platelets, including collagen, ADP, thromboxane A₂, epinephrine and thrombin. Collagen and thrombin serve as primary activators at sites of vascular injury, while ADP and thromboxane A₂ act to recruit additional platelets into a growing platelet plug. The activated platelets degranulate and release other agents which serve as chemoattractants and vasoconstrictors, thus promoting vasospasm and platelet accumulation. Thus, anti-platelet agents can be antagonists drawn from any of the above agonist-receptor targets.

Since platelets play such an important role in the coagulation cascade, oral antiplatelet agents have been routinely administered to patients undergoing vascular procedures. Indeed, because of this multiplicity of activators and observations that single antiplatelet agents are not effective, some investigators have concluded that a combined treatment protocol is necessary for effectiveness. Recently, Willerson and coworkers reported the intravenous use of 3 combined agents, ridogrel (an antagonist of thromboxane A₂), ketanserine (a serotonin antagonist) and clopidogrel (an ADP antagonist). They found that the combination of 3 antagonists inhibited several relevant platelet functions and reduced neointimal proliferation in a canine coronary angioplasty model (JACC Abstracts, Feb. 1995). It is still uncertain which approach to treatment of coronary thrombosis will be most successful. One possibility would be to include an antiplatelet agent and an antithrombotic agent in the cardiovascular and general vascular solutions of the present invention.

a. Thrombin Inhibitors and Receptor Antagonists

Thrombin plays a central role in vascular lesion formation and is considered the principal mediator of thrombogenesis. Thus, thrombus formation at vascular lesion sites during and after PTCA (percutaneous transluminal coronary angioplasty) or other vascular procedure is central to acute reocclusion and chronic restenosis. This process can be interrupted by application of direct anti-thrombins, including hirudin and its synthetic peptide analogs, as well as thrombin receptor antagonist peptides (Harker, et al., 1995, Am. J. Cardiol 75, 12B). Thrombin is also a potent growth factor which initiates smooth muscle cell proliferation at sites of vascular injury. In addition, thrombin also plays a role in modulating the effects of other growth factors such as PDGF (platelet-derived growth factor), and it has been shown that thrombin inhibitors reduce expression of PDGF mRNA subsequent to vascular injury induced by balloon angioplasty.

Hirudin is the prototypic direct antithrombin drug since it binds to the catalytic site and the substrate recognition site (exosite) of thrombin. Animal studies using baboons have shown that this proliferative response can be reduced 80% using recombinant hirudin (Ciba-Geigy). Hirulog (Biogen) is a dodecapeptide modeled after hirudin, and binds to the active site of thrombin via a Phe-Pro-Arg linker molecule. Large clinical trials of hirudin and hirulog are underway to test their efficacy in reducing vascular lesions after PTCA and Phase II data on these inhibitors to date is positive, and both drugs are believed to be suitable in the solutions of the present invention. Preliminary results of a 1,200 patient trial with repeat angiographic assessment at 6 months to detect restenosis indicated superior short-term suppression of ischemic events with hirudin vs. heparin. An advantage of this approach is that no significant bleeding complications were reported. A sustained-release local hirulog therapy was found to decrease early thrombosis but not neointimal thickening after arterial stenting in pigs. Muller, D. et al., *Sustained-Release Local Hirulog Therapy Decreases Early Thrombosis but not Neointimal Thickening After Arterial Stenting*, Am. Heart J. 133, No. 2, pp. 211-218, (1996). In this study, hirulog was released from an impregnated polymer placed around the artery.

Other active anti-thrombin agents being tested which are theorized to be suitable for the present invention are argatroban (Texas Biotechnology) and efegatran (Lilly).

Table 21
Therapeutic and Preferred Concentrations of
Restenosis Inhibitory Agents

<u>Class of Agent</u>	<u>Therapeutic/Preferred Concentrations</u> <u>(Nanomolar)</u>	<u>More preferred</u> <u>(Nanomolar)</u>
<u>Thrombin Inhibitors</u>		
<u>and Receptor Antagonists:</u>		
hirudin	0.00003-3/0.0003-0.3	0.03
hirulog	0.2-20,000/2-2,000	200

b. ADP Receptor Antagonists (Purinoceptor Antagonists)

5 Ticlopidine, an analog of ADP, inhibits both thromboxane and ADP-induced
platelet aggregation. It is likely that ticlopidine blocks interaction of ADP with its
receptor, thereby inhibiting signal transduction by this G-protein coupled receptor on
the surface of platelet membranes. A preliminary study showed it to be more
effective than aspirin in combination with dipyridamole. However, the clinical use
10 of ticlopidine has been limited because it causes neutropenia. Clopidogrel, a
ticlopidine analog, is thought to have fewer adverse side effects than ticlopidine and
is currently being studied for prevention of ischemic events. It is theorized that these
agents may be suitable for use in the solutions of the present invention.

c. Thromboxane Inhibitors and Receptor Antagonists

15 Agents currently utilized for conventional methods of treatment of
thrombosis rely upon aspirin, heparin and plasminogen activators. Aspirin
irreversibly acetylates cyclooxygenase and inhibits the synthesis of thromboxane A2
and prostacyclin. While data support a benefit of aspirin for PTCA, the underlying
efficacy of aspirin is considered as only partial or modest. This is likely due to
20 platelet activation through thromboxane A2 independent pathways that are not
blocked by aspirin induced acetylation of cyclooxygenase. Platelet aggregation and
thrombosis may occur despite aspirin treatment. Aspirin in combination with
dipyridamole has also been shown to reduce the incidence of acute complication
during PTCA but not the incidence of restenosis.

Two thromboxane receptor antagonists appear to be more efficacious than aspirin and are believed suitable for use in the solutions and methods of the present invention. Ticlopidine inhibits both thromboxane and ADP-induced platelet aggregation. Ridogrel (R68060) is a combined thromboxane B2 synthetase inhibitor and thromboxane-prostaglandin endoperoxide receptor blocker. It has been compared with salicylate therapy in an open-pilot study of patients undergoing PTCA administered in combination with heparin. Timmermans, C., et al., *Ridogrel in the Setting of Percutaneous Transluminal Coronary Angioplasty*, Am. J. Cardiol. 68, pp. 463-466, (1991). Treatment consisted of administering a slow intravenous injection of 300 mg just prior to the start of the PTCA procedure and continued orally after 12 hrs with a dose of 300 mg/twice daily. From this study, ridogrel was found to be primarily successful since no early acute reocclusion occurred in 30 patients. Bleeding complications did occur in a significant number (34%) of patients, and this appears to be a complicating factor that would require special care. The study confirmed that ridogrel is a potent long-lasting inhibitor of thromboxane B2 synthetase.

2. Inhibitors of Cell Adhesion Molecules

a. Selectin Inhibitors

Selectin inhibitors block the interaction of a selectin with its cognate ligand or receptor. Representative examples of selectin targets at which these inhibitors would act include, but are not limited to, E-selectin and P-selectin receptors. Upjohn Co. has licensed rights to a monoclonal antibody developed by Cytel Corps that inhibits the activity of P-selectin. The product, CY 1748, is in preclinical development, with a potential indication being restenosis.

b. Integrin inhibitors

The platelet glycoprotein IIb/IIIa complex is present on the surface of resting as well as activated platelets. It appears to undergo a transformation during platelet activation which enables it to serve as a binding site for fibrinogen and other adhesive proteins. Most promising new antiplatelet agents are directed at this integrin cell surface receptor which represents a final common pathway for platelet aggregation.

Several types of agents fit into the class of GPIIb/IIIa integrin antagonists. A monoclonal antibody, c7E3, (CentoRx; Centocor, Malvern PA) has been intensively studied to date in a 3,000 patient PTCA study. It is a chimeric human/murine hybrid.

A 0.25 mg/kg bolus of c7E3 followed by 10 µg/min intravenous infusion for 12 hrs produced greater than 80% blockade of GPIIb/IIIa receptors for the duration of the infusion. This was correlated with a greater than 80% inhibition of platelet aggregation. The antibody was coadministered with heparin and an increased risk of bleeding was noted. Additional information was obtained from the EPIC trial which showed a significant reduction in the primary end point, a composite of death rate, incidence of nonfatal myocardial infarction and need for coronary revascularization, and suggested a long term benefit. Tcheng, (1995) Am. Heart J. 130, 673-679. A phase IV study (EPILOG) designed to address safety and efficacy issues with c7E3 Fab is planned or in progress. This monoclonal antibody can also be classified as a platelet membrane glycoprotein receptor antagonist directed against the glycoprotein IIb/IIIa receptor.

The platelet glycoprotein IIb/IIIa receptor blocker, integrilin, is a cyclic heptapeptide that is highly specific for this molecular target. In contrast to the antibody, it has a short biologic half-life (about 10 minutes). The safety and efficacy of integrilin was first evaluated in the Phase II Impact trial. Either 4 or 12 hour intravenous infusions of 1.0 µg/kg/min of integrilin were utilized (Topol, E., 1995 Am. J. Cardiol, 27B-33B). It was provided in combination with other agents (heparin, aspirin) and was shown to exhibit potent anti-platelet aggregation properties (>80%). A phase III study, the IMPACT II trial, of 4000 patients showed that integrilin markedly reduced ischemic events in patients who had undergone Rotablator atherectomy (JACC Abstracts, 1996). Suitable concentrations of the drugs c7E3 and integrilin for use in the present invention are set forth below.

In addition, two peptidomimetics, MK-383 (Merck) and RO 4483 (Hoffmann-LaRoche), have been studied in Phase II clinicals. Since these are both small molecules, they have a short half-life and high potency. However, these seem to also have less specificity, interacting with other closely related integrins. It is theorized that these peptidomimetics may also be suitable for use in the present invention.

Table 22

Therapeutic and Preferred Concentrations of
Restenosis Inhibitory Agents

<u>Class of Agent</u>	<u>Therapeutic/Preferred Concentrations</u> <u>(Nanomolar)</u>	<u>More preferred</u> <u>(Nanomolar)</u>
<u>Cell Adhesion Inhibitors:</u>		
c7E3	0.5-50,000/5-5,000	500
Integrelin	0.1-10,000/1-1000 x K _d	100 x K _d

5

3. Anti-chemotactic agents

Anti-chemotactic agents prevent the chemotaxis of inflammatory cells. Representative examples of anti-chemotactic targets at which these agents would act include, but are not limited to, F-Met-Leu-Phe receptors, IL-8 receptors, MCP-1 receptors, and MIP-1- α /RANTES receptors. Drugs within this class of agents are early in the development stage, but it is theorized that they may be suitable for use in the present invention.

10

4. Interleukin Receptor Antagonists

Interleukin receptor antagonists are agents which block the interaction of an interleukin with its cognate ligand or receptor. Specific receptor antagonists for any of the numerous interleukin receptors are early in the development process. The exception to this is the naturally occurring existence of a secreted form of the IL-1 receptor, referred to as IL-1 antagonist protein (IL-1AP). This antagonist binds IL-1 and has been shown to suppress the biological actions of IL-1, and is theorized to be suitable for the practice of the present invention.

15

20

5. Intracellular Signaling Inhibitors

a. Protein Kinase Inhibitors

i. Protein Kinase C (PKC) Inhibitors

Protein kinase C (PKC) plays a crucial role in cell-surface signal transduction for a number of physiological processes. PKC isozymes can be activated as

downstream targets resulting from initial activation of either G-protein coupled receptors (e.g., serotonin, endothelin, etc.) or growth-factor receptors such as PDGF. Both of these receptor classes play important roles in mediating vascular spasm and restenosis subsequent to coronary balloon angioplasty procedures.

5 Molecular cloning analysis has revealed that PKC exists as a large family consisting of at least 8 subspecies (isozymes). These isozymes differ substantially in structure and mechanism for linking receptor activation to changes in the proliferative response of specific cells. Expression of specific isozymes is found in a wide variety of cell types, including: platelets, neutrophils, myeloid cells, and
10 smooth muscle cells. Inhibitors of PKC are therefore likely to effect signaling pathways in several cell types unless the inhibitor shows isozyme specificity. Thus, inhibitors of PKC can be predicted to be effective in blocking the proliferative response of smooth muscle cells and may also have an anti-inflammatory effect in blocking neutrophil activation and subsequent attachment. Several inhibitors have
15 been described and initial reports indicate an IC_{50} of 50 μ M for calphostin C inhibitory activity. G-6203 (also known as Go 6976) is a new, potent PKC inhibitor with high selectivity for certain PKC isotypes with IC_{50} values in the 2-10 μ M range. Concentrations of these and another drug, GF 109203X, also known as Go 6850 or bisindoylmaleimide I (available from Warner-Lambert), that are believed to be
20 suitable for use in the present invention are set forth below.

Table 23

Therapeutic and Preferred Concentrations of
Restenosis Inhibitory Agents

<u>Class of Agent</u>	<u>Therapeutic/Preferred Concentrations</u> <u>(Nanomolar)</u>	<u>More preferred</u> <u>(Nanomolar)</u>
<u>Protein Kinase C Inhibitors:</u>		
calphostin C	0.5-50,000/100-5,000	500
GF 109203X	0.1-10,000/1-1,000	100
G-6203 (Go 6976)	0.1-10,000/1-1,000	100

ii. Protein tyrosine kinase inhibitors

5 Although there is a tremendous diversity among the numerous members of
the receptors tyrosine-kinase (RTK) family, the signaling mechanisms used by these
receptors share many common features. Biochemical and molecular genetic studies
have shown that binding of the ligand to the extracellular domain of the RTK rapidly
10 activates the intrinsic tyrosine kinase catalytic activity of the intracellular domain
(see FIGURE 5). The increased activity results in tyrosine-specific phosphorylation
of a number of intracellular substrates which contain a common sequence motif.
Consequently, this causes activation of numerous "downstream" signaling molecules
and a cascade of intracellular pathways that regulate phospholipid metabolism,
15 arachidonate metabolism, protein phosphorylation (involving mechanisms other than
protein kinases), calcium mobilization and transcriptional activation (see FIGURE 2).
Growth-factor-dependent tyrosine kinase activity of the RTK cytoplasmic domain is
the primary mechanism for generation of intracellular signals that lead to cellular
proliferation. Thus, inhibitors have the potential to block this signaling and thereby
20 prevent the proliferative response (see FIGURE 5).

20 The platelet-derived growth factor (PDGF) receptor is of great interest as a
target for inhibition in the cardiovascular field since it is believed to play a
significant role both in atherosclerosis and restenosis. The release of PDGF by
platelets at damaged surfaces of endothelium within blood vessels results in
stimulation of PDGF receptors on vascular smooth muscle cells. As described
25 above, this initiates a sequence of intracellular events leading to enhanced

proliferation and neointimal thickening. An inhibitor of PDGF kinase activity would be expected to prevent proliferation and enhance the probability of success following cardiovascular and general vascular procedures. Any of several related tyrphostin compounds have potential as specific inhibitors of PDGF-receptor tyrosine kinase activity (IC₅₀s *in vitro* in the 0.5-1.0 μM range), since they have little effect on other protein kinases and other signal transduction systems. To date, only a few of the many tyrphostin compounds are commercially available, and suitable concentrations for these agents as used in the present invention are set forth below. In addition, staurosporine has been reported to demonstrate potent inhibitory effects against several protein tyrosine kinases of the src subfamily and a suitable concentration for this agent as used in the present invention also is set forth below.

Table 24

Therapeutic and Preferred Concentrations of
Restenosis Inhibitory Agents

15

<u>Class of Agent</u>	<u>Therapeutic/Preferred Concentrations</u> <u>(Nanomolar)</u>	<u>More preferred</u> <u>(Nanomolar)</u>
<u>Protein Kinase Inhibitors</u>		
lavendustin A	10-100,000/100-10,000	10,000
tyrphostin AG1296	10-100,000/100-20,000	10,000
tyrphostin AG1295	10-100,000/100-20,000	10,000
staurosporine	1-100,000/10-10,000	1,000

b. Modulators of Intracellular Protein Tyrosine Phosphatases.

Non-transmembrane protein tyrosine phosphatases (PTPases) containing src-homology₂ SH2 domains are known and nomenclature refers to them as SH-PTP1 and SH-PTP2. In addition, SH-PTP1 is also known as PTP1C, HCP or SHP. SH-PTP2 is also known as PTP1D or PTP2C. Similarly, SH-PTP1 is expressed at high levels in hematopoietic cells of all lineages and all stages of

20

differentiation, and the SH-PTP1 gene has been identified as responsible for the motheaten (me) mouse phenotype and this provides a basis for predicting the effects of inhibitors that would block its interaction with its cellular substrates. Stimulation of neutrophils with chemotactic peptides is known to result in the activation of tyrosine kinases that mediate neutrophil responses (Cui, et al., 1994 J. Immunol.) and PTPase activity modulates agonist induced activity by reversing the effects of tyrosine kinases activated in the initial phases of cell stimulation. Agents that could stimulate PTPase activity could have potential therapeutic applications as anti-inflammatory mediators.

10 These same PTPases have also been shown to modulate the activity of certain RTKs. They appear to counter-balance the effect of activated receptor kinases and thus may represent important drug targets. *In vitro* experiments show that injection of PTPase blocks insulin stimulated phosphorylation of tyrosyl residues on endogenous proteins. Thus, activators of PTPase activity could serve to reverse
15 activation of PDGF-receptor action in restenosis, and are believed to be useful in the solutions of the present invention. In addition, receptor-linked PTPases also function as extracellular ligands, similar to those of cell adhesion molecules. The functional consequences of the binding of a ligand to the extracellular domain have not yet been defined but it is reasonable to assume that binding would serve to modulate
20 phosphatase activity within cells (Fashena and Zinn, 1995, Current Biology, 5, 1367-1369) . Such actions could block adhesion mediated by other cell surface adhesion molecules (NCAM) and provide an anti-inflammatory effect. No drugs have been developed yet for these applications.

c. Inhibitors of SH2 Domains (src Homology₂ Domains).

25 SH2 domains, originally identified in the src subfamily of protein tyrosine kinases (PTKs), are noncatalytic protein sequences and consist of about 100 amino acids conserved among a variety of signal transducing proteins (Cohen, et al., 1995). SH2 domains function as phosphotyrosine-binding modules and thereby mediate critical protein-protein associations in signal transduction pathways within cells
30 (Pawson, Nature, 573-580, 1995). In particular, the role of SH2 domains has been clearly defined as critical for receptor tyrosine kinase (RTK) mediated signaling such as in the case of the platelet-derived growth factor (PDGF) receptor. Phosphotyrosine-containing sites on autophosphorylated RTKs serve as binding sites for SH2-proteins and thereby mediate the activation of biochemical signaling

pathways (see FIGURE 2) (Carpenter, G., FASEB J. 6:3283-3289, 1992; Sierke, S. and Koland, J. Biochem. 32:10102-10108, 1993). The SH2 domains are responsible for coupling the activated growth-factor receptors to cellular responses which include alterations in gene expression, and ultimately cellular proliferation (see FIGURE 5).
5 Thus, inhibitors that will selectively block the effects of activation of specific RTKs expressed on the surface of vascular smooth muscle cells are predicted to be effective in blocking proliferation and the restenosis process after PTCA or other vascular procedure. One RTK target of current interest is the PDGF receptor.

At least 20 cytosolic proteins have been identified that contain SH2 domains and function in intracellular signaling. The distribution of SH2 domains is not
10 restricted to a particular protein family, but found in several classes of proteins, protein kinases, lipid kinases, protein phosphatases, phospholipases, Ras-controlling proteins and some transcription factors. Many of the SH2-containing proteins have known enzymatic activities while others (Grb2 and Crk) function as "linkers" and
15 "adapters" between cell surface receptors and "downstream" effector molecules (Marengere, L., et al., Nature 369:502-505, 1994). Examples of proteins containing SH2 domains with enzymatic activities that are activated in signal transduction include, but are not limited to, the src subfamily of protein tyrosine kinases (src (pp60^{c-src}), abl, lck, fyn, fgr and others), phospholipase C γ (PLC γ),
20 phosphatidylinositol 3-kinase (PI-3-kinase), p21-ras GTPase activating protein (GAP) and SH2 containing protein tyrosine phosphatases (SH-PTPases) (Songyang, et al., Cell 72, 767-778, 1993). Due to the central role these various SH2-proteins occupy in transmitting signals from activated cell surface receptors into a cascade of additional molecular interactions that ultimately define cellular responses, inhibitors
25 which block specific SH2 protein binding are desirable as agents for a variety of potential therapeutic applications.

In addition, the regulation of many immune/inflammatory responses is mediated through receptors that transmit signals through non-receptor tyrosine kinases containing SH2 domains. T-cell activation via the antigen specific T-cell
30 receptor (TCR) initiates a signal transduction cascade leading to lymphokine secretion and T-cell proliferation. One of the earliest biochemical responses following TCR activation is an increase in tyrosine kinase activity. In particular, neutrophil activation is in part controlled through responses of the cell surface immunoglobulin G receptors. Activation of these receptors mediates activation of
35 unidentified tyrosine kinases which are known to possess SH2 domains. Additional evidence indicates that several src-family kinases (lck, blk, fyn) participate in signal

transduction pathways leading from cytokine and integrin receptors and hence may serve to integrate stimuli received from several independent receptor structures. Thus, inhibitors of specific SH2 domains have the potential to block many neutrophil functions and serve as anti-inflammatory mediators.

5 Efforts to develop drugs targeted to SH2 domains currently are being conducted at the biochemical *in vitro* and cellular level. Should such efforts be successful, it is theorized that the resulting drugs would be useful in the practice of the present invention.

d. Calcium Channel Antagonists

10 Calcium channel antagonists, previously described with relation to spasm inhibitory function, also can be used as anti-restenotic agents in the cardiovascular and general vascular solutions of the present invention. Activation of growth factor receptors, such as PDGF, is known to result in an increase in intracellular calcium (see FIGURE 2). Studies at the cellular level have shown that actions of calcium
15 channel antagonists are effective at inhibiting mitogenesis of vascular smooth muscle cells.

6. Synergistic Interactions Derived From Therapeutic Combinations Of Anti-Restenosis Agents And Other Agents Used In Cardiovascular and General Vascular Solutions

20 Given the complexity of the disease process associated with restenosis after PTCA or other cardiovascular or general vascular therapeutic procedure and the multiplicity of molecular targets involved, blockade or inhibition of a single molecular target is unlikely to provide adequate efficacy in preventing vasospasm and restenosis (see FIGURE 2). Indeed, a number of animal studies targeting
25 different individual molecular receptors and or enzymes have not proven effective in animal models or have not yielded efficacy for both pathologies in clinical trials to date. (Freed, M., et al., *An Intensive Poly-pharmaceutical Approach to the Prevention of Restenosis: the Mevacor, Ace Inhibitor, Colchicine (BIG-MAC) Pilot Trial*, J. Am. Coll. of Cardiol. 21, p. 33A, (1993). Serruys, P., et al., *PARK: the Post
30 Angioplasty Restenosis Ketanserin Trial*, J. Am. Coll. of Cardiol. 21, p. 322A, (1993). Therefore, a therapeutic combination of drugs acting on distinct molecular targets and delivered locally appears necessary for clinical effectiveness in the therapeutic approach to vasospasm and restenosis. As described below, the rationale for this synergistic molecular targeted therapy is derived from recent advances in

understanding fundamental biochemical mechanisms by which vascular smooth muscle cells in the vessel wall transmit and integrate stimuli to which they are exposed during PTCA or other vascular interventional procedure.

a. "Crosstalk" and Convergence in Major Signaling Pathways

5 The molecular switches responsible for cell signaling have been traditionally divided into two major discrete signaling pathways, each comprising a distinct set of protein families that act as transducers for a particular set of extracellular stimuli and mediating distinct cell responses. One such pathway transduces signals from neurotransmitters and hormones through G-protein coupled receptors (GPCRs) to
10 produce contractile responses using intracellular targets of trimeric G proteins and Ca^{2+} (see FIGURE 2). These stimuli and their respective receptors mediate smooth muscle contraction and may induce vasospasm in the context of PTCA or other cardiovascular or general vascular therapeutic or diagnostic procedure. Examples of signaling molecules involved in mediating spasm through the GPCR pathway are
15 5-HT and endothelin for which antagonists have been included acting via their respective G-protein coupled receptors.

A second major pathway transduces signals from growth factors, such as PDGF, through tyrosine kinases, adaptor proteins and the Ras protein into regulation of cell proliferation and differentiation (see FIGURES 2 and 5). This pathway may
20 also be activated during PTCA or other cardiovascular or general vascular procedure leading to a high incidence of vascular smooth muscle cell proliferation. An example of a restenosis drug target is the PDGF-receptor.

Signals transmitted from neurotransmitters and hormones stimulate either of two classes of receptors: G-protein-coupled receptors, composed of seven-helix
25 transmembrane regions, or ligand-gated ion channels. "Downstream" signals from both kinds of receptors converge on controlling the concentration of cytoplasmic Ca^{2+} which triggers contraction in smooth muscle cells (see FIGURE 2). Each GPCR transmembrane receptor activates a specific class of trimeric G proteins, including G_q , G_i or many others. G_α and/or $G_{\beta\gamma}$ subunits activate phospholipase C_β ,
30 resulting in activation of protein kinase C (PKC) and an increase in the levels of cytoplasmic calcium by release of calcium from intracellular stores.

Growth factor signaling, such as mediated by PDGF, converges on regulation of cell growth. This pathway depends upon phosphorylation of tyrosine residues in receptor tyrosine kinases and "downstream" enzymes (phospholipase C_γ , discussed

above with regard to tyrosine kinases). Activation of the PDGF-receptor also leads to stimulation of PKC and elevation of intracellular calcium, common steps shared by the GPCRs (see FIGURE 2). It is now recognized that ligand-independent "crosstalk" can transactivate tyrosine kinase receptor pathways in response to stimulation of GPCRs. Recent work has identified Shc, an adaptor protein in the tyrosine kinase/Ras pathway, as a key intermediary protein that relays messages from the GPCR pathway described above to the tyrosine kinase pathway (see FIGURE 2) (Lev et al., 1995, Nature 376:737). Activation of Shc is calcium dependent. Thus, a combination of selective inhibitors which blocks transactivation of a common signaling pathway leading to vascular smooth muscle cell proliferation will act synergistically to prevent spasm and restenosis after PTCA or other cardiovascular or general vascular procedure. Specific examples are briefly detailed below.

b. Synergistic Interactions between PKC Inhibitors and Calcium Channel Antagonists

In this case synergistic interactions among PKC inhibitors and calcium channel antagonists in achieving vasorelaxation and inhibition of proliferation occur due to "crosstalk" between GPCR and tyrosine kinase signaling pathways (see FIGURE 2). A rationale for dual use is based upon the fact that these drugs have different molecular mechanisms of action. As described above, GPCR stimulation results in activation of protein kinase C and an increase in the levels of cytoplasmic calcium by release of calcium from intracellular stores. Calcium-activated PKC is a central control point in the transmission of extracellular responses. "Crosstalk" from GPCR stimulated pathways through PKC can lead to mitogenesis of vascular smooth muscle cells and thus calcium channel antagonists will have the dual action of directly blocking spasm and further preventing activation of proliferation by inhibiting Shc activation. Conversely, the PKC inhibitor acts on part of the pathway leading to contraction.

c. Synergistic Effects of PKC Inhibitors, 5-HT₂ Antagonists and ET_A Antagonists

The 5-HT₂ receptor family contains three members designated 5-HT_{2A}, 5-HT_{2B}, and 5-HT_{2C}, all of which share the common property of being coupled to phosphatidylinositol turnover and increases in intracellular calcium (Hoyer et al., 1988, Hartig et al., 1989). The distribution of these receptors includes vascular

smooth muscle and platelets and, due to their localization, these 5-HT receptors are important in mediating spasm, thrombosis and restenosis. It has been found that the sustained phase of intracellular calcium elevation in smooth muscle cells induced by ET_A receptor activation requires extracellular calcium and is at least partially blocked by nicardipine. Since activation of both 5-HT₂ receptors and ET_A receptors is mediated through calcium, the inclusion of a PKC inhibitor is expected to synergistically enhance the actions of antagonists to both of these receptors when combined in a surgical solution (see FIGURES 2 and 4).

**d. Synergistic Effects of Protein Tyrosine Kinase Inhibitors
and Calcium Channel Antagonists**

The mitogenic effect of PDGF (or basic fibroblast growth factor or insulin-like-growth-factor-1) is mediated through receptors that possess intrinsic protein tyrosine kinase activity. The substrates for PDGF phosphorylation are many and lead to activation of mitogen-activated protein kinases (MAPK) and ultimately proliferation (see FIGURE 5). The endothelin, 5-HT and thrombin receptors, which are members of the G-protein coupled superfamily, trigger a signal transduction pathway which includes increases in intracellular calcium, leading to activation of calcium channels on the plasma membrane. Thus, calcium channel antagonists interfere with a common mechanism employed by these GPCRs. It has recently been shown that activation of certain GPCRs, including endothelin and bradykinin, leads to a rapid increase in tyrosine phosphorylation of a number of intracellular proteins. Some of the proteins phosphorylated parallel those known necessary for mitogenic stimulation. The rapidity of the process was such that changes were detectable in seconds and the targets acted upon likely play a role in mitogenesis. These tyrosine phosphorylation events were not blocked by a selective PKC inhibitor or apparently mediated by increased intracellular calcium. Thus, since two independent pathways, the GPCR and tyrosine phosphorylation pathways, can drive the vascular smooth muscle cells into a proliferative state, it is necessary to block both independent signaling arms. This is the basis for the synergistic interaction between calcium channel antagonists and tyrosine kinase inhibitors in the surgical solution. Because the actions of the protein tyrosine kinase inhibitors in preventing vascular smooth muscle cell proliferation occur via independent molecular pathways (described above) from those involving calcium and protein kinase C, the combination of the two classes of drugs, calcium channel antagonists and protein tyrosine kinase

inhibitors, is expected to be more efficacious in inhibiting spasm and restenosis than employing either single class of drug alone.

**e. Synergistic Effects of Protein Tyrosine Kinase Inhibitors
and Thrombin Receptor Antagonists**

5 Thrombin mediates its action via the thrombin receptor, another member of
the GPCR superfamily. Binding to the receptor stimulates platelet aggregation,
smooth muscle cell contraction and mitogenesis. Signal transduction occurs through
multiple pathways: activation of phospholipase (PLC) through G proteins and
activation of tyrosine kinases. The activation of tyrosine kinase activity is also
10 essential for mitogenesis of the vascular smooth muscle cells. Experiments have
shown that inhibition with a specific tyrosine kinase inhibitor was effective in
blocking thrombin-induced mitosis, although there were no effects on the PLC
pathway as monitored by measurement of intracellular calcium (Weiss and Nucitelli,
1992, J. Biol. Chem. 267:5608-5613). Because the actions of the protein tyrosine
15 kinase inhibitors in preventing vascular smooth muscle cell proliferation occur via
independent molecular pathways (described above) from those involving calcium and
protein kinase C, the combination of protein tyrosine kinase inhibitors and thrombin
receptor antagonists is anticipated to be more efficacious in inhibiting platelet
aggregation, spasm and restenosis than employing either class of agent alone.

20 7. Cyclooxygenase-2 (COX-2) Inhibitors

Nonsteroidal anti-inflammatory drugs (NSAIDs) are widely used as anti-
inflammatory, anti-pyretic, anti-thrombotic and analgesic agents (Lewis, R.A.,
Prostaglandins and Leukotrienes, In: Textbook of Rheumatology, 3d ed. (Kelley
W., et. al., eds.), p. 258 (1989). The molecular target for these drugs is the first
25 enzyme in the prostaglandin synthetic pathway, referred to as prostaglandin
endoperoxide synthase, or fatty acid cyclooxygenase. It is now appreciated that there
are two forms of cyclooxygenase, termed cyclooxygenase-1 or type 1 (COX-1) and
cyclooxygenase-2 or type 2 (COX-2). These isozymes are also known as
Prostaglandin H Synthase (PGHS)-1 and PGHS-2, respectively. Both enzymes
30 catalyze the conversion of arachidonic acid to unstable intermediates, PGG₂ and
PGH₂, which are intermediates in the biosynthesis of prostaglandins and
thromboxanes. COX-1 is present in platelets and endothelial cells and exhibits

constitutive activity. COX-2 has been identified in endothelial cells, macrophages and fibroblasts, including synovial cells after treatment (induction) with cytokines.

The COX-2 isozyme is induced in settings of inflammation by cytokines and inflammatory mediators, such as IL-1, TNF- α and endotoxin, and its expression is upregulated at sites of inflammation. The large increase in activity of COX-2 above basal COX-1 activity concomitant with its upregulation, leads to synthesis of prostaglandins which contribute to pain and inflammation. Because COX-2 is usually expressed only in inflamed tissue or after exposure to mediators of inflammation, selective inhibitors may exhibit anti-inflammatory activity without simultaneous effects on constitutively expressed COX-1 activity present in platelets and other cell types which is considered the cause of undesirable side effects associated with use of nonselective NSAID drugs (e.g., clotting time, bleeding and ulceration).

It has been established that the two COX isozymes are pharmacologically distinct and therefore it has been possible to develop isozyme-specific (selective) cyclooxygenase inhibitors that are useful for anti-inflammatory therapy. A variety of biochemical, cellular and animal assays have been developed to assess the relative selectivity of inhibitors for the COX-1 and COX-2 isoforms. These assays include measurements of prostaglandin E2 production in microsomes prepared from various cell types and bioassay systems using intact human cells. For any given drug, despite experimental variation in the degree of selectivity noted among assay systems and between biological sources, compounds that are selective inhibitors for COX-2 have been identified. In general, a criteria for defining selectivity is the ratio of the COX-1/COX-2 inhibitory constants (or COX-2/COX-1) obtained for a given biochemical or cellular assay system. The selectivity ratio accounts for different absolute IC₅₀ values for inhibition of enzymatic activity that are obtained between microsomal and cellular assay systems (e.g. platelets and macrophages, cell lines stably expressing recombinant human COX isozymes).

Many of the conventional NSAIDs currently on the market (naproxen, indomethacin, ibuprofen) are generally nonselective inhibitors of both isoforms of COX, but may show greater selectivity for COX-1 over COX-2, although this ratio varies for the different compounds. The use of a COX-2 inhibitor to block formation of prostaglandins represents a preferred therapeutic strategy rather than attempting to block interactions of the endogenous prostanoid ligands, (such as PGE₂, which are

produced by COX-2 at the inflammatory site, with any of the eight described subtypes of prostanoid receptors. This approach is not currently feasible since selective and potent antagonists for all of the prostanoid receptors (EP-1, EP-2, EP-3, EP-4, DP, FP, IP and TP) do not exist.

5 A study by Riendeau and coworkers compared the selectivity of more than 45 NSAIDs and selective COX-2 inhibitors using sensitive microsomal and platelet assays for the inhibition of human COX-1 based on the production of prostaglandin E2 by microsomes (Can J. Physiol. Pharmacol (1997) 75:1088-95). In this study, among the compounds that were reported to show selectivity for COX-2 vs. COX1,
10 the rank order of potency was DuP 697 > SC-58451, celecoxib > nimesulide = meloxicam = piroxicam = NS-398 = RS-57067 > SC-57666 > SC-58125 > flosulide > etodolac > L-745,337 > DFU-T-614, with IC₅₀ values ranging from 7 μM to 17 μM. A good correlation was obtained between the IC₅₀ values for the inhibition of microsomal COX-1 and both the inhibition of TXB₂ production by Ca²⁺ ionophore
15 challenged platelets and the inhibition of prostaglandin E2 production by CHO cells stably expressing human COX-1. The microsomal assay was more sensitive to inhibition than cell-based assays and allowed the detection of inhibitory effects on COX-1 for all NSAIDs and selective COX-2 inhibitors examined with discrimination of their potency under conditions of limited availability of arachidonic acid.

20 From the molecular and cellular mechanism of action defined for selective COX-2 inhibitors, such as celecoxib, as well as animal studies, these compounds are expected to exhibit anti-inflammatory action when applied intraoperatively in an irrigation solution directly to a tissue or a joint. In particular, it is expected to be an effective drug delivered by an irrigation solution during an arthroscopic, urologic,
25 cardiovascular or general surgical procedure (periprocedurally). For example, a selective COX-2 inhibitor may replace ketorolac, a relatively non-selective cyclooxygenase inhibitor, in Examples IV, V & VI. The selective COX-2 inhibitor may be delivered alone, or in combination with other small molecule drugs, peptides, proteins, recombinant chimeric proteins, antibodies, or gene therapy vectors (viral
30 and nonviral) to the spaces of the joint, urogenital tract, cardiovascular system or any cavity of the body. For example, the selective COX-2 inhibitor can exert its actions on any cells associated with the fluid spaces of the joint and structures comprising the joint, and which are involved in the normal function of the joint or are present due to a pathological condition. These cells and structures include, but are not

limited to: synovial cells including both Type A fibroblast and type B macrophage cells; the cartilaginous components of the joint such as chondrocytes; cells associated with bone, including periosteal cells, osteoblasts, osteoclasts; the immunological components such as inflammatory cells including lymphocytes, mast cells, monocytes, eosinophils; and other cells like fibroblasts; and combinations of the above cell types.

The selective COX-2 inhibitor may be delivered in a formulation useful for introduction and administration of the drug into the targeted tissue or joint that would enhance the delivery, uptake, stability or pharmacokinetics of the inhibitor drug. The formulation could include, but is not limited to, administration using microparticles, microspheres or nanoparticles composed of lipids, proteins, carbohydrates, synthetic organic compounds, or inorganic compounds. Examples of formulation molecules include, but are not limited to, lipids capable of forming liposomes or other ordered lipid structures, cationic lipids, hydrophilic polymers, polycations (e.g. protamine, spermidine, polylysine), peptide or synthetic ligands and antibodies capable of targeting materials to specific cell types, gels, slow release matrices, soluble and insoluble particles, as well as formulation elements not listed.

The present invention describes the local delivery of a selective COX-2 inhibitor drug using an irrigation solution containing the drug which is present at low concentration and which enables the drug to be delivered directly to the affected tissue or joint. The drug-containing irrigation solution is employed perioperatively during a surgical procedure. Other conventional methods used for drug delivery have required systemic administration (e.g., intramuscular, intravenous, subcutaneous, oral) that necessitates higher concentrations of COX-2 drugs (and higher total dose) to be administered in order to achieve significant therapeutic concentrations in the targeted tissue or joint. Systemic administration also results in high concentrations in tissues other than the targeted tissue that is undesirable and, depending on the dose, may result in adverse side effects (e.g., bleeding, ulceration). These systemic methods of delivery also subject the drug to second pass metabolism and rapid degradation, thereby limiting the duration of the effective therapeutic concentration. The drug in the irrigation solution is administered directly to the desired tissue which provides a significant advantage by allowing the delivery of the selective COX-2 inhibitor drug in a therapeutically effective lower concentration and therapeutically effective lower total dose than by other routes of administration. Furthermore, the

use of a COX-2 inhibitor in the solution in substantially lower dosages than currently used perioperatively may allow the use of this drug in otherwise contraindicated patients.

Representative examples of suitable COX-2 inhibitors for use in connection with the practice of the present invention include, without limitation: celecoxib, meloxicam, nimesulide, nimesulide, diclofenac, flosulide, N-[2-(cyclohexyloxy)-4-nitrophenyl]-methanesulfonamide (NS-398), 1-[(4-methylsulfonyl)phenyl]-3-trifluoromethyl-5-[(4-fluoro)phenyl]pyrazole (SC58125), and the following compounds as described in Riendeau, D. et al., (1997) *Can. J. Physiol. Pharmacol.* 75: 1088-95: DuP 697, SC-58451, RS-57067, SC-57666 and L-745,337. Representative dosage levels for administration in connection with the invention are listed in the Table below.

Cyclooxygenase-2 Inhibitors

Compounds	Therapeutic Preferred Concentrations (μM)	Most Preferred Concentrations (μM)
DuP 697	0.3-3,000	3-500
SC-58451	0.3-3,000	3-500
celecoxib	0.3-3,000	3-500
meloxicam	0.5-5,000	5-1,000
nimesulide	0.5-5,000	5-1,000
diclofenac	0.3-3,000	3-500
NS-398	0.3-3,000	3-500
L-745,337	0.2-10,000	2-2,000
RS57067	0.2-10,000	2-2,000
SC-58125	0.2-10,000	2-2,000
SC-57666	0.2-10,000	2-2,000
flosulide	0.2-10,000	2-2,000

VI. Method of Application

The solution of the present invention has applications for a variety of operative/interventional procedures, including surgical, diagnostic and therapeutic techniques. The irrigation solution is perioperatively applied during arthroscopic surgery of anatomic joints, urological procedures, cardiovascular and general vascular diagnostic and therapeutic procedures and for general surgery. As used herein, the term "perioperative" encompasses application intraprocedurally, pre- and intraprocedurally, intra- and postprocedurally, and pre-, intra- and postprocedurally. Preferably the solution is applied preprocedurally and/or postprocedurally as well as intraprocedurally. Such procedures conventionally utilize physiologic irrigation fluids, such as normal saline or lactated Ringer's, applied to the surgical site by techniques well known to those of ordinary skill in the art. The method of the present invention involves substituting the anti-pain/anti-inflammatory/anti-spasm/anti-restenosis irrigation solutions of the present invention for conventionally applied irrigation fluids. The irrigation solution is applied to the wound or surgical site prior to the initiation of the procedure, preferably before tissue trauma, and continuously throughout the duration of the procedure, to preemptively block pain and inflammation, spasm and restenosis. As used herein throughout, the term "irrigation" is intended to mean the flushing of a wound or anatomic structure with a stream of liquid. The term "application" is intended to encompass irrigation and other methods of locally introducing the solution of the present invention, such as introducing a gellable version of the solution to the operative site, with the gelled solution then remaining at the site throughout the procedure. As used herein throughout, the term "continuously" is intended to also include situations in which there is repeated and frequent irrigation of wounds at a frequency sufficient to maintain a predetermined therapeutic local concentration of the applied agents, and applications in which there may be intermittent cessation of irrigation fluid flow necessitated by operating technique.

The concentrations listed for each of the agents within the solutions of the present invention are the concentrations of the agents delivered locally, in the absence of metabolic transformation, to the operative site in order to achieve a predetermined level of effect at the operative site. It is understood that the drug concentrations in a given solution may need to be adjusted to account for local

dilution upon delivery. For example, in the cardiovascular application, if one assumes an average human coronary artery blood flow rate of 80 cc per minute and an average delivery rate for the solution of 5 cc per minute via a local delivery catheter (i.e., a blood flow-to-solution delivery ratio of 16 to 1), one would require
5 that the drug concentrations within the solution be increased 16-fold over the desired *in vivo* drug concentrations. Solution concentrations are not adjusted to account for metabolic transformations or dilution by total body distribution because these circumstances are avoided by local delivery, as opposed to oral, intravenous, subcutaneous or intramuscular application.

10 Arthroscopic techniques for which the present solution may be employed include, by way of non-limiting example, partial meniscectomies and ligament reconstructions in the knee, shoulder acromioplasties, rotator cuff debridements, elbow synovectomies, and wrist and ankle arthroscopies. The irrigation solution is continuously supplied intraoperatively to the joint at a flow rate sufficient to distend
15 the joint capsule, to remove operative debris, and to enable unobstructed intra-articular visualization.

A suitable irrigation solution for control of pain and edema during such arthroscopic techniques is provided in Example I herein below. For arthroscopy, it is preferred that the solution include a combination, and preferably all, or any of the
20 following: a serotonin₂ receptor antagonist, a serotonin₃ receptor antagonist, a histamine₁ receptor antagonist, a serotonin receptor agonist acting on the 1A, 1B, 1D, 1F and/or 1E receptors, a bradykinin₁ receptor antagonist, a bradykinin₂ receptor antagonist, and a cyclooxygenase inhibitor.

This solution utilizes extremely low doses of these pain and inflammation
25 inhibitors, due to the local application of the agents directly to the operative site during the procedure. For example, less than 0.05 mg of amitriptyline (a suitable serotonin₂ and histamine₁ "dual" receptor antagonist) are needed per liter of irrigation fluid to provide the desired effective local tissue concentrations that would inhibit 5-HT₂ and H₁ receptors. This dosage is extremely low relative to the
30 10-25 mg of oral amitriptyline that is the usual starting dose for this drug. This same rationale applies to the anti-spasm and anti-restenosis agents which are utilized in the solution of the present invention to reduce spasm associated with urologic, cardiovascular and general vascular procedures and to inhibit restenosis associated with cardiovascular and general vascular procedures. For example, less than 0.2 mg
35 of nisoldipine (a suitable calcium channel antagonist) is required per liter of irrigation fluid to provide the desired effective local tissue concentrations that would

inhibit the voltage-dependent gating of the L-subtype of calcium channels. This dose is extremely low compared to the single oral dose of nisoldipine which is 20 to 40 mg.

5 In each of the surgical solutions of the present invention, the agents are included in low concentrations and are delivered locally in low doses relative to concentrations and doses required with conventional methods of drug administration to achieve the desired therapeutic effect. It is impossible to obtain an equivalent therapeutic effect by delivering similarly dosed agents via other (i.e., intravenous, subcutaneous, intramuscular or oral) routes of drug administration since drugs given
10 systemically are subject to first- and second-pass metabolism.

For example, using a rat model of arthroscopy, the inventors examined the ability of amitriptyline, a 5-HT₂ antagonist, to inhibit 5-HT-induced plasma extravasation in the rat knee in accordance with the present invention. This study, described more fully below in Example XII, compared the therapeutic dosing of
15 amitriptyline delivered locally (i.e., intra-articularly) at the knee and intravenously. The results demonstrated that intra-articular administration of amitriptyline required total dosing levels approximately 200-fold less than were required via the intravenous route to obtain the same therapeutic effect. Given that only a small fraction of the drug delivered intra-articularly is absorbed by the local synovial
20 tissue, the difference in plasma drug levels between the two routes of administration is much greater than the difference in total amitriptyline dosing levels.

Practice of the present invention should be distinguished from conventional intra-articular injections of opiates and/or local anesthetics at the completion of arthroscopic or "open" joint (e.g., knee, shoulder, etc.) procedures. The solution of
25 the present invention is used for continuous infusion throughout the surgical procedure to provide preemptive inhibition of pain and inflammation. In contrast, the high concentrations necessary to achieve therapeutic efficacy with a constant infusion of local anesthetics, such as lidocaine (0.5-2% solutions), would result in profound systemic toxicity.

30 Upon completion of the procedure of the present invention, it may be desirable to inject or otherwise apply a higher concentration of the same pain and inflammation inhibitors as used in the irrigation solution at the operative site, as an alternative or supplement to opiates.

35 The solution of the present invention also has application in cardiovascular and general vascular diagnostic and therapeutic procedures to potentially decrease vessel wall spasm, platelet aggregation, vascular smooth muscle cell proliferation

and nociceptor activation produced by vessel manipulation. Reference herein to arterial treatment is intended to encompass the treatment of venous grafts harvested and placed in the arterial system. A suitable solution for such techniques is disclosed in Example II herein below. The cardiovascular and general vascular solution preferably includes any combination, and preferably all, of the following: a 5-HT₂ receptor antagonist (Saxena, P. R., et. al., *Cardiovascular Effects of Serotonin Inhibitory Agonists and Antagonists*, J Cardiovasc Pharmacol 15 (Suppl. 7), pp. S17-S34 (1990); Douglas, 1985); a 5-HT₃ receptor antagonist to block activation of these receptors on sympathetic neurons and C-fiber nociceptive neurons in the vessel walls, which has been shown to produce brady- and tachycardia (Saxena et. al. 1990); a bradykinin₁ receptor antagonist; and a cyclooxygenase inhibitor to prevent production of prostaglandins at tissue injury sites and thereby decreasing pain and inflammation. In addition, the cardiovascular and general vascular solution also preferably will contain a serotonin_{1B} (also known as serotonin_{1D β}) antagonist because serotonin has been shown to produce significant vascular spasm via activation of the serotonin_{1B} receptors in humans. Kaumann, A.J., et al., *Variable Participation of 5-HT₁-Like Receptors and 5-HT₂ Receptors in Serotonin-Induced Contraction of Human Isolated Coronary Arteries*, Circulation 90, pp. 1141-53 (1994). This excitatory action of serotonin_{1B} receptors in vessel walls, resulting in vasoconstriction, is in contrast to the previously-discussed inhibitory action of serotonin_{1B} receptors in neurons. The cardiovascular and general vascular solution of the present invention also may suitably include one or more of the anti-restenosis agents disclosed herein that reduce the incidence and severity of post-procedural restenosis resulting from, for example, angioplasty or rotational atherectomy.

The solution of the present invention also has utility for reducing pain and inflammation associated with urologic procedures, such as trans-urethral prostate resection and similar urologic procedures. References herein to application of solution to the urinary tract or to the urological structures is intended to include application to the urinary tract per se, bladder and prostate and associated structures. Studies have demonstrated that serotonin, histamine and bradykinin produce inflammation in lower urinary tract tissues. Schwartz, M.M., et. al., *Vascular Leakage in the Kidney and Lower Urinary Tract: Effects of Histamine, Serotonin and Bradykinin*, Proc Soc Exp Biol Med 140, pp. 535-539 (1972). A suitable irrigation solution for urologic procedures is disclosed in Example III herein below. The solution preferably includes a combination, and preferably all, of the following: a histamine₁ receptor antagonist to inhibit histamine-induced pain and inflammation;

a 5-HT₃ receptor antagonist to block activation of these receptors on peripheral C-fiber nociceptive neurons; a bradykinin₁ antagonist; a bradykinin₂ antagonist; and a cyclooxygenase inhibitor to decrease pain/inflammation produced by prostaglandins at the tissue injury sites. Preferably an anti-spasm agent is also included to prevent spasm in the urethral canal and bladder wall.

Some of the solutions of the present invention may suitably also include a gelling agent to produce a dilute gel. This gellable solution may be applied, for example, within the urinary tract or an arterial vessel to deliver a continuous, dilute local predetermined concentration of agents.

The solution of the present invention may also be employed perioperatively for the inhibition of pain and inflammation in surgical wounds, as well as to reduce pain and inflammation associated with burns. Burns result in the release of a significant quantity of biogenic amines, which not only produce pain and inflammation, but also result in profound plasma extravasation (fluid loss), often a life-threatening component of severe burns. Holliman, C.J., et. al., *The Effect of Ketanserin, a Specific Serotonin Antagonist, on Burn Shock Hemodynamic Parameters in a Porcine Burn Model*, J Trauma 23, pp. 867-871 (1983). The solution disclosed in Example I for arthroscopy may also be suitably applied to a wound or burn for pain and inflammation control, and for surgical procedures such as arthroscopy. The agents of the solution of Example I may alternately be included in a paste or salve base, for application to the burn or wound.

VII. Examples

The following are several formulations in accordance with the present invention suitable for certain operative procedures followed by a summary of three clinical studies utilizing the agents of the present invention.

A. Example I

Irrigation Solution for Arthroscopy

The following composition is suitable for use in anatomic joint irrigation during arthroscopic procedures. Each drug is solubilized in a carrier fluid containing physiologic electrolytes, such as normal saline or lactated Ringer's solution, as are the remaining solutions described in subsequent examples.

<u>Class of Agent</u>	<u>Drug</u>	<u>Concentration (Nanomolar): Therapeutic</u>	<u>Preferred</u>	<u>Most Preferred</u>
serotonin ₂ antagonist	amitriptyline	0.1-1,000	50-500	100
serotonin ₃ antagonist	metoclopramide	10-10,000	200-2,000	1,000
histamine ₁ antagonist	amitriptyline	0.1-1,000	50-500	200
serotonin _{1A, 1B, 1D, 1F} agonist	sumatriptan	1-1,000	10-200	50
bradykinin ₁ antagonist	[des-Arg ¹⁰] derivative of HOE 140	1-1,000	50-500	200
bradykinin ₂ antagonist	HOE 140	1-1,000	50-500	200

B. Example II

Irrigation Solution for Cardiovascular and General Vascular Therapeutic and Diagnostic Procedures

5 The following drugs and concentration ranges in solution in a physiologic carrier fluid are suitable for use in irrigating operative sites during cardiovascular and general vascular procedures.

<u>Class of Agent</u>	<u>Drug</u>	<u>Concentration (Nanomolar): Therapeutic</u>	<u>Preferred</u>	<u>Most Preferred</u>
serotonin ₂ antagonist	trazodone	0.1-2,000	50-500	200
serotonin ₃ antagonist	metoclopramide	10-10,000	200-2,000	1,000
serotonin _{1B} antagonist	yohimbine	0.1-1,000	50-500	200
bradykinin ₁ antagonist	[des-Arg ¹⁰] derivative of HOE 140	1-1,000	50-500	200
cyclooxygenase inhibitor	ketorolac	100-10,000	500-5,000	3,000

C. Example IIIIrrigation Solution for Urologic Procedures

The following drugs and concentration ranges in solution in a physiologic carrier fluid are suitable for use in irrigating operative sites during urologic procedures.

<u>Class of Agent</u>	<u>Drug</u>	<u>Concentration (Nanomolar): Therapeutic</u>	<u>Preferred</u>	<u>Most Preferred</u>
histamine ₁ antagonist	terfenadine	0.1-1,000	50-500	200
serotonin ₃ antagonist	metoclopramide	10-10,000	200-2,000	1,000
bradykinin ₁ antagonist	[des-Arg ¹⁰] derivative of HOE 140	1-1,000	50-500	200
bradykinin ₂ antagonist	HOE 140	1-1,000	50-500	200
cyclooxygenase inhibitor		100-10,000	500-5,000	3,000

D. Example IVIrrigation Solution for Arthroscopy, Burns, General Surgical Wounds and Oral/Dental Applications

5 The following composition is preferred for use in anatomic irrigation during arthroscopic and oral/dental procedures and the management of burns and general surgical wounds. While the solution set forth in Example I is suitable for use with the present invention, the following solution is even more preferred because of expected higher efficacy.

<u>Class of Agent</u>	<u>Drug</u>	<u>Concentration (Nanomolar):</u>		<u>Most Preferred</u>
		<u>Therapeutic</u>	<u>Preferred</u>	
serotonin ₂ antagonist	amitriptyline	0.1 - 1,000	50 - 500	200
serotonin ₃ antagonist	metoclopramide	10 - 10,000	200 - 2,000	1,000
histamine ₁ antagonist	amitriptyline	0.1 - 1,000	50 - 500	200
serotonin _{1A, 1B, 1D, 1F} agonist	sumatriptan	1 - 1,000	10 - 200	100
cyclooxygenase inhibitor	ketorolac	100 - 10,000	500 - 5,000	3,000
neurokinin ₁ antagonist	GR 82334	1 - 1,000	10 - 500	200
neurokinin ₂ antagonist	(±) SR 48968	1 - 1,000	10 - 500	200
purine _{2X} antagonist	PPADS	100 - 100,000	10,000- 100,000	50,000
ATP-sensitive K ⁺ channel agonist	(-) pinacidil	1 - 10,000	100 - 1,000	500
Ca ²⁺ channel antagonist	nifedipine	1 - 10,000	100 - 5,000	1,000

kallikrein inhibitor	aprotinin	0.1 - 1,000	50 - 500	200
----------------------	-----------	-------------	----------	-----

E. Example V

Alternate Irrigation Solution for Cardiovascular and General Vascular Therapeutic and Diagnostic Procedures

5 The following drugs and concentration ranges in solution in a physiologic carrier fluid are preferred for use in irrigating operative sites during cardiovascular and general vascular procedures. Again, this solution is preferred relative to the solution set forth in Example II above for higher efficacy.

<u>Class of Agent</u>	<u>Drug</u>	<u>Concentration (Nanomolar): Therapeutic</u>	<u>Preferred</u>	<u>Most Preferred</u>
serotonin ₂ antagonist	trazodone	0.1 - 2,000	50 - 500	200
cyclooxygenase inhibitor	ketorolac	100 - 10,000	500 - 5,000	3,000
endothelin antagonist	BQ 123	0.01 - 1,000	10 - 1,000	500
ATP-sensitive K ⁺ channel agonist	(-) pinacidil	1 - 10,000	100 - 1,000	500
Ca ²⁺ channel antagonist	nisoldipine	1 - 10,000	100 - 1,000	500
nitric oxide donor	SIN-1	10 - 10,000	100 - 1,000	500

F. Example VIAlternate Irrigation Solution for Urologic Procedures

The following drugs and concentration ranges in solution in a physiologic carrier fluid are preferred for use in irrigating operative sites during urologic procedures. The solution is believed to have even higher efficacy than the solution set forth in prior Example III.

<u>Class of Agent</u>	<u>Drug</u>	<u>Concentration (Nanomolar):</u>		<u>Most Preferred</u>
		<u>Therapeutic</u>	<u>Preferred</u>	
serotonin ₂ antagonist	LY 53857	0.1 - 500	1 - 100	50
histamine ₁ antagonist	terfenadine	0.1 - 1,000	50 - 500	200
cyclooxygenase inhibitor	ketorolac	100 - 10,000	500 - 5,000	3,000
neurokinin ₂ antagonist	SR 48968	1 - 1,000	10 - 500	200
purine _{2X} antagonist	PPADS	100 - 100,000	10,000-100,000	50,000
ATP-sensitive K ⁺ channel agonist	(-) pinacidil	1 - 10,000	100 - 1,000	500
Ca ²⁺ channel antagonist	nifedipine	1 - 10,000	100 - 5,000	1,000
kallikrein inhibitor	aprotinin	0.1 - 1,000	50 - 500	200
nitric oxide donor	SIN-1	10 - 10,000	100 - 1,000	500

G. Example VIICardiovascular and General Vascular Anti-Restenosis Irrigation Solution

The following drugs and concentration ranges in solution in a physiologic carrier fluid are preferred for use in irrigation during cardiovascular and general vascular therapeutic and diagnostic procedures. The drugs in this preferred solution may also be added at the same concentration to the cardiovascular and general vascular irrigation solutions of Examples II and V described above or Example VIII described below for preferred anti-spasmodic, anti-restenosis, anti-pain/anti-inflammation solutions.

10

<u>Class of Agent</u>	<u>Drug</u>	<u>Concentration (Nanomolar): Therapeutic</u>	<u>Preferred</u>	<u>Most Preferred</u>
thrombin inhibitor	hirulog	0.2-20,000	2-2,000	200
glycoprotein IIb/IIIa receptor blocker	integrelin	0.1-10,000 x Kd	1-1000 x Kd	100 x Kd
PKC inhibitor	GF 109203X*	0.1-10,000	1-1,000	200
protein tyrosine kinase inhibitor	tyrphostin AG1296	10-100,000	100-20,000	10,000

* Also known as Go 6850 or Bisindoylmaleimide I (available from Warner-Lambert)

H. Example VIII

Alternate Irrigation Solution for Cardiovascular and General Vascular Therapeutic and Diagnostic Procedures

An additional preferred solution for use in cardiovascular and general vascular therapeutic and diagnostic procedures is formulated the same as the previously described formulation of Example V, except that the nitric oxide (NO donor) SIN-1 is replaced by a combination of two agents, FK 409 (NOR-3) and FR 144420 (NOR-4), at the concentrations set forth below:

<u>Class of Agent</u>	<u>Drug</u>	<u>Concentration (Nanomolar):</u>		<u>Most Preferred</u>
		<u>Therapeutic</u>	<u>Preferred</u>	
NO donor	FK 409 (NOR-3)	1-1,000	10-500	250
NO donor	FR 144420 (NOR-4)	10-10,000	100-5,000	1,000

I. Example IXAlternate Irrigation Solution for Arthroscopy, General Surgical Wounds,
Burns and Oral/Dental Applications

An alternate preferred solution for use in irrigation of arthroscopic, general
5 surgical and oral/dental applications is formulated the same as in the previously
described Example IV, with the following substitution, deletion and additions at the
concentrations set forth below:

- 1) amitriptyline is replaced by mepyramine as the H₁ antagonist;
- 2) the kallikrein inhibitor, aprotinin, is deleted;
- 10 3) a bradykinin₁ antagonist, [leu⁹] [des-Arg¹⁰] kalliden, is added;
- 4) a bradykinin₂ antagonist, HOE 140, is added; and
- 5) a μ -opioid agonist, fentanyl, is added.

<u>Class of Agent</u>	<u>Drug</u>	Concentration (Nanomolar): <u>Therapeutic</u>	<u>Preferred</u>	<u>Most Preferred</u>
H ₁ antagonist	mepyramine	0.1-1,000	5-200	100
bradykinin ₁ antagonist	[leu ⁹][des-Arg ¹⁰] kalliden	0.1-500	10-200	100
bradykinin ₂ antagonist	HOE 140	1-1,000	50-500	200
μ -opioid agonist	fentanyl	0.1-500	10-200	100

J. Example X

Alternate Irrigation solution for Urologic Procedures

An alternate preferred solution for use in irrigation during urologic procedures is formulated the same as in the previously described Example VI with the following substitution, deletion and additions at the concentrations set forth below:

- 1) SIN-1 is replaced as the NO donor by a combination of two agents:
 - a) FK 409 (NOR-3); and
 - b) FR 144420 (NOR-4);
- 2) the kallikrein inhibitor, aprotinin, is deleted;
- 3) a bradykinin₁ antagonist, [leu⁹] [des-Arg¹⁰] kalliden, is added; and
- 4) a bradykinin₂ antagonist, HOE 140, is added.

<u>Class of Agent</u>	<u>Drug</u>	<u>Concentration (Nanomolar):</u>		<u>Most Preferred</u>
		<u>Therapeutic</u>	<u>Preferred</u>	
NO donor	FK 409 (NOR-3)	1-1,000	10-500	250
NO donor	FR 144420 (NOR-4)	10-10,000	100-5,000	1,000
bradykinin ₁ antagonist	[leu ⁹][des-Arg ¹⁰] kalliden	0.1-500	10-200	100
bradykinin ₂ antagonist	HOE 140	1-1,000	50-500	200

K. Example XI

15 Balloon Dilatation of Normal Iliac Arteries in the New Zealand White Rabbit and the Influence of Histamine/Serotonin Receptor Blockade on the Response

The purpose of this study was twofold. First, a new *in vivo* model for the study of arterial tone was employed. The time course of arterial dimension changes

before and after balloon angioplasty is described below. Second, the role of histamine and serotonin together in the control of arterial tone in this setting was then studied by the selective infusion of histamine and serotonin receptor blocking agents into arteries before and after the angioplasty injury.

5

1. Design Considerations

This study was intended to describe the time course of change in arterial lumen dimensions in one group of arteries and to evaluate the effect of histamine/serotonin receptor blockade on these changes in a second group of similar arteries. To facilitate the comparison of the two different groups, both groups were treated in an identical manner with the exception of the contents of an infusion performed during the experiment. In control animals (arteries), the infusion was normal saline (the vehicle for test solution). The histamine/serotonin receptor blockade treated arteries received saline containing the receptor antagonists at the same rate and at the same part of the protocol as control animals. Specifically, the test solution included: (a) the serotonin₃ antagonist metoclopramide at a concentration of 16.0 μ M; (b) the serotonin₂ antagonist trazodone at a concentration of 1.6 μ M; and (c) the histamine antagonist promethazine at concentrations of 1.0 μ M, all in normal saline. Drug concentrations within the test solution were 16-fold greater than the drug concentrations delivered at the operative site due to a 16 to 1 flow rate ratio between the iliac artery (80 cc per minute) and the solution delivery catheter (5 cc per minute). This study was performed in a prospective, randomized and blinded manner. Assignment to the specific groups was random and investigators were blinded to infusion solution contents (saline alone or saline containing the histamine/serotonin receptor antagonists) until the completion of the angiographic analysis.

25

2. Animal Protocol

This protocol was approved by the Seattle Veteran Affairs Medical Center Committee on Animal Use and the facility is fully accredited by the American Association for Accreditation of Laboratory Animal Care. The iliac arteries of 3-4 kg male New Zealand white rabbits fed a regular rabbit chow were studied. The animals were sedated using intravenous xylazine (5 mg/kg) and ketamine (35 mg/kg) dosed to effect and a cutdown was performed in the ventral midline of the neck to isolate a carotid artery. The artery was ligated distally, an arteriotomy performed and a 5 French sheath was introduced into the descending aorta. Baseline blood pressure

30

and heart rate were recorded and then an angiogram of the distal aorta and bilateral iliac arteries was recorded on 35 mm cine film (frame rate 15 per second) using hand injection of iopamidol 76% (Squibb Diagnostics, Princeton, NJ) into the descending aorta. For each angiogram, a calibration object was placed in the radiographic field of view to allow for correction for magnification when diameter measurements were made. A 2.5 French infusion catheter (Advanced Cardiovascular Systems, Santa Clara, CA) was placed through the carotid sheath and positioned 1-2 cm above the aortic bifurcation. Infusion of the test solution -- either saline alone or saline containing the histamine/serotonin receptor antagonists -- was started at a rate of 5 cc per minute and continued for 15 minutes. At 5 minutes into the infusion, a second angiogram was performed using the previously described technique then a 2.5 mm balloon angioplasty catheter (the Lightning, Cordis Corp., Miami, FL) was rapidly advanced under fluoroscopic guidance into the left and then the right iliac arteries. In each iliac the balloon catheter was carefully positioned between the proximal and distal deep femoral branches using bony landmarks and the balloon was inflated for 30 seconds to 12 ATM of pressure. The balloon catheter was inflated using a dilute solution of the radiographic contrast agent so that the inflated balloon diameter could be recorded on cine film. The angioplasty catheter was rapidly removed and another angiogram was recorded on cine film at a mean of 8 minutes after the infusion was begun. The infusion was continued until the 15 minute time point and another angiogram (the fourth) was performed. Then the infusion was stopped (a total of 75 cc of solution had been infused) and the infusion catheter was removed. At the 30 minute time point (15 minutes after the infusion was stopped), a final angiogram was recorded as before. Blood pressure and heart rate were recorded at the 15 and 30 minute time points immediately before the angiograms. After the final angiogram, the animal was euthanized with an overdose of the anesthetic agents administered intravenously and the iliac arteries were retrieved and immersion fixed in formation for histologic analysis.

3. Angiographic Analysis

The angiograms were recorded on 35 mm cine film at a frame rate of 15 per second. For analysis, the angiograms were projected from a Vanguard projector at a distance of 5.5 feet. Iliac artery diameters at prespecified locations relative to the balloon angioplasty site were recorded based on hand held caliper measurement after correction for magnification by measurement of the calibration object. Measurements were made at baseline (before test solution infusion was begun),

5 minutes into the infusion, immediately post balloon angioplasty (a mean of 8 minutes after the test solution was begun), at 15 minutes (just before the infusion was stopped) and at 30 minutes (15 minutes after the infusion was stopped). Diameter measurements were made at three sites in each iliac artery: proximal to the site of balloon dilatation, at the site of balloon dilatation and just distal to the site of balloon dilatation.

The diameter measurements were then converted to area measurements by the formula:

$$\text{Area} = (\text{Pi})(\text{Diameter}^2)/4.$$

For calculation of vasoconstriction, baseline values were used to represent the maximum area of the artery and percent vasoconstriction was calculated as: % Vasoconstriction = $\{(\text{Baseline area} - \text{Later time point area})/\text{Baseline area}\} \times 100$.

4. Statistical Methods

All values are expressed as mean \pm 1 standard error of the mean. The time course of vasomotor response in control arteries was assessed using one way analysis of variance with correction for repeated measures. Post hoc comparison of data between specific time points was performed using the Scheffe test. Once the time points at which significant vasoconstriction occurred had been determined in control arteries, the control and histamine/serotonin receptor antagonist treated arteries were compared at those time points where significant vasoconstriction occurred in control arteries using multiple analysis of variance with treatment group identified as an independent variable. To compensate for the absence of a single a priori stated hypothesis, a p value <0.01 was considered significant. Statistics were performed using Statistica for Windows, version 4.5, (Statsoft, Tulsa, OK).

5. Results

The time course of arterial dimension changes before and after balloon angioplasty in normal arteries receiving saline infusion was evaluated in 16 arteries from 8 animals (Table 23). Three segments of each artery were studied: the proximal segment immediately upstream from the balloon dilated segment, the balloon dilated segment and the distal segment immediately downstream from the balloon dilated segment. The proximal and distal segments demonstrated similar patterns of change in arterial dimensions: in each, there was significant change in

arterial diameter when all time points were compared (proximal segment, $p=0.0002$ and distal segment, $p<0.001$, ANOVA). Post hoc testing indicated that the diameters at the immediate post angioplasty time point were significantly less than the diameters at baseline or at the 30 minute time point in each of these segments. On the other hand, the arterial diameters in each segment at the 5 minute, 15 minute and 30 minute time points were similar to the baseline diameters. The balloon dilated segment showed lesser changes in arterial dimension than the proximal and distal segments. The baseline diameter of this segment was 1.82 ± 0.05 mm; the nominal inflated diameter of the balloon used for angioplasty was 2.5 mm and the actual measured inflated diameter of the balloon was 2.20 ± 0.03 mm ($p<0.0001$ vs. baseline diameter of the balloon treated segment). Thus, the inflated balloon caused circumferential stretch of the balloon dilated segment, but there was only slight increase in lumen diameter from baseline to the 30 minute time point (1.82 ± 0.05 mm to 1.94 ± 0.07 mm, $p=NS$ by post hoc testing).

15

Table 23

Angiographically determined lumen diameters at the specified times before and after balloon dilatation of normal iliac arteries.

Segment	Baseline	5 Minute	Immediate Post PTA	15 Minute	30 Minute
Proximal ¹	2.18 ± 0.7	2.03 ± 0.7	$1.81\pm 0.08^*$	2.00 ± 0.8	2.23 ± 0.8
Balloon ²	1.82 ± 0.05	1.77 ± 0.03	1.79 ± 0.05	1.70 ± 0.04	1.94 ± 0.07
Distal ³	1.76 ± 0.04	$1.68\pm 0.04^{**}$	$1.43\pm 0.04^*$	1.54 ± 0.03	1.69 ± 0.06

20

All measurements in mm. Means \pm SEM. PTA = percutaneous transluminal angioplasty.

¹ $p=0.0002$ (ANOVA within group comparison), ² $p=0.03$ (ANOVA within group comparison),

³ $p<0.0001$ (ANOVA within group comparison). N=16 at all time points.

25

* $p<0.01$ versus baseline and 30 minute diameter measurements (Scheffe test for post hoc comparisons).

** $p < 0.01$ versus immediate post PTA measurements (Scheffe test for post hoc comparisons). All other post hoc comparisons were not significant using the $p < 0.01$ threshold.

Arterial lumen diameters were used to calculate lumen area then the area measurements were used to calculate percent vasoconstriction by comparison of the 5 minute, immediate post angioplasty, 15 and 30 minute data to the baseline measurements. The proximal and distal segment data expressed as percent vasoconstriction are shown in FIGURE 9; the changes in the amount of vasoconstriction over time are significant (in the proximal segment, $p = 0.0008$; in the distal segment, $p = 0.0001$, ANOVA). Post hoc testing identifies the vasoconstriction at the immediate post angioplasty time point as significantly different from that present at the 30 minute time point ($P < 0.001$ in both segments). In the distal segment, the immediate post angioplasty vasoconstriction was also significantly less than that at 5 minutes ($p < 0.01$); no other differences in intra-time point comparisons were significant by post hoc testing.

The luminal changes in control arteries can be summarized as follows: 1) Vasoconstriction with loss of approximately 30% of baseline luminal area occurs in the segments of artery proximal and distal to the balloon dilated segment immediately after balloon dilatation. There are trends to smaller amounts of vasoconstriction in the proximal and distal segments before dilatation and at the 15 minute time point (approximately 7 minutes after dilatation) also but, by the 30 minute time point (approximately 22 minutes after dilatation), a trend towards vasodilatation has replaced the previous vasoconstriction; 2) In the balloon dilated segment, only minor changes in lumen dimensions are present, and, despite the use of a balloon with a significantly larger inflated diameter than was present in this segment at baseline, there was no significant increase in lumen diameter of the dilated segment. These findings lead to a conclusion that any effects of the putative histamine/serotonin treatment would only be detectable in the proximal and distal segments at the time points where vasoconstriction was present.

The histamine/serotonin receptor blockade solution was infused into 16 arteries (8 animals); angiographic data was available at all time points in 12 arteries. Heart rate and systolic blood pressure measurements were available in a subset of animals (Table 24). There were no differences in heart rate or systolic blood pressure when the two animal groups were compared within specific time points. Histamine/serotonin treated animals showed trends toward a decrease in the

systolic blood pressure from baseline to 30 minutes (-14 ± 5 mm Hg, $p=0.04$) and a lower heart rate (-26 ± 10 , $p=0.05$). Within the control animals, there was no change in heart rate or systolic blood pressure over the duration of the experiment.

Table 24

5 Systolic blood pressure and heart rate measurements in control and
 histamine/serotonin treated animals.

Group	Baseline (N)	5 Minute (N)	15 Minute (N)	30 Minute (N)
Systolic Blood Pressure				
Control	83±4 (8)	84±4 (8)	82±6 (8)	80±4 (8)
Histamine/Serotonin	93±5 (6)	87±9 (4)	82±9 (6)	80±8 (6)*
Heart Rate				
Control	221±18 (5)	234±18 (4)	217±23 (5)	227±22 (5)
Histamine/Serotonin	232±8 (5)	232±8 (5)	209±14 (5)	206±12 (5)**

Systolic blood pressure in mm Hg and heart rate in beats per minute. Mean±SEM.

* $p=0.04$ for decrease in systolic blood pressure from baseline to 30 minutes and

10

** $p=0.05$ for decrease in heart rate from baseline to 30 minutes within the histamine/serotonin treated animals.

15 The proximal and distal segments of histamine/serotonin treated arteries were
 compared to control arteries using the percent vasoconstriction measurement.
 FIGURE 10A shows the effects of the histamine/serotonin infusion on proximal
 segment vasoconstriction relative to the vasoconstriction present in the control
 arteries. When the findings in the two treatment groups were compared at the
 baseline, immediate post angioplasty and 15 minute time points, histamine/serotonin
 20 infusion resulted in significantly less vasoconstriction compared to the control saline
 infusion ($p=0.003$, 2-way ANOVA). Comparison of the two treatment groups in the
 distal segment is illustrated in FIGURE 10B. Despite observed differences in mean
 diameter measurements in the distal segment, solution treated vessels exhibited less
 vasoconstriction than saline treated control vessels at baseline, immediate post-
 25 angioplasty and 15 minute time points, this pattern did not achieve statistical

significance ($p=0.32$, 2-way ANOVA). Lack of statistical significance may be attributed to smaller than expected vasoconstriction values in the control vessels.

L. Example XII

5 Amitriptyline Inhibition of 5-Hydroxytryptamine-Induced Knee Joint Plasma Extravasation - Comparison of Intra-Articular Versus Intravenous Routes of Administration

10 The following study was undertaken in order to compare two routes of administration of the 5-HT₂ receptor antagonist, amitriptyline: 1) continuous intra-articular infusion; versus 2) intravenous injection, in a rat knee synovial model of inflammation. The ability of amitriptyline to inhibit 5-HT-induced joint plasma extravasation by comparing both the efficacy and total drug dose of amitriptyline delivered via each route was determined.

1. Animals

15 Approval from the Institutional Animal Care Committee at the University of California, San Francisco was obtained for these studies. Male Sprague-Dawley rats (Bantin and Kingman, Fremont, CA) weighing 300 - 450 g were used in these studies. Rats were housed under controlled lighting conditions (lights on 6 A.M. to 6 P.M.), with food and water available *ad libitum*.

2. Plasma Extravasation

20 Rats were anesthetized with sodium pentobarbital (65 mg/kg) and then given a tail vein injection of Evans Blue dye (50 mg/kg in a volume of 2.5 ml/kg), which is used as a marker for plasma protein extravasation. The knee joint capsule was exposed by excising the overlying skin, and a 30-gauge needle was inserted into the joint and used for the infusion of fluid. The infusion rate (250 μ l/min) was controlled
25 by a Sage Instruments Syringe pump (Model 341B, Orion Research Inc., Boston, MA). A 25-gauge needle was also inserted into the joint space and perfusate fluid was extracted at 250 μ l/min, controlled by a Sage Instruments Syringe pump (Model 351).

30 The rats were randomly assigned to three groups: 1) those receiving only intra-articular (IA) 5-HT (1 μ M), 2) those receiving amitriptyline intravenously (IV) (doses ranging from 0.01 to 1.0 mg/kg) followed by IA 5-HT (1 mM), and 3) those receiving amitriptyline intra-articularly (IA) (concentrations ranging from 1 to 100 μ M) followed by IA 5-HT (1 μ M) plus IA amitriptyline. In all groups, baseline plasma extravasation levels were obtained at the beginning of each experiment by

perfusing 0.9% saline intra-articularly and collecting three perfusate samples over a 15 min period (one every 5 min). The first group was then administered 5-HT IA for a total of 25 min. Perfusate samples were collected every 5 min for a total of 25 min. Samples were then analyzed for Evans Blue dye concentration by spectrophotometric measurement of absorbance at 620 nm, which is linearly related to its concentration (Carr and Wilhelm, 1964). The IV amitriptyline group was administered the drug during the tail vein injection of the Evans Blue dye. The knee joints were then perfused for 15 min with saline (baseline), followed by 25 min perfusion with 5-HT (1 μ M). Perfusate samples were collected every 5 min for a total of 25 min. Samples were then analyzed using spectrophotometry. In the IA amitriptyline group, amitriptyline was perfused intra-articularly for 10 min after the 15 min saline perfusion, then amitriptyline was perfused in combination with 5-HT for an additional 25 min. Perfusate samples were collected every 5 min and analyzed as above.

Some rat knees were excluded from the study due to physical damage of knee joint or inflow and outflow mismatch (detectable by presence of blood in perfusate and high baseline plasma extravasation levels or knee joint swelling due to improper needle placement).

a. 5-HT-Induced Plasma Extravasation

Baseline plasma extravasation was measured in all knee joints tested (total n=22). Baseline plasma extravasation levels were low, averaging 0.022 ± 0.003 absorbance units at 620 nm (average \pm standard error of the mean). This baseline extravasation level is shown in FIGURES 11 and 12 as a dashed line.

5-HT (1 μ M) perfused into the rat knee joint produces a time-dependent increase in plasma extravasation above baseline levels. During the 25 min perfusion of 5-HT intra-articularly, maximum levels of plasma extravasation were achieved by 15 min and continued until the perfusion was terminated at 25 min (data not shown). Therefore, 5-HT-induced plasma extravasation levels reported are the average of the 15, 20 and 25 min time points during each experiment. 5-HT-induced plasma extravasation averaged 0.192 ± 0.011 , approximately an 8-fold stimulation above baseline. This data is graphed in FIGURES 11 and 12, corresponding to the "0" dose of IV amitriptyline and the "0" concentration of IA amitriptyline, respectively.

b. Effect of Intravenous Amitriptyline on 5-HT-Induced Plasma Extravasation

Amitriptyline administered via tail vein injection produced a dose-dependent decrease in 5-HT-induced plasma extravasation as shown in FIGURE 11. The IC_{50}

for IV amitriptyline inhibition of 5-HT-induced plasma extravasation is approximately 0.025 mg/kg. 5-HT-induced plasma extravasation is completely inhibited by an IV amitriptyline dose of 1 mg/kg, the plasma extravasation averaging 0.034 ± 0.010 .

5 c. Effect of Intra-articular amitriptyline on 5-HT-Induced Plasma Extravasation

Amitriptyline administered alone in increasing concentrations intra-articularly did not affect plasma extravasation levels relative to baseline, with the plasma extravasation averaging 0.018 ± 0.002 (data not shown). Amitriptyline co-perfused in increasing concentrations with 5-HT produced a concentration-dependent decrease
10 in 5-HT-induced plasma extravasation as shown in FIGURE 12. 5-HT-induced plasma extravasation in the presence of 3 μM IA amitriptyline was not significantly different from that produced by 5-HT alone, however, 30 μM amitriptyline co-perfused with 5-HT produced a greater than 50% inhibition, while 100 μM amitriptyline produced complete inhibition of 5-HT-induced plasma extravasation.
15 The IC_{50} for IA amitriptyline inhibition of 5-HT-induced plasma extravasation is approximately 20 μM .

The major finding of the present study is that 5-HT (1 μM) perfused intra-articularly in the rat knee joint produces a stimulation of plasma extravasation that is approximately 8-fold above baseline levels and that either intravenous or intra-
20 articular administration of the 5-HT₂ receptor antagonist, amitriptyline, can inhibit 5-HT-induced plasma extravasation. The total dosage of administered amitriptyline, however, differs dramatically between the two methods of drug delivery. The IC_{50} for IV amitriptyline inhibition of 5-HT-induced plasma extravasation is 0.025 mg/kg, or 7.5×10^{-3} mg in a 300 g adult rat. The IC_{50} for IA amitriptyline inhibition of
25 5-HT-induced plasma extravasation is approximately 20 μM . Since 1 ml of this solution was delivered every five minutes for a total of 35 min during the experiment, the total dosage perfused into the knee was 7 ml, for a total dosage of 4.4×10^{-5} mg perfused into the knee. This IA amitriptyline dose is approximately 200-fold less than the IV amitriptyline dose. Furthermore, it is likely that only a small fraction of
30 the IA perfused drug is systemically absorbed, resulting in an even greater difference in the total delivered dose of drug.

Since 5-HT may play an important role in surgical pain and inflammation, as discussed earlier, 5-HT antagonists such as amitriptyline may be beneficial if used during the perioperative period. A recent study attempted to determine the effects of
35 oral amitriptyline on post-operative orthopedic pain (Kerrick et al., 1993). An oral

dose as low as 50 mg produced undesirable central nervous system side-effects, such as a "decreased feeling of well-being". Their study, in addition, also showed that oral amitriptyline produced higher pain scale scores than placebo ($P < 0.05$) in the post-operative patients. Whether this was due to the overall unpleasantness produced by oral amitriptyline is not known. In contrast, an intra-articular route of administration allows an extremely low concentration of drug to be delivered locally to the site of inflammation, possibly resulting in maximal benefit with minimal side-effects.

M. Example XIII

10 Effects Of Cardiovascular and General Vascular Solution On Rotational Atherectomy-Induced Vasospasm In Rabbit Arteries

1. Solution Tested

This study utilized an irrigation solution consisting of the agents set forth in Example V. above, with the following exceptions. Nitroprusside replaced SIN-1 as the nitric oxide donor and nicardipine replaced nisoldipine as the Ca^{2+} channel antagonist.

The concentration of nitroprusside was selected based on its previously-defined pharmacological activity (EC_{50}). The concentrations of the other agents in this test solution were determined based on the binding constants of the agents with their cognate receptors. Furthermore, all concentrations were adjusted based on a blood flow rate of 80 cc per minute in the distal aorta of the rabbit and a flow rate of 5 cc per minute in the solution delivery catheter. Three components were mixed in one cc or less DMSO, and then these components and the remaining three components were mixed to their final concentrations in normal saline. A control solution consisting of normal saline was utilized. The test solution or the control solution was infused at a rate of 5 cc per minute for 20 minutes. A brief pause in the infusion was necessary at the times blood pressure measurements were made, so each animal received about 95 cc of the solution in the 20 minute treatment period.

2. Animal Protocol

This protocol was approved by the Seattle Veteran Affairs Medical Center Committee on Animal Use, which is accredited by the American Association for Accreditation of Laboratory Animal Care. The iliac arteries of 3-4 kg male New Zealand white rabbits fed a 2% cholesterol rabbit chow for 3-4 weeks were studied.

The animals were sedated using intravenous xylazine (5 mg/kg) and ketamine (35 mg/kg) dosed to effect and a cutdown was performed in the ventral midline of the neck to isolate a carotid artery. The artery was ligated distally, an arteriotomy performed and a 5 French sheath was introduced into the descending aorta and positioned at the level of the renal arteries. Baseline blood pressure and heart rate were recorded. An angiogram of the distal aorta and bilateral iliac arteries was recorded on 35 mm cine film (frame rate 15 per second) using hand injection of iopamidol 76% (Squibb Diagnostics, Princeton, NJ) into the descending aorta.

For each angiogram, a calibration object was placed in the radiographic field of view to allow for correction for magnification when diameter measurements were made. Infusion of either the above described test solution or a saline control solution was started through the side arm of the 5 French sheath (and delivered to the distal aorta) at a rate of 5 cc per minute and continued for 20 minutes. At 5 minutes into the infusion, a second angiogram was performed using the previously described technique. Then a 1.25 mm or a 1.50 mm rotational atherectomy burr (Heart Technology/Boston Scientific Inc.) was advanced to the iliac arteries. The rotational atherectomy burr was advanced three times over a guide wire in each of the iliac arteries at a rotation rate of 150,000 to 200,000 RPM. In each iliac, the rotational atherectomy burr was advanced from the distal aorta to the mid portion of the iliac artery between the first and second deep femoral branches. The rotational atherectomy burr was rapidly removed and another angiogram was recorded on cine film at a mean of 8 minutes after the infusion was begun.

The infusion was continued until the 20 minute time point, and another angiogram (the fourth) was performed. Then the infusion was stopped. A total of about 95 cc of the control or test solution had been infused. At the 30 minute time point (15 minutes after the infusion was stopped), a final angiogram was recorded as before. Blood pressure and heart rate were recorded at the 15 and 30 minute time points immediately before the angiograms. After the final angiogram, the animal was euthanized with an overdose of the anesthetic agents administered intravenously.

3. Angiographic Analysis

The angiograms were recorded on 35 mm cine film at a frame rate of 15 per second. Angiograms were reviewed in random order without knowledge of treatment assignment. For analysis, the angiograms were projected from a Vanguard projector at a distance of 5.5 feet. The entire angiogram for each animal was reviewed to

identify the anatomy of the iliac arteries and to identify the sites of greatest spasm in the iliac arteries. A map of the iliac anatomy was prepared to assist in consistently identifying sites for measurement. Measurements were made on the 15 minute post rotational atherectomy angiogram first, then in random order on the remaining
5 angiograms from that animal. Measurements were made using an electronic hand-held caliper (Brown & Sharpe, Inc., N. Kingston, RI). Iliac artery diameters were measured at three locations: proximal to the first deep femoral branch of the iliac artery; at the site of most severe spasm (this occurred between the first and second deep femoral artery branches in all cases); and at a distal site (near or distal to the
10 origin of the second deep femoral artery branch of the iliac artery). Measurements were made at baseline (before test solution infusion was begun), 5 minutes into the infusion, immediately post rotational atherectomy (a mean of 8 minutes after the test solution was begun), at 20 minutes just after the infusion was stopped (this was 15 minutes after the rotational atherectomy was begun) and at 15 minutes after the
15 infusion was stopped (30 minutes after the rotational atherectomy was begun). The calibration object was measured in each angiogram.

The diameter measurements were then converted to area measurements by the formula:

$$\text{Area} = (\pi)(\text{Diameter}^2)/4.$$

20 For calculation of vasoconstriction, baseline values were used to represent the maximum area of the artery and percent vasoconstriction was calculated as:

$$\% \text{ Vasoconstriction} = \{(\text{Baseline area} - \text{Later time point area})/\text{Baseline area}\} \times 100.$$

4. Statistical Methods

25 All values are expressed as mean \pm 1 standard error of the mean. The time course of vasomotor response in control arteries was assessed using one way analysis of variance with correction for repeated measures. Post hoc comparison of data between specific time points was performed using the Scheffe test. Test solution treated arteries were compared to saline treated arteries at specified locations in the iliac arteries and at specified time points using multiple analysis of variance
30 (MANOVA). To compensate for the absence of a single *a priori* hypothesis, a p value < 0.01 was considered significant. Statistics were performed using Statistica for Windows, version 4.5, (Statsoft, Tulsa, OK).

5. Results

Eight arteries in 4 animals received saline solution and 13 arteries in seven animals received test solution. In each artery, regardless of the solution used, rotational atherectomy was performed with the rotating burr passing from the distal aorta to the mid-portion of the iliac artery. Thus, the proximal iliac artery segment and the segment designated as the site of maximal vasoconstriction were subjected to the rotating burr. The guide wire for the rotational atherectomy catheter passed through the distal segment, but the rotating burr of the rotational atherectomy catheter itself did not enter the distal segment.

Iliac artery diameters in saline treated arteries at the three specified segments are summarized in Table 25. In the proximal segment, there was no significant change in the diameter of the artery over the time course of the experiment ($p=0.88$, ANOVA). In the mid-iliac artery at the site of maximal vasoconstriction, there was a significant reduction in diameter with the largest reduction occurring at the 15 minute post-rotational atherectomy time point ($p<0.0001$, ANOVA comparing measurements at all 5 time points). The distal segment diameter did not significantly change over the time course of the experiment ($p=0.19$, ANOVA comparing all time points) although there was a trend towards a smaller diameter at the immediate post- and 15 minute post- rotational atherectomy time points.

20

Table 25

Iliac artery lumen diameters at specified time points in saline treated arteries.

Segment	Baseline N=8	5 Minutes into Infusion N=8	Immediate Post RA N=8	15 Minute after RA N=8	30 Minutes after RA N=8
Proximal ¹	2.40±.18	2.32±.14	2.32±0.13	2.38±.13	2.34±.07*
Mid ²	2.01±.08	1.84±.09	1.57±.15	1.24±.13	1.87±.06**
Distal ³	2.01±.10	1.86±.08	1.79±.08	1.81±.09	1.96±.06***

RA=rotational atherectomy

5 ¹ Proximal iliac artery measurement site, proximal to the first deep femoral branch

² Mid iliac artery at the site of maximal vasospasm

³ Distal iliac artery measurement site, near or distal to the second deep femoral branch

* p=0.88 by ANOVA comparing diameters in the proximal segment at the five time points.

***p=0.000007 by ANOVA comparing diameters at site of maximal vasospasm at the five time points.

*** p=0.19 by ANOVA comparing diameters in the distal segment at the five time points.

15

The diameters of iliac arteries treated with the test solution are shown in Table 26. Angiograms were not recorded in three of these arteries at the 5 minute post-initiation of the infusion time point and angiographic data were excluded from two arteries (one animal) at the 30 minute post-rotational atherectomy time point because the animal received an air embolus at the 15 minute angiogram that resulted in hemodynamic instability. Because there is a variable number of observations at the five time points, no ANOVA statistic was applied to this data. Still it is apparent that the magnitude of change in the diameter measurements within segments in the test solution treated arteries over the time course of the experiment is less than was seen in the saline treated arteries.

25

Table 26

Iliac artery lumen diameters at specified time points in Test Solution treated arteries.

Segment	Baseline N=13	5 Minutes into Infusion N=10	Immediate Post RA N=13	15 Minute after RA N=13	30 Minutes after RA N=11
Proximal ¹	2.28±.06	2.07±.07	2.22±.05	2.42±.06	2.39±.08
Mid ²	1.97±.06	1.79±.06	1.74±.04	1.95±.07	1.93±.08
Distal ³	2.00±.06	1.92±.04	1.90±.04	2.00±.06	2.01±.07

RA=rotational atherectomy

5 ¹ Proximal iliac artery measurement site, proximal to the first deep femoral branch

² Mid iliac artery at the site of maximal vasospasm

³ Distal iliac artery measurement site, near or distal to the second deep femoral branch

Because of the different number of observations at the various time points, ANOVA
10 was not performed to determine the statistical similarity/difference in diameters within specific segments.

The primary endpoint for this study was the comparison of the amounts of
vasoconstriction in saline treated and test solution treated arteries. Vasoconstriction
15 was based on arterial lumen areas derived from artery diameter measurements. Area values at the 5 minute, immediate post-rotational atherectomy and later time points were compared to the baseline area values to calculate the relative change in area. The results were termed “vasoconstriction” if the lumen area was smaller at the later time point than at baseline, and “vasodilatation” if the lumen area was larger at the
20 later time point compared to the baseline area (Tables 27 and 28). To facilitate statistical analysis with the largest number of observations possible in both treatment groups, the test solution and saline treated artery data were compared at the immediate post- and at the 15 minute postrotational atherectomy time points.

In the proximal segment (FIGURE 13), there was essentially no change in
25 lumen area with either treatment at the immediate post-rotational atherectomy time point, but there was some vasodilatation in this segment by the 15 minute post-

rotational atherectomy time point. Test solution did not alter the results of rotational atherectomy compared to saline treatment in this segment. In the mid-vessel (FIGURE 14) at the site of maximal vasoconstriction however, test solution significantly blunted the vasoconstriction, caused by rotational atherectomy in the saline treated arteries ($p=0.0004$, MANOVA corrected for repeated measures). In the distal segment (FIGURE 15), there was little vasoconstriction in the saline treated arteries and test solution did not significantly alter the response to rotational atherectomy.

Table 27

10 Amount of vasoconstriction (negative values) or vasodilatation (positive values) at specified time points in saline treated arteries.

Segment	5 Minutes into Infusion N=8	Immediate Post RA N=8	15 Minute after RA N=8	30 Minutes after RA N=8
Proximal ¹	-3%±.8%	-1%±10%	3%±8%	3%±13%
Mid ²	-14%±7%	-35%±10%	-58%±7%	-11%±.9%
Distal ³	-9%±.10%	-14%±.14%	-14%±10%	2%±.12%

¹ Proximal iliac artery measurement site, proximal to the first deep femoral branch

² Mid iliac artery at the site of maximal vasospasm

15 ³ Distal iliac artery measurement site, near or distal to the second deep femoral branch

Table 28

Amount of vasoconstriction (negative values) or vasodilatation (positive values) at specified time points in Test Solution treated arteries.

Segment	5 Minutes into Infusion N=10	Immediate Post RA N=13	15 Minute after RA N=13	30 Minutes after RA N=11
Proximal ¹	-17%±.5%	-4%±3%	14%±6%	7%±9%
Mid ²	-14%±5%	-20%±5%	0.3%±7%	-5%±.5%
Distal ³	-8%±.4%	-9%±.4%	1%±4%	3%±.6%

5 ¹ Proximal iliac artery measurement site, proximal to the first deep femoral branch

² Mid iliac artery at the site of maximal vasospasm

³ Distal iliac artery measurement site, near or distal to the second deep femoral branch

10 The hemodynamic response in the saline and test solution treated arteries is summarized in Table 29. Compared to saline treated animals, test solution treated animals sustained substantial hypotension and significant tachycardia during the solution infusion. By 15 minutes after completion of the infusion (or at the 30 minute postrotational atherectomy time point), test solution treated animals
15 showed some partial, but not complete, return of blood pressure towards baseline.

Table 29Blood pressure and heart rates during the protocol.

Group	Baseline (N)	5 Minute (N)	15 Minute (N)	30 Minute (N)
Systolic Blood Pressure				
Saline	83±9 (4)	93±6 (3)	92±11 (4)	83±10 (4)*
Test Solution	92±5 (7)	35±5 (7)	35±5 (7)	46±5 (7)**
Heart Rate				
Saline	202±16 (3)	204±3 (3)	198±22 (3)	193±29 (3)*
Test Solution	187±111 (7)	246±11 (7)	240±5 (7)	247±16 (7)**

* There was no significant change in systolic blood pressure or heart rate in this group (p=0.37 for systolic blood pressure and p=0.94 for heart rate, ANOVA).

** There was a highly significant change in systolic blood pressure and heart rate in this group (p<0.0001 for systolic blood pressure and p=0.002 for heart rate, ANOVA).

6. Summary of Study

10 1. Rotational atherectomy in hypercholesterolemic New Zealand white rabbits results in prominent vasospasm in the mid-portion of iliac arteries subjected to the rotating burr. The vasospasm is most apparent 15 minutes after rotational atherectomy treatment and has almost completely resolved without pharmacologic intervention by 30 minutes after rotational atherectomy.

15 2. Under the conditions of rotational atherectomy treatment studied in this protocol, test solution treatment in accordance with the present invention almost completely abolishes the vasospasm seen after the mid-iliac artery is subjected to the rotating burr.

20 3. Treatment with test solution of the present invention given the concentration of components used in this protocol results in profound hypotension

during the infusion of the solution. The attenuation of vasospasm after rotational atherectomy by test solution occurred in the presence of severe hypotension.

While the preferred embodiment of the invention has been illustrated and described, it will be appreciated that various changes to the disclosed solutions and methods can be made therein without departing from the spirit and scope of the invention. For example, alternate pain inhibitors and anti-inflammation and anti-spasm and anti-restenosis agents may be discovered that may augment or replace the disclosed agents in accordance with the disclosure contained herein. It is therefore intended that the scope of letters patent granted hereon be limited only by the definitions of the appended claims.

The embodiments of the invention in which an exclusive property or privilege is claimed are defined as follows:

1. A method of preemptively inhibiting pain and inflammation at a wound during a surgical procedure, comprising delivering to a wound during a surgical procedure a solution comprising at least one cyclooxygenase-2 (COX-2) inhibitor, wherein the solution is applied locally and perioperatively to the surgical site.

2. The method of Claim 1, wherein the COX-2 inhibitor is selected from the group consisting of celecoxib, meloxicam, nimesulide, nimesulide, diclofenac, flosulide, N-[2-(cyclohexyloxy)-4-nitrophenyl]-methanesulfonamide, 1-[(4-methylsulfonyl)phenyl]-3-trifluoromethyl-5-[(4-fluoro)phenyl]pyrazole, DuP 697, SC-58451, RS-57067, SC-57666 and L-745,337.

3. The method of Claim 1, wherein the solution further comprises at least one additional pain/inflammation inhibitory agent selected to act on a different molecular target than the COX-2 inhibitor.

4. The method of Claim 1, comprising continuously applying the solution to the wound.

5. The method of Claim 4, comprising continuously irrigating the wound with the solution.

6. The method of Claim 1, wherein the solution is applied by irrigation of the wound.

7. The method of Claim 1, wherein the solution is locally applied to the wound in the absence of metabolic transformation.

8. The method of Claim 1, wherein the perioperative application of the solution comprises intraprocedural application together with preprocedural or postprocedural application of the solution.

9. The method of Claim 8, wherein the perioperative application of the solution comprises preprocedural, intraprocedural and postprocedural application of the solution.

10. The method of Claim 8, wherein the solution is continuously applied to the wound.

11. The method of Claim 1, wherein each of the COX-2 inhibitor in the solution is delivered locally at a concentration of no greater than 100,000 nanomolar.

12. The method of Claim 3, wherein each of the additional agents in the solution is delivered locally at a concentration of no greater than 100,000 nanomolar.

13. The method of Claim 1, wherein each of the plurality of agents in the solution applied is included at a concentration that is sufficient to provide a predetermined level of pain/inflammation inhibitory effect at the wound when locally applied in the absence of metabolic transformation, and that is less than a concentration which would be required to provide the same predetermined level of inhibitory effect at the wound if applied in a manner which would entail metabolic transformation of the agents.

14. The method of Claim 3, wherein the at least one pain/inflammation inhibitory agent is selected from the group consisting of: serotonin receptor antagonists; serotonin receptor agonists; histamine receptor antagonists; bradykinin receptor antagonists; kallikrein inhibitors; tachykinin receptor antagonists including neurokinin₁ receptor subtype antagonists and neurokinin₂ receptor subtype antagonists; calcitonin gene-related peptide receptor antagonists; interleukin receptor antagonists; phospholipase inhibitors including PLA₂ isoform inhibitors and PLC_γ isoform inhibitors; cyclooxygenase inhibitors; lipooxygenase inhibitors; prostanoid receptor antagonists including eicosanoid EP-1 receptor subtype antagonists and eicosanoid EP-4 receptor subtype antagonists and thromboxane receptor subtype antagonists; leukotriene receptor antagonists including leukotriene B₄ receptor subtype antagonists and leukotriene D₄ receptor subtype antagonists; opioid receptor agonists including μ-opioid receptor subtype agonists, δ-opioid receptor subtype agonists, and κ-opioid receptor subtype agonists; purinoceptor agonists and antagonists including P_{2Y} receptor agonists and P_{2X} receptor antagonists; and ATP-sensitive potassium channel openers.

15. The method of Claim 14, wherein the selected pain/inflammation inhibitory agents are delivered locally at a concentration of: 0.1 to 10,000 nanomolar for serotonin receptor antagonists; 0.1 to 2,000 nanomolar for serotonin receptor agonists; 0.01 to 1,000 nanomolar for histamine receptor antagonists; 0.1 to 10,000 nanomolar for bradykinin receptor antagonists; 0.1 to 1,000 nanomolar for kallikrein inhibitors; 0.1 to 10,000 nanomolar for neurokinin₁ receptor subtype antagonists; 1.0 to 10,000 nanomolar for neurokinin₂ receptor subtype antagonists; 1 to 1,000 nanomolar for calcitonin gene-related peptide receptor antagonists; 1 to 1,000 nanomolar for interleukin receptor antagonists; 100 to 100,000 nanomolar for PLA₂ isoform inhibitors; 100 to 200,000 nanomolar for cyclooxygenase inhibitors; 100 to 10,000 nanomolar for lipooxygenase inhibitors; 100 to 10,000 nanomolar for eicosanoid EP-1 receptor subtype antagonists; 100 to 10,000 nanomolar for leukotriene B₄ receptor subtype antagonists; 0.1 to 500 nanomolar for μ -opioid receptor subtype agonists; 0.1 to 500 nanomolar for δ -opioid receptor subtype agonists; 0.1 to 500 nanomolar for κ -opioid receptor subtype agonists; 100 to 100,000 nanomolar for purinoceptor antagonists; and 0.1 to 10,000 nanomolar for ATP-sensitive potassium channel openers.

16. A solution for use in the preemptive inhibition of pain and inflammation at a wound during a surgical procedure, comprising at least one COX-2 inhibitor in a liquid carrier, the concentration of said agonist within the solution being the concentration of that agent which is desired to be delivered locally, in the absence of metabolic transformation, to a wound in order to achieve a predetermined level of inhibitory effect at the wound.

17. The solution of Claim 16, wherein the COX-2 inhibitor is selected from the group consisting of celecoxib, meloxicam, nimesulide, nimesulide, diclofenac, flosulide, N-[2-(cyclohexyloxy)-4-nitrophenyl]-methanesulfonamide, 1-[(4-methylsulfonyl)phenyl]-3-trifluoromethyl-5-[(4-fluoro)phenyl]pyrazole, DuP 697, SC-58451, RS-57067, SC-57666 and L-745,337.

18. The solution of Claim 16, which further comprises at least one additional pain/inflammation inhibitory agent selected to act on a different molecular target than the COX-2 inhibitor.

19. The solution of Claim 18, wherein the COX-2 inhibitor and each of the additional agents in the solution is included at a concentration of no greater than

100,000 nanomolar, adjusted for dilution in the absence of metabolic transformation, at an intended local delivery site.

20. The solution of Claim 19, wherein each of the plurality of agents in the solution is included at a concentration that is less than a concentration which would be required to provide the same predetermined level of inhibitory effect at the wound if the solution was applied in a manner which would entail metabolic transformation of the agents.

21. The solution of Claim 18, wherein the at least one additional pain/inflammation inhibitory agents are selected from the group consisting of: serotonin receptor antagonists; serotonin receptor agonists; histamine receptor antagonists; bradykinin receptor antagonists; kallikrein inhibitors; tachykinin receptor antagonists including neurokinin₁ receptor subtype antagonists and neurokinin₂ receptor subtype antagonists; calcitonin gene-related peptide receptor antagonists; interleukin receptor antagonists; phospholipase inhibitors including PLA₂ isoform inhibitors and PLC_γ isoform inhibitors; cyclooxygenase inhibitors; lipooxygenase inhibitors; prostanoid receptor antagonists including eicosanoid EP-1 receptor subtype antagonists and eicosanoid EP-4 receptor subtype antagonists and thromboxane receptor subtype antagonists; leukotriene receptor antagonists including leukotriene B₄ receptor subtype antagonists and leukotriene D₄ receptor subtype antagonists; opioid receptor agonists including μ-opioid receptor subtype agonists, δ-opioid receptor subtype agonists, and κ-opioid receptor subtype agonists; purinoceptor agonists and antagonists including P_{2Y} receptor agonists and P_{2X} receptor antagonists; and ATP-sensitive potassium channel openers.

22. The solution of Claim 18, wherein the additional pain/inflammation inhibitory agents are included at a concentration of: 0.1 to 10,000 nanomolar for serotonin receptor antagonists; 0.1 to 2,000 nanomolar for serotonin receptor agonists; 0.01 to 1,000 nanomolar for histamine receptor antagonists; 0.1 to 10,000 nanomolar for bradykinin receptor antagonists; 0.1 to 1,000 nanomolar for kallikrein inhibitors; 0.1 to 10,000 nanomolar for neurokinin₁ receptor subtype antagonists; 1.0 to 10,000 nanomolar for neurokinin₂ receptor subtype antagonists; 1 to 1,000 nanomolar for calcitonin gene-related peptide receptor antagonists; 1 to 1,000 nanomolar for interleukin receptor antagonists; 100 to 100,000 nanomolar for PLA₂ isoform inhibitors; 100 to 200,000 nanomolar for cyclooxygenase inhibitors; 100 to 10,000 nanomolar for lipooxygenase inhibitors; 100 to 10,000 nanomolar for

eicosanoid EP-1 receptor subtype antagonists; 100 to 10,000 nanomolar for leukotriene B₄ receptor subtype antagonists; 0.1 to 500 nanomolar for μ -opioid receptor subtype agonists; 0.1 to 500 nanomolar for δ -opioid receptor subtype agonists; 0.1 to 500 nanomolar for κ -opioid receptor subtype agonists; 100 to 100,000 nanomolar for purinoceptor antagonists; and 0.1 to 10,000 nanomolar for ATP-sensitive potassium channel openers.

Fig. 1 VASCULAR CELL MOLECULAR TARGETS & SIGNALING INFORMATION

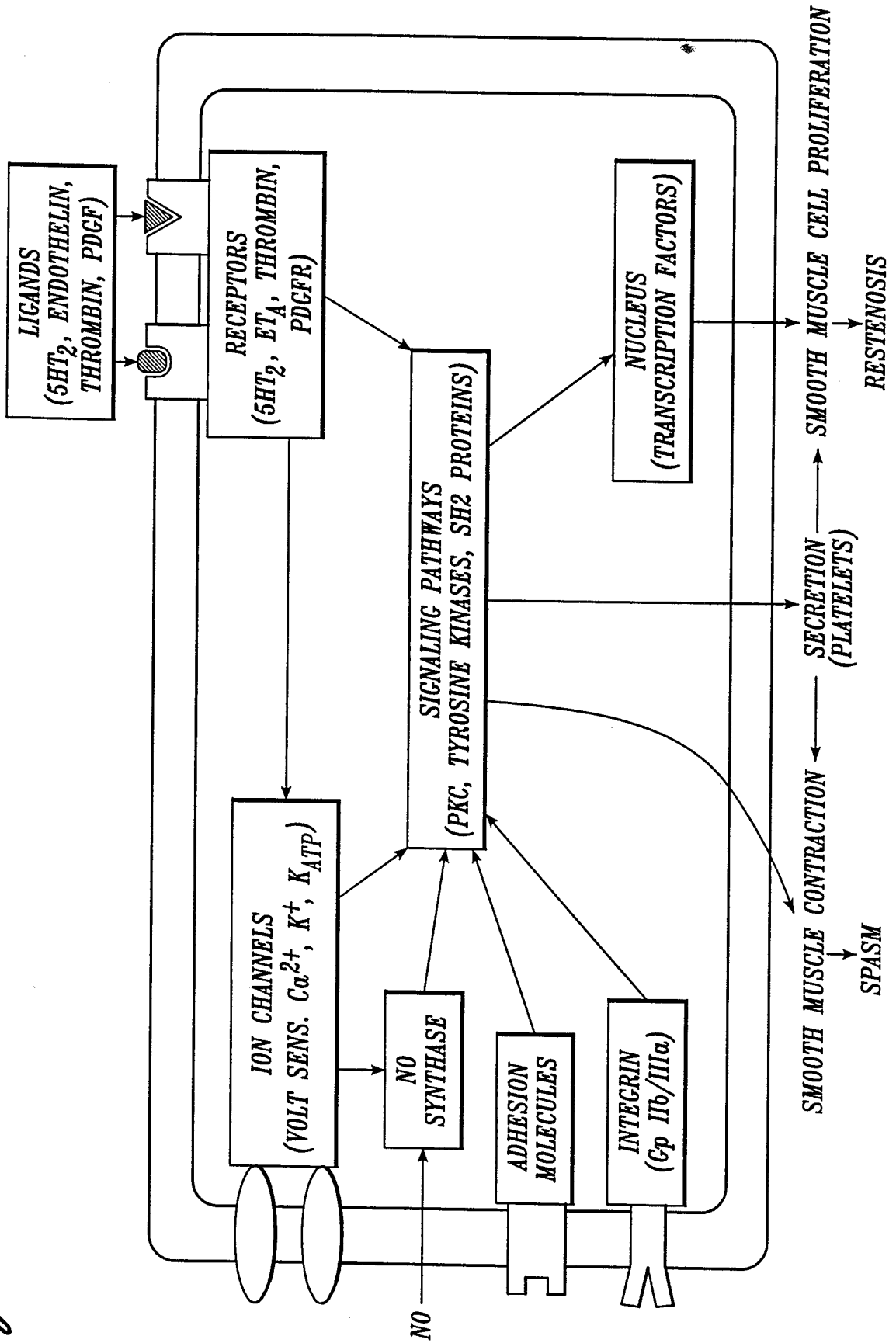

2/12

Fig. 2 DETAILED SIGNALING PATHWAYS IN A VASCULAR SMOOTH MUSCLE CELL

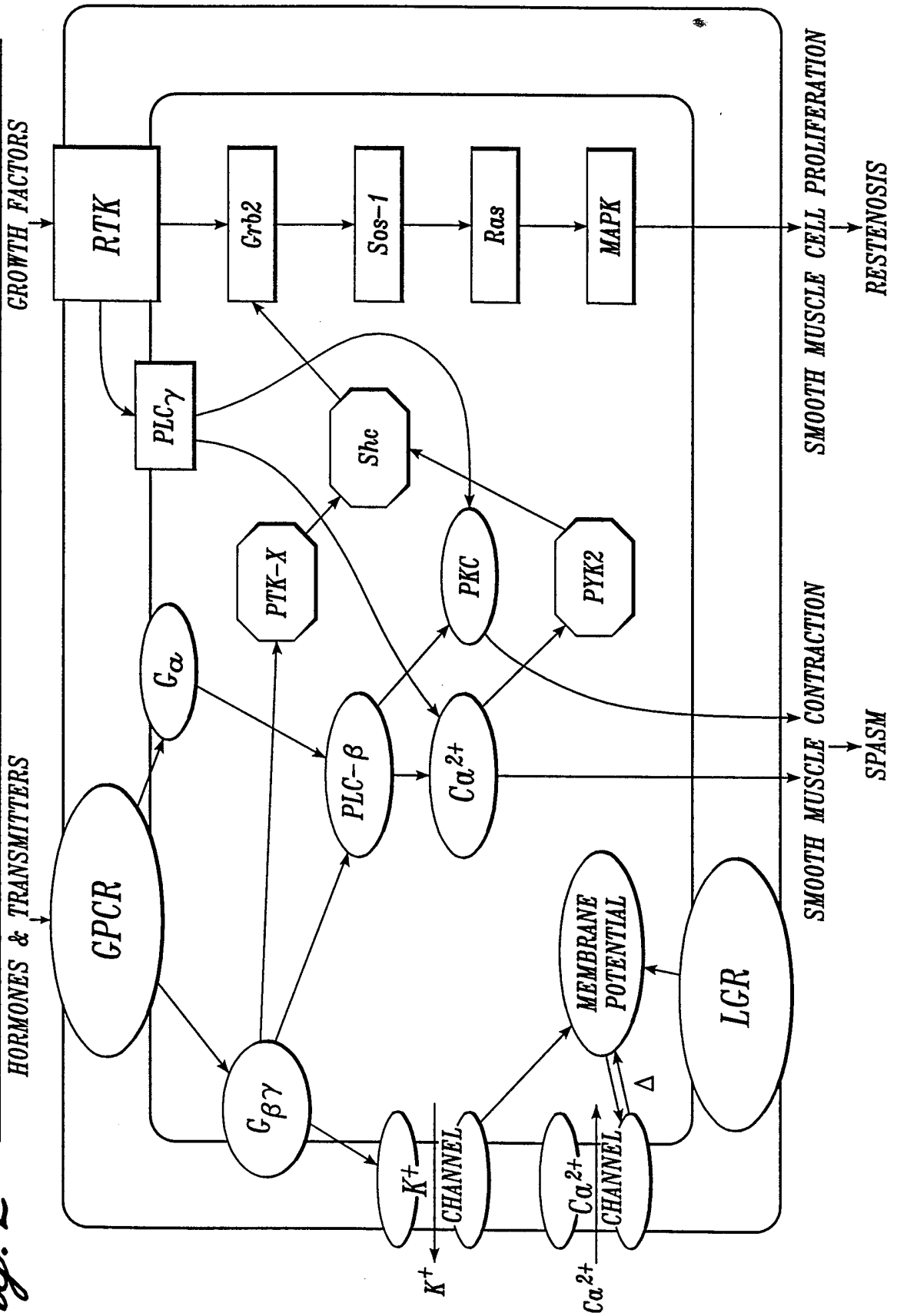

3/12

MOLECULAR SITES OF DRUG ACTION IN PREFERRED ARTHROSCOPIC SOLUTION

Fig. 3

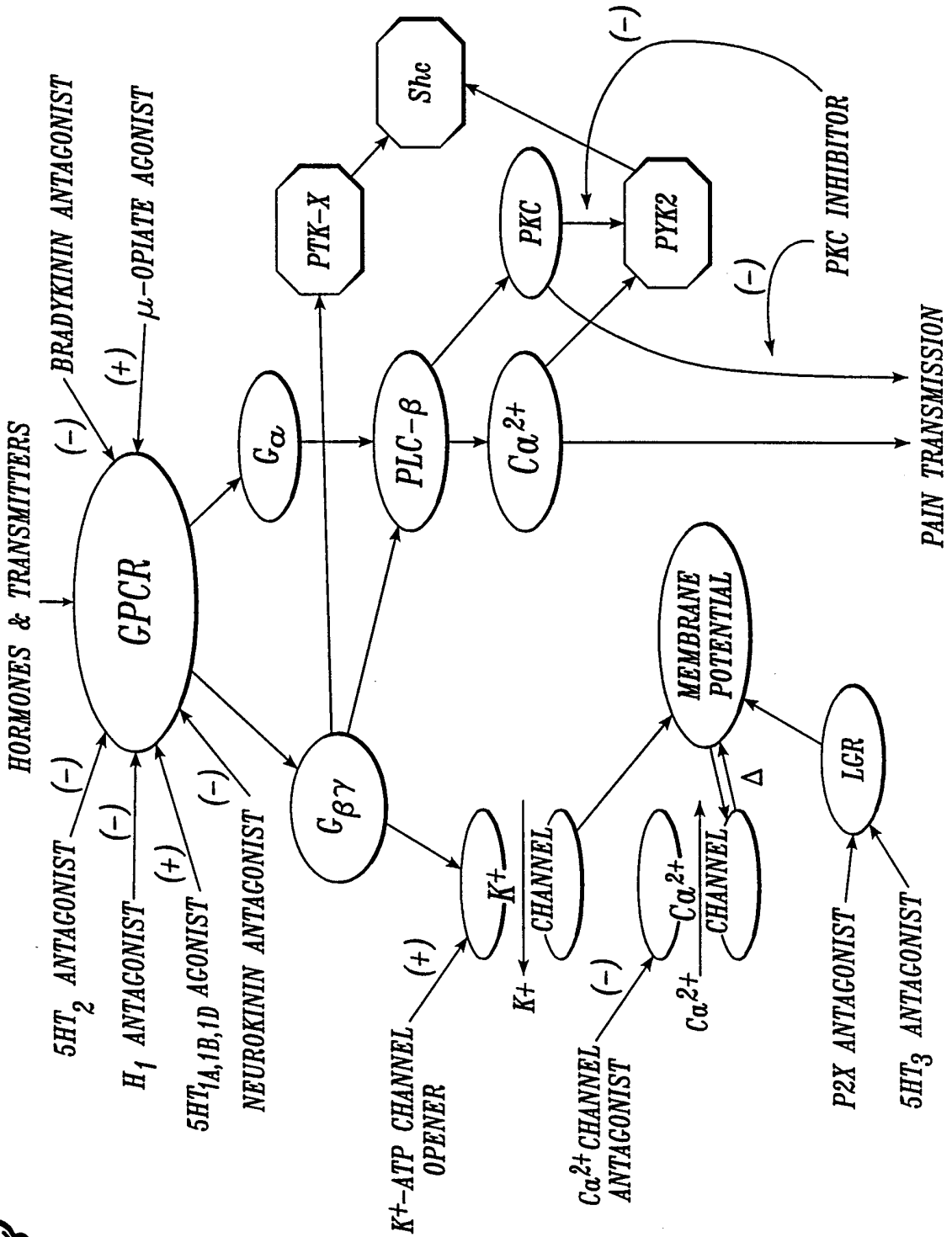

MOLECULAR SITES OF DRUG ACTION IN PREFERRED CARDIOVASCULAR & GENERAL VASCULAR SOLUTION - I/II

HORMONES & TRANSMITTERS

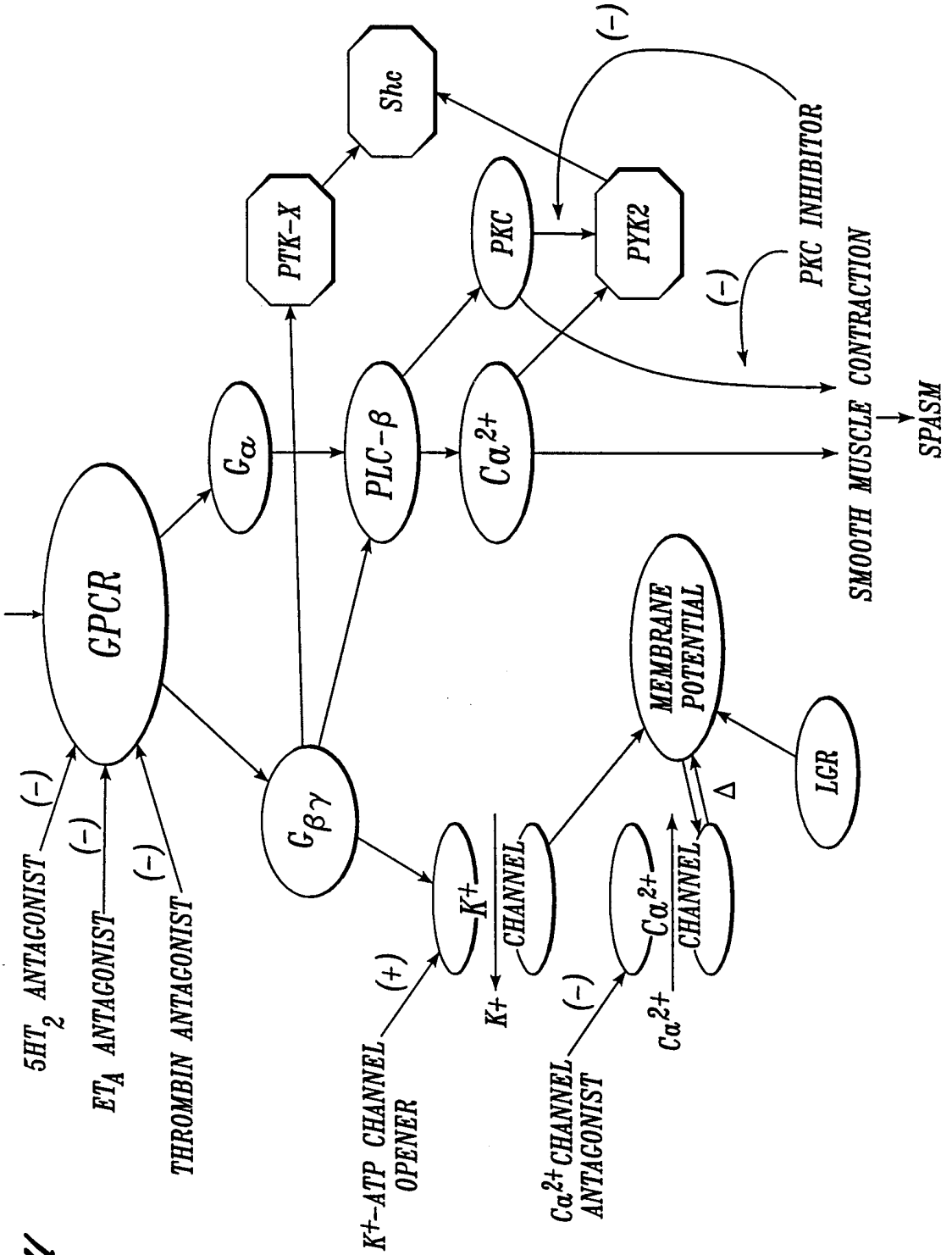

Fig. 4

5/12

MOLECULAR SITES OF DRUG ACTION IN PREFERRED CARDIOVASCULAR & GENERAL VASCULAR SOLUTION - II/II

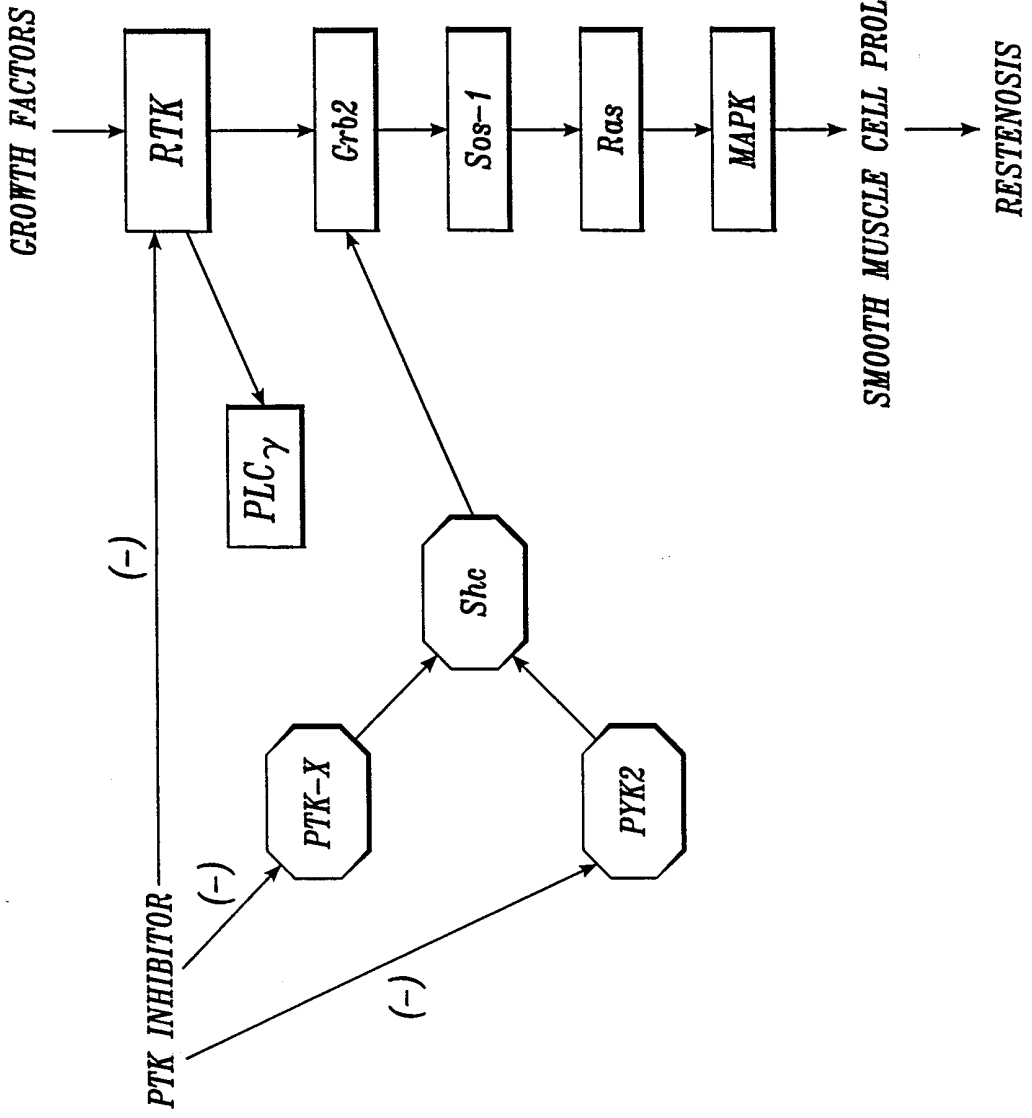
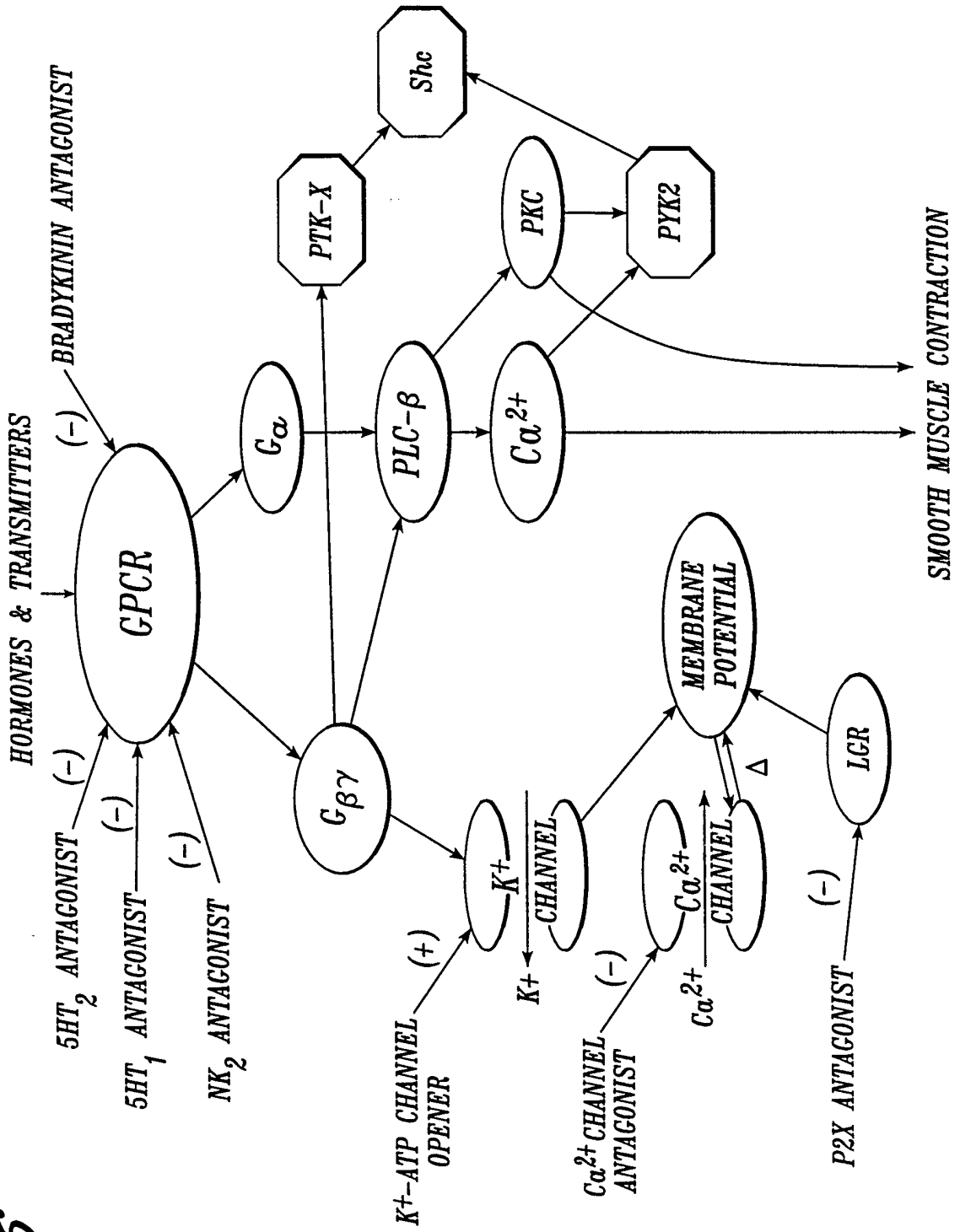

Fig. 5

6/12

MOLECULAR SITES OF DRUG ACTION IN PREFERRED UROLOGIC SOLUTION

Fig. 6



7/12

MOLECULAR SITES OF DRUG ACTION IN PREFERRED GENERAL SURGICAL WOUND SOLUTION

Fig. 7

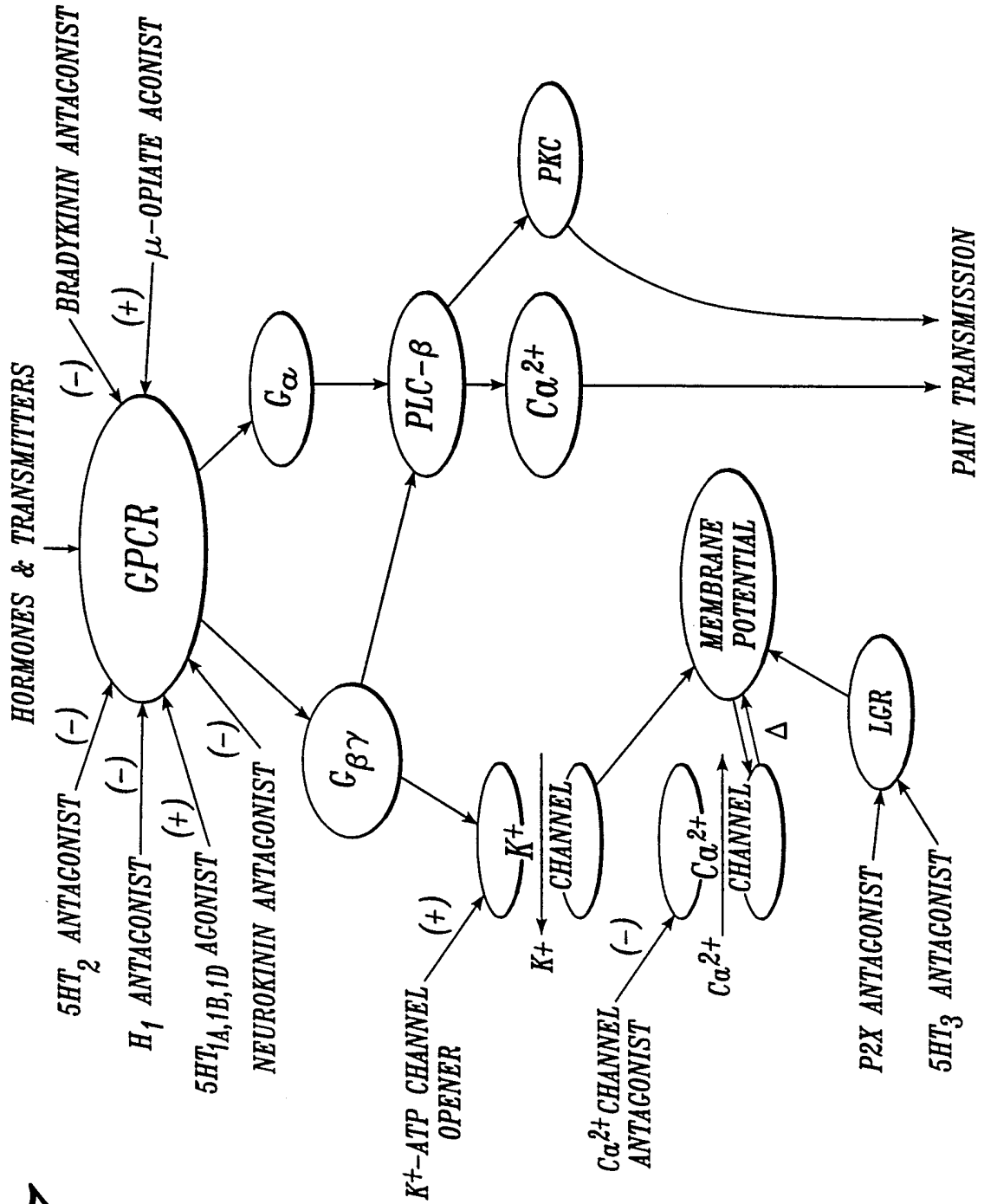

8/12

MECHANISM OF ACTION OF NO DONOR DRUGS ON A VASCULAR SMOOTH MUSCLE CELL

Fig. 8

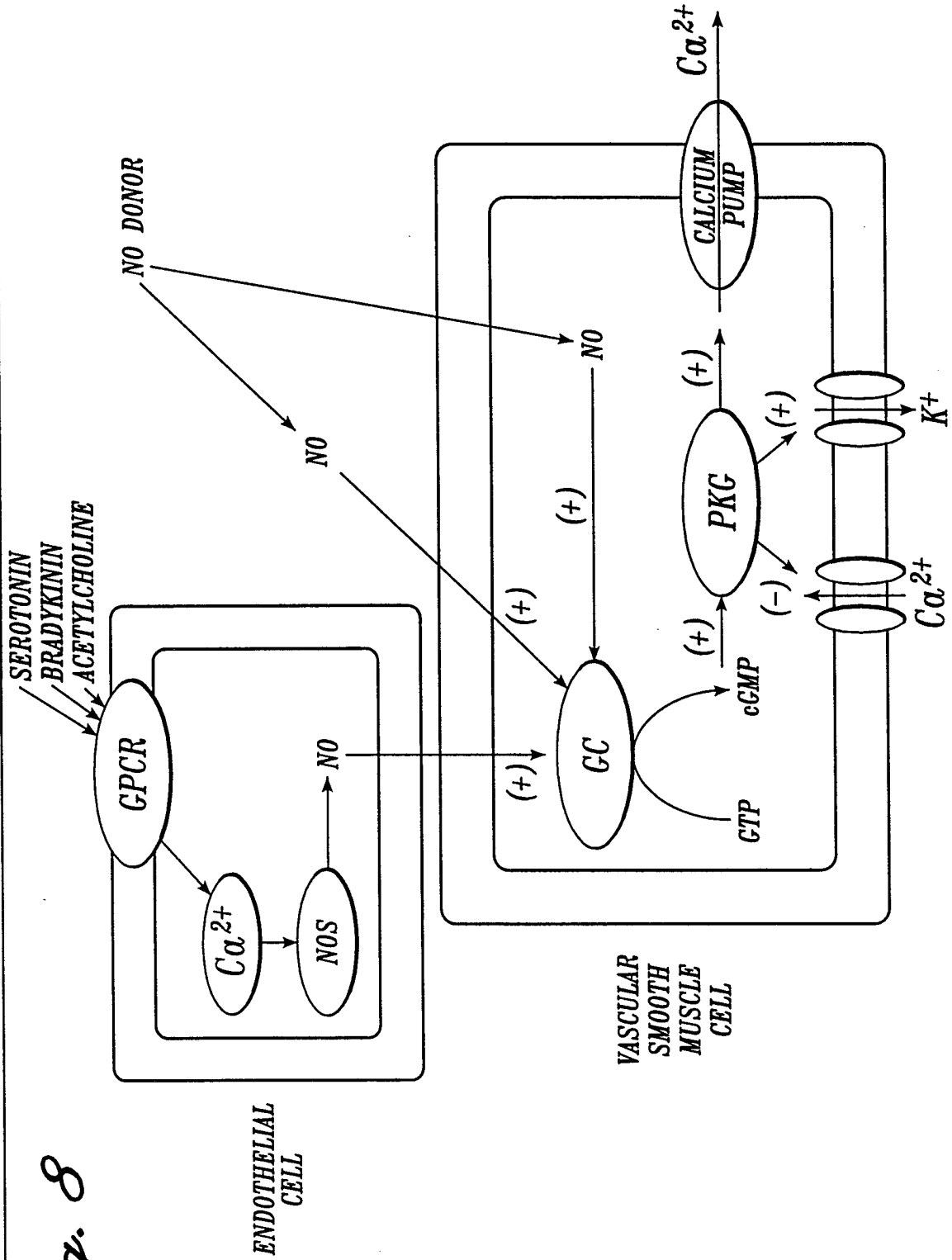

9/12

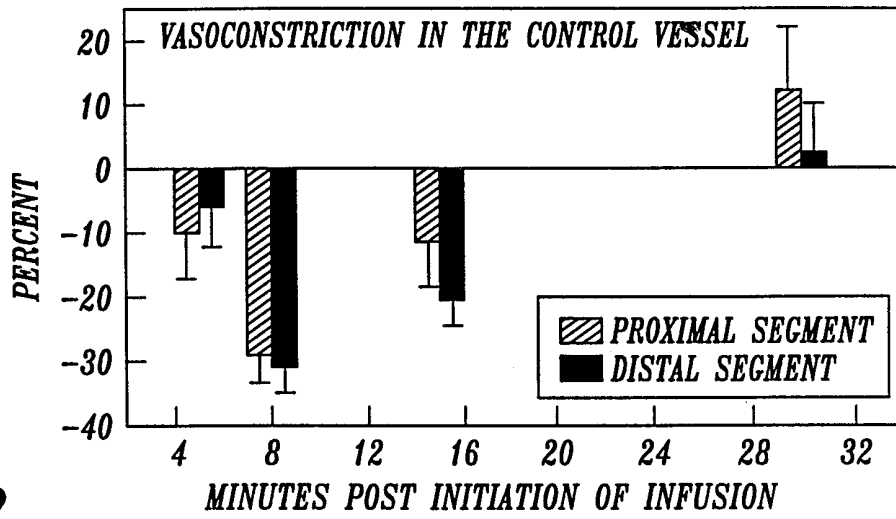

Fig. 9.

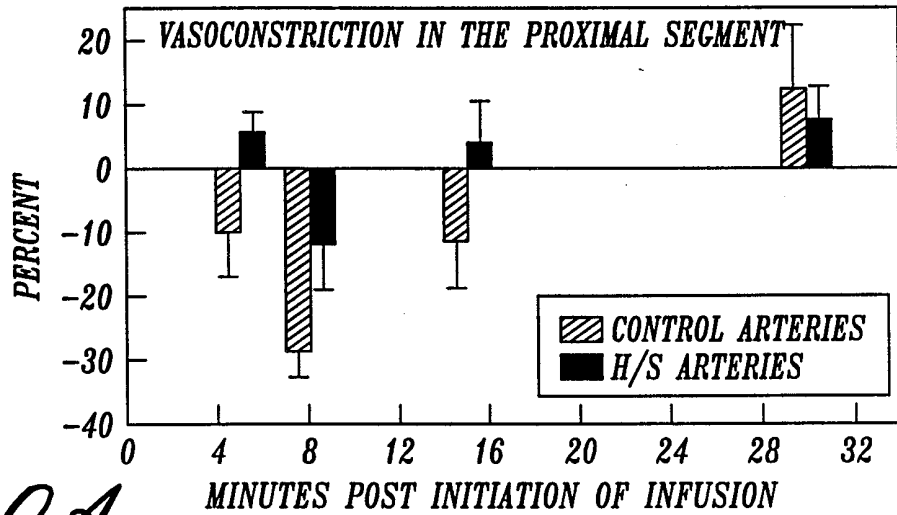

Fig. 10A.

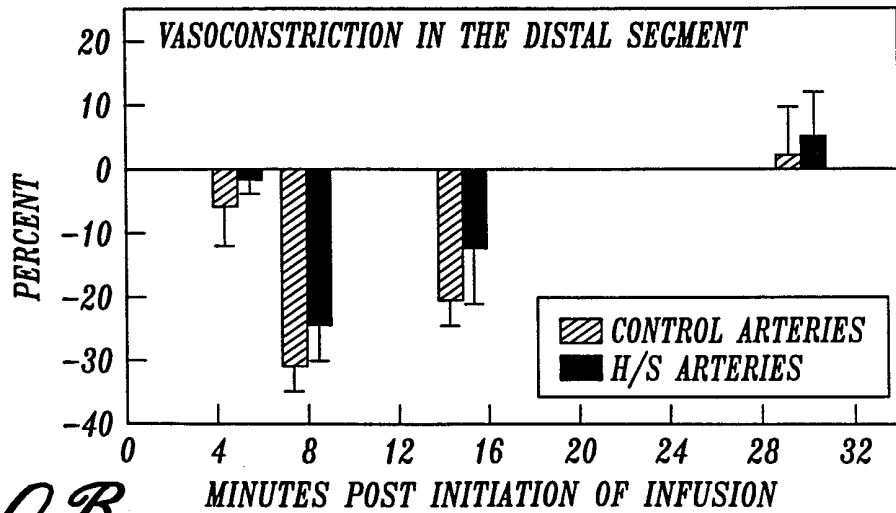
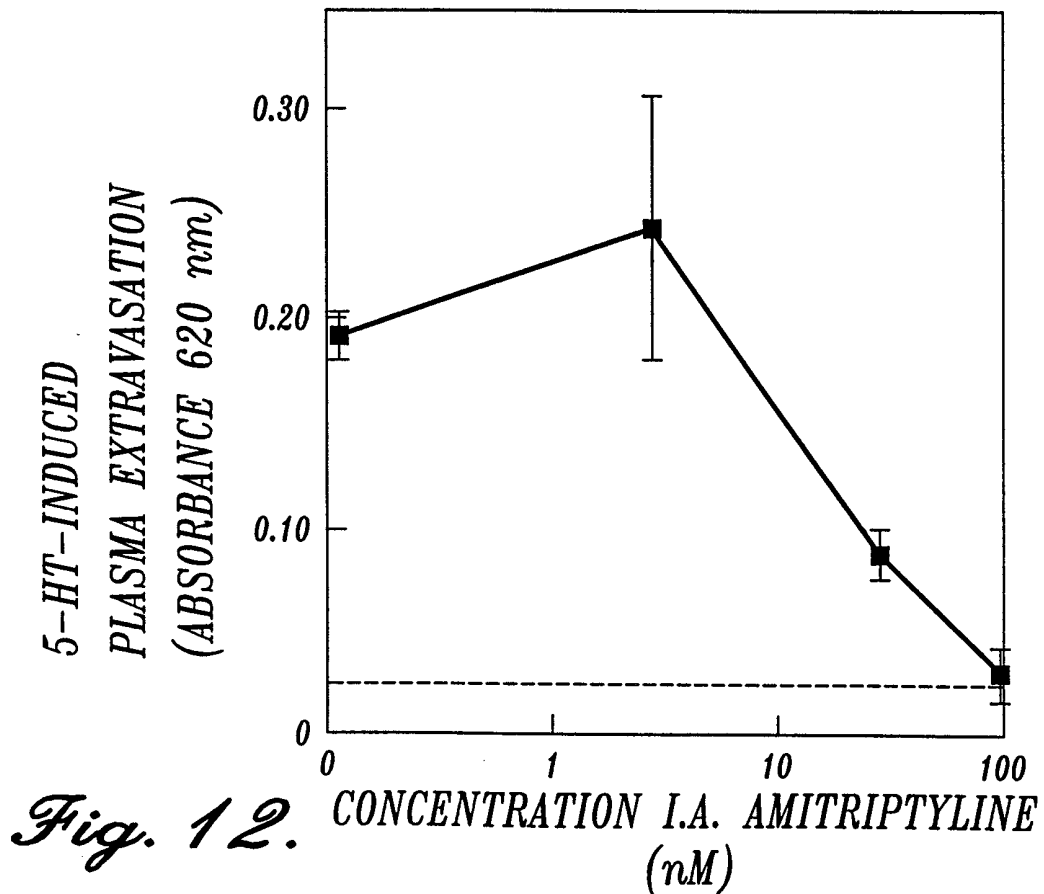
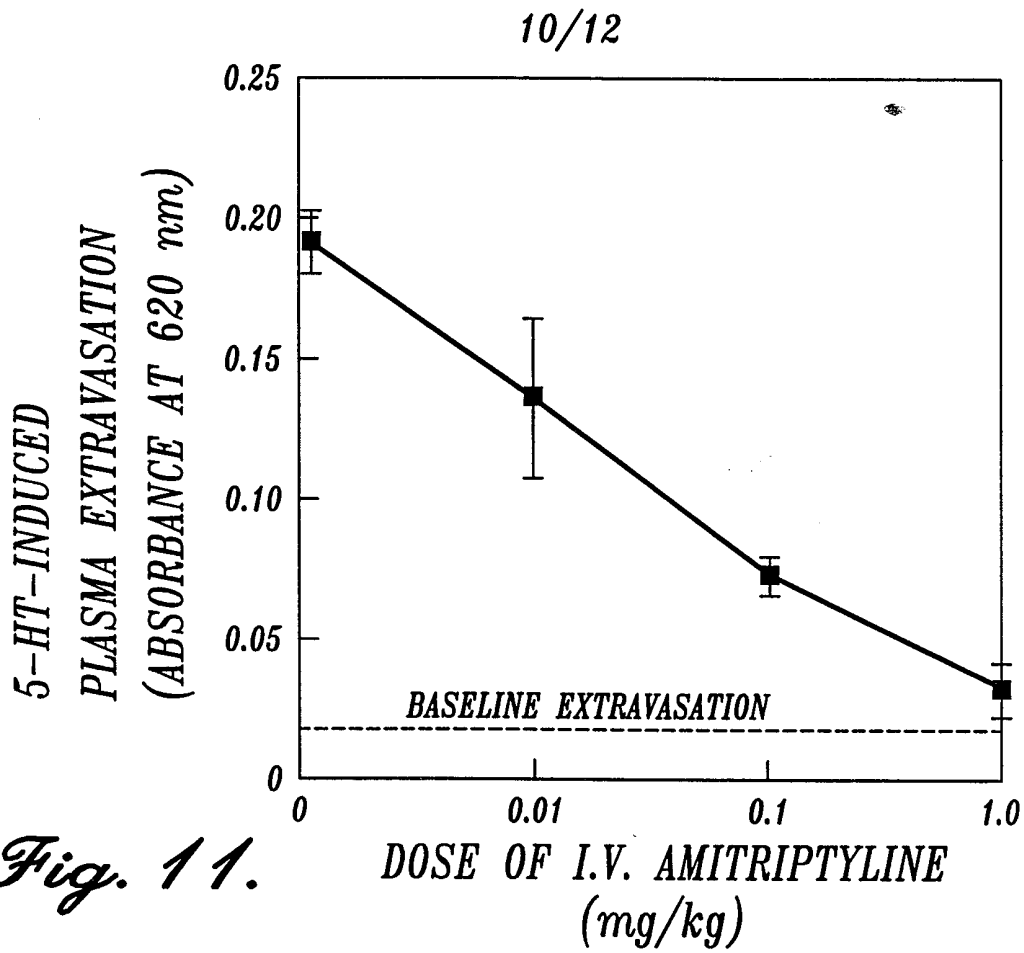

Fig. 10B.



11/12

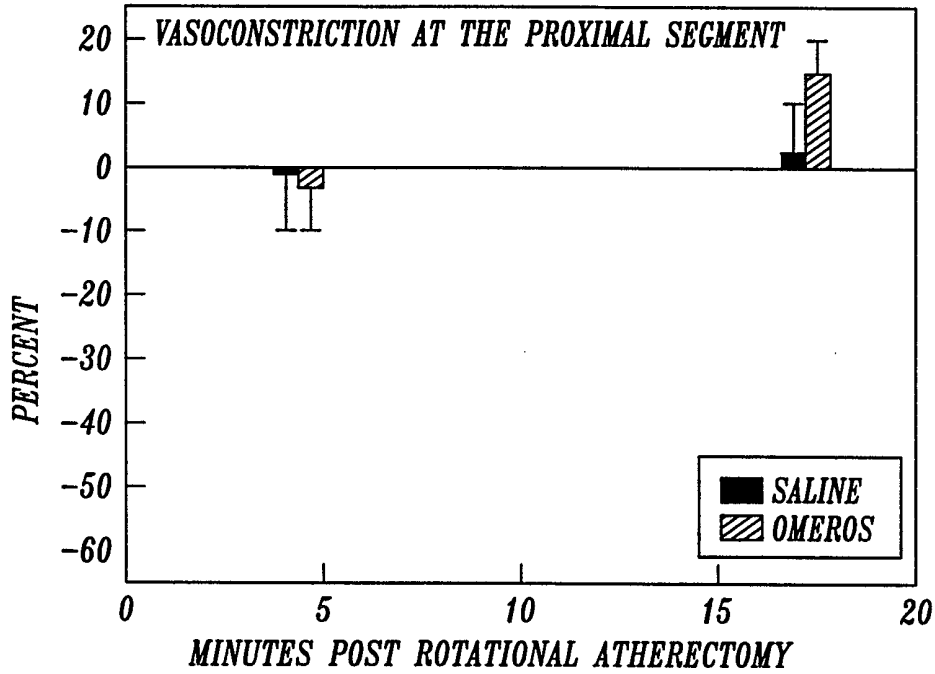

Fig. 13.

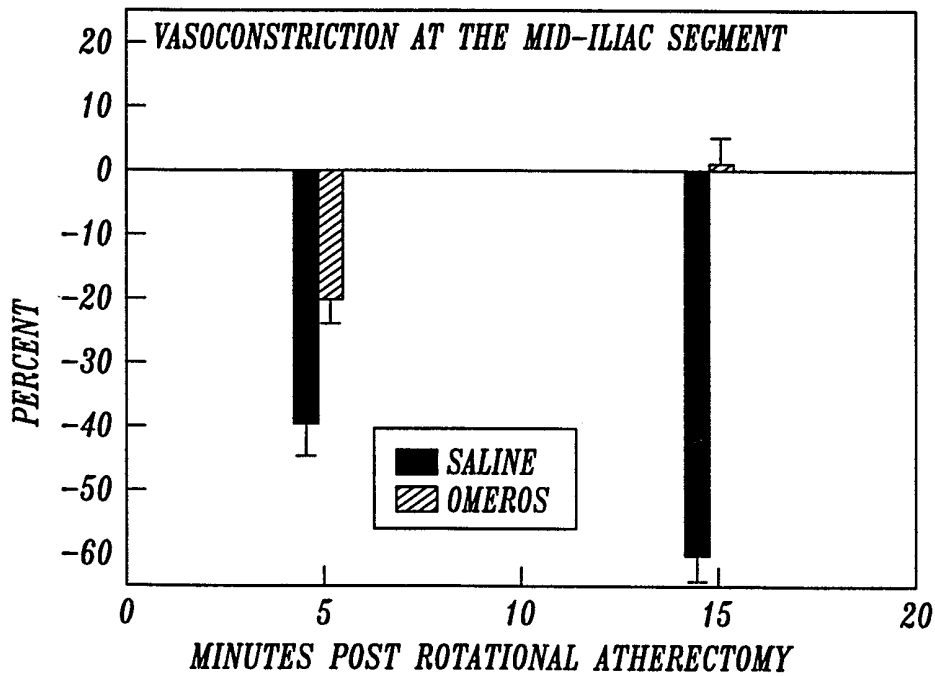

Fig. 14.

12/12

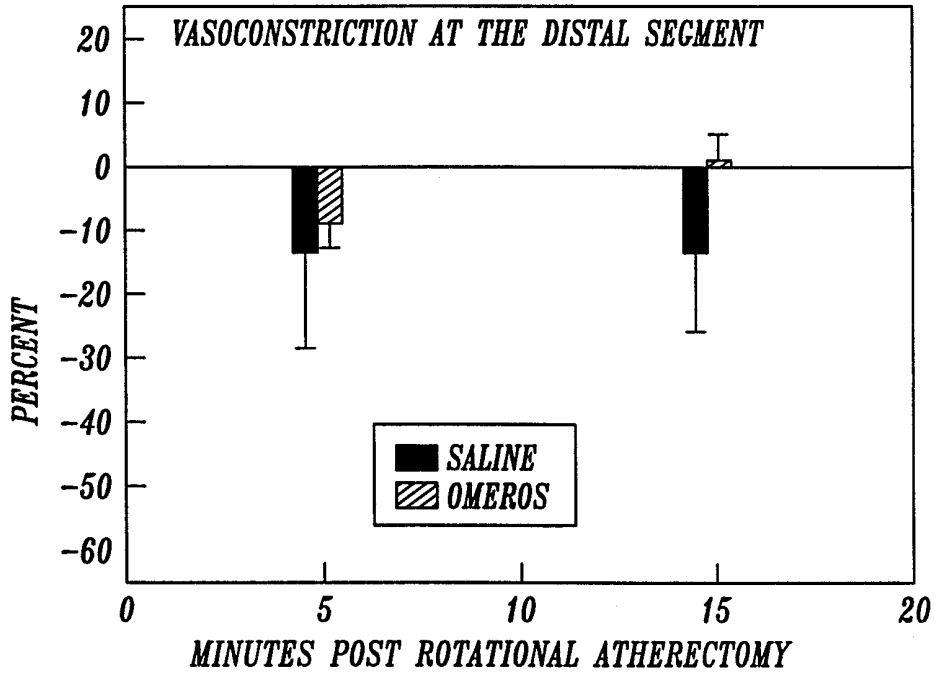

Fig. 15.