

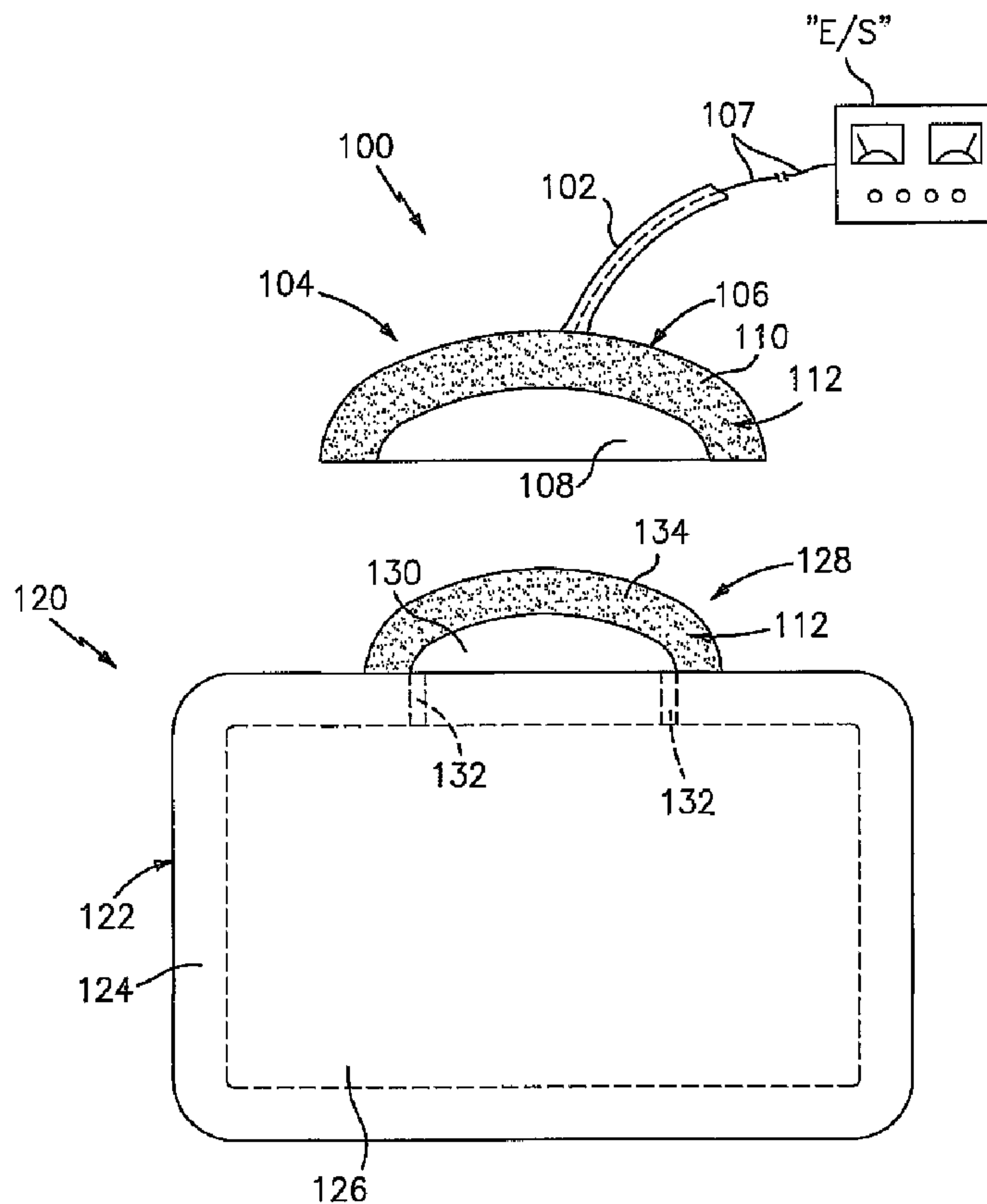

(86) Date de dépôt PCT/PCT Filing Date: 2002/05/31
 (87) Date publication PCT/PCT Publication Date: 2002/12/12
 (45) Date de délivrance/Issue Date: 2011/01/11
 (85) Entrée phase nationale/National Entry: 2003/11/24
 (86) N° demande PCT/PCT Application No.: US 2002/017360
 (87) N° publication PCT/PCT Publication No.: 2002/099442
 (30) Priorité/Priority: 2001/06/01 (US60/295,176)

(51) Cl.Int./Int.Cl. *H01R 4/04* (2006.01),
A61B 18/16 (2006.01), *A61N 1/04* (2006.01),
H01R 11/22 (2006.01), *H01R 13/62* (2006.01),
A61B 17/00 (2006.01), *H01R 4/26* (2006.01)
 (72) Inventeurs/Inventors:
 EHR, CHRISTOPHER J., US;
 SCHOENMAN, ARTHUR, US
 (73) Propriétaire/Owner:
 SHERWOOD SERVICES AG, CH
 (74) Agent: MCFADDEN, FINCHAM

(54) Titre : CONNECTEUR POUR CABLE D'ELECTRODE DE RETOUR
 (54) Title: RETURN PAD CABLE CONNECTOR



(57) Abrégé/Abstract:

A return pad cable connector, in accordance with the present disclosure, for use with a disposable return pad, includes a cord having a conductive wire disposed therethrough which conductive wire interconnects the return pad cable connector to an

(57) **Abrégé(suite)/Abstract(continued):**

electrosurgical energy source. The return pad further includes a connector operatively coupled to the cord, the connector having a conductive surface which is selectively engageable with a corresponding conductive surface disposed on the return pad, the conductive surface of the connector including a conductive adhesive disposed thereon and a non-conductive adhesive disposed above the periphery of the conductive surface of the connector for engagement with a corresponding non-conductive adhesive disposed above the periphery of the conductive surface of the return pad. The connector can include a magnet for magnetically coupling the connector to the conductive surface disposed on the return pad.

(12) INTERNATIONAL APPLICATION PUBLISHED UNDER THE PATENT COOPERATION TREATY (PCT)

(19) World Intellectual Property Organization
International Bureau



(43) International Publication Date
12 December 2002 (12.12.2002)

PCT

(10) International Publication Number
WO 02/099442 A2

- (51) International Patent Classification⁷: **G01R**
- (21) International Application Number: PCT/US02/17360
- (22) International Filing Date: 31 May 2002 (31.05.2002)
- (25) Filing Language: English
- (26) Publication Language: English
- (30) Priority Data:
60/295,176 1 June 2001 (01.06.2001) US
- (71) Applicant (for all designated States except US): **SHERWOOD SERVICES AG** [CH/CH]; Schwertstrasse 9, CH-8200 Schaffhausen (CH).
- (72) Inventors; and
- (75) Inventors/Applicants (for US only): **EHR, Christopher, J.** [US/US]; 3956 Hawthorne Circle, Longmont, CO 80503 (US). **SHOENMAN, Arthur** [US/US]; 2244 Vivian Street, Longmont, CO 80503 (US).
- (74) Agent: **DENNINGER, Douglas, E.**; Tyco Healthcare Group LP, 150 Glover Avenue, Norwalk, CT 06856 (US).
- (81) Designated States (*national*): AE, AG, AL, AM, AT (utility model), AU, AZ, BA, BB, BG, BR, BY, BZ, CA, CH, CN, CO, CR, CU, CZ (utility model), DE (utility model), DK (utility model), DM, DZ, EC, EE (utility model), ES, FI (utility model), GB, GD, GE, GH, GM, HR, HU, ID, IL, IN, IS, JP, KE, KG, KP, KR, KZ, LC, LK, LR, LS, LT, LU, LV, MA, MD, MG, MK, MN, MW, MX, MZ, NO, NZ, OM, PH, PL, PT, RO, RU, SD, SE, SG, SI, SK (utility model), SL, TJ, TM, TN, TR, TT, TZ, UA, UG, US, UZ, VN, YU, ZA, ZM, ZW.
- (84) Designated States (*regional*): ARIPO patent (GH, GM, KE, LS, MW, MZ, SD, SL, SZ, TZ, UG, ZM, ZW), Eurasian patent (AM, AZ, BY, KG, KZ, MD, RU, TJ, TM), European patent (AT, BE, CH, CY, DE, DK, ES, FI, FR, GB, GR, IE, IT, LU, MC, NL, PT, SE, TR), OAPI patent (BF, BJ, CF, CG, CI, CM, GA, GN, GQ, GW, ML, MR, NE, SN, TD, TG).
- Published:**
— without international search report and to be republished upon receipt of that report
- For two-letter codes and other abbreviations, refer to the "Guidance Notes on Codes and Abbreviations" appearing at the beginning of each regular issue of the PCT Gazette.*

(54) Title: RETURN PAD CABLE CONNECTOR

(57) Abstract: A return pad cable connector, in accordance with the present disclosure, for use with a disposable return pad, includes a cord having a conductive wire disposed therethrough which conductive wire interconnects the return pad cable connector to an electrosurgical energy source. The return pad further includes a connector operatively coupled to the cord, the connector having a conductive surface which is selectively engageable with a corresponding conductive surface disposed on the return pad, the conductive surface of the connector including a conductive adhesive disposed thereon and a non-conductive adhesive disposed above the periphery of the conductive surface of the connector for engagement with a corresponding non-conductive adhesive disposed above the periphery of the conductive surface of the return pad. The connector can include a magnet for magnetically coupling the connector to the conductive surface disposed on the return pad.



WO 02/099442 A2

RETURN PAD CABLE CONNECTOR

5 BACKGROUND

1. Technical Field

The present disclosure relates to a return pad cable connector and, more particularly, to a return pad cable connector having a reusable cable configuration and adapted to removably receive a disposable single use patient return pad.

10

2. Background of Related Art

Flexible conductive members (i.e., return pads, return electrodes, etc.) are of particular importance in the medical community wherein patients often need to be connected to electrical monitoring or electrical generating equipment. In such applications, flexible conductive members such as return pads or electrodes need to adapt to the shape of the patient's body in order to provide sufficient electrical contact with the surface of the patient's body.

15

Electrosurgery requires that an electrosurgical generator be connected to at least two electrodes to produce and deliver an electrical potential to a patient's body. For example, in monopolar electrosurgery, the electrodes usually consist of an active electrode applied at the surgical site and a return electrode or pad applied to a non-surgical site on the patient.

20

Generally, return electrodes are pliable and thus can be flexed or shaped to meet particular application requirements. Return electrodes are usually manufactured to attach with a pressure sensitive adhesive directly to the surface of the patient's body. Return electrodes are therefore designed and manufactured to be form fitting or flexible so as to provide adequate conductive contact with the non-flat surfaces of a patient's body. Typically a conductive adhesive is applied to the surface of the return electrode to hold and secure the return electrode to the patient's body.

25

The return electrodes need to be electrically connected to the source electrosurgical generator. This connection is usually provided by way of one or more insulated conductive wires which are configured to interface with the electrosurgical generator to complete the

30

electrosurgical circuit. In the past, emphasis was placed on providing a tight physical connection between the conductive wire and the return electrode which could withstand potential disengagement of the conductive wire and return pad during a surgical procedure.

5 Contemporary wire termination and connection methods usually require that the ends of a wire be stripped of insulation, formed, and assembled to the flexible conductive member with a staple shaped attachment or some other attachable fastener such as a circular terminal and a rivet. The stripping process is highly dependent upon the nature of the insulation of the wire, the strip tooling design, and the tooling setup. Wire stripping problems can result in broken wire strands or wires that cannot be formed or terminated properly in subsequent
10 operations. As can be appreciated, existing terminating and connection manufacturing processes tend to be overly complex and typically require tedious manufacturing steps to assure adequate electrical and mechanical connections. Inadequate electrical connections can result in impedance changes across the tissue which may effect the performance of the overall electrosurgical system.

15 In addition, for sanitary and medical reasons, after a return electrode (i.e., return pad) has been used in a medical procedure for a particular patient, the return pad is discarded and a new return pad is used for a new medical procedure for either the same or a different patient. Since return pads of the prior art are usually physically coupled to the conductive wire (i.e., hard wired), the conductive portion and generation leads are discarded along with the return
20 pad. Typically, only the return pad needs to be discarded after each medical procedure for sanitary reasons. Disposal of both the return pad and the conductive portion simply increases the costs associated with the medical procedure.

25 Accordingly, the need exists for a return pad/electrode cable connector which incorporates a disposable return pad which is removably coupled to a reusable conductive portion/connector.

SUMMARY

30 A return pad cable connector, in accordance with the present disclosure, for use with a disposable return pad, includes a cord having a conductive wire disposed therethrough which conductive wire interconnects the return pad cable connector to an electrosurgical energy source. The return pad further includes operatively coupled to the cord, the

interface having an insulated backing and a conductive surface which is disposed on the insulated backing and has an area less than an area of the insulated backing and defines a border. The conductive surface is selectively engageable with a corresponding conductive surface of the return pad, the conductive surface of the interface being connected to the
5 conductive wire of the cord. A conductive adhesive is disposed on the conductive surface of the interface and a non-conductive adhesive is disposed on the border of the insulated backing, the border being engageable with a corresponding non-conductive adhesive disposed above the periphery of the conductive surface of the return pad.

In still yet another embodiment, according to the present disclosure the cord-to-pad
10 connector includes a base element having a handle and a fixed jaw having a conductive surface affixed to an inner surface thereof. A distal end of the conductive wire passes through the base element and operatively engages the conductive surface of the fixed jaw. The cord-to-pad connector further includes a return pad clamp pivotally mounted to the base element. The cord-to-pad connector is positionable between an open position wherein the
15 return pad clamp is spaced from the fixed jaw and a closed position wherein the return pad clamp is in contact with the fixed jaw. Preferably, the return pad clamp includes a moveable jaw and a clamping lever depending therefrom and extending along the handle which allows a user to selectively engage and disengage a return pad.

Preferably, the cord-to-pad connector further includes a locking mechanism
20 configured and adapted to selectively maintain the cord-to-pad connector in the closed position. The locking mechanism includes a latch projecting from the clamping lever of the return pad clamp and a locking rail projecting from a locking aperture formed in the handle. In use, the latch operatively engages the locking rail, thereby locking the cord-to-pad connector in the closed position.

Preferably, the return pad includes a pad-to-cord connector which has a conductive
25 pad surface disposed thereon which conductive pad surface is configured and adapted to operatively engage the conductive surface of the base element. In this manner, an electrical connection between the return pad and the cord-to-pad connector is established. A conductive adhesive may be disposed between the conductive pad surface and the conductive
30 surface of the base element to facilitate the electrical connection and to maintain electrical continuity between elements.

In an alternative embodiment, the return pad cable connector of the present disclosure includes a cord having a conductive wire disposed therethrough which connects to an

electrosurgical energy source and a connector which operatively couples to the cord wherein the connector has at least one magnet disposed thereon for magnetically coupling the connector to a conductive surface disposed on the return pad. In accordance with the present disclosure, when the connector is magnetically coupled to the conductive surface disposed on the return pad energy is permitted to pass from the return pad to the electrosurgical energy source via the conductive wire.

Preferably, the at least one magnet is made from an electrically conductive material. More preferably, the conductive wire of the cord is electrically coupled to the at least one electrically conductive magnet.

10 In an alternative embodiment, the connector further includes at least one electrical contact disposed on the surface of at least one of the magnets. Preferably, the conductive wire of the cord is electrically coupled to each of the at least one electrical contacts.

In still an alternative embodiment, the connector includes a flexible substrate having a first portion and a second portion integrally connected to the first portion, the first and second portion defining a fold line therebetween and a magnet disposed on each of the first and second portions of the flexible substrate in order to sandwich the conductive surface of the return pad therebetween. Preferably, the conductive wire of the cord is electrically coupled to the magnet, such that when the connector is magnetically coupled to the conductive surface disposed on the return pad, energy is permitted to pass from the return pad to the electrosurgical energy source via the conductive wire.

20 It is envisioned that at least the magnet which is electrically coupled to the conductive wire is made from an electrically conductive material. Preferably, the connector further includes at least one electrical contact disposed on the surface of the magnet which is electrically coupled to the conductive wire. The conductive wire of the cord is preferably electrically coupled to each of the at least one electrical contacts.

It is envisioned that the conductive wire of the cord can extend from a side of the substrate which is either parallel to the fold line or transverse to the fold line. It is further envisioned that each magnet is coupled to the substrate via a pin passing through the magnet and into the substrate.

30 These and other advantages and features of the apparatus disclosed herein, will become apparent through reference to the following description of embodiments, the

accompanying drawings and the claims.

BRIEF DESCRIPTION OF THE DRAWINGS

5 The accompanying drawings, which are incorporated in and constitute a part of this specification, illustrate embodiments of the invention and, together with a general description of the invention given above, and the description of the embodiments given below, serve to explain the principles of the invention.

FIG. 1 is a bottom plan view of a return pad and an electrode cable connector in accordance with the present disclosure;

10 FIG. 2 is a perspective view of a return pad and an electrode cable connector in accordance with an alternative embodiment of the present disclosure;

FIG. 3 is a perspective view of a return pad and an electrode cable connector in accordance with yet another embodiment of the present disclosure;

15 FIG. 4 is an exploded, perspective view of a return pad and an electrode cable connector similar to the embodiments shown in FIG. 3;

FIG. 5 is a cross-sectional side elevational view of the electrode connector of FIG. 4 shown in the closed position;

FIG. 6 is a cross-sectional side elevational view of the electrode connector of FIG. 4 shown in the open position;

20 FIG. 7 is a top plan view of an electrode cable connector in accordance with an alternative embodiment of the present disclosure;

FIG. 8 is a top plan view of an electrode cable connector in accordance with yet another embodiment of the present disclosure;

25 FIG. 9 is a perspective view of an electrode cable connector in accordance with still another embodiment of the present disclosure; and

FIG. 10 is a side elevational view of an electrode cable connector of FIG. 9 illustrating a preferred method of coupling of a magnet to a substrate thereof.

DETAILED DESCRIPTION

30 Preferred embodiments of the presently disclosed return pad cable connector will now be described in detail with reference to the drawing figures wherein like reference numerals

identify similar or identical elements.

Referring now in detail to FIG. 1, a return pad cable connector is shown in accordance with the present disclosure and is generally identified as 100. Cable connector 100 includes a reusable conductive wire cable 102 which operatively couples at a proximal end thereof to an electro-surgical generator "E/S" and a reusable cord-to-pad interface 104 which is disposed at a distal end thereof. Cord-to-pad interface 104 includes an insulated backing 106 having a conductive cord surface 108 disposed thereon which electrically couples to a wire 107 passing through cable 102.

An adhesive border 110 is defined about the outer periphery of the conductive cord surface 108. It is contemplated that conductive cord surface 108 may be positioned along one edge of cord-to-pad interface 104 to facilitate connection with the return pad 120. However, it is also envisioned that the conductive cord surface 108 or multiple conductive cord surfaces 108 may be arranged anywhere on the surface of the cord-to-pad interface 104 depending upon a particular purpose or to facilitate electrical engagement. Preferably, the adhesive border 110 includes a non-conductive adhesive 112 applied thereto which reduces stray electrical current from emanating from the conductive cord surface 108.

As seen in FIG. 1, cable connector 100 is configured and adapted to be removably adhered to a return pad or return electrode 120. Return pad 120 includes an insulated backing 122, an insulated cover 124 and a conventional electrically conductive member 126 retained between insulated backing 122 and insulated cover 124.

Insulated backing 122 includes a pad-to-cord interface 128 which extends from a side surface thereof. Pad-to-cord interface 128 includes a conductive pad surface 130, preferably made from an electrically conductive material, disposed thereon which electrically couples return pad 120 to the conductive cord surface 108. Conductive pad surface 130 is electrically connected to conductive member 126 (via at least one conductive wire 132 which is disposed between backing 122 and cover 124). An adhesive border 134 is defined about the outer periphery of the conductive cord surface 108. It is contemplated that conductive pad surface 130 is positioned to compliment the particular arrangements of conductive surface(s) 108 on the cord-to-pad interfaces. Much like adhesive border 110, adhesive border 134 may also include a non-conductive adhesive 112 applied thereto to facilitate engagement and reduce stray electrical currents.

A non-conductive adhesive for adhering adhesive border 110 of cord-to-pad interface 104 to adhesive border 134 of pad-to-cord interface 128 is disclosed in commonly owned U.S. Patent No. 4,699,146 to Sieverding.

By providing cord-to-pad interface 104 with an adhesive border 110 and
5 providing pad-to-cord interface 128 with an adhesive border 134, sufficient electrical connection is established between conductive cord surface 108 and conductive pad surface 130. More particularly, cord-to-pad interface 104 is adhered to pad-to-cord interface 128 by applying the non-conductive adhesive 112 to their respective adhesive borders 110 and 134 and pressing the two interfaces together. In this manner, conductive cord surface 108 directly
10 contacts conductive pad surface 130 thereby establishing an electrical connection therebetween.

Turning now to FIG. 2, a return pad cable connector is shown in accordance with another embodiment of the present disclosure and is generally identified as cable connector 200. Cable connector 200 includes a reusable conductive wire cable 202 having a typical
15 connector 204 attached to a proximal end thereof for interfacing cable 202 with an electrosurgical generator (not shown) and a reusable cord-to-pad interface 206 operatively coupled to a distal end thereof. Cord-to-pad interface 206 includes an insulated backing 208 having a pair of conductive cord surfaces 210a, 210b disposed thereon which electrically couple to a wire 212 passing through cable 202.

20 Conductive cord surfaces 210a, 210b are preferably spaced from one another and extend distally along a top surface 211 of cord-to-pad interface 206. An adhesive border 214 is defined about the periphery of each conductive cord surface 210a, 210b. Adhesive border 214 may include a non-conductive adhesive 216 applied thereto in order to facilitate mechanical connection with return pad 220. A conductive adhesive 218a, 218b is applied to
25 each conductive cord surface 210a, 210b, respectively.

As seen in FIG. 2, cable connector 200 is configured and adapted to be removably adhered to return pad 220. Return pad 220 is similar to return pad 120 of FIG. 1 but includes a pair of complimentary conductive surfaces 230a, 230b which electrically couple with conductive pad surfaces 210a, 210b, respectively. Each conductive surface 230a, 230b, in
30 turn, is coupled to a conductive member 236a, 236b disposed within the return pad 220.

More particularly, return pad 220 includes an insulated backing 222 having a pad-to-

cord interface 228 which extends from a side surface thereof. Pad-to-cord interface 228 includes the pad conductive surfaces 230a, 230b disposed thereon which couple with conductive cord surfaces 210a, 210b. An adhesive border 234 surrounds the periphery of each conductive pad surface 230. Adhesive border 234 is configured to include a non-
5 conductive adhesive 216 applied thereto which reduces stray current which may emanate from the conductive surfaces. A conductive adhesive 218 and covers each conductive pad surface 230a, 230b to facilitate and maintain electrical connection with conductive cord surfaces 210a, 210b.

Preferably, a conductive adhesive 218 is selected such that the conductivity of the
10 adhesive will be sufficient for the electrosurgical power to be conducted through the small area of the attachment as well as provide impedance low enough for contact quality monitoring in the generator. While a non-conductive and a conductive adhesive have been contemplated for use in the present embodiment, it is envisioned that a single conductive adhesive can be applied to both adhesive borders 214 and 234 as well as to both conductive
15 surfaces 210a, 210b and 230a, 230b. Adhesive 218a, 218b is selected such that the electro-conductivity of the adhesive promotes the transfer of electric signals between conductive surfaces 210a, 210b and 230a, 230b.

Turning now to FIGS. 3-6, a return pad cable connector is shown in accordance with another embodiment of the present disclosure and is generally identified as 300. Cable
20 connector 300 includes two major subunits; a base element 302 and a return pad clamp 304 (see FIG. 4). As explained in greater detail below, base element 302 and return pad clamp 304 cooperate to grip the return pad 400. It is contemplated that both base element 302 and return pad clamp 304 are preferably molded from a strong, resilient plastic material, such as acetal resin.

25 Base element 302 includes a return pad interface 306 and a handle 308. Preferably, handle 308 is dimensioned to facilitate gripping and may be ergonomically shaped to enhance "feel".

Return pad interface 306 preferably includes a fixed jaw 312 having an L-shaped cross-section defined by a first leg 310 for housing a series of pivot mounts 336 disposed
30 therein and a second leg 311 which vertically extends therefrom which cooperates with the pad clamp 304 to secure the return pad 400 as explained in more detail below. A lever

housing 314 is formed in the pad interface 306 and operates to mechanically align and secure the pad clamp 304 with handle 308. More particularly, a locking aperture 316 extends through handle 308 and is located toward the distal end of the same (308). As explained in more detail below, locking aperture 316 and lever housing 314 cooperate to align and secure
5 the pad clamp 304 within handle 308.

Return pad clamp 304 includes a movable jaw 318 and a clamping lever 320 which depends from movable jaw 318 and which is designed to mechanically engage handle 308. Clamping lever 320 includes a proximal half 322 having an offset 324 which extends at an angle relative to proximal half 322. A distal half 326 depends from offset 324 such that
10 proximal half 322, offset 324 and distal half 326 form a generally reverse "S" configuration which facilitates assembly of the cable connector 300. In other words, the proximal and distal halves 322 and 326 are generally parallel to one another and offset 324 is disposed perpendicular thereto. Movable jaw 318 also includes a series of pivot projections 334 which are designed for mechanical engagement with pivot mounts 336 as discussed below.

15 A locking pivot grip 328 is disposed on the proximal half 322 of the return pad clamp 304 and a corresponding unlocking pivot grip 330 is formed on the distal half 326. The locking and unlocking pivot grips 328 and 330 are designed to facilitate movement of clamping lever 320 by an operator's finger to mechanically move/pivot jaw member 318 from a first open position for reception of the return pad 400 to the second locking position
20 which secures the return pad 400 in electromechanical engagement with the cable connector 300.

Return pad clamp 304 is pivotally mounted to base element 302 so that movable jaw 318 lies in registration with fixed jaw 312 and pivots about an axis "A" (see FIGS. 5 and 6) defined through first leg 310 of the return pad interface 306. More particularly, the return pad
25 clamp 304 is mounted by passing clamping lever 320 through lever housing 314 and engaging the pivot projections 334 within the corresponding pivot mounts 336 disposed in first leg 310.

Clamping lever 320 when mounted extends along handle 308, preferably lying in a channel 338 defined therein. More particularly, clamping lever 320, when mounted, extends
30 through lever housing 314 and to locking aperture 316 such that the distal half 326 is movable within locking aperture 316 from a first locking position wherein movable jaw is

secured to the return pad 400 (see FIG. 5) to a second open position for disengaging the return pad 400 (see FIG. 6). Preferably, locking aperture 316 is designed to accept and cooperate with clamping lever 320 in the manner described above. For example, in one embodiment, locking aperture 316 is generally keyhole shaped, with a rectangular portion
5 designed to accommodate distal half 326 of clamping lever 320, and a circular, chamfered thumb well 340 which surrounds un-locking grip 330. The length of offset 324 is preferably dimensioned to allow proximal half 322 to lie generally flush with the outer surface of handle 308 when clamping lever 320 is disposed in the "locked" position. Also, when locked, distal half 326 is generally flush with the opposite surface of handle 308.

10 A locking rail 342 is disposed within locking aperture 316 and is designed to mechanically engage a corresponding latch 332 disposed on offset 324 to secure clamping lever 320 in a "locked" position which, in turn, locks the cable connector 300 to the return pad 400. As can be appreciated, cooperation between locking rail 342 and latch 332 is made possible by dimensioning clamping lever 320 such that the distance from axis A to the tip of
15 latch 332 is slightly less than the distance from that point to the tip of locking rail 342. Thus, when the unit is in a locked position, as shown in FIG. 5, latch 332 is securely retained by locking rail 342. As described in more detail below, movement of distal half 326 via un-locking grip 330 in direction "D" disengages latch 332 from locking rail 342 which, in turn, disengages/unlocks the clamping lever 320 and releases the return pad 400.

20 As best shown in FIG. 4, base element 302 also includes a conductive surface 344 affixed to an inner facing surface of fixed jaw 312 which couples with a conductive wire 346 extending from handle 308 to the electrosurgical generator (not shown).

Returning to FIG. 3, cable connector 300 is configured and adapted to be removably coupled to return pad 400. Return pad 400 includes an insulated backing 402, an insulated
25 cover 404 and a conventional electrically conductive member 406 retained between insulated backing 402 and insulated cover 404.

Insulated backing 402 includes a pad-to-cord connector 408 extending from a side surface thereof. Pad-to-cord connector 408 includes a conductive pad surface 410 disposed thereon for electrically connecting return pad 400 to conductive surface 344 of connector 300.

30 Conductive pad surface 410 is electrically connected to conductive member 406 via a conductive path 412. An adhesive border 414 surrounds conductive pad surface 410 and is

configured such that a non-conductive adhesive 416 can be applied thereto. It is contemplated that a conductive adhesive can be applied between conductive surface 344 of connector 300 and pad conductive surface 410 to assure electrical continuity between the same.

5 As seen in FIG. 5, while in a locked position connector 300 firmly holds return pad 400 between fixed and movable jaws 312 and 318, respectively, via the mechanically cooperative action of latch 332 and locking rail 342. In this manner, conductive surface 344 of connector 300 and conductive pad surface 410 of return pad 400 are held in electrical contact with one another. In the open position, as shown in FIG. 6, movable jaw 318 is
10 rotated away from fixed jaw 312, permitting insertion and removal of return pad 400 therefrom.

Movement between the open and the closed/locked positions is shown in FIGS. 5 and 6. To move from the closed/locked position (as seen in FIG. 5), the operator applies a force in the direction "D" to unlocking grip 330, preferably by pressing with a thumb or finger. By
15 applying a force in the direction "D" the distal half 326 and latch 332 unlocks causing the movable jaw 318 of clamping member 320 to pivot away from fixed jaw 312 and release pad 400. In turn, offset 324 rotates upward, forcing the proximal half 322 out of channel 338. More particularly, applying a force in the direction "D" rotates the pivot projections 334 within pivot mounts 336 to cause movable jaw 318 to open. Once rotated to the "open"
20 position, the return pad 400 is either released or a new return pad may be positioned therein.

Once the return pad 400 is in place between the movable jaw 318 and the fixed jaw 312, the connector 300 can be locked. Locking of connector 300 involves applying a force in a direction "C" to locking grip 328. This forces latch 332 against locking rail 342, causing proximate leg 322 to flex and rotate latch 332 beyond locking rail 342 thus moving clamp
25 lever 320 to a "locked" position (see FIG. 5). In turn, the pivot projections of moveable jaw 318 are rotated within pivot mounts 336 of fixed jaw 316 thereby securing return pad 400 between the jaw members 312, 318.

In accordance with the present disclosure, it is envisioned that each jaw member 312, 318 may be provided with a plurality of teeth 317 formed on either conductive surface 344 of
30 connector 300, the non-conductive surface of second leg 311 of fixed jaw 312 or both. Accordingly, the plurality of teeth 317 increases the retention of pad-to-chord connector 408

of return pad 400 therebetween.

Turning now to FIGS. 7-10 a return pad cable connector is shown in accordance with the principles of the present disclosure and is generally identified as 500. In accordance with the present disclosure it is envisioned that return pad cable connector 500 is configured and adapted to cooperate with a return electrode 120 as generally described above.

With particular reference to FIG. 7, return pad cable connector 500 includes a conductive return wire cable 502, operatively coupled at a proximal end thereof to an electrosurgical generator (not shown), and a cord-to-pad interface 504 operatively coupled to a distal end thereof. In accordance with the present disclosure, it is envisioned that cord-to-pad interface 504 is made of an electrically conductive magnetic material. Accordingly, when cord-to-pad interface 504 is approximated toward or brought into contact with conductive pad surface 130 of return pad 120, interface 504 will magnetically couple with conductive pad surface 130. As such, the contact between cord-to-pad interface 504 and conductive pad surface 130 will return energy during electrosurgical procedures, from return pad 120 to the electrosurgical generator (not shown).

Turning now to FIG. 8, return pad cable connector 500 includes a conductive return wire cable 502, operatively coupled at a proximal end thereof to an electrosurgical generator (not shown), and a cord-to-pad interface 510 operatively coupled to a distal end thereof. In accordance with the present embodiment, cord-to-pad interface 510 includes a magnetic substrate 512 having at least one electrical contact 514 disposed thereon, wherein wire cable 502 is electrically coupled to electrical contact(s) 514. It is envisioned that magnetic substrate 512 can be made from either conductive or non-conductive materials. Accordingly, when cord-to-pad interface 510 is approximated toward or brought into contact with conductive pad surface 130 of return pad 120, such that the at least one electrical contact 514 will be brought into contact with conductive pad surface 130, interface 510 will magnetically couple with conductive pad surface 130. As such, the contact between cord-to-pad interface 510 and conductive pad surface 130 will return energy during electrosurgical procedures, from return pad 120 to the electrosurgical generator (not shown).

Turning now to FIG. 9, return pad cable connector 500 includes a conductive return wire cable 502, operatively coupled at a proximal end thereof to an electrosurgical generator (not shown), and a cord-to-pad interface 520 operatively coupled to a distal end thereof.

Cord-to-pad interface 520 includes a flexible substrate 522 having a first portion 524 and a second portion 526 integrally connected to first portion 524 to thereby define a fold line 528. Cord-to-pad interface 520 further includes an electrically conductive magnet 530 provided on each of first and second portions 524, 526 of substrate 522, wherein wire cable 502 is
5 electrically coupled to one of the pair of magnets 530. While a pair of electrically conductive magnets 530 is disclosed, it is contemplated that only magnet 530, which is electrically coupled to wire cable 502, needs to be made from an electrically conductive material while the other magnet can be made from non-conductive materials. It is further envisioned that, if
10 both magnets 530 are non-conductive, an electrical contact (not shown) can be disposed on magnet 530 which is electrical contact is electrically coupled to wire cable 502.

As seen in FIG. 9, wire cable 502 can extend from return pad cable connector 500 from a side of substrate 522 which is parallel to fold line 528, or in the alternative, as shown in phantom, wire cable 502 can extend from return pad cable connector 500 from a side of substrate 522 which is transverse to fold line 528.

15 Use of return pad cable connector 500, shown in FIG. 9, requires that after conductive pad surface 130 of return pad 120 is brought into contact with magnet 530 with is electrically coupled to wire cable 502, flexible substrate 522 is folded along fold line 528 in order to approximate magnets 530 of first and second portions 524, 526 toward one another thereby sandwiching conductive pad surface 130 therebetween. As such, the contact between magnet
20 530, coupled to wire cable 502, and conductive pad surface 130 will return energy during electrosurgical procedures, from return pad 120 to the electrosurgical generator (not shown).

As seen in FIG. 10, a preferred method of coupling a magnet to a substrate for a return pad cable connector 500 is illustrated. In particular, a magnet 540 overlies a substrate 542 and at least one retaining device 544 (i.e., a pin) is used to pass through magnet 540 and
25 imbedded in substrate 542 to secure magnet 540 to substrate 542. Further, as seen in FIG. 10, wire cable 502 can be disposed between magnet 540 and substrate 542. While a pin has been disclosed it is envisioned that other methods of coupling the magnet to a substrate can be used, such as, for example, an adhesive, screws, clips, clamps and the like.

The use of magnets in return pad cable connector 500 results in easier attachment and
30 removal of return pad cable connector 500 from conductive pad surface 130 of return pad 120 as well as easier cleaning of the contact surfaces and a lower profile.

In accordance with the present disclosure, it is envisioned that return pad cable connector 500 can be used in combination with a conductive adhesive disposed between return pad cable connector 500 and conductive pad surface 130.

The above description should not be construed as limiting, but merely as
5 exemplifications of preferred embodiments. Those skilled in the art will envision other modifications within the scope and spirit of the present disclosure.

CLAIMS:

1. A return pad cable connector for selective connection to a disposable return pad, comprising:

a cord having a conductive wire disposed therethrough which connects to an electrosurgical energy source;

an interface operatively coupled to the cord and having:

an insulated backing;

a conductive surface disposed on the insulated backing and having an area less than an area of the insulated backing and defining a border, the conductive surface being selectively engageable with a corresponding conductive surface of the return pad, the conductive surface of the interface being connected to the conductive wire of the cord

a conductive adhesive disposed on the conductive surface of the interface; and

a non-conductive adhesive disposed on the border of the insulated backing, the border being engageable with a corresponding non-conductive adhesive disposed about the periphery of the conductive surface of the return pad.

2. The return pad cable connector according to claim 1, wherein the conductive surface of the interface includes at least two conductive surfaces which correspondingly mate with at least two conductive surfaces on the return pad.

3. The return pad cable connector according to claim 1, wherein the interface comprises:

a base element including a handle and a fixed jaw having a conductive surface affixed to an inner surface thereof, and wherein the distal end of said conductive wire passes through the base element and operatively engages the conductive surface; and

a return pad clamp pivotally mounted to the base element, the interface being positionable between an open position wherein the return pad clamp is spaced from the fixed jaw and a closed position wherein the return pad clamp is in contact with the fixed jaw.

4. The return pad cable connector according to claim 3, wherein the return pad clamp includes a moveable jaw and a clamping lever depending therefrom and extending along the handle.

5. The return pad cable connector according to claim 4, wherein the interface further includes a locking mechanism configured and adapted to selectively maintain the interface in the closed position.

6. The return pad cable connector according to claim 5, wherein the locking mechanism includes a latch projecting from the clamping lever of the return pad clamp; and

a locking rail projecting from a locking aperture formed in the handle, wherein the latch operatively engages the locking rail.

7. The return pad cable connector according to claim 1, wherein the conductive surface of the return pad interface is configured and adapted to operatively engage the conductive surface of the base element of the interface thereby establishing an electrical connection between the return pad and the interface.

8. The return pad cable connector according to claim 7, wherein an adhesive is disposed between the conductive surface of the return pad interface and the conductive surface of the base element.

9. The return pad cable connector according to claim 1, wherein the return pad connector selectably electrically couples the removable return pad to an electrosurgical generator.

10. A return pad cable connector for use with a disposable return pad, comprising:

a cord having a conductive wire disposed therethrough which connects to an electrosurgical energy source;

an insulated backing;

a connector which operatively couples to the cord, the connector having a

conductive surface and at least one magnet disposed on the insulated backing for magnetically coupling the connector to a conductive surface disposed on the return pad, wherein when the connector is magnetically coupled to the conductive surface disposed on the return pad electrosurgical energy is permitted to pass from the return pad to the electrosurgical energy source via the conductive wire, wherein the conductive surface of the connector is disposed on the magnet.

11. The return pad cable connector according to claim 10, wherein the at least one electrically conductive magnet is made from an electrically conductive material and wherein the conductive wire of the cord is electrically coupled to the at least one magnet.

12. The return pad cable connector according to claim 10, the connector further includes at least one electrical contact disposed on the surface of at least one of the magnets and wherein the conductive wire of the cord is electrically coupled to each of the at least one electrical contacts.

13. The return pad cable connector according to claim 10, wherein the connector comprises:

a flexible substrate having a first portion and a second portion integrally connected to the first portion, the first and second portion defining a fold line therebetween; and

a magnet disposed on each of the first and second portions of the flexible substrate in order to sandwich the conductive surface of the return pad therebetween, wherein the conductive wire of the cord is electrically coupled to the magnet, such that when the connector is magnetically coupled to the conductive surface disposed on the return pad, energy is permitted to pass from the return pad to the electrosurgical energy source via the conductive wire.

14. The return pad cable connector according to claim 13, wherein at least the magnet electrically coupled to the conductive wire is made from an electrically conductive material.

15. The return pad cable connector according to claim 13, wherein the connector further includes at least one electrical contact disposed on the surface of the magnet which is electrically coupled to the conductive wire and wherein the conductive wire of the cord is electrically coupled to each of the at least one electrical contacts.

16. The return pad cable connector according to claim 13, wherein the conductive wire of the cord extends from a side of the substrate which is parallel to the fold line or transverse to the fold line.

17. The return pad cable connector according to claim 13, wherein each magnet is coupled to the substrate via a pin passing through the magnet and into the substrate.

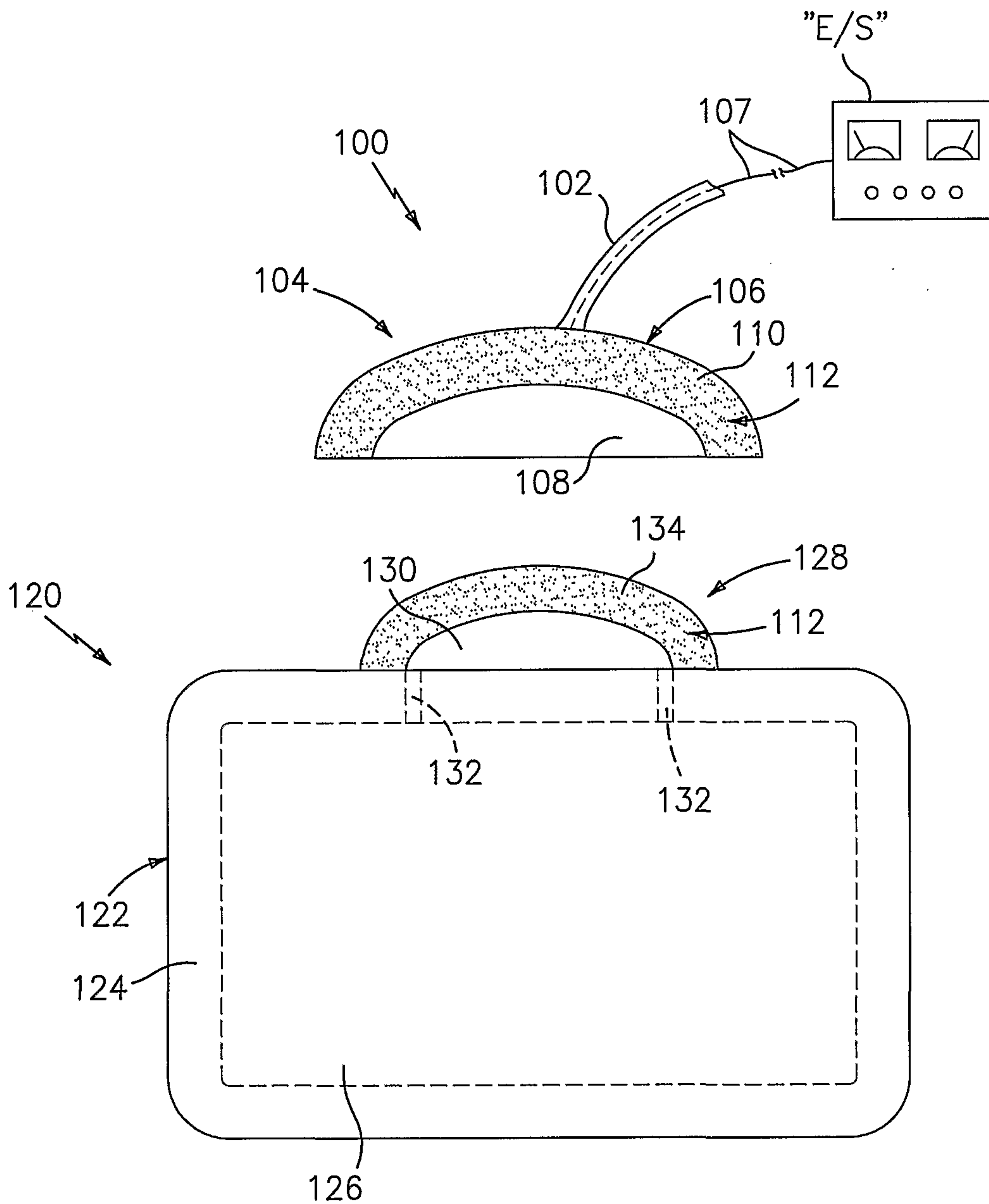

FIG. 1

2/6

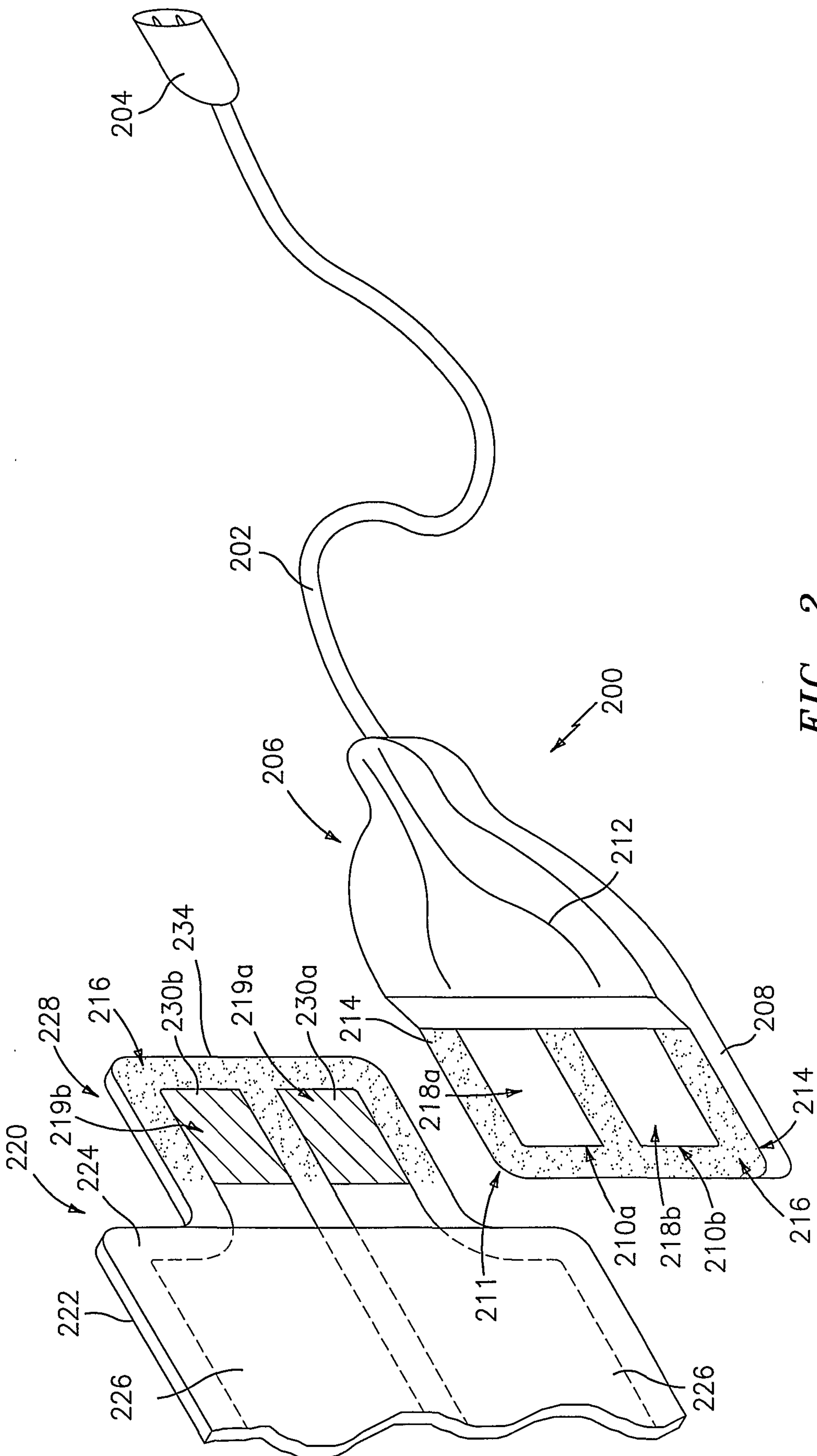
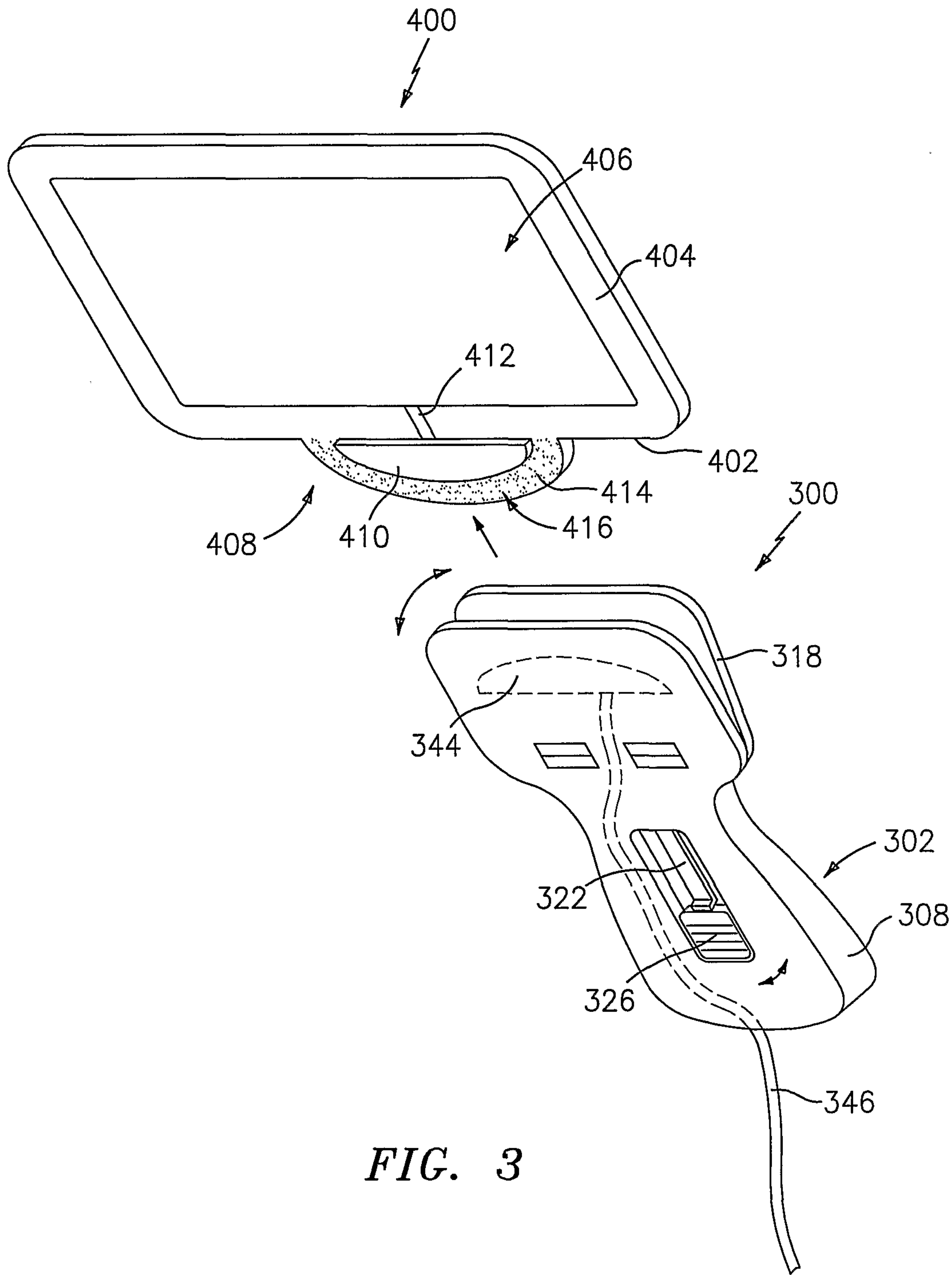

FIG. 2



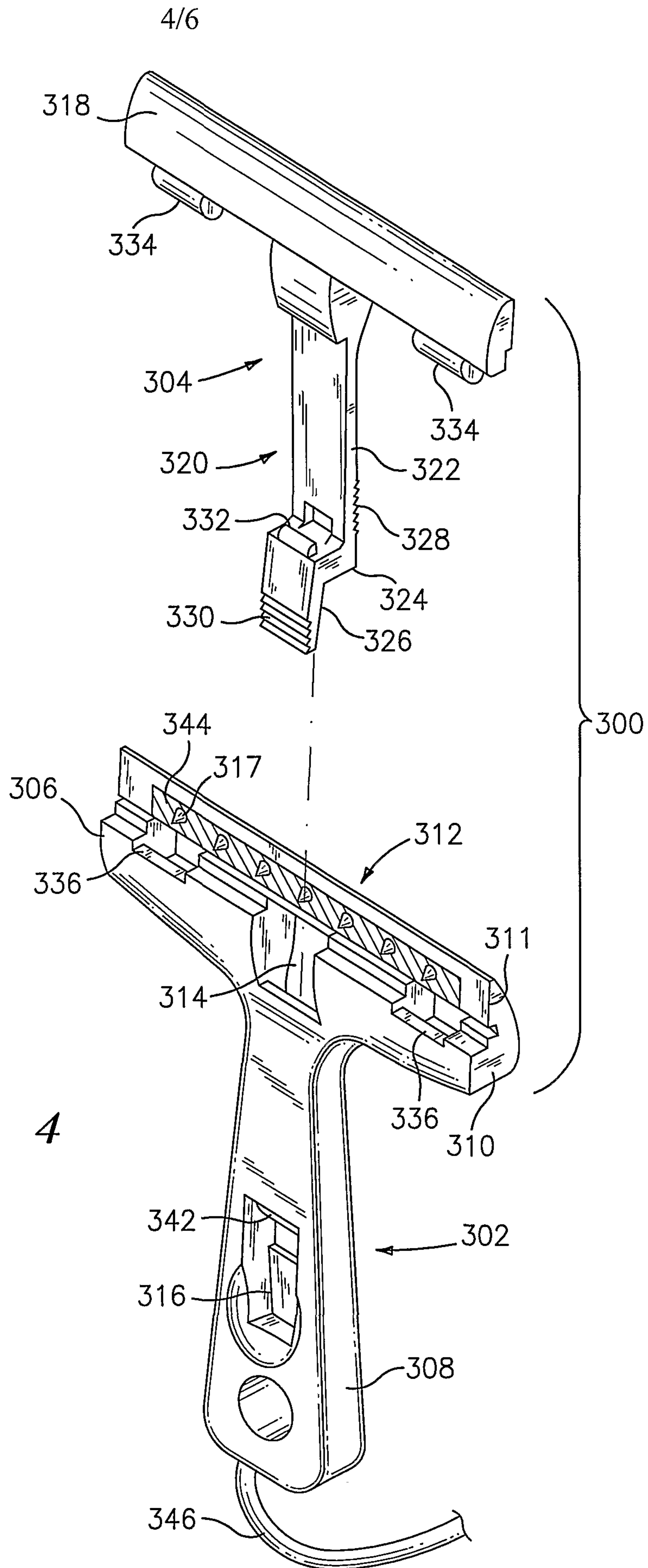

FIG. 4

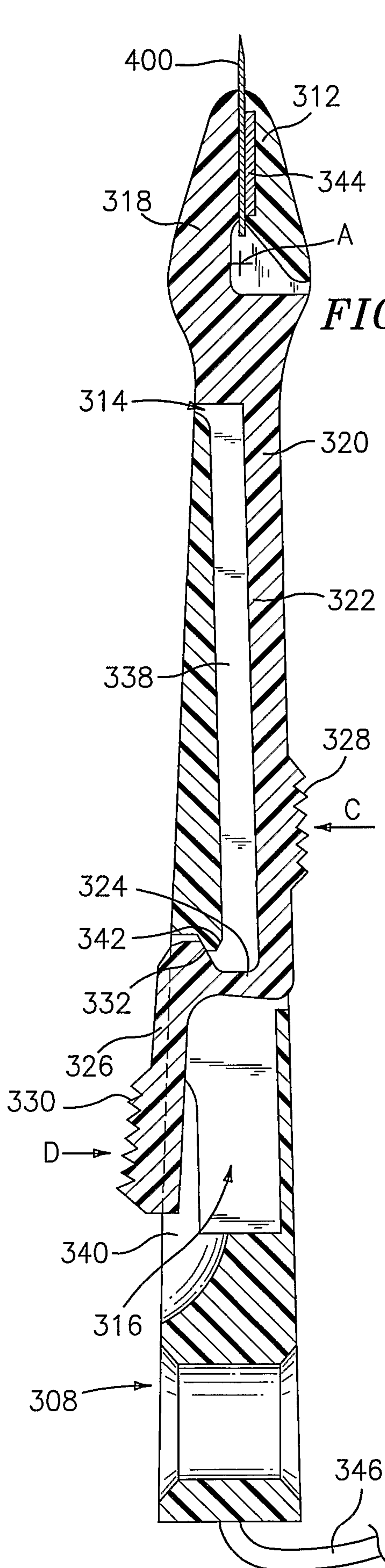

FIG. 5

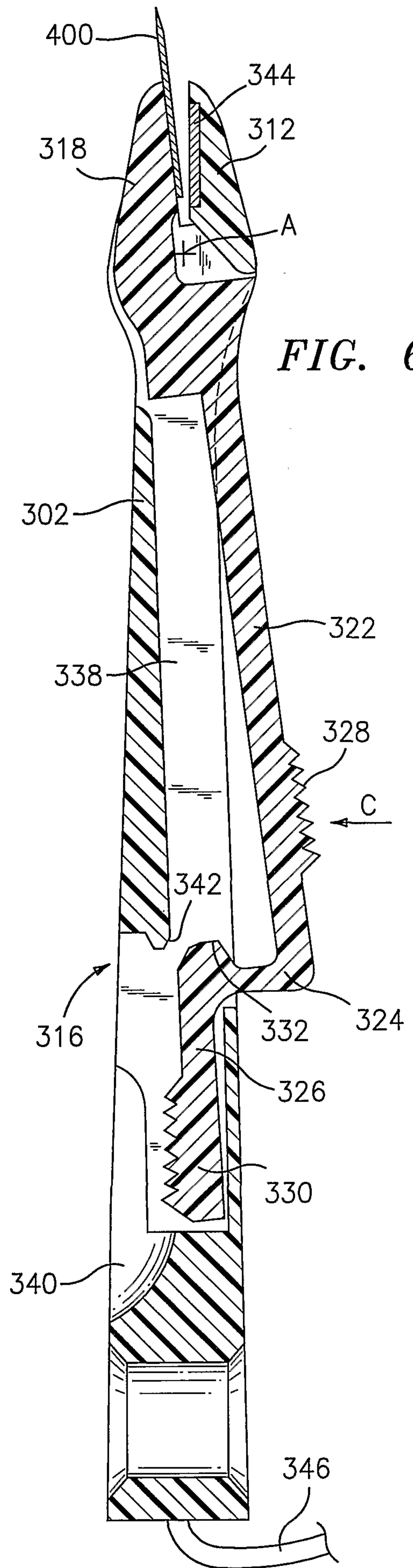

FIG. 6

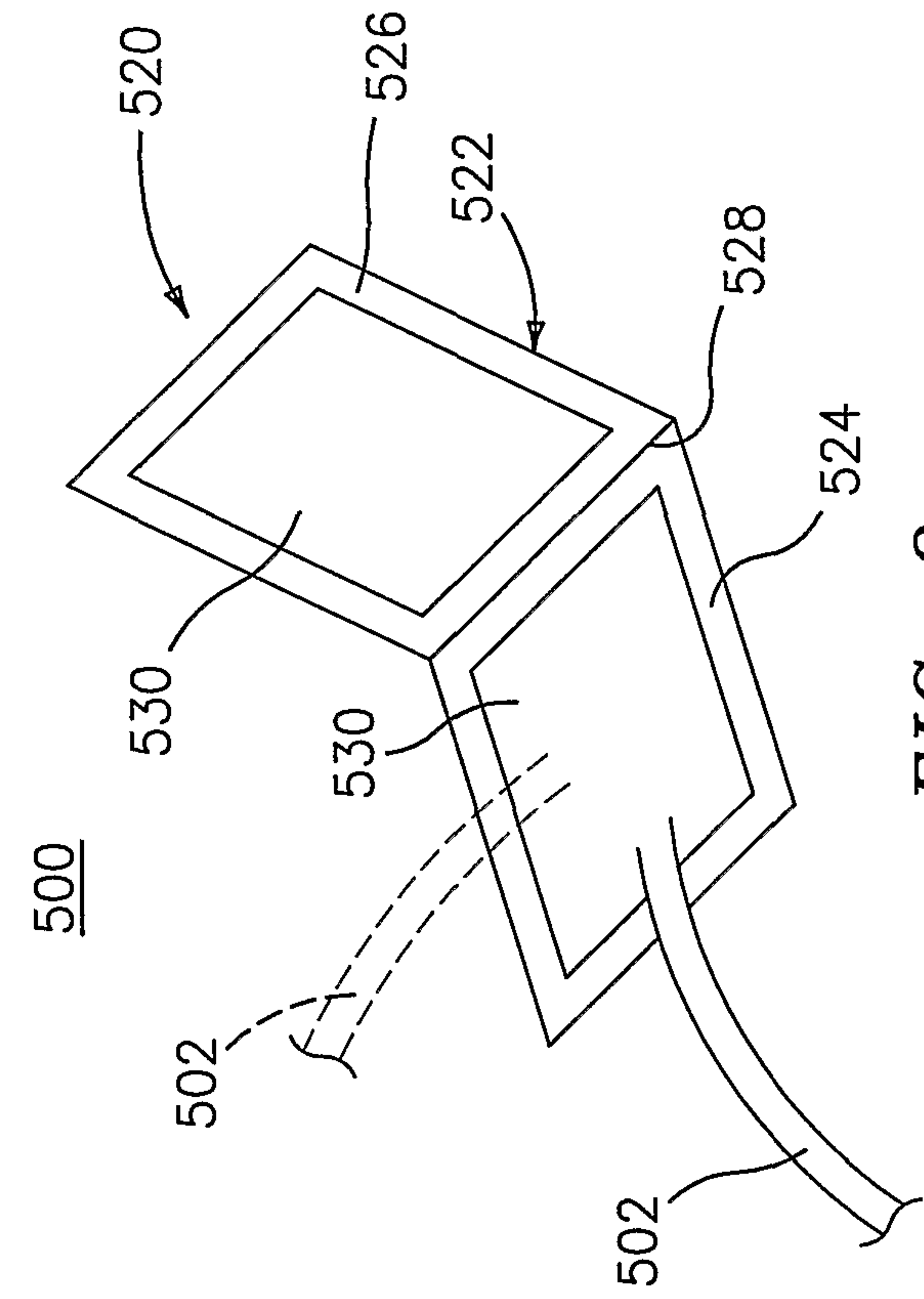

FIG. 9

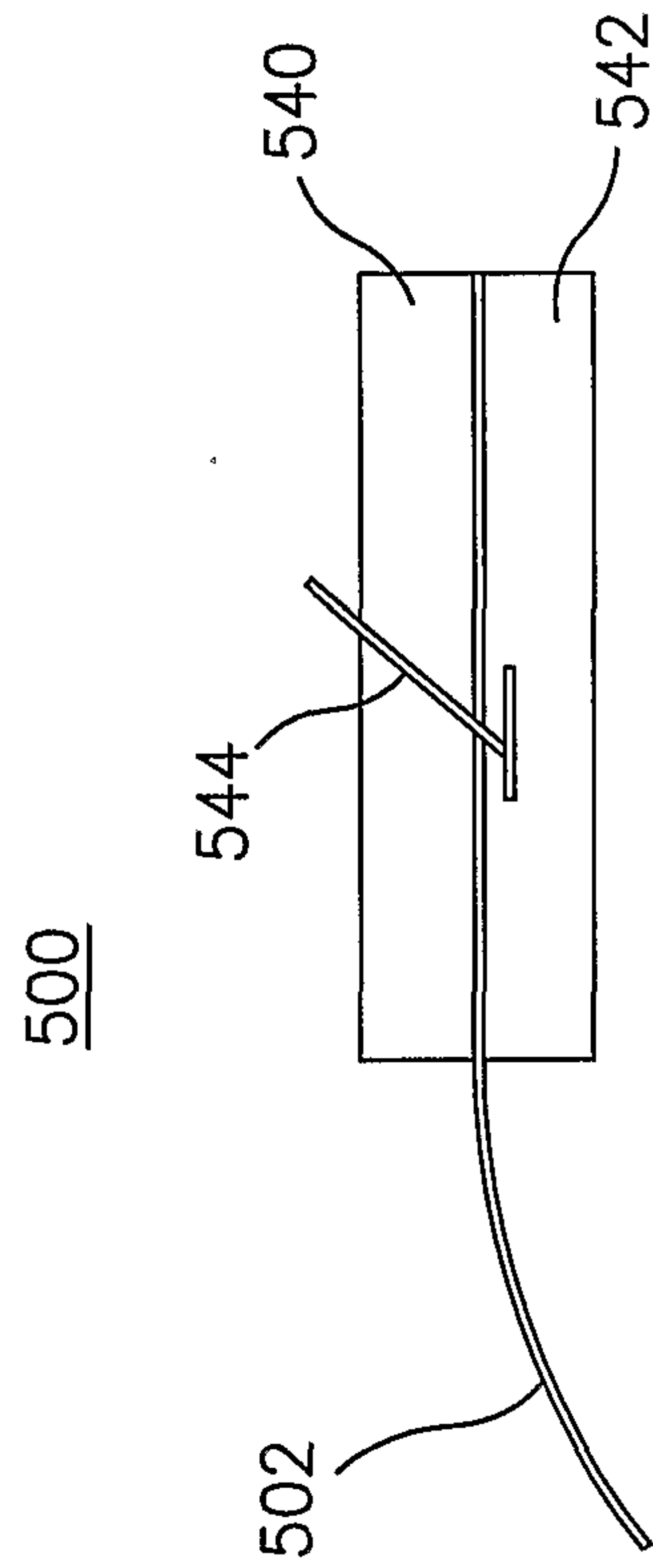

FIG. 10

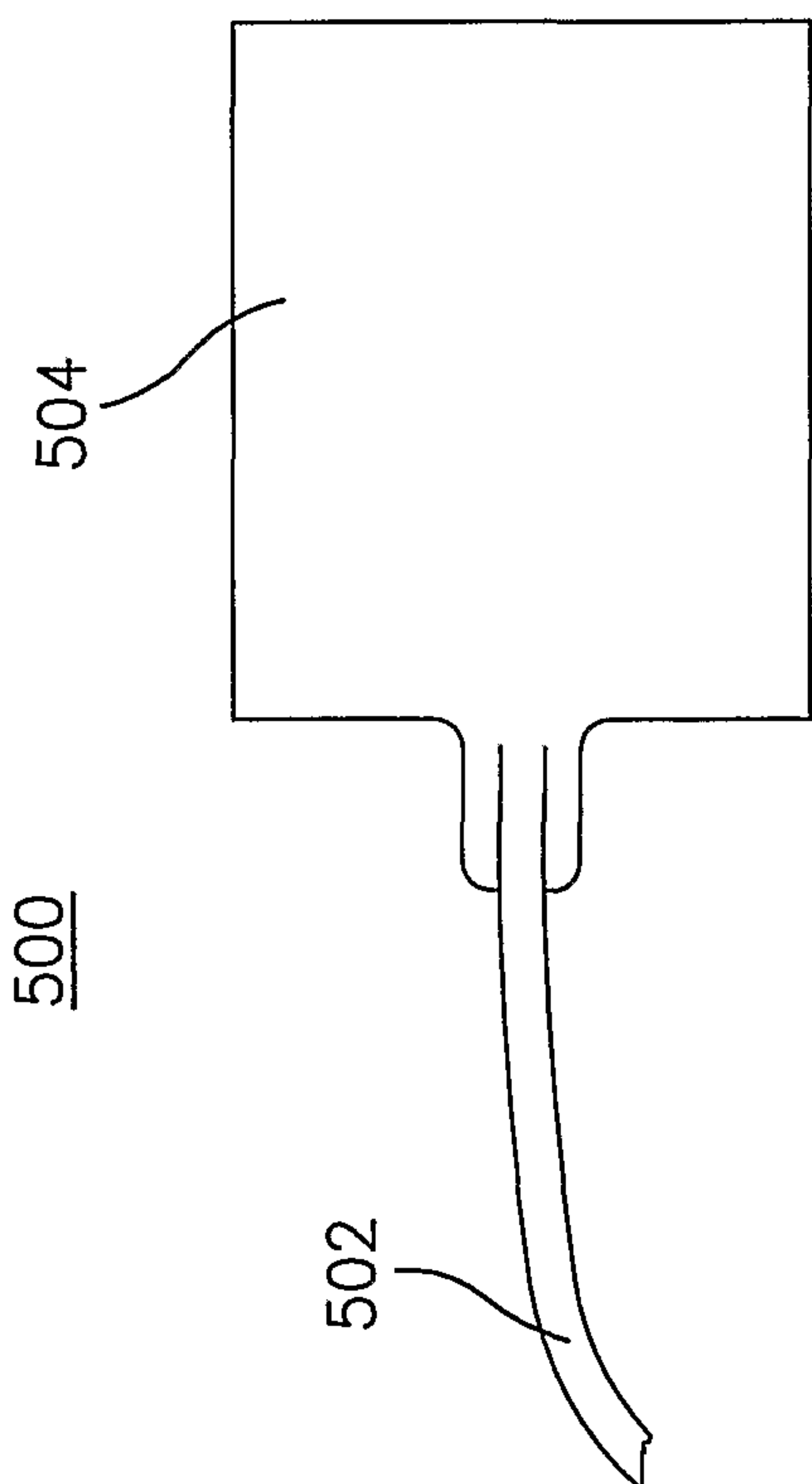

FIG. 7

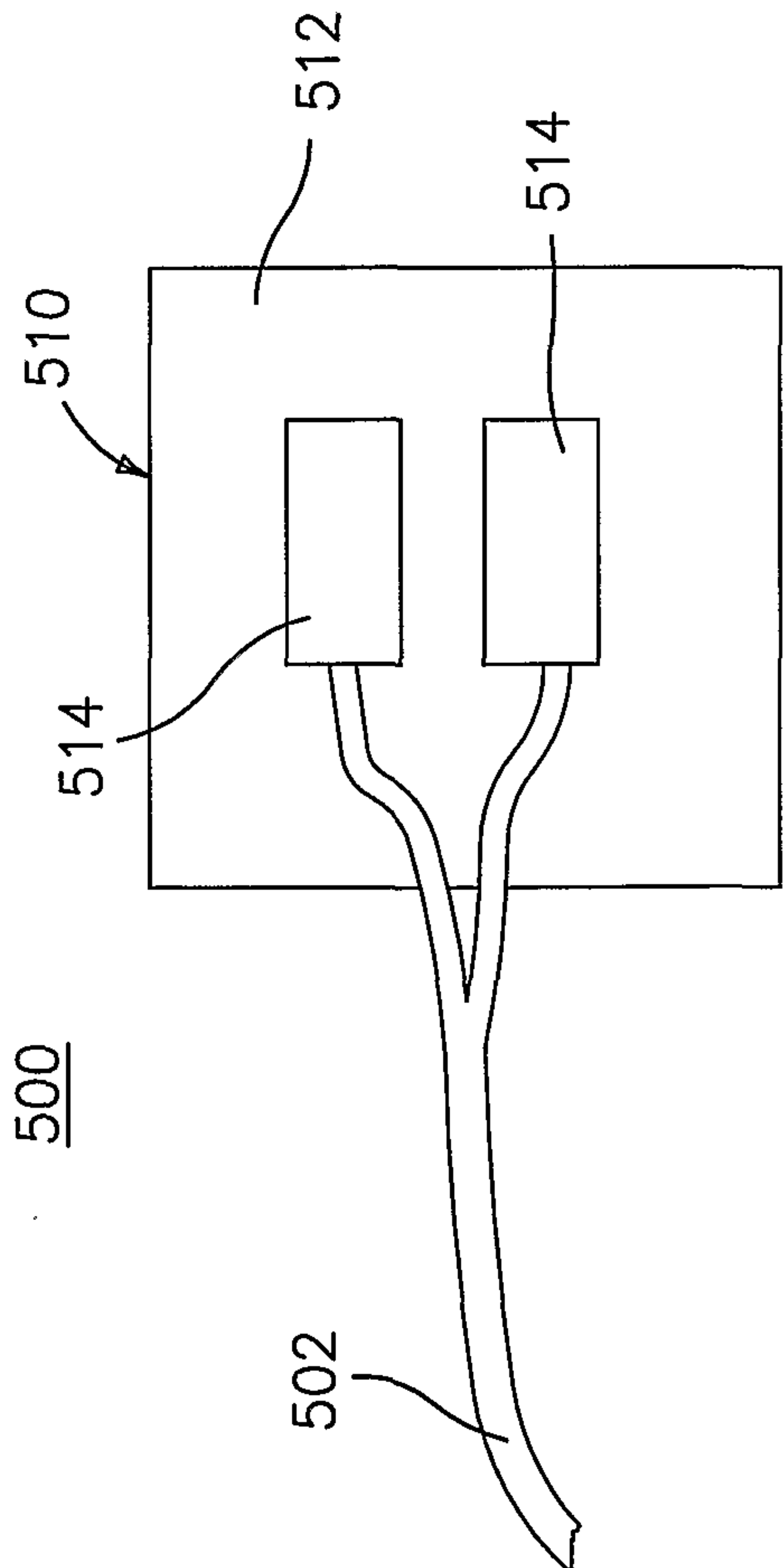

FIG. 8

