



(22) Date de dépôt/Filing Date: 2012/05/18
(41) Mise à la disp. pub./Open to Public Insp.: 2013/11/18
(45) Date de délivrance/Issue Date: 2018/04/17

(51) Cl.Int./Int.Cl. *A63B 71/08* (2006.01),
A41D 13/015 (2006.01), *A41D 13/05* (2006.01),
A63B 71/12 (2006.01)

(72) Inventeurs/Inventors:
CONTANT, MATHIEU, CA;
BEAUREGARD, MARCO, CA;
GENEREUX, MARIE-CLAUDE, CA;
LEBLANC, ALEXANDRE, CA

(73) Propriétaire/Owner:
BAUER HOCKEY LTD., CA

(74) Agent: SMART & BIGGAR

(54) Titre : VETEMENT DE SPORT PROTECTEUR
(54) Title: PROTECTIVE ATHLETIC GARMENT

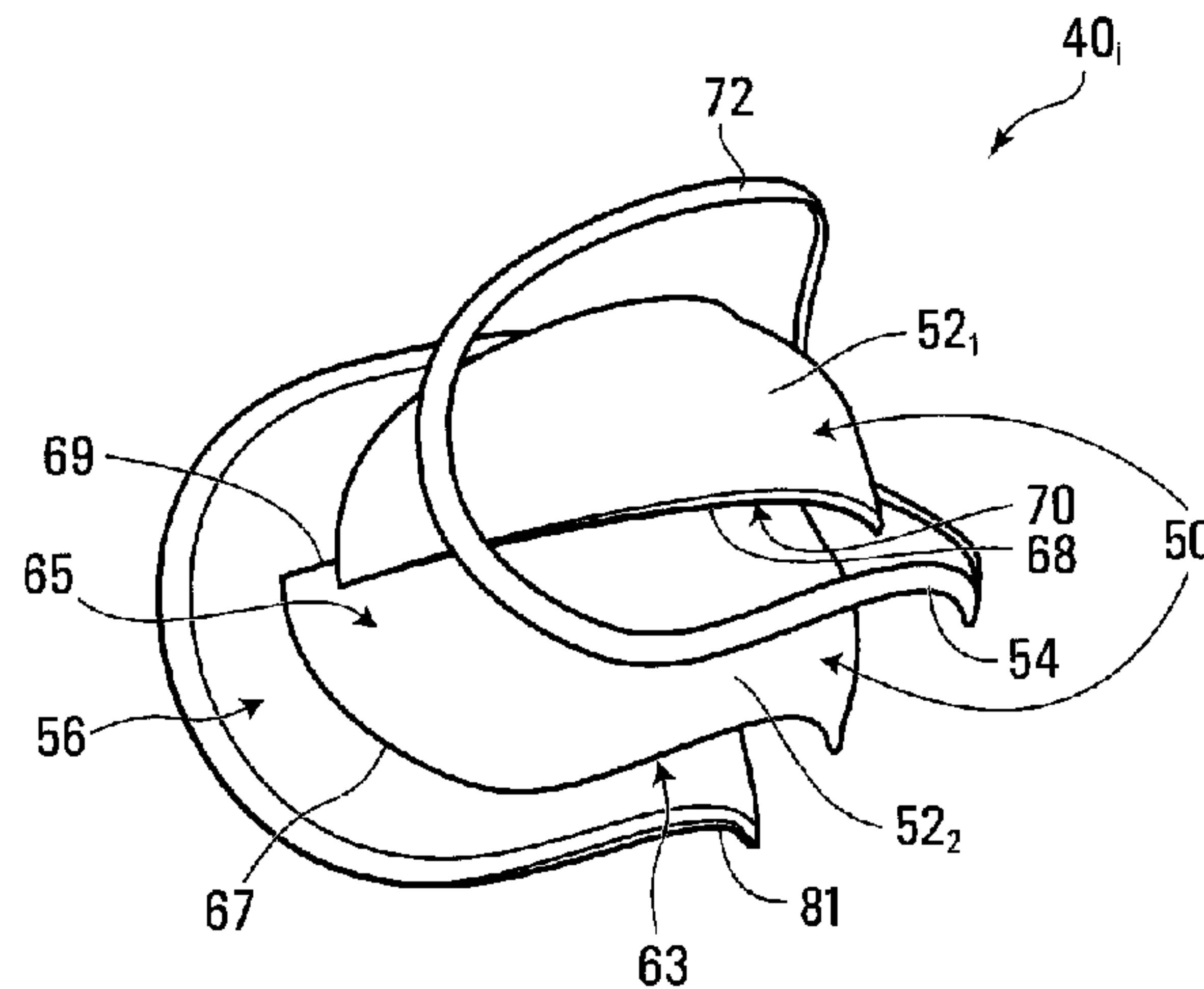

(57) **Abrégé/Abstract:**

A protective athletic garment (e.g., shoulder pads, an elbow pad, or a leg pad) wearable by a user is provided. The protective athletic garment comprises a protective cap (e.g., a shoulder cap, an elbow cap, or a knee cap) for protecting a body part (e.g., a shoulder, an elbow, or a knee) of the user. The protective cap comprises a shell for overlying the user's body part. The shell comprises a first shell member and a second shell member. The protective cap comprises a liner mounted under the shell for being disposed between the shell and the user's body part. The protective cap also comprises a link interconnecting the first shell member and the second shell member to hold the first shell member and the second shell member together. The link extends along at least part of a periphery of the first shell member and at least part of a periphery of the second shell member such that the first shell member and the second shell member are movable relative to one another in response to movement of the user's body part.

ABSTRACT

A protective athletic garment (e.g., shoulder pads, an elbow pad, or a leg pad) wearable by a user is provided. The protective athletic garment comprises a protective cap (e.g., a shoulder cap, an elbow cap, or a knee cap) for protecting a body part (e.g., a shoulder, an elbow, or a knee) of the user. The protective cap comprises a shell for overlying the user's body part. The shell comprises a first shell member and a second shell member. The protective cap comprises a liner mounted under the shell for being disposed between the shell and the user's body part. The protective cap also comprises a link interconnecting the first shell member and the second shell member to hold the first shell member and the second shell member together. The link extends along at least part of a periphery of the first shell member and at least part of a periphery of the second shell member such that the first shell member and the second shell member are movable relative to one another in response to movement of the user's body part.

PROTECTIVE ATHLETIC GARMENT

FIELD OF THE INVENTION

5

The invention relates generally to protective athletic equipment and, more particularly, to protective caps of protective athletic garments such as shoulder pads, elbow pads, and leg pads.

10

BACKGROUND

15

Shoulder pads are worn by players of contact sports, such as hockey, lacrosse and football, for upper body protection. The shoulder pads typically comprise front and back portions for respectively protecting front and back regions of a player's thorax and left and right shoulder protectors for respectively protecting the player's left and right shoulders.

25

Each shoulder protector usually comprises a protective cap, referred to as a "shoulder cap", which includes a shell of rigid material (e.g., polycarbonate or other rigid plastic) for protecting at least part of the player's shoulder. While the shell's rigidity can improve protection of the player's shoulder, it can often restrict or otherwise adversely affect freedom of movement of the player's shoulder. For instance, the shell of the shoulder cap normally overlies an acromioclavicular joint region of the player's shoulder and its rigidity can impede movement at this joint region as the player's moves his/her arm.

30

Similar issues can be encountered with protective caps of various other types of protective athletic garments, such as leg pads and elbow pads, worn by individuals involved in athletic activities to protect their body.

For these and other reasons, there is a need for improvements in protective caps of protective athletic garments.

SUMMARY OF THE INVENTION

5

According to a broad aspect, the invention provides a protective athletic garment wearable by a user, the protective athletic garment comprising a protective cap for protecting a body part comprising an articulation of the user, the protective cap comprising: a shell for overlying the user's articulation, the shell comprising a first shell member and a second shell member that are disposed to overlie the user's articulation; a liner mounted under the shell for being disposed between the shell and the user's articulation; and a link interconnecting the first shell member and the second shell member to hold the first shell member and the second shell member together, the link extending along at least part of a periphery of the first shell member and at least part of a periphery of the second shell member such that the first shell member and the second shell member are movable relative to one another and relative to the liner in response to movement of the user's articulation, wherein each of the first shell member and the second shell member comprises an inner side for facing towards the user's articulation and an outer side for facing away from the user's articulation and wherein the liner is spaced apart from the inner side of the first shell member and the inner side of the second shell member; and wherein each of the first shell member and the second shell member comprises a peripheral edge defined between its inner side and its outer side and wherein the link covers the inner side, the outer side and the peripheral edge of the first shell member and covers the inner side, the outer side and the peripheral edge of the second shell member.

According to another aspect, the invention provides a protective athletic garment wearable by a user, the protective athletic garment comprising a protective cap for protecting a body part comprising an articulation of the user, the protective cap comprising: a shell for overlying the user's articulation, the shell comprising a

30

first shell member and a second shell member, wherein each of the first shell member and the second shell member comprises an inner side for facing towards the user's articulation, an outer side opposite the inner side and for facing away from the user's articulation, and a peripheral edge defined between
5 the inner side and the outer side; a liner mounted under the shell for being disposed between the shell and the user's articulation; and a band interconnecting the first shell member and the second shell member to hold the first shell member and the second shell member together, the band extending along at least part of a periphery of the first shell member and at least part of a
10 periphery of the second shell member such that the first shell member and the second shell member are movable relative to one another in response to movement of the user's articulation, and wherein the band covers the inner side, the outer side and the peripheral edge of the first shell member and covers the inner side, the outer side and the peripheral edge of the second shell member.

15 According to a further aspect, the invention provides athletic shoulder pads wearable by a user, the athletic shoulder pads comprising: a front portion for covering at least part of a front side of a thorax of the user; a back portion for covering at least part of a back side of the thorax of the user; left and right
20 shoulder arch portions for respectively arching over left and right shoulders of the user and interconnecting the front portion and said back portion; left and right shoulder caps mounted above the left and right shoulder arch portions for respectively protecting the left and right shoulders of the player, each of the left and right shoulder caps comprising: a shell for overlying a respective one of the
25 left and right shoulders of the user, the shell comprising a first shell member and a second shell member that are disposed to overlie the respective one of the

left and right shoulders of the user; a liner mounted under the shell for being disposed between the shell and the respective one of the left and right shoulders of the user; and a link interconnecting the first shell member and the second shell member to hold the first shell member and the second shell member together, 5 the link extending along at least part of a periphery of the first shell member and at least part of a periphery of the second shell member such that the first shell member and the second shell member are movable relative to one another and relative to the liner in response to movement of the respective one of the left and right shoulders of the user wherein each of the first shell member and the second 10 shell member comprises a peripheral edge defined between its inner side and its outer side and wherein the link covers the inner side, the outer side and the peripheral edge of the first shell member and covers the inner side, the outer side and the peripheral edge of the second shell member.

15 According to a further aspect, the invention may provide a protective athletic garment wearable by a user, the protective athletic garment comprising a protective cap for protecting a body part comprising an articulation of the user, the protective cap comprising: a shell for overlying the user's articulation, the shell comprising a first shell member and a second shell member that are 20 disposed to overlie the user's articulation; a liner mounted under the shell for being disposed between the shell and the user's articulation; and a link interconnecting the first shell member and the second shell member to hold the first shell member and the second shell member together, wherein the second shell member is movable relative to the first shell member between an extended 25 position when the articulation is in a rest position and a retracted position when the articulation moves out of the rest position.

These and other aspects of the invention will now become apparent to those of ordinary skill in the art upon review of the following description of embodiments of 30 the invention in conjunction with the accompanying drawings.

BRIEF DESCRIPTION OF THE DRAWINGS

A detailed description of embodiments of the invention is provided below, by way of example only, with reference to the accompanying drawings, in which:

5

Figure 1 shows a front view of an example of shoulder pads for upper body protection of a user which comprise protective caps in accordance with an embodiment of the invention;

10 Figure 2 shows a rear view of the shoulder pads;

Figure 3 shows a front view of a protective cap of the shoulder pads;

Figure 4 shows a rear view of the protective cap;

Figure 5 shows an exploded view of the protective cap;

5 Figure 6 shows a cross-sectional view of the protective cap;

Figure 7 shows a cross-sectional view of part of a shell member of a shell of the protective cap;

10 Figure 8 shows a cross-sectional view of part of a liner of the protective cap;

Figures 9A and 9B show examples of movement of two shell members of the shell of the protective cap relative to one another;

15 Figure 10 shows a cross-sectional view of part of a shell member of a shell of the protective cap in accordance with another embodiment of the invention; and

Figures 11A and 11B show front and back views of regions of an upper body of the user.

20

It is to be expressly understood that the description and drawings are only for the purpose of illustrating certain embodiments of the invention and are an aid for understanding. They are not intended to be a definition of the limits of the invention.

25

DETAILED DESCRIPTION OF EMBODIMENTS

Figures 1 and 2 show an example of a protective athletic garment 10 wearable by a user in accordance with an embodiment of the invention. The protective athletic garment 10 is protective athletic equipment wearable by the user when
30 playing a sport or performing another athletic activity to protect his/her body

against injury. In this embodiment, the protective athletic garment 10 is shoulder pads for upper body protection of the user. More particularly, in this embodiment, the user is a hockey player playing hockey such that the shoulder pads 10 are hockey shoulder pads.

5

The shoulder pads 10 protect various regions of an upper body of the player. As shown in Figures 11A and 11B, a thorax 12 of the player has a front side FS and a back side BS. The front side FS of the thorax 12, which can also be referred to as a "chest" or "ventral" side, comprises left and right pectoral regions LPR, RPR overlying left and right pectoral muscles of the player and a sternum region SR overlying a sternum of the player. The back side BS of the thorax 12, which can also be referred to as a "dorsal" side, comprises a thoracic spinal region TSR overlying thoracic vertebrae of the player, left and right trapezius regions LTR, RTR overlying left and right trapezius muscles of the player, and left and right latissimus dorsi regions LLR, RLR overlying left and right latissimus dorsi muscles of the player. Left and right left shoulders 20₁, 20₂ of the player join left and right arms 24₁, 24₂ of the player to the thorax 12. Each of the left and right shoulders 20₁, 20₂ has a clavicle region CR, a scapular region BR, an acromioclavicular joint region ACR, and a deltoid region DR respectively overlying a clavicle, a scapula, an acromioclavicular joint, and a deltoid muscle of that shoulder. The upper body of the player has a front-back (i.e., a dorso-ventral) axis FBA (which is perpendicular to the front and back views shown in Figures 11A and 11B), a left-right (i.e., dextro-sinistral) axis LRA, and a vertical (i.e., cephalo-caudal) axis VA.

25

The shoulder pads 10 comprise a front portion 30, a back portion 32, left and right shoulder arch portions 34₁, 34₂, and left and right shoulder protectors 38₁, 38₂. A front-back direction, a left-right direction, and a top-bottom direction of the shoulder pads 10 are respectively parallel to the front-back axis FBA, the left-right axis LRA, and the vertical axis VA of the upper body of the player. The front portion 30, the back portion 32, and the left and right shoulder arch portions 34₁,

30

34₂ define a neck opening 39 for receiving a neck of the player. In this embodiment, the shoulder pads 10 also comprise left and right arm protectors 21₁, 21₂ and left and right lower straps 44₁, 44₂.

- 5 The left and right shoulder protectors 38₁, 38₂ comprise protective caps 40₁, 40₂, which can be referred to as “shoulder caps”. As further discussed later, the shoulder caps 40₁, 40₂ are configured to facilitate movement of the left and right shoulders 20₁, 20₂ of the player when the player moves his/her left and right arms 24₁, 24₂.

10

The front portion 30 is configured to cover at least part of the front side FS of the thorax 12 of the player. In this embodiment, the front portion 30, which can also be referred to as a front “panel”, comprises left and right pectoral portions 42₁, 42₂ for covering the left and right pectoral regions LPR, RPR of the player and a
 15 sternum portion 46 for covering the sternum region SR of the player. The front portion 30 comprises a top edge 25 delimiting the neck opening 39.

In this embodiment, the front portion 30 comprises protective padding 48 disposed between an inner liner 51 and an outer covering 55. The protective
 20 padding 48 provides padded protection to the left and right pectoral regions LPR, RPR and the sternum region SR of the player. The protective padding 48 may comprise any suitable shock-absorbing material. For instance, in some examples of implementation, the protective padding 48 may comprise foam, such as
 25 ethylene vinyl acetate (EVA) foam, expanded polypropylene (EPP) foam, expanded polyethylene (EPE) foam (e.g., low-density polyethylene (LDPE) foam), vinyl nitrile (VN) foam, or any other suitable foam, and/or may comprise shock-absorbing material other than foam (e.g., a gel in the sternum portion 46 for providing added protection to the sternum region SR of the player).

30 The inner liner 51 faces the thorax 12 of the player and comprises fabric. For instance, in some examples of implementation, the fabric of the inner liner 51

may comprise a woven fabric, a nonwoven fabric, synthetic microfibers, a synthetic woven knit, a polyurethane laminate, a mesh, or any other suitable fabric. The outer covering 55 faces away from the thorax 12 of the player and may comprise any suitable material. For instance, in some examples of
5 implementation, the outer covering 55 may comprise a shell of rigid material (e.g., one or more shell pieces of polycarbonate or other rigid polymeric material) and/or flexible non-foam polymeric material (e.g., polyurethane).

The front portion 30 may be implemented in various other ways in other
10 embodiments. For example, in other embodiments, the front portion 30 may have various other shapes, comprise various other components, and/or be made of various other materials.

The back portion 32 is configured to cover at least part of the back side BS of the
15 thorax 12 of the player. In this embodiment, the back portion 32, which can also be referred to as a back "panel", comprises a spinal portion 73 for covering the thoracic spinal region TSR of the player 14, left and right trapezius portions 74₁, 74₂ for covering the left and right trapezius regions LTR, RTR of the player, and left and right latissimus dorsi portions 76₁, 76₂ for covering the left and right
20 latissimus dorsi regions LLR, RLR of the player. The back portion 32 comprises a top edge 78 delimiting the neck opening 39.

In this embodiment, the back portion 32 comprises protective padding 82 disposed between an inner liner 85 and an outer covering 86. The protective
25 padding 82 provides padded protection to the thoracic spinal region SR, the left and right trapezius regions LTR, RTR, and left and right latissimus dorsi regions LLR, RLR of the player. The inner liner 85 faces the thorax 12 of the player, while the outer covering 86 faces away from the thorax 12 of the player. In this example of implementation, these components of the back portion 32 are similar
30 in construction to the protective padding 48, the inner liner 51, and the outer covering 55 of the front portion 30.

The back portion 32 may be implemented in various other ways in other embodiments. For example, in other embodiments, the back portion 32 may have various other shapes, comprise various other components, and/or be made of various other materials.

The left and right shoulder arch portions 34₁, 34₂ are configured to respectively arch over the left and right shoulders 20₁, 20₂ of the player and interconnect the front portion 30 and the back portion 32. Each shoulder arch portion 34_x comprises a clavicle portion 53 and a scapular portion 84 for respectively overlying the clavicle region CR and the scapular region BR of the shoulder 20_x over which it arches.

In this embodiment, the shoulder arch portion 34_x comprises protective padding 60 disposed between an inner liner 62 and an outer covering 63. The protective padding 60 provides padded protection to the clavicle region CR and the scapular region BR of the shoulder 20_x. The inner liner 62 faces the shoulder 20_x, while the outer covering 63 faces away from the shoulder 20_x. In this example of implementation, these components of the shoulder arch portion 34_x are similar in construction to the protective padding 48, the inner liner 51, and the outer covering 55 of the front portion 30.

The left and right shoulder arch portions 34₁, 34₂ may be implemented in various other ways in other embodiments. For example, in other embodiments, each of the left and right shoulder arch portions 34₁, 34₂ may have various other shapes, comprise various other components, and/or be made of various other materials.

The left and right shoulder protectors 38₁, 38₂, which comprise the shoulder caps 40₁, 40₂, are configured to respectively cover at least part of the left and right shoulders 20₁, 20₂ of the player. In this embodiment, each of the shoulder caps 40₁, 40₂ comprises an acromioclavicular joint portion 41 and a deltoid portion 43

for respectively covering at least part of the acromioclavicular joint region ACR and the deltoid region DR of the shoulder it protects.

Each of the left and right shoulder protectors 38₁, 38₂ is connected to at least one
 5 of the front portion 30, the back portion 32, and a given one of the left and right
 shoulder arch portions 34₁, 34₂. In this embodiment, each shoulder cap 40_x is
 connected to the shoulder arch portion 34_x arching over the shoulder 20_x that it
 protects. Also, in this embodiment, the shoulder cap 40_x is connected to the arm
 protector 21_x which is on the arm 24_x extending from the shoulder 20_x it protects.
 10 The shoulder cap 40_x may be directly connected (e.g., sewed) to the shoulder
 arch portion 34_x and/or the arm protector 21_x or may be indirectly connected
 (e.g., via one or more straps sewed) to the shoulder arch portion 34_x and/or the
 arm protector 21_x. In this example, the shoulder cap 40_x is sewed to the shoulder
 arch portion 34_x and is connected via a strap to the arm protector 21_x.

15

The left and right arm protectors 21₁, 21₂ are configured to cover at least part of
 the left and right arms 24₁, 24₂ of the player. Each arm protector 21_x comprises
 an outer arm portion 27 for overlying an outer region of the arm 24_x it protects
 and a strap 28 for retaining itself on the arm 24_x.

20

In this embodiment, the arm protector 21_x comprises protective padding 57
 disposed between an inner liner 72 and an outer covering 79. The protective
 padding 57 provides padded protection to the outer region of the arm 24_x. The
 inner liner 72 faces the arm 24_x, while the outer covering 63 faces away from the
 25 arm 24_x. In this example of implementation, these components of the arm
 protector 21_x are similar in construction to the protective padding 48, the inner
 liner 51, and the outer covering 55 of the front portion 30.

The left and right arm protectors 21₁, 21₂ may be implemented in various other
 30 ways in other embodiments. For example, in other embodiments, each of the left

and right arm protectors 21₁, 21₂ may have various other shapes, comprise various other components, and/or be made of various other materials.

With additional reference to Figures 3 to 8, each shoulder cap 40_x comprises a
5 shell 50 for overlying the player's shoulder 20_x that it protects. The shell 50
comprises a first shell member 52₁ and a second shell member 52₂. The
shoulder cap 40_x also comprises a link 54 interconnecting the shell members 52₁,
52₂ to hold the shell members 52₁, 52₂ together. The link 54 extends along at
10 least part of a periphery of the first shell member 52₁ and at least part of a
periphery of the second shell member 52₂ such that the shell members 52₁, 52₂
are movable relative to one another in response to movement of the shoulder 20_x
of the player. The shoulder cap 40_x also comprises a liner 56 mounted under the
shell 50 to be disposed between the shell 50 and the shoulder 20_x of the player.
In this embodiment, the shell 50 and the liner 56 are connected to one another
15 through the link 54.

The ability of the shell members 52₁, 52₂ to move relative to one another can
facilitate movement of the player's shoulder 20_x when he/she moves (e.g., raises)
his/her arm 24_x). More particularly, in this embodiment, the second shell member
20 52₂ is movable relative to the first shell member 52₁ between an extended
position and a retracted position, examples of which are shown in Figures 9A and
9B. When the second shell member 52₂ is in the retraction position (Figure 9B),
the shell members 52₁, 52₂ overlap. When the second shell member 52₂ is in the
extended position (Figure 9A), the shell members 52₁, 52₂ are positioned relative
25 to one another to avoid a gap therebetween through which the shoulder 20_x of
the player could be impacted. In this example of implementation, the shell
members 52₁, 52₂ overlap when the second shell member 52₂ is in the extended
position. An overlap of the shell members 52₁, 52₂ when the second shell
member 52₂ is in the retracted position, as shown in Figure 9B, is greater than an
30 overlap of the shell members 52₁, 52₂ when the second shell member 52₂ is in
the extended position, as shown in Figure 9A. The overlap of the shell members

52₁, 52₂ in each of the retracted position and the extended position can be taken as a distance between a portion 68 of the peripheral edge 67 of the first shell member 52₁ that overlaps the second shell member 52₂ and a portion 69 of the peripheral edge 67 of the second shell member 52₂ that overlaps the first shell member 52₁ measured along a direction of motion of the second shell member 52₂ relative to the first shell member 52₁. For example, in some embodiments, the overlap of the shell members 52₁, 52₂ when the second shell member 52₂ is in the retracted position (Figure 7B) may be at least 10%, in some cases at least 20%, and in some cases at least 30% or more (e.g., 50%) greater than the overlap of the shell members 52₁, 52₂ when the second shell member 52₂ is in the extended position. In other examples of implementation, the shell members 52₁, 52₂ may not overlap when the second shell member 52₂ is in the extended position, but may rather be close enough to avoid a gap therebetween that would expose the player's shoulder 20_x to an impact through such gap.

15

Therefore, in this embodiment, when the player's shoulder 20_x moves as the player's arm 24_x moves upwardly, the second shell member 52₂ can pivot medially (i.e., in a direction towards a medial (midsagittal) plane of the player's body) relative to the first shell member 52₁. This is represented by an arrow in Figure 9A indicating a direction of movement of the second shell member 52₂ relative to the first shell member 52₁ such that the second shell member 52₂ moves from the extended position shown in Figure 9A towards the retracted position shown in Figure 9B. Conversely, when the player's shoulder 20_x moves as the player's arm 24_x moves downwardly, the second shell member 52₂ can pivot laterally (i.e., in a direction away from the medial (midsagittal) plane of the player's body) relative to the first shell member 52₁. This would be a movement of the second shell member 52₂ in a direction opposite to the arrow in Figure 9A.

Accordingly, while the rigidity of the shell 50 of the shoulder cap 40_x provides proper protection of the player's shoulder 20_x, the ability of the shell members

30

52₁, 52₂ to move relative to one another facilitates movement of the player's shoulder 20_x.

Each shell member 52_i of the shell 50 of the shoulder cap 40_x is rigid and has an inner side 63 facing towards the shoulder 20_x, an outer side 65 opposite the inner side 63 and facing away from the shoulder 20_x, and a peripheral edge 67 between the inner side 63 and the outer side 65. In this example of implementation, the shell member 52_i is curved such that its inner and outer sides 63, 65 are curved. More particularly, in this example, the shell member 52_i is curved in two orthogonal directions such that its inner side 63 is generally concave and its outer side 65 is generally convex.

In this embodiment, the shell member 52_i comprises a rigid core 58 and a fabric layer 60 covering at least part of the rigid core 58. More particularly, in this embodiment, the fabric layer 60 overlies an outer surface of the rigid core 58 such that it forms at least part of the outer side 65 of the shell member 52_i. The rigid core 58 and the fabric layer 60 may be made of any suitable material. For example, in some embodiments, the rigid core 58 may comprise polycarbonate, high-density polyethylene (HDPE), polypropylene, polyurethane, or any other rigid polymeric material or any other suitably rigid material. The fabric layer 60 may comprise a woven fabric (e.g., a woven polyester or nylon fabric), a nonwoven fabric, synthetic microfibers, a synthetic woven knit, a polyurethane laminate, a mesh, or any other suitable fabric.

The shell 50 may be implemented in various other ways in other embodiments. For example, in other embodiments, the shell members 52₁, 52₂ may have various other shapes and/or be made of various other materials. For instance, Figure 10 illustrates another embodiment in which the shell member 52₂ includes a projection 96 which can be engaged by the shell member 52₁ as the shell members 52₁, 52₂ move relative to one another to limit this relative movement.

The link 54 may extend along any suitable extent of the shell 50 to interconnect and hold together the shell members 52₁, 52₂. In this embodiment, the link 54 extends along at least a majority of a perimeter of the shell 50. More particularly, in this embodiment, the link 54 extends along an entirety of the perimeter of the shell 50 such that it surrounds the shell 50. Also, in this embodiment, the link 54 overlies the inner side 63, the outer side 65 and the peripheral edge 67 of the first shell member 52₁ and the inner side 63, the outer side 65 and the peripheral edge 67 of the second shell member 52₂.

10 In this example of implementation, the link 54 extends along a majority of the peripheral edge 67 of the first shell member 52₁ and a majority of the peripheral edge 67 of the second shell member 52₂. More particularly, in this example, the link 54 extends along all the peripheral edge 67 of the first shell member 52₁ except along a portion 68 of the peripheral edge 67 of the first shell member 52₁ that overlaps the second shell member 52₂ when the second shell member 52₂ is in the retracted position. Similarly, the link 54 extends along all the peripheral edge 67 of the second shell member 52₂ except along a portion 69 of the peripheral edge 67 of the second shell member 52₂ that overlaps the first shell member 52₁ when the second shell member 52₂ is in the retracted position. In other words, each of the portion 68 of the peripheral edge 67 of the first shell member 52₁ and the portion 69 of the peripheral edge 67 of the second shell member 52₂ is free of the link 54. This creates a space 70 between the shell members 52₁, 52₂ allowing them to move relative to another when the shoulder 20_x of the player moves.

25 In this embodiment, the link 54 comprises a connecting band 72. More particularly, in this embodiment, the connecting band 72 is a connecting strip of fabric. In this example, the strip of fabric constituting the connecting band 72 is a braiding. For instance, in some examples of implementation, the strip of fabric constituting the connecting band 72 may comprise a woven polyester fabric, a woven nylon fabric, or any other suitable textile. The connecting band 72 may be

made of any other suitable material in other examples of implementation (e.g., polyurethane, rubber or another elastomer, spandex, etc.).

The link 54 can be affixed to the shell members 52₁, 52₂ in various ways. In this embodiment, the link 54 is affixed to the shell members 52₁, 52₂ by a stitching 71. More particularly, the stitching 71 extends through the link 54 and each shell member 52_i to affix the link 54 to the shell member 52_i. The stitching 71 may extend along a majority of the perimeter of the shell 50. In this example, the stitching 71 surrounds the shell 50. In other embodiments, the link 54 may be affixed to the shell members 52₁, 52₂ by staples, an adhesive, or any other suitable affixing means.

The link 54 may be implemented in various other ways in other embodiments. For example, in other embodiments, the link 54 may have various other shapes and/or be made of various other materials.

The liner 56 is flexible. In this embodiment, the liner 56 comprises a flexible core 75 and a fabric layer 77 covering at least part of the flexible core 75. More particularly, in this embodiment, the fabric layer 77 overlies inner and outer surfaces of the flexible core 75. The flexible core 75 and the fabric layer 77 may be made of any suitable material. For example, in some embodiments, the flexible core 75 may comprise foam, such as low-density polyethylene (LDPE) foam, polyurethane foam, EVA foam, VN foam, or any other suitable foam. The fabric layer 77 may comprise a woven fabric (e.g., a woven polyester or nylon fabric), a nonwoven fabric, synthetic microfibers, a synthetic woven knit, a polyurethane laminate, a mesh, or any other suitable fabric. In this embodiment, the liner 56 also comprises a braiding 81 along its periphery.

A perimeter of the liner 56 is at least as large as the perimeter of the shell 50. In this embodiment, the perimeter of the liner 56 is larger than the perimeter of the shell 50. More particularly, in this embodiment, the shell 50 is disposed generally

concentrically on the liner 56. The perimeter of the shell 50 is disposed within the perimeter of the liner 56 such that the liner 56 includes a margin 83 that is left exposed.

- 5 In this example, the liner 56 is connected to the shoulder arch portion 34_x and the arm protector 21_x, directly or indirectly, in order to connect the shoulder cap 40_x to the shoulder arch portion 34_x and the arm protector 21_x. More particularly, in this example, the liner 56 is sewed to the shoulder arch portion 34_x and is connected to the arm protector 21_x via a strap which is sewed to the liner 56, the
10 shoulder arch portion 34_x and the arm protector 21_x.

The liner 56 may be implemented in various other ways in other embodiments. For example, in other embodiments, the liner 56 may have various other shapes and/or be made of various other materials.

15

The shell 50 can be affixed to the liner 56 in various ways. In this embodiment, the shell 50 is affixed to the liner 56 by a stitching 80. In this example, the stitching 80 extends through the link 54 which interconnects the shell members 52₁, 52₂ and through the liner 56. The stitching 80 may extend along all or less
20 than all of the perimeter of the shell 50. In this example, the stitching 80 extends along all of a proximal side, a front side and a back side of the perimeter of the shell 50 and along part but not all of a distal side of the perimeter of the shell 50 such that a portion 87 of the perimeter of the shell 50 is free from attachment to the liner 56. In other embodiments, the shell 50 may be affixed to the liner 56 by
25 the stitching 78 which fixes the link 54 to the shell members 52₁, 52₂. In other words, the stitching 78 may extend through the shell members 52₁, 52₂, the link 54 and the liner 56. In other embodiments, the shell 50 may be affixed to the liner 56 by staples, an adhesive, or any other suitable affixing means.

- 30 Flexibility of the liner 56 may facilitate motion of the shell members 52₁, 52₂ relative to one another since the shell 50 and the liner 56 are interconnected

through the link 54 in this embodiment. For example, in this embodiment, when the shell member 52₂ moves relative to the shell member 52₁ towards its retracted position, a portion of the liner 56 through which extends a portion of the stitching 80 that also extends through the shell member 52₂ may bend towards the shell member 52₁ to facilitate motion of the shell member 52₂. Conversely, when the shell member 52₂ moves relative to the shell member 52₁ towards its extended position, the portion of the liner 56 through which extends the portion of the stitching 80 that also extends through the shell member 52₂ may bend away from the shell member 52₁ to facilitate motion of the shell member 52₂.

10

In this embodiment, the shoulder cap 40_x comprises a restraint 85 interconnecting the shell members 52₁, 52₂ to restrain movement of the second shell member 52₂ relative to the first shell member 52₁. In this example of implementation, the restraint 85 is implemented as a tether which is a strap that is connected (e.g., sewed) to the shell members 52₁, 52₂ on their respective inner side 63.

15

More particularly, in this embodiment, the restraint 85 is configured to prevent the second shell member 52₂ from moving from a given one of the inner side 63 and the outer side 65 of the first shell member 52₁ to an opposite one of the inner side 63 and the outer side 65 of the first shell member 52₁, in this case from the inner side 63 to the outer side 65 of the first shell member 52₁. The restraint 85 prevents the peripheral edge 67 of the second shell member 52₂ to move over the peripheral edge 67 of the first shell member 52₁ and onto the outer side 65 of the first shell member 52₁ when the second shell member 52₂ pivots laterally (i.e., in a direction away from the medial (midsagittal) plane of the player's body).

20

25

The restraint 85 may be implemented in various other ways in other embodiments. For example, in other embodiments, the restraint 85 may have various other shapes and/or be made of various other materials.

30

The shoulder caps 40₁, 40₂ may be implemented in various other ways in other embodiments. For example, in other embodiments, each of the shoulder caps 40₁, 40₂ may have various other shapes, comprise various other components, and/or be made of various other materials.

5

While in this embodiment the shoulder pads 10 are hockey shoulder pads, in other embodiments, shoulder pads constructed using principles described herein in respect of the shoulder pads 10, including the protective caps 40₁, 40₂, may be another type of shoulder pads for upper body protection of a player playing another type of contact sport (sometimes referred to as “full-contact sport” or “collision sport”) in which there are significant impact forces on the player due to player-to-player and/or player-to-object contact. For example, in other embodiments, shoulder pads constructed using principles described herein in respect of the shoulder pads 10 may be lacrosse shoulder pads for upper body protection of a lacrosse player. As another example, in other embodiments, shoulder pads constructed using principles described herein in respect of the shoulder pads 10 may be football shoulder pads for upper body protection of a football player.

Although in embodiments considered above the shoulder pads 10 are a protective athletic garment for a user playing a contact sport, a protective athletic garment constructed using principles described herein in respect of the shoulder pads 10, including the protective caps 40₁, 40₂, may be used in athletic activities other than contact sports in which protection against body injury is desired.

25

While in this embodiment the protective caps 40₁, 40₂ are part of shoulder pads, a protective cap constructed using principles described herein in respect of the protective caps 40₁, 40₂ may be used in other types of protective athletic garments. For example, in other embodiments, a protective cap constructed using principles described herein in respect of the protective caps 40₁, 40₂ may be a knee cap of a leg pad or an elbow cap of an elbow pad worn by a user in

30

order to protect a knee or an elbow of the user. A protective cap constructed using principles described herein in respect of the protective caps 40₁, 40₂ may be used to protect any articulation of the user while facilitating movement of that articulation.

5

To facilitate the description, any reference numeral designating an element in one figure has been used to designate the same element if used in any other figures. In describing the embodiments, specific terminology has been resorted to for the sake of clarity but the invention is not intended to be limited to the specific terms so selected, and it is understood that each specific term comprises all
10 equivalents.

Unless otherwise indicated, the drawings are intended to be read together with the specification, and are to be considered a portion of the entire written
15 description of this invention. Unless otherwise indicated, the terms "horizontal", "vertical", "left", "right", "up", "down" and the like, as well as adjectival and adverbial derivatives thereof (e.g., "horizontally", "rightwardly", "upwardly", "radially", etc.), simply refer to the orientation of the illustrated structure.

20 Although various embodiments and examples have been presented, this was for the purpose of describing, but not limiting, the invention. Various modifications and enhancements will become apparent to those of ordinary skill in the art and are within the scope of the invention, which is defined by the appended claims.

CLAIMS

1. A protective athletic garment wearable by a user, the protective athletic garment comprising a protective cap for protecting a body part comprising an articulation of the user, the protective cap comprising:
 - a) a shell for overlying the user's articulation, the shell comprising a first shell member and a second shell member that are disposed to overlie the user's articulation;
 - b) a liner mounted under the shell for being disposed between the shell and the user's articulation; and
 - c) a link interconnecting the first shell member and the second shell member to hold the first shell member and the second shell member together, the link extending along at least part of a periphery of the first shell member and at least part of a periphery of the second shell member such that the first shell member and the second shell member are movable relative to one another and relative to the liner in response to movement of the user's articulation;

wherein each of the first shell member and the second shell member comprises an inner side for facing towards the user's articulation and an outer side for facing away from the user's articulation and wherein the liner is spaced apart from the inner side of the first shell member and the inner side of the second shell member;

wherein each of the first shell member and the second shell member comprises a peripheral edge defined between its inner side and its outer side and wherein the link covers the inner side, the outer side and the peripheral edge of the first shell member and covers the inner side, the outer side and the peripheral edge of the second shell member.
2. The protective athletic garment of claim 1, wherein the second shell member is movable relative to the first shell member between an extended position and a retracted position, the first shell member and the second shell member overlapping when the second shell member is in the retracted position.

3. The protective athletic garment of claim 2, wherein, when the second shell member is in the extended position, the first shell member and the second shell member are positioned to prevent a gap therebetween through which the user's articulation could be impacted.
4. The protective athletic garment of claim 2 or 3, wherein the first shell member and the second shell member overlap when the second shell member is in the extended position, the overlap of the first shell member and the second shell member when the second shell member is in the retracted position being greater than the overlap of the first shell member and the second shell member when the second shell member is in the extended position.
5. The protective athletic garment of any one of claims 1 to 4, wherein the link comprises a strip of fabric.
6. The protective athletic garment of claim 5, wherein the strip of fabric is a braiding.
7. The protective athletic garment of any one of claims 1 to 6, wherein the link extends along at least a majority of a perimeter of the shell.
8. The protective athletic garment of any one of claims 1 to 7, wherein the link surrounds the shell.
9. The protective athletic garment of any one of claims 1 to 8, wherein each of the first and second shell members is curved in two orthogonal directions such that its inner side is generally concave and its outer side is generally convex.
10. The protective athletic garment of claim 9, wherein the shell has a dome shape.
11. The protective athletic garment of any one of claims 1 to 10, wherein the link is affixed to the shell and the liner.

12. The protective athletic garment of claim 11, wherein the link is affixed to the shell and the liner by at least one stitching.
13. The protective athletic garment of any one of claims 1 to 11, wherein the shell is affixed to the liner by a stitching passing through the link.
14. The protective athletic garment of claim 13, wherein the link and the stitching surround the shell.
15. The protective athletic garment of claim 13 or 14, wherein the stitching is a first stitching, the link being affixed to the shell by a second stitching.
16. The protective athletic garment of any one of claims 1 to 15, wherein each of the first shell member and the second shell member comprises a rigid core and a fabric layer covering at least part of the rigid core.
17. The protective athletic garment of any one of claims 1 to 16, wherein the liner comprises a flexible core and a fabric layer covering at least part of the flexible core.
18. The protective athletic garment of any one of claims 1 to 17, comprising a restraint interconnecting the first shell member and the second shell member to restrain movement of the second shell member relative to the first shell member.
19. The protective athletic garment of any one of claims 1 to 18, wherein a perimeter of the liner is larger than a perimeter of the shell.
20. The protective athletic garment of any one of claims 1 to 19, wherein the articulation is located proximate a joint region of a shoulder, a knee cap or an elbow point and wherein the protective cap is a shoulder cap, knee cap or elbow cap with first and second shell members overlying the joint region of the shoulder, knee cap or elbow point.

21. The protective athletic garment of any one of claims 3 to 20 when depending upon claim 2, wherein a portion of a peripheral edge of the first shell member overlaps a portion of a peripheral edge of the second shell member when the second shell member is in the extended or retracted position, the overlapping peripheral edge portions being free of the link.
22. A protective athletic garment wearable by a user, the protective athletic garment comprising a protective cap for protecting a body part comprising an articulation of the user, the protective cap comprising:
 - a) a shell for overlying the user's articulation, the shell comprising a first shell member and a second shell member, wherein each of the first shell member and the second shell member comprises an inner side for facing towards the user's articulation, an outer side opposite the inner side and for facing away from the user's articulation, and a peripheral edge defined between the inner side and the outer side;
 - b) a liner mounted under the shell for being disposed between the shell and the user's articulation; and
 - c) a band interconnecting the first shell member and the second shell member to hold the first shell member and the second shell member together, the band extending along at least part of a periphery of the first shell member and at least part of a periphery of the second shell member such that the first shell member and the second shell member are movable relative to one another in response to movement of the user's articulation, and wherein the band covers the inner side, the outer side and the peripheral edge of the first shell member and covers the inner side, the outer side and the peripheral edge of the second shell member.
23. The protective athletic garment of claim 22, wherein the second shell member is movable relative to the first shell member between an extended position and a retracted position, the first shell member and the second shell member overlapping when the second shell member is in the retracted position.
24. The protective athletic garment of claim 23, wherein, when the second shell member is in the extended position, the first shell member and the second shell member are

positioned to prevent a gap therebetween through which the user's articulation could be impacted.

25. The protective athletic garment of claim 23 or 24, wherein the first shell member and the second shell member overlap when the second shell member is in the extended position, the overlap of the first shell member and the second shell member when the second shell member is in the retracted position being greater than the overlap of the first shell member and the second shell member when the second shell member is in the extended position.
26. The protective athletic garment of any one of claims 22 to 25, wherein the band extends along at least a majority of a perimeter of the shell.
27. The protective athletic garment of any one of claims 22 to 26, wherein the band surrounds the shell.
28. The protective athletic garment of any one of claims 22 to 27, wherein the liner is spaced apart from at least part of the inner side of the first shell member and at least part of the inner side of the second shell member.
29. The protective athletic garment of any one of claims 22 to 28, wherein the articulation is located proximate a joint region of a shoulder, a knee cap or an elbow point and wherein the protective cap is a shoulder cap, knee cap or elbow cap with first and second shell members overlying the joint region of the shoulder, knee cap or elbow point.
30. The protective athletic garment of any one of claims 22 to 29, wherein each of the first and second shell members is curved in two orthogonal directions such that its inner side is generally concave and its outer side is generally convex.
31. The protective athletic garment of claim 30, wherein the shell has a dome shape.

32. The protective athletic garment of any one of claims 22 to 31, wherein the band is affixed to the shell and the liner.
33. The protective athletic garment of claim 32, wherein the band is affixed to the shell and the liner by at least one stitching.
34. The protective athletic garment of any one of claims 22 to 32, wherein the shell is affixed to the liner by a stitching passing through the band.
35. The protective athletic garment of claim 34, wherein the band and the stitching surround the shell.
36. The protective athletic garment of claim 34 or 35, wherein the stitching is a first stitching, the band being affixed to the shell by a second stitching.
37. The protective athletic garment of any one of claims 22 to 36, wherein each of the first shell member and the second shell member comprises a rigid core and a fabric layer covering at least part of the rigid core.
38. The protective athletic garment of any one of claims 22 to 37, wherein the liner comprises a flexible core and a fabric layer covering at least part of the flexible core.
39. The protective athletic garment of any one of claims 22 to 38, comprising a restraint interconnecting the first shell member and the second shell member to restrain movement of the second shell member relative to the first shell member.
40. The protective athletic garment of any one of claims 22 to 39, wherein a perimeter of the liner is larger than a perimeter of the shell.
41. The protective athletic garment of any one of claims 24 to 40 when depending upon claim 25, wherein a portion of a peripheral edge of the first shell member overlaps a portion of a peripheral edge of the second shell member when the second shell

member is in the extended or retracted position, the overlapping peripheral edge portions being free of the band.

42. The protective athletic garment of any one of claims 22 to 41, wherein the first shell member and the second shell member are movable relative to the liner in response to movement of the user's articulation.

43. Athletic shoulder pads wearable by a user, the athletic shoulder pads comprising:

- a) a front portion for covering at least part of a front side of a thorax of the user;
- b) a back portion for covering at least part of a back side of the thorax of the user;
- c) left and right shoulder arch portions for respectively arching over left and right shoulders of the user and interconnecting the front portion and said back portion;
- d) left and right shoulder caps mounted above the left and right shoulder arch portions for respectively protecting the left and right shoulders of the player, each of the left and right shoulder caps comprising:

- i) a shell for overlying a respective one of the left and right shoulders of the user, the shell comprising a first shell member and a second shell member that are disposed to overlie the respective one of the left and right shoulders of the user;
- ii) a liner mounted under the shell for being disposed between the shell and the respective one of the left and right shoulders of the user; and
- iii) a link interconnecting the first shell member and the second shell member to hold the first shell member and the second shell member together, the link extending along at least part of a periphery of the first shell member and at least part of a periphery of the second shell member such that the first shell member and the second shell member are movable relative to one another and relative to the liner in response to movement of the respective one of the left and right shoulders of the user;

wherein each of the first shell member and the second shell member comprises a peripheral edge defined between its inner side and its outer side and wherein the link covers the inner side, the outer side and the peripheral edge of the first shell

member and covers the inner side, the outer side and the peripheral edge of the second shell member.

44. The athletic shoulder pads of claim 43, wherein the second shell member is movable relative to the first shell member between an extended position and a retracted position, the first shell member and the second shell member overlapping when the second shell member is in the retracted position.
45. The athletic shoulder pads of claim 44, wherein, when the second shell member is in the extended position, the first shell member and the second shell member are positioned to prevent a gap therebetween through which the user's articulation could be impacted.
46. The athletic shoulder pads of claim 44 or 45, wherein the first shell member and the second shell member overlap when the second shell member is in the extended position, the overlap of the first shell member and the second shell member when the second shell member is in the retracted position being greater than the overlap of the first shell member and the second shell member when the second shell member is in the extended position.
47. The athletic shoulder pads of any one of claims 43 to 46, wherein the link comprises a strip of fabric.
48. The athletic shoulder pads of claim 47, wherein the strip of fabric is a braiding.
49. The athletic shoulder pads of any one of claims 43 to 48, wherein the link extends along at least a majority of a perimeter of the shell.
50. The athletic shoulder pads of any one of claims 43 to 49, wherein the link surrounds the shell.
51. The athletic shoulder pads of any one of claims 43 to 50, wherein each of the first shell member and the second shell member comprises an inner side for facing

towards the user's articulation and an outer side for facing away from the user's articulation and wherein the liner is spaced apart from the inner side of the first shell member and the inner side of the second shell member.

52. The athletic shoulder pads of claim 51, wherein each of the first and second shell members is curved in two orthogonal directions such that its inner side is generally concave and its outer side is generally convex.
53. The athletic shoulder pads of claim 52, wherein the shell has a dome shape.
54. The athletic shoulder pads of any one of claims 43 to 53, wherein the link is affixed to the shell and the liner.
55. The athletic shoulder pads of claim 54, wherein the link is affixed to the shell and the liner by at least one stitching.
56. The athletic shoulder pads of any one of claims 43 to 54, wherein the shell is affixed to the liner by a stitching passing through the link.
57. The athletic shoulder pads of claim 56, wherein the link and the stitching surround the shell.
58. The athletic shoulder pads of claim 56 or 57, wherein the stitching is a first stitching, the link being affixed to the shell by a second stitching.
59. The athletic shoulder pads of any one of claims 43 to 58, wherein each of the first shell member and the second shell member comprises a rigid core and a fabric layer covering at least part of the rigid core.
60. The athletic shoulder pads of any one of claims 43 to 59, wherein the liner comprises a flexible core and a fabric layer covering at least part of the flexible core.

61. The athletic shoulder pads of any one of claims 43 to 60, comprising a restraint interconnecting the first shell member and the second shell member to restrain movement of the second shell member relative to the first shell member.
62. The athletic shoulder pads of any one of claims 43 to 61, wherein a perimeter of the liner is larger than a perimeter of the shell.
63. The athletic shoulder pads of any one of claims 45 to 62 when depending upon claim 46, wherein a portion of a peripheral edge of the first shell member overlaps a portion of a peripheral edge of the second shell member when the second shell member is in the extended or retracted position, the overlapping peripheral edge portions being free of the link.
64. A protective athletic garment wearable by a user, the protective athletic garment comprising a protective cap for protecting a body part comprising an articulation of the user, the protective cap comprising:
 - a) a shell for overlying the user's articulation, the shell comprising a first shell member and a second shell member that are disposed to overlie the user's articulation;
 - b) a liner mounted under the shell for being disposed between the shell and the user's articulation; and
 - c) means for interconnecting the first shell member and the second shell member to hold the first shell member and the second shell member together, wherein the second shell member is movable relative to the first shell member between an extended position when the articulation is in a rest position and a retracted position when the articulation moves out of the rest position.
65. The protective athletic garment of claim 64, wherein, when the second shell member is in the extended position, the first shell member and the second shell member are positioned to prevent a gap therebetween through which the user's articulation could be impacted.

66. The protective athletic garment of claim 65, wherein the first shell member and the second shell member overlap when the second shell member is in the extended position, an overlap of the first shell member and the second shell member when the second shell member is in the retracted position being greater than the overlap of the first shell member and the second shell member when the second shell member is in the extended position.
67. The protective athletic garment of any one of claims 64 to 66, wherein the means for interconnecting comprises a strip of fabric.
68. The protective athletic garment of any one of claims 64 to 67, wherein the means for interconnecting extends along at least a majority of a perimeter of the shell.
69. The protective athletic garment of any one of claims 64 to 68, wherein the means for interconnecting surrounds the shell.
70. The protective athletic garment of any one of claims 64 to 69, wherein each of the first and second shell members is curved in two orthogonal directions such that its inner side is generally concave and its outer side is generally convex.
71. The protective athletic garment of any one of claims 64 to 70, wherein the shell has a dome shape.
72. The protective athletic garment of any one of claims 64 to 71, wherein the first shell member and the second shell member are affixed to the liner.
73. The protective athletic garment of any one of claims 64 to 72, wherein the means for interconnecting is affixed to the shell and the liner.
74. The protective athletic garment of any one of claims 64 to 73, wherein the articulation is located proximate a joint region of a shoulder, a knee cap or an elbow point and wherein the protective cap is a shoulder cap, knee cap or elbow cap with the first and

second shell members overlying the joint region of the shoulder, knee cap or elbow point.

+

1/8

10

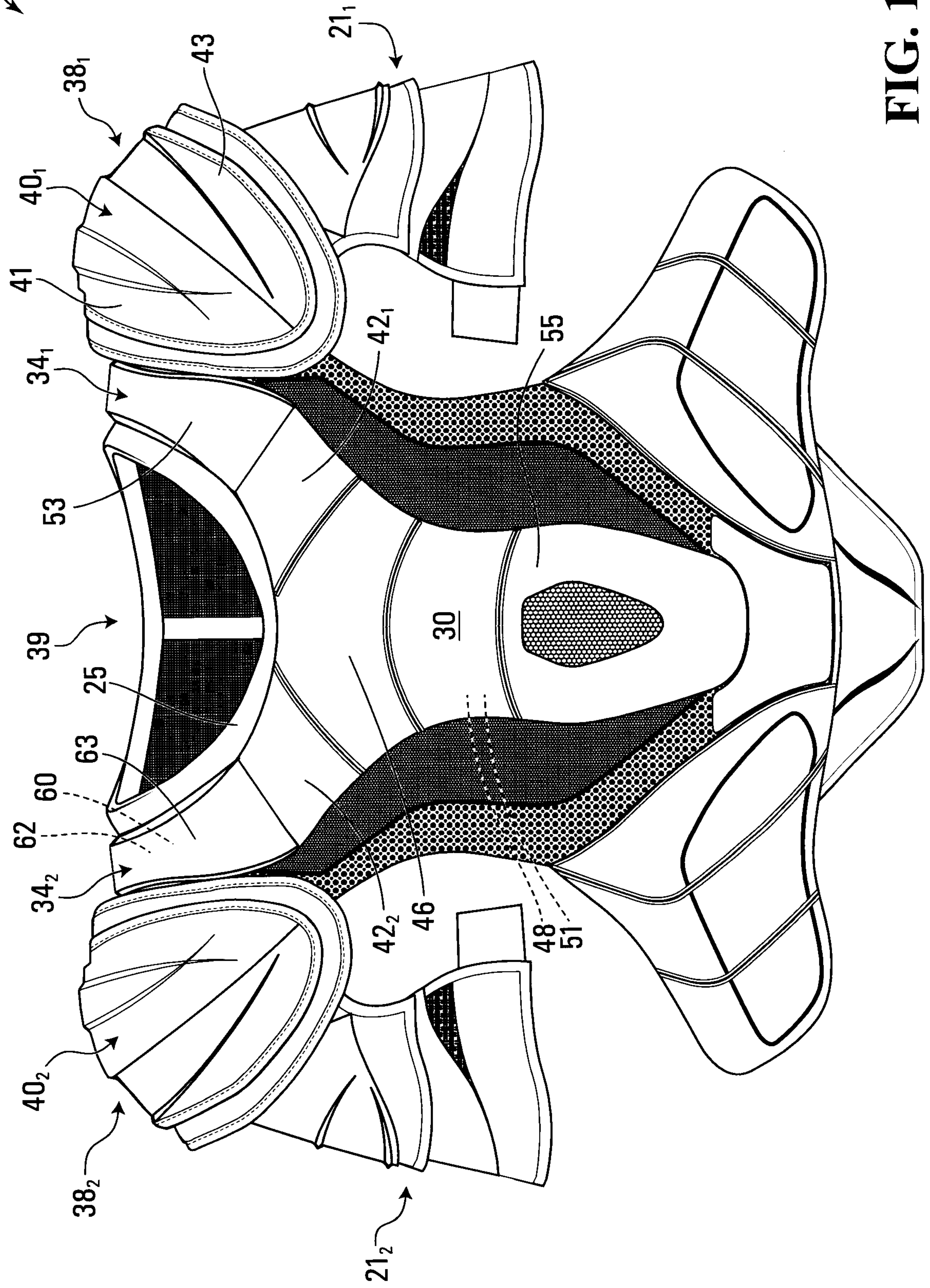

FIG. 1

+

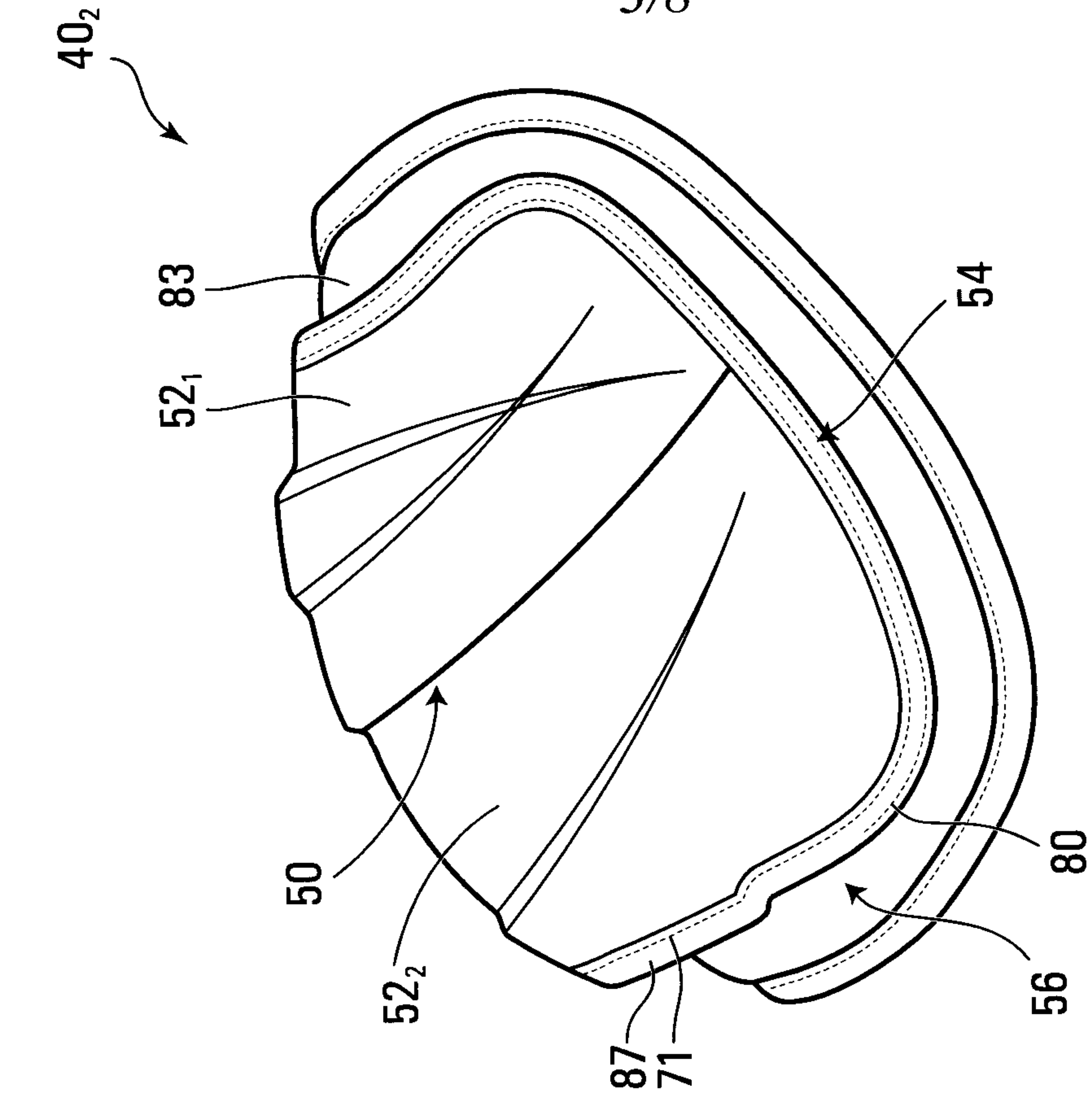

FIG. 3

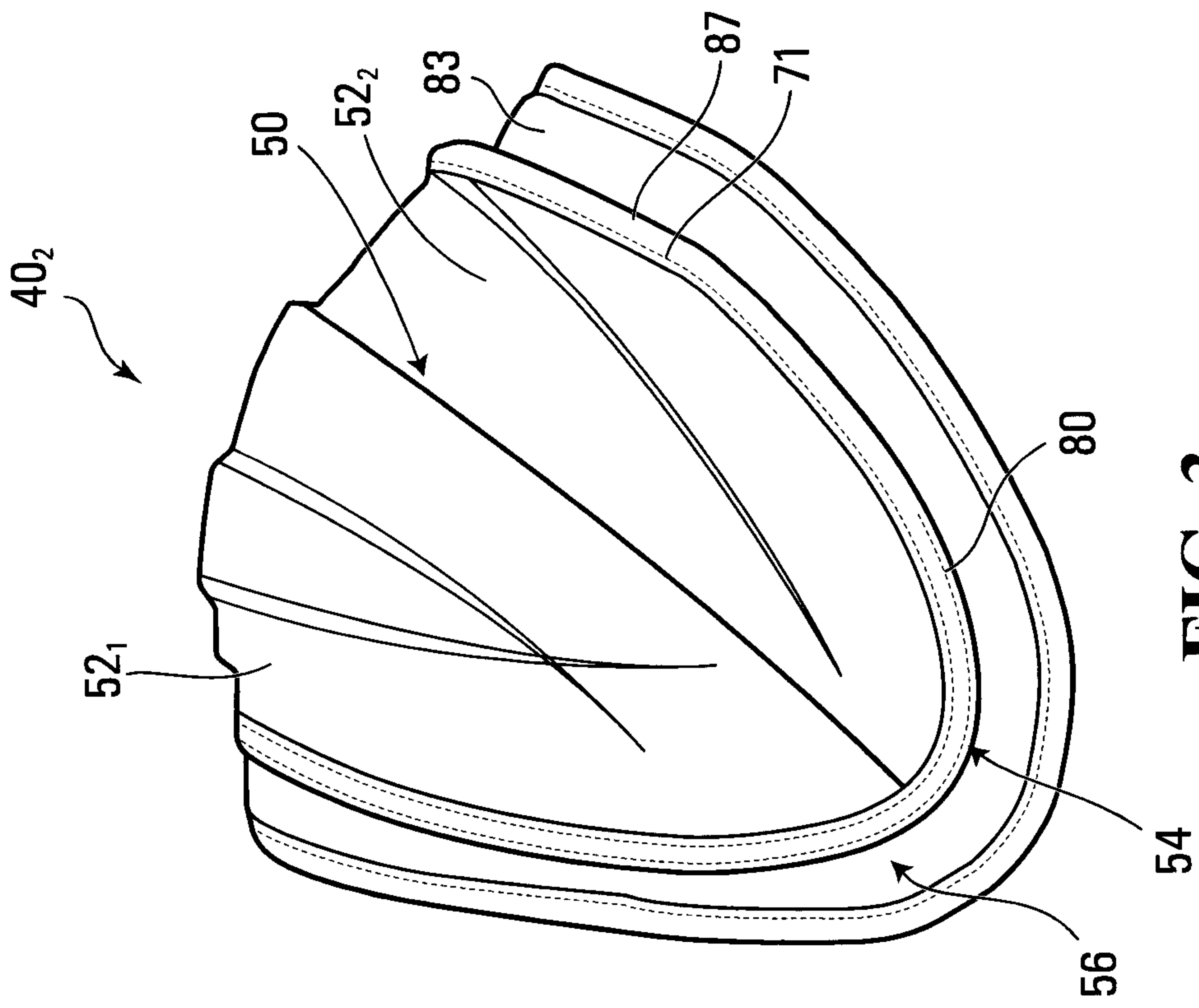

FIG. 4

+

+

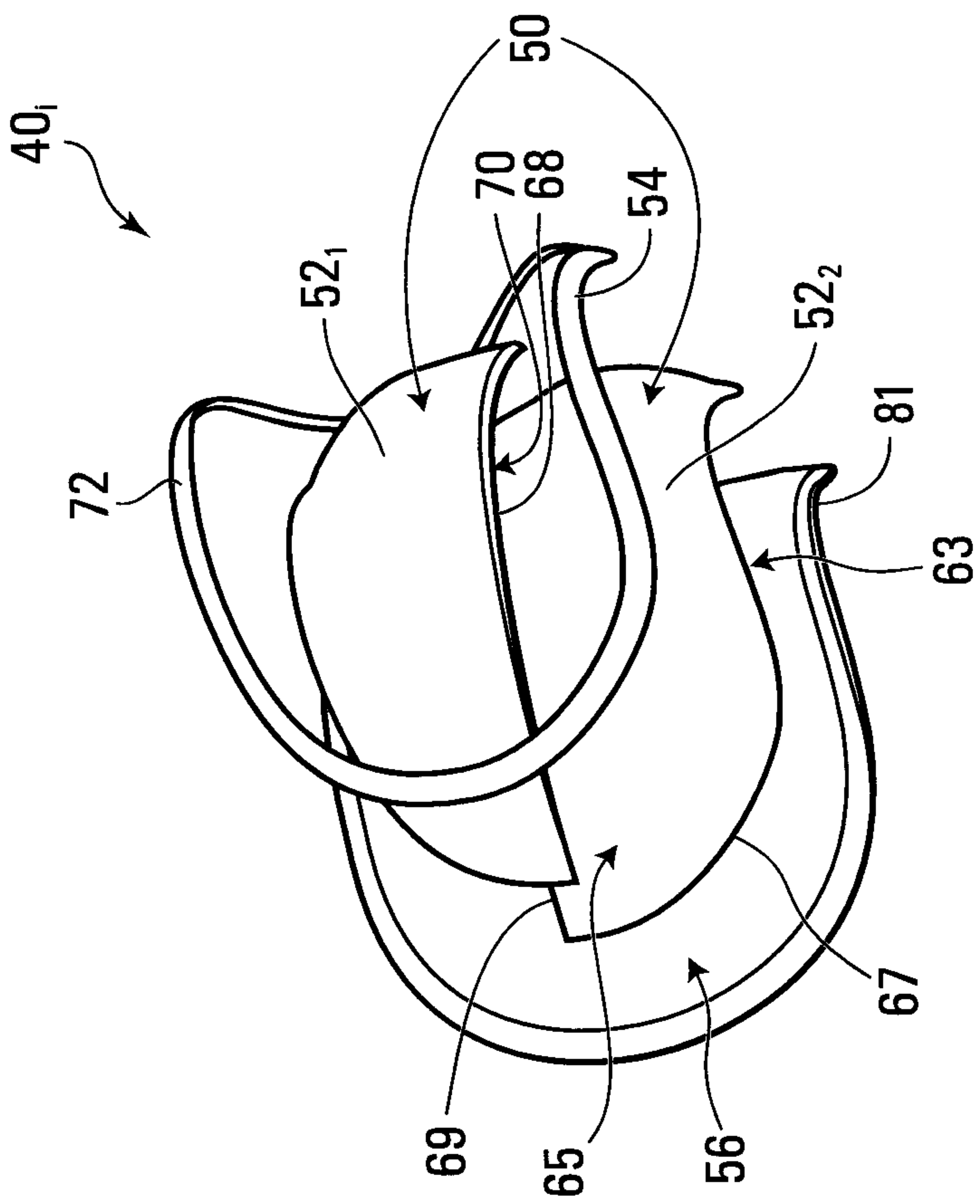

FIG. 5

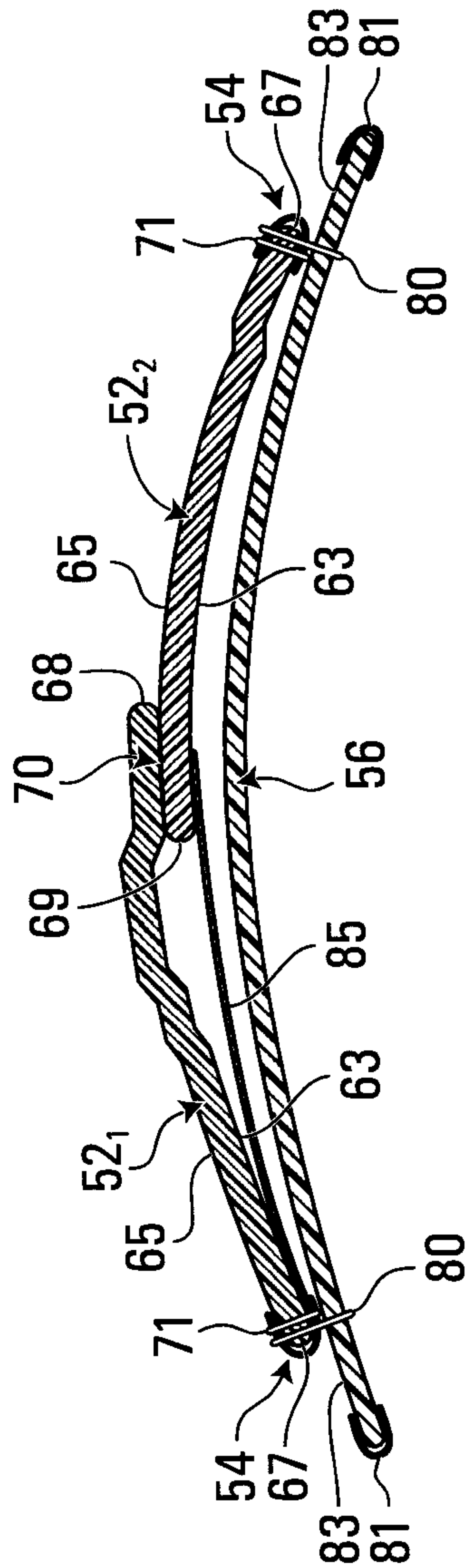

FIG. 6

+

+

+

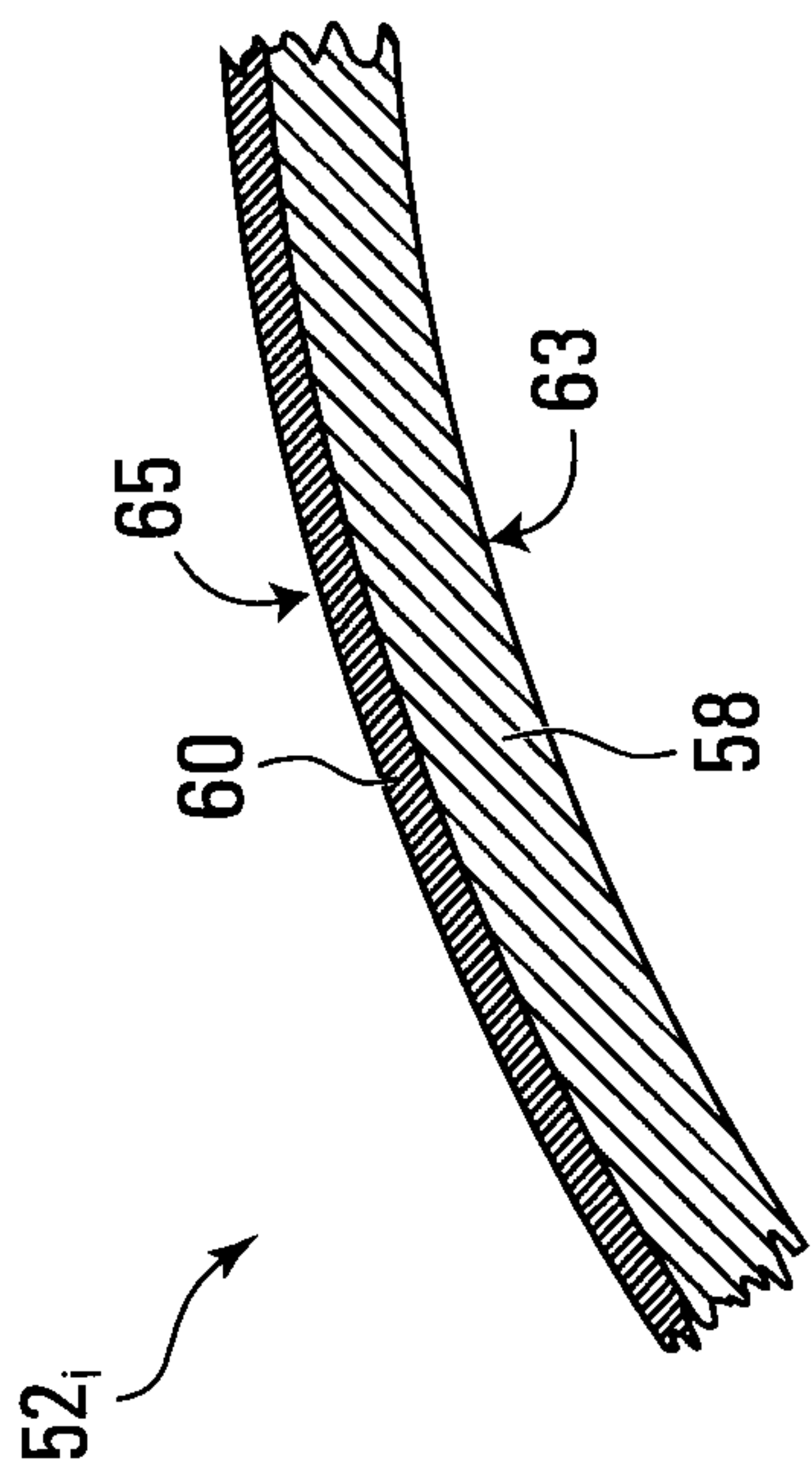

FIG. 7

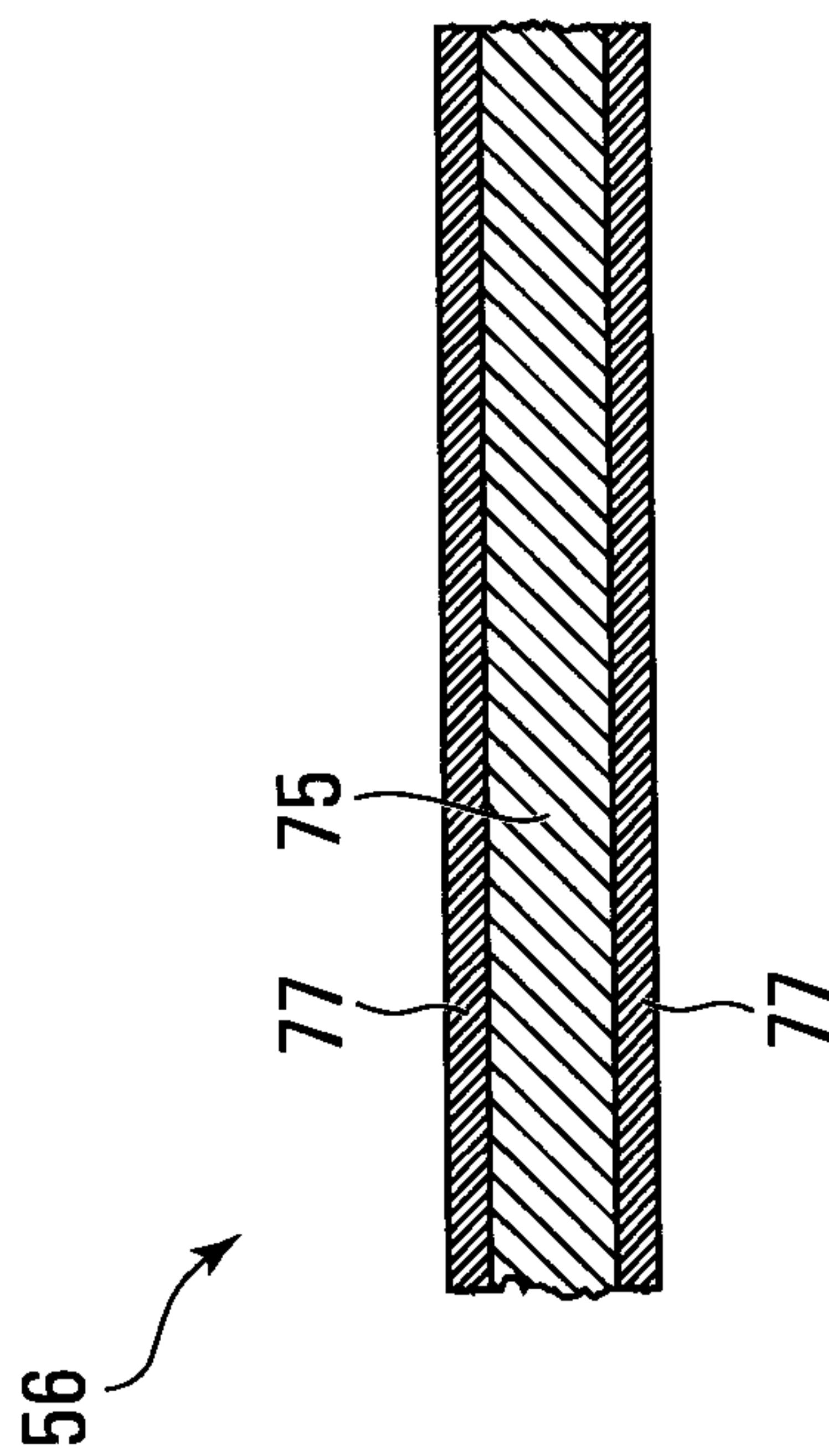

FIG. 8

+

+

6/8

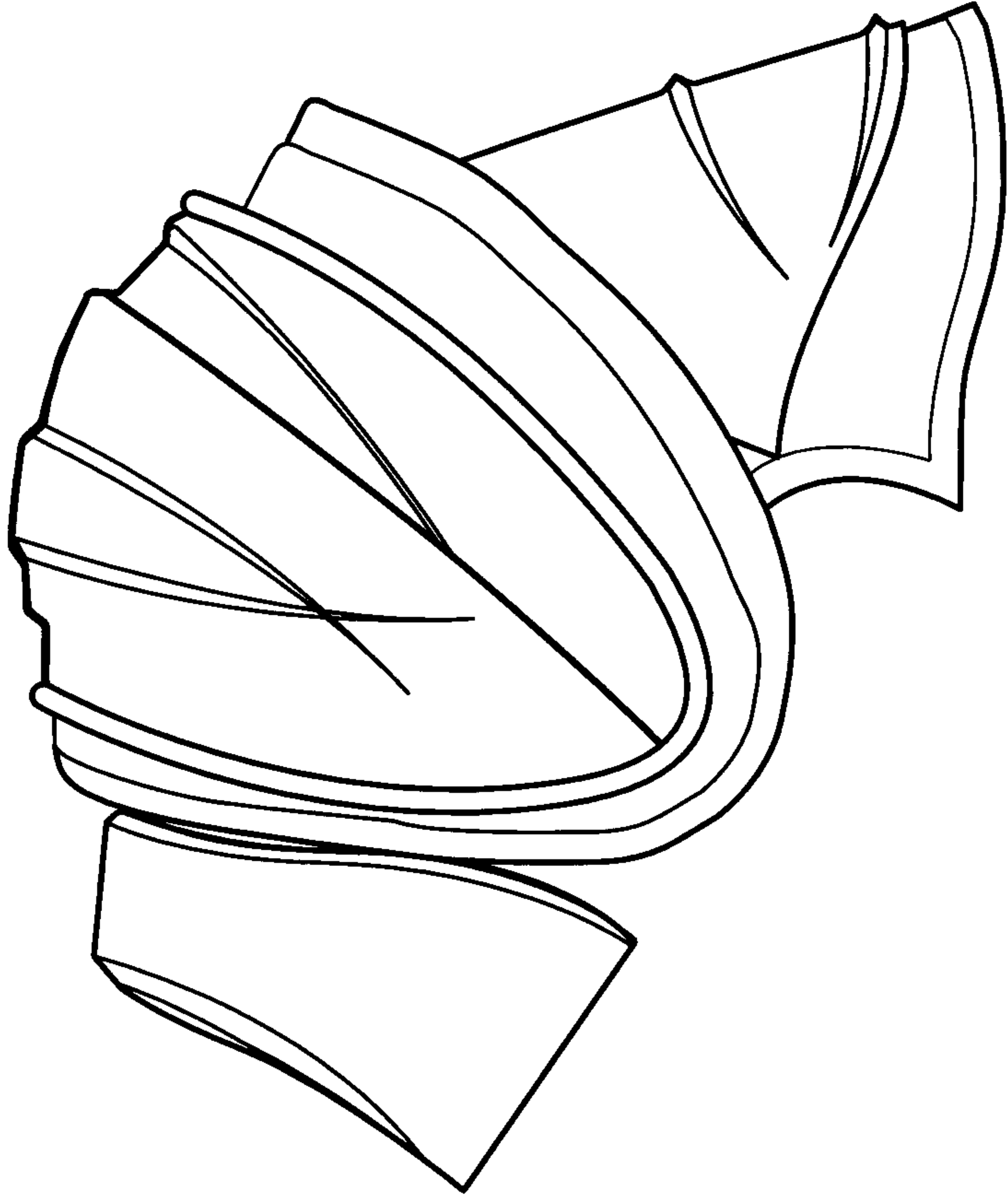

FIG. 9B

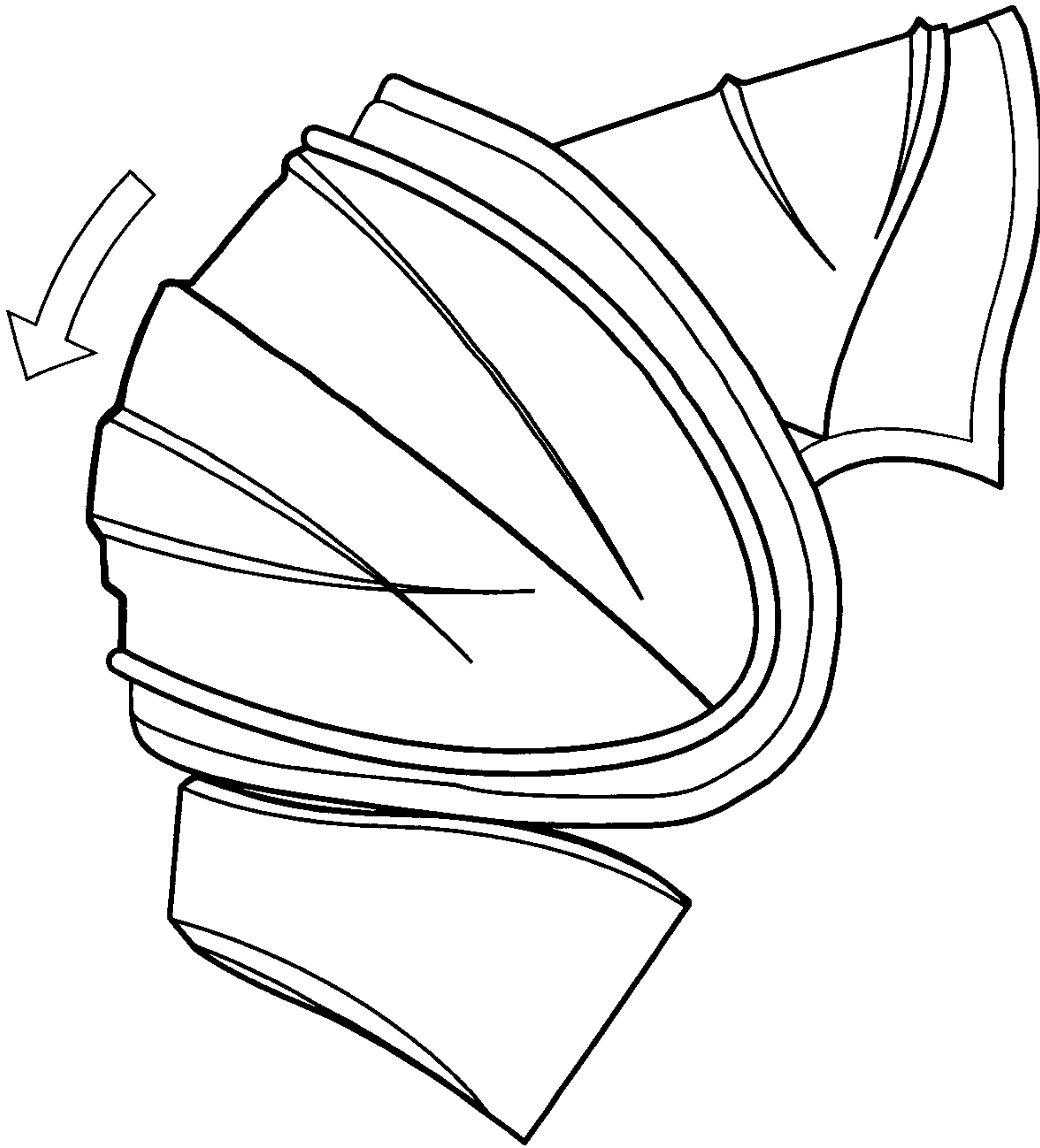

FIG. 9A

+

+

7/8

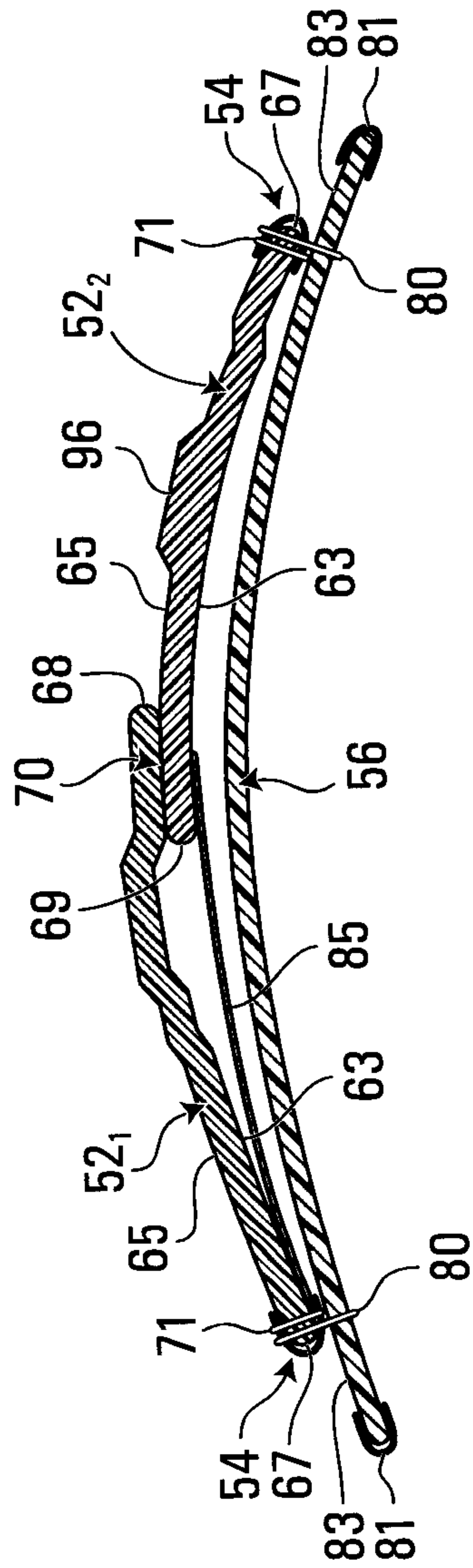

FIG. 10

+

+

8/8

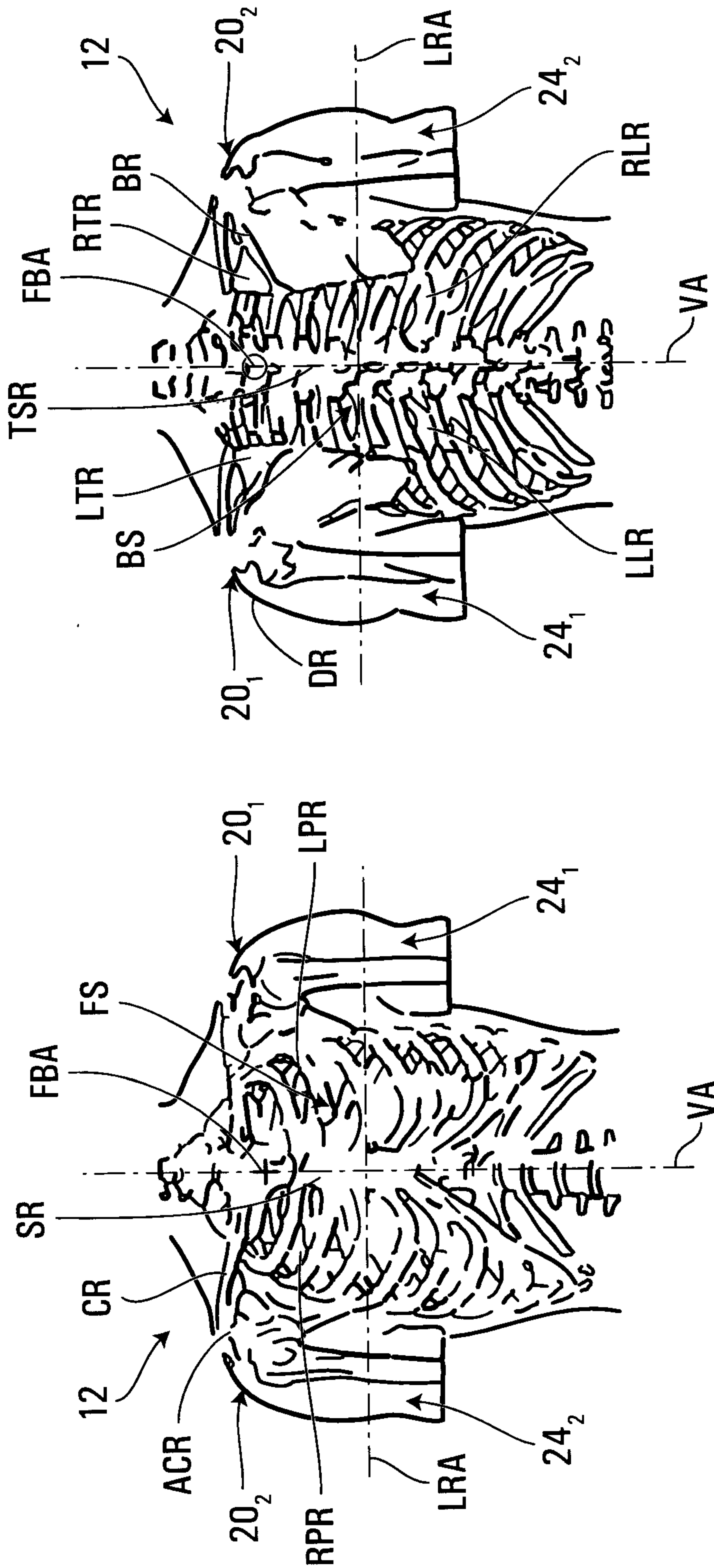

FIG. 11B

FIG. 11A

+

