

May 30, 1967

R. M. REYES

3,321,943

KEY SAFE

Filed Feb. 25, 1965

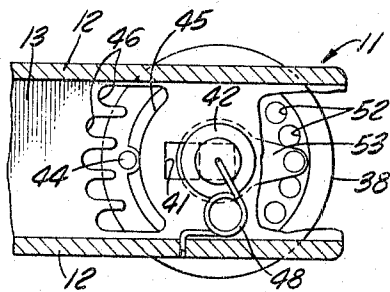
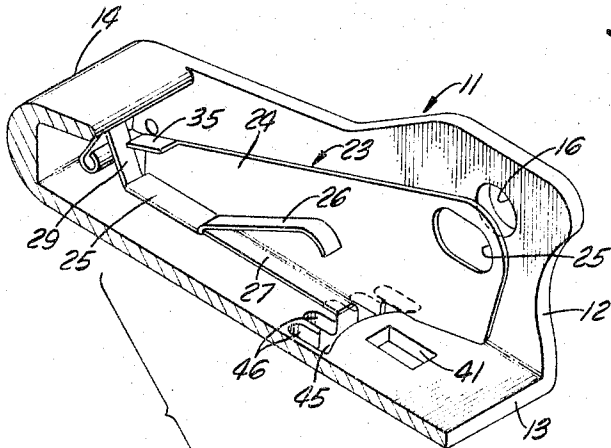
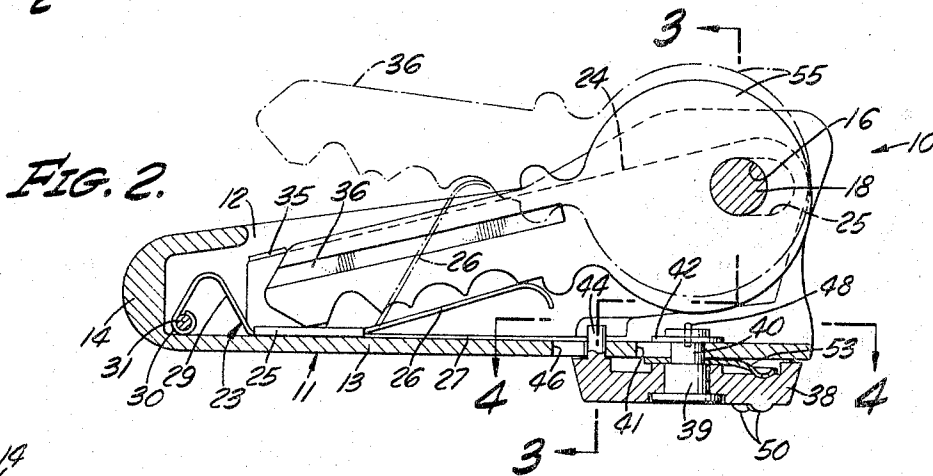
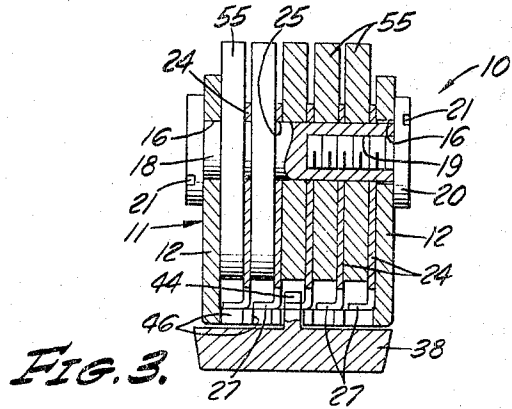
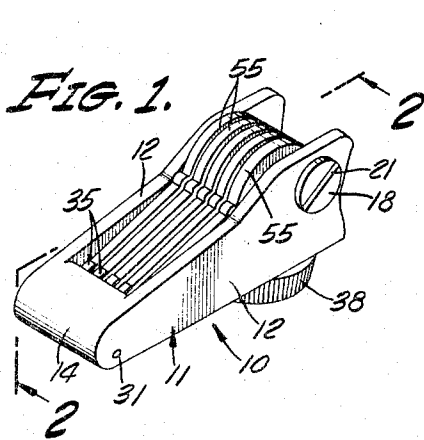

FIG. 5.

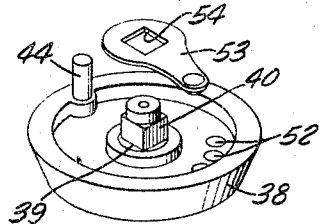

FIG. 4.

INVENTOR.
ROBERT M. REYES

BY

Robert M. Reyes
ATTORNEY

1

3,321,943
KEY SAFE

Robert M. Reyes, 614 Forest Ave.,
Los Angeles, Calif. 90033
Filed Feb. 25, 1965, Ser. No. 435,749
8 Claims. (Cl. 70-456)

This invention relates to key-retainer devices and more particularly to an improved key safe designed for enclosing a plurality of keys compactly and featuring simple foolproof means for selectively releasing any one of the keys at the user's option.

In modern-day society individuals have need for carrying a number of keys to gain access to their homes, offices, automobiles, safe deposit boxes, garages and the like. This presents a need for simple, effective retainer means for holding these several keys compactly and neatly assembled for carrying on the person or in purses, and particularly for reliable, easily-operated means for selecting a desired key without need for visual inspection of an array of keys.

To meet these objectives, designers have proposed a variety of stowage devices many of which lack important capabilities such as provision for identifying or quickly selecting a given key without visual inspection and suitable means for releasing only a desired key. Accordingly it will be understood that these various prior designs are subject to a wide variety of objections sought to be avoided by the present invention.

A further and highly important aim of this invention is to provide a simple, inexpensive and highly reliable key safe having a reduced number of components cooperating with one another to store a considerable number of keys compactly and featuring easily manipulated key selector means suitable for operation by touch and without visual assistance to the end that the user may select and extend a desired key in the dark.

Accordingly, it is a primary object of the present invention to provide an improved, simplified key safe occupying a minimum of space for storing a plurality of keys compactly in side-by-side relation.

Another object of the invention is the provision of an improved key safe having easily operated key selector means freely operated without visual aid to select a desired key with accuracy and reliability.

Another object of the invention is the provision of a key safe having a single part serving multiple functions such as the key detent, the key separator, the key ejector and as a detent actuator.

These and other more specific objects will appear upon reading the following specification and claims and upon considering in connection therewith the attached drawing to which they relate.

Referring now to the drawing in which a preferred embodiment of the invention is illustrated.

FIGURE 1 is a perspective view of one preferred embodiment of the invention showing all keys in stored position;

FIGURE 2 is a longitudinal sectional view on an enlarged scale taken along line 2-2 on FIGURE 1;

FIGURE 3 is a cross-sectional view taken along broken line 3-3 on FIGURE 2;

FIGURE 4 is a fragmentary cross-sectional view taken along line 4-4 on FIGURE 2; and

FIGURE 5 is an exploded view of certain of the principal components.

Referring to the drawing, there is shown one preferred embodiment of the invention key safe, designated generally 10, and having an elongated main body 11 of channel shape in cross-section. This main body includes identical side walls 12, 12 integral with an interconnecting web 13 and closed across the narrow forward end

2

by a rounded transverse wall 14. It will be understood that this one-piece main body may be formed of metal or molded from plastic or other suitable material. The wider or rear ends of side walls 12, 12 are provided with aligned openings 16, 16 to receive a key-retaining pivot pin 18, as is best shown in FIGURE 3. The forward end of pin 18 is provided with a threaded well 19 receiving the threaded shank of a screw 20. The heads of pin 18 and screw 20 are preferably provided with a kerf 21 to receive a thin coin or screwdriver bit when inserting the keys initially or when exchanging them later for different ones.

Referring now more particularly to FIGURE 5, there is shown one of the several unitary identical subassemblies designated generally 23 having multiple and important functions now to be described. Subunits 23 as herein shown are blanked from thin resilient sheet material as Phosphor bronze or the like. Each subunit includes an upright divider partition 24 parallel to side walls 12, 12 and serving to separate adjacent pairs of keys from one another as is best illustrated in FIGURE 3. The rear end of each partition is provided with an elongated opening 25 loosely receiving pivot pin 18 to hold these members in assembled position as well as permitting each unit 23 to move bodily for a limited distance lengthwise of the main body for purposes to be explained presently.

The inner lateral edge of partitions 23 is bent to lie at right angles to the partition generally. It is further pointed out that the flange so formed is slit for a major portion of its length, and the outer half is folded back upon itself as is clearly indicated at 25 in FIGURE 5. Portion 26 corresponding to the length of the slit is bent to the configuration indicated to provide a resilient key ejector having a width no greater than that of the thickness of the key and designed to underlie the shank end of the key in the stored position of the key (see FIGURE 2). The portion 27 underlying ejector spring 26 lies flush against the interior surface of web 13 of the main body and serves as the key detent actuator means as will be described in greater detail presently. An inverted V-shaped extension 29 of detent actuator 27 projects forwardly of partition 24 and has the important function of providing a spring return for detent 35. The free end 30 of each detent spring 29 is curled about a common retainer pin 31 having its ends supported in the forward ends of side walls 12.

The upper lateral edge of partition 24 is bent over at its forward end to provide a key detent 35 overlying the pointed forward end 36 of an associated key as the latter is being pivoted into its stored position between the side walls of the main body of the safe. When detent 35 is in its normal position shown in FIGURE 2, the underlying key is locked in its storage position. To release the key, it is necessary that subunit 23 be shifted bodily forwardly in opposition to detent spring 29 sufficiently to permit the key to be released from beneath detent 35 and pivoted upwardly as to the dot-and-dash line position indicated in FIGURE 2.

The selector means for selecting a desired key for release and for shifting detent 35 to its release position will now be described. As is best shown in FIGURE 5, the selector device comprises a rotary knob 38 journaled on the circular shank end 39 of a shouldered rivet having a square inner end 40. Square end 40 is slidingly supported in a rectangular slot 41 formed in web portion 13 of the main body, the inner end of this shank being beaded over against a washer 42 in a manner holding these parts loosely assembled in slot 41.

Knob 38 is provided near its rim with an axial extension or pin 44 which projects through and is movable along an arcuate slot 45 formed in web 13. The forward or outer edge of this slot is notched as indicated at 46

3

for loosely receiving pin 44 when it is aligned with a selected one of the notches, there being a separate notch for each key storage cell.

Selector knob 38 is normally held resiliently against the rear end of slot 41 by means of a torsion spring 48 (FIGURE 4) having one end anchored in main body 11 and the other end socketed in an opening in the end of the shouldered rivet supporting knob 38. Accordingly, normally the selector mechanism is held in the position shown in FIGURES 2 and 4 by spring 48 and is ineffective to release any key until the selector is shifted bodily toward the forward end of slot 41.

One of the important features of the described selector mechanism is the provision therein of means enabling the user to select the key by touch and without visual observation. This means may comprise an arcuate row of projections 50 arranged along the outer surface of the selector knob. There is one such projection for each key-receiving space and these may be distributed about the rim of the knob in a manner enabling user easily to identify which projection is properly positioned crosswise of the safe to release the particular key he desires. It is also pointed out that each one of the selector position indicators may comprise a light-reflecting or a luminous dot or numeral formed in the knob and easily seen under poor lighting conditions.

Another feature of the device is the provision of selector retention means for holding knob 38 in a desired position. This means is best shown in FIGURES 2, 4 and 5 and comprises a series of dimples 52 formed in the underside of the knob for seating the complementally shaped end of a resilient keeper 53 having a noncircular opening 54 having a close fit with the correspondingly shaped end 40 of pin 39. It will therefore be clear that the keeper cannot rotate and that its rounded end seats successively in dimples 52 as selector knob 38 is rotated to its several key selecting positions.

The operation of the described safe will be quite apparent from the foregoing detailed description of its components and their operating relationship to one another. The desired number of keys 55 are readily mounted about pivot pin 18 in the manner described above. However, it will be apparent that all key receiving cells need not be occupied since subunits 23 cooperate with one another in holding a lesser number of keys properly assembled within the safe. If desired, the edge portion of the key heads projecting beyond the upper edges of side walls 12 may be filed away so that in the stored position of the keys substantially no part thereof will project beyond the safe wall.

To lock the keys in stored position the operator merely rotates the keys forwardly causing the conventionally tapered forward ends of the key to engage the adjacent end edge of detent 35 thereby camming the detent along with the remainder of subunit 23 forwardly in opposition to spring means 29. Immediately the key end under-rides the detent, spring 29 shifts detent 35 rearwardly to the position shown in FIGURE 2 thereby positively latching the overlying key in stored position. At this time, ejector spring 26 is depressed as shown in FIGURE 2 and stressed in readiness to eject the key as soon as it is released from beneath its locking detent.

A given key is released by rotating selector 38 until pin 44 underlies the shank of the key to be released. This pin will then be aligned with one of notches 46 and opposite the end of one of the detent actuators 27 (see FIGURE 5). The operator then shifts selector knob 38 bodily lengthwise of slot 41 causing pin 44 to bear against the end of actuator member 27 and shift the entire subunit 23 forwardly to compress spring 29. The forward movement of unit 23 carries detent 35 with it sufficiently to allow ejector spring 26 to pivot the selected key out of the safe.

After the key has been used in the usual manner it is returned to its locked, stored position in the manner described above.

4

While the particular key safe herein shown and disclosed in detail is fully capable of attaining the objects and providing the advantages hereinbefore stated, it is to be understood that it is merely illustrative of the presently preferred embodiment of the invention and that no limitations are intended to the details of construction or design herein shown other than as defined in the appended claims.

I claim:

1. A key safe comprising an elongated rigid main body having first and second ends and a key-retaining pin supported crosswise of said first end by the side walls of said main body for pivotally supporting a plurality of keys thereon in side-by-side parallel relation, separate spring-pressed detent means positioned to engage and hold the forward end of each individual key at the second end of said main body, rotary key selector means confined to one side of said main body and supported at said first end on an axis extending crosswise of said main body and movable bodily relative thereto after being rotated into any particular key selector position, means normally resiliently holding said selector means in a retracted position, and means actuable by bodily radial movement of said rotary key selector means in a predetermined direction in opposition to said resilient means normally holding the same retracted to release a selected key from said detent means for rotary movement of said selected key outwardly from said main body and about the axis of said key-retaining pin.

2. A key safe as defined in claim 1 characterized in the provision of a thin separator partition between each adjacent pair of keys, ejector spring means mounted on said partitions in a position underlying the inner lateral edge of an associated key when the latter is locked in retained position beneath its own detent means whereby said ejector is effective to urge the associated key to pivot out of its stored position immediately that the key is released from its retaining detent means.

3. A key safe as defined in claim 2 characterized in that said detent means, said ejector spring and said means actuable by bodily radial movement of said key selector means are all movable bodily lengthwise of the associated key.

4. A key safe as defined in claim 1 characterized in the provision on said rotary key selector means of cooperating resilient detent means for holding said selector means in any of a plurality of positions each associated with a different one of said keys.

5. A key safe having an elongated channel-shaped main body comprising side walls which taper from a maximum width at a first end to a narrow width at a second end having a rounded transverse closure wall, a pivot pin between the said side walls at said first end for pivotally supporting the head ends of a plurality of keys, separate key detent, detent actuator, and key ejector means for each key supported lengthwise of and within the second end of said main body, and unitary key selector means movably mounted on said main body and bodily reciprocable lengthwise thereof after being rotated to a position corresponding to a selected key to actuate said detent actuator thereby to disengage the same from the selected key and permitting said ejector spring to rotate the selected key about said pivot pin and out of a substantially concealed position between the side walls of said main body.

6. A key safe as defined in claim 5 wherein said pivot pin is removable to facilitate exchange of keys, and wherein said detent, said detent actuator and said key ejector means for all keys include common means for holding the same assembled within the narrow end of said main body.

7. A key safe as defined in claim 6 characterized in that individual ones of said detent, detent actuator and ejector spring means for a given key are formed in one unitary subunit from resilient sheet material.

5

8. A key safe as defined in claim 7 characterized in that said unitary subunits for each key include a thin separator partition lying parallel to the side walls of said main body and serving to separate one key receiving space from an adjacent key-receiving space.

6

2,560,595	7/1951	Poncar	-----	70-456
2,618,958	11/1952	Goodson	-----	70-456
2,695,511	11/1954	Wing et al.	-----	70-456
2,851,872	9/1958	Stow	-----	70-456

5

References Cited

UNITED STATES PATENTS

1,573,723	2/1926	Long	-----	70-456
2,451,056	10/1948	Berger et al.	-----	70-456 10

MARVIN A. CHAMPION, *Primary Examiner.*

P. TEITELBAUM, *Assistant Examiner.*