



**Description****BACKGROUND OF THE INVENTION**

## 1. Field of the Invention

**[0001]** The present invention relates to suction tools for electric cleaners and electric cleaners using the suction tool.

## 2. Background Art

**[0002]** A conventional suction tool for electric cleaner rotates a rotary brush typically by an electric motor to suck in dust through a suction port facing a surface to be cleaned. This type of suction tool for electric cleaner needs a space at an end portion of the suction tool for accommodating such an element as a belt, a pulley or the like which transmits power to the rotary brush. Therefore, the suction port cannot be provided over the full length in a longitudinal direction of the bottom surface of the suction tool for electric cleaner. The end portion of the suction tool thus becomes a suction dead space where the suction port cannot be extended. Thus, the end portion of the suction tool cannot suck in and remove dust on the surface to be cleaned.

**[0003]** To remove dust on the surface to be cleaned below the suction dead space of the suction tool, a suction tool having a structure in which brushes are provided at and fixed to both end portions of the bottom surface (facing the surface to be cleaned) of the suction tool is disclosed in PTL 1 (Japanese Patent Unexamined Publication No. 2011-36445).

**[0004]** However, such conventional types of suction tool for electric cleaner as those described above have a structure for collecting dust below the end portions of the suction tool directly by the fixed brushes and the like, but they do not have a structure which would enable to suck in dust below the end portions of the suction tool by the sucking power of the electric cleaner. In this type of conventional suction tool for electric cleaner, the dust remains on the fixed brushes, and thus it is necessary to remove the dust from the fixed brushes by hands or a brush, which is troublesome. Further, dust near the end portions of the suction tool remains as it is without being collected because the fixed brushes cannot directly reach the dust. Thus, the cleaning efficiency of the conventional types of suction tool for electric cleaner is poor. Still further, the conventional types of suction tool for electric cleaner require additional elements such as the fixed brushes, which causes the increase in the number of components of suction tool as well as manufacturing costs and makes the structure of suction tool complicated.

**[0005]** Furthermore, with respect to a suction tool having a rotary cleaning body driven by the electric motor as disclosed in PTL 1, a space for accommodating a pulley or the like which transmits power to the rotary brush is

needed at an end portion of the rotary cleaning body. In PTL 1, no modification is applied to the structure in connection with this space. In PTL1, this space is kept and secured without any alteration being applied to the structure of the suction tool. As described above, PTL 1 only discloses the fixed brushes which are disposed in the suction dead space of the suction tool where the suction port cannot be provided.

10 **SUMMARY OF THE INVENTION**

**[0006]** The present invention is provided to solve the aforementioned disadvantages of the conventional technologies. In a suction tool for electric cleaner of the present invention, having a rotary brush rotated by a power source, such as an electric motor, a suction port can be extended to an end portion of the bottom surface of the suction tool. Specifically, the present invention provides a suction tool for electric cleaner that can suck in and remove dust even at the end portions of the bottom surface, facing a surface to be cleaned, of the suction tool.

**[0007]** More specifically, to solve the disadvantages of the prior art technologies, the suction tool for electric cleaner of the present invention includes a suction tool body having a suction port which has an opening facing the surface to be cleaned, a rotary brush rotatably provided in the suction tool body for scraping out the dust on the surface to be cleaned, an electric motor provided inside the suction tool body for driving the rotary brush, and a belt for transmitting a driving force of the electric motor to the rotary brush. The suction tool for electric cleaner of the present invention further includes a brush cover detachably provided on the bottom side of the suction tool body, an outer wall member provided on the brush cover and surrounding the suction port, and a lid provided on at least one end portion in the longitudinal direction of the brush cover for protecting the belt from external contact. On a surface of the lid facing the surface to be cleaned, a groove is formed by vertical surfaces (surfaces perpendicular to the surface to be cleaned) of the outer wall member and arc surfaces which are formed on the lid. The groove formed on the lid provides a channel space where the air flows through the end portion in the longitudinal direction of the bottom side of the suction tool body and through the surface to be cleaned.

**[0008]** The structures of the present invention as described above enable to extend the suction port to an end portion in the longitudinal direction of the bottom side of the suction tool body, where a suction port is not successfully provided by the conventional technologies.

**BRIEF DESCRIPTION OF THE DRAWINGS**

55 **[0009]**

Fig. 1 is a front view of an appearance of an electric cleaner having a suction tool for electric cleaner in

accordance with a preferred embodiment of the present invention.

Fig. 2 is a plan view illustrating the suction tool for electric cleaner with a brush cover having being removed from the suction tool for electric cleaner in accordance with the preferred embodiment of the present invention.

Fig. 3 is a plan view illustrating the suction tool for electric cleaner with the brush cover being attached to the suction tool for electric cleaner in accordance with the preferred embodiment of the present invention.

Fig. 4 is a plan view of the brush cover of the suction tool for electric cleaner seen from the bottom side in accordance with the preferred embodiment of the present invention.

Fig. 5 is a magnified view of Part A in Fig. 3, illustrating a shape of a groove in a lid of the brush cover of the suction tool for electric cleaner in accordance with the preferred embodiment of the present invention.

Fig. 6 is a sectional view taken along Line 6-6 in Fig. 3, illustrating a cross-sectional shape of the lid of the brush cover of the suction tool for electric cleaner in accordance with the preferred embodiment.

Fig. 7 is a sectional view taken along Line 7-7 in Fig. 3, illustrating a cross-sectional view of the shape of the lid provided in the suction tool for electric cleaner in accordance with the preferred embodiment of the present invention.

## DETAILED DESCRIPTION OF PREFERRED EMBODIMENTS

**[0010]** A preferred embodiment of the present invention is described below with reference to drawings. It is apparent that the scope of the present invention is not limited in any way by the preferred embodiment herein.

(PREFERRED EMBODIMENT)

**[0011]** Fig. 1 is a front view of an appearance of electric cleaner 100 having a suction tool 1 for electric cleaner 100 in the preferred embodiment of the present invention.

**[0012]** As shown in Fig. 1, cleaner body 3 includes a built-in electric blower for generating a suction airflow, dust chamber 2, and suction tool 1 for electric cleaner 100 (hereafter referred to as suction tool body 1).

**[0013]** Fig. 2 is a plan view illustrating a state that brush cover 17 is detached from suction tool body 1. Fig. 3 is a plan view illustrating a state that brush cover 17 is attached to suction tool body 1. Fig. 4 is a plan view of brush cover 17 seen from the bottom side (the side facing the surface to be cleaned) of suction tool body 1. Fig. 5 is a magnified view of Part A in Fig. 3, illustrating a shape of groove 19 formed on lid 16 of brush cover 17.

**[0014]** As shown in Figs. 2 and 3, suction tool body 1 includes suction port 10 for sucking in dust, rotary brush

11 with brush 11a for scraping out dust, an electric motor for driving rotary brush 11, and belt 12 for transmitting a driving force from the electric motor to rotary brush 11.

**[0015]** Brush cover 17 is detachably provided on the bottom side of suction tool body 1 so that rotary brush 11 can be removed for maintenance, such as for removing the dust that is wound around rotary brush 11.

**[0016]** When brush cover 17 shown in Fig. 2 is attached to suction tool body 1 in such a way that brush cover 17 covers rotary brush 11 which is exposed to the bottom side (the side facing the surface to be cleaned) of suction tool body 1, the state that brush cover 17 is attached to suction tool body 1 as shown in Fig. 3 is obtained.

**[0017]** Also shown in Fig. 3, outer wall member 18 is provided on brush cover 17 and is provided to surround suction port 10 of suction tool body 1. Each of the surfaces of outer wall member 18, which faces the surface to be cleaned, has a flat surface and is provided at substantially the same height in a direction vertical to the bottom side of suction tool body 1. More specifically, as shown in Fig. 5, front outer wall 18a of brush cover 17, rear outer wall 18c of suction tool body 1, and side outer walls 18b on the left and right sides of brush cover 17 are connected to each other at substantially the same height in a direction vertical to the bottom side of suction tool body 1. Brush cover 17 has an opening inside outer wall member 18 surrounded by front outer wall 18a, rear outer wall 18c, and side outer walls 18b. This opening corresponds to an opening of suction port 10 of suction tool body 1.

**[0018]** As shown in Figs. 2 and 3, lid 16 for protecting belt 12 from being contacted by an external contact is provided at an end portion in the longitudinal direction of brush cover 17.

**[0019]** As shown in Fig. 4, wall 15 is provided in inside of lid 16 and is provided on the back side of the surface of lid 16 facing the surface to be cleaned. Also, wall 15 is provided to divide a space in the inside of lid 16 to accommodate rotary brush 11 and belt 12 in the divided spaces respectively.

**[0020]** As shown in Fig. 3, front rollers 20 are provided at a front end of brush cover 17, and rear rollers 21 are provided at a rear end on the bottom side of suction tool body 1. Suction tool body 1 in the preferred embodiment is configured to provide as minimum gap as possible between the bottom side of suction tool body 1 and the surface to be cleaned when suction tool body 1 is placed on the surface to be cleaned, and when front rollers 20 and rear rollers 21 come to contact with the surface to be cleaned. In other words, the gap between the flat surface of outer wall member 18 and the surface to be cleaned is set to have a predetermined clearance. In this case, outer wall member 18 faces the surface to be cleaned and is constituted by the flat surfaces of front outer wall 18a, rear outer wall 18c and side outer wall 18b. This predetermined clearance is set, for example, in a range of from 0.5 mm to 1.5 mm to prevent the surface to be cleaned from being damaged when the bottom side of suction tool body 1 is placed on the surface to be

cleaned and comes to contact with the same.

**[0021]** Next is described groove 19 formed by lid 16 and outer wall member 18 with reference to Figs. 5, 6 and 7.

**[0022]** Fig. 6 is a sectional view of lid 16 taken along Line 6-6 in Fig. 3, showing a cross-sectional shape of lid 16. Fig. 7 is a sectional view of lid 16 taken along Line 7-7 in Fig. 3, showing another cross-sectional shape of lid 16.

**[0023]** As shown in Figs. 5, 6, and 7, groove 19 is formed by lid 16 and outer wall member 18. More specifically, groove 19 is formed by groove 19a and groove 19c shown in the sectional view in Fig. 6, and groove 19b shown in the sectional view in Fig. 7. Groove 19a, groove 19c and groove 19b are connected to each other and form a substantially U-shape. A depth of groove 19, i.e., a position of groove 19 in the height direction (a direction perpendicular to the surface to be cleaned), is preferably set, although it depends on the shape of belt 12, for an upper end of groove 19 (an end furthest from the flat surface of outer wall member 18) to be located at a height in a range of from 3 mm to 8 mm in the direction away from the flat surface of outer wall member 18 facing the surface to be cleaned.

**[0024]** Groove 19 formed on lid 16 is now described below in more details.

**[0025]** As shown in the sectional view in Fig. 6, the shape of lid 16 is designed so as to correspond to the shape of belt 12. More specifically, in the preferred embodiment, lid 16 is designed to have an arc shape which corresponds to the arc shape of belt 12.

**[0026]** A clearance is provided between belt 12 and lid 16 to an extent not to at least obstruct the rotation of belt 12. Preferably, the clearance is set to have as a minimum clearance as feasible so that lid 16 does not obstruct the rotation of belt 12.

**[0027]** With this structure, as shown in Fig. 6, groove 19a and groove 19c are formed by arc-shaped surface 16a and arc-shaped surface 16c of lid 16 and vertical surface 18d (a surface perpendicular to the surface to be cleaned) of outer wall member 18. The shape of lid 16 is not limited to be an arc shape but can be other shapes as long as the clearance for preventing lid 16 from obstructing the rotation of belt 12 is secured. It is preferable that the shape of lid 16 is designed to provide the clearance by way of forming the grooves on lid 16, in which the grooves include groove 19a and groove 19c and are formed by vertical surface 18d of outer wall member 18 and the surface of lid 16 facing the surface to be cleaned. By designing the shape of lid 16 to have a shape corresponding to the shape of belt 12 to minimize the clearance between lid 16 and belt 12, the surface of lid 16 facing the surface to be cleaned can be positioned up in a direction away from the surface to be cleaned, or away from the flat surface of outer wall member 18 facing the surface to be cleaned. The further the surface of lid 16 facing the surface to be cleaned is positioned away from the surface to be cleaned, or away from the flat surface

of outer wall member 18 facing the surface to be cleaned, the larger groove 19a and groove 19c can be formed. It should be noted that, as described above, the clearance between belt 12 and lid 16 is secured to prevent lid 16 from obstructing the rotation of belt 12.

**[0028]** As shown in the sectional view in Fig. 7, lid 16 has tilted surface 16b which is tilted in a direction away from the surface of lid 16 facing the surface to be cleaned (in a direction close to belt 12). Groove 19b is formed by tilted surface 16b of lid 16 and a vertical surface (a surface perpendicular to the surface to be cleaned) of side outer wall 18b. By the above-described structures, larger groove 19 can be formed.

**[0029]** The operations and effects of suction tool body 1 for electric cleaner 100 in the preferred embodiment as configured above are now described below.

**[0030]** When the operation of electric cleaner 100 starts in a state that suction tool body 1 is placed on the surface to be cleaned, rotary brush 11 is driven by the electric motor inside suction tool body 1. The dust scraped up by rotary brush 11 is then sucked in and collected in dust chamber 2 by the sucking power of the electric blower.

**[0031]** At this point, a suction airflow in suction tool body 1 reaches suction port 10 through the predetermined clearance between outer wall member 18 disposed on the bottom side (the side facing the surface to be cleaned) of suction tool body 1 and the surface to be cleaned.

**[0032]** The suction airflow reaching suction port 10 passes through groove 19 formed on lid 16, and reaches rotary brush 11. Therefore, the suction airflow passing groove 19 functions as carrying the dust on the surface to be cleaned residing below lid 16 toward rotary brush 11. Accordingly, the dust located around the end portion in the longitudinal direction of suction tool body 1, such as a portion where lid 16 is provided in the preferred embodiment, and where it is conventionally difficult to remove the dust, can be removed. Lid 16 can thus function as suction port 10.

**[0033]** More specifically, groove 19 formed up with groove 19a, groove 19b, and groove 19c, in which groove 19a, groove 19b, and groove 19c are connected each other to form a substantially U-shape, is provided on the surface of lid 16 facing the surface to be cleaned. This forms a channel space where the air passes between lid 16 and the surface to be cleaned. Since the suction airflow passes this channel space, dust on the surface to be cleaned below lid 16 can be delivered toward rotary brush 11. The larger groove 19a, groove 19b and groove 19c are formed, the stronger the sucking power will be because a larger amount of suction airflow passes through groove 19 which is formed by groove 19a, groove 19b and groove 19c. Accordingly, dust on the surface to be cleaned below the end portion in the longitudinal direction of suction tool body 1 can be sucked in and removed.

**[0034]** Still more, in the preferred embodiment, the

depth of groove 19 is preferably set at a position in a range of from 3 mm to 8mm away from the surface of outer wall member 18 facing the surface to be cleaned in the height direction (a direction perpendicular to the surface to be cleaned). This structure enables a sufficient suction airflow to flow below lid 16 for carrying dust on the surface to be cleaned below lid 16 toward rotary brush 11 and collecting dust through suction port 10. Accordingly, dust on the surface to be cleaned below lid 16 can be effectively cleaned.

**[0035]** As shown in the sectional view in Fig. 6, lid 16 has a shape corresponding to the shape of belt 12. For example, if belt 12 has an arc shape, lid 16 is formed to have an arc shape along with the arc shape of belt 12. If belt 12 has an oval shape, lid 16 is formed to have an oval shape along with the oval shape of belt 12. Arc-shaped surface 16a and arc-shaped surface 16c are provided on lid 16 to secure a clearance between belt 12 and lid 16 to prevent lid 16 from at least obstructing the rotation of belt 12. Preferably, the clearance is provided to have a space as minimum as required for preventing lid 16 from obstructing the rotation of belt 12. This structure enables to form a large space in groove 19a and groove 19c without interference between the inner surface of lid 16 and belt 12. In addition, this structure enables to increase the amount of the suction airflow flowing through groove 19a and groove 19c.

**[0036]** The shape of groove 19 is not limited to the substantially U-shape which, in the preferred embodiment, is formed by connecting groove 19a, groove 19c and groove 19b with each other. Groove 19 can be designed to have other shapes as long as the channel space for flowing the air is formed between lid 16 and the surface to be cleaned, a groove which provides a sufficient space for allowing the suction airflow to flow through this channel space is formed, and there is no interference to the operation of belt 12.

**[0037]** As described above, suction tool body 1 for electric cleaner 100 includes suction tool body 1 with suction port 10 having an opening facing the surface to be cleaned, rotary brush 11 rotatably provided on suction tool body 1 for scraping out dust on the surface to be cleaned, an electric motor provided inside suction tool body 1 for driving the rotary brush 11, belt 12 transmitting a driving force of the electric motor to rotary brush 11, and brush cover 17 detachably provided on the bottom side of suction tool body 1. Suction tool body 1 for electric cleaner 100 in the preferred embodiment further includes outer wall member 18 provided on brush cover 17 for surrounding suction port 10, lid 16 provided around the end portion of brush cover 17 for protecting belt 12 from outer contact, and groove 19 formed on lid 16. Groove 19 forms a channel space where the air flows through suction tool body 1 and the surface to be cleaned, and the suction airflow flows this channel space.

**[0038]** With these structures, suction port 10 can be extended to end portions in the longer direction on the bottom side of suction tool body 1, where it is conven-

tionally difficult to provide a suction port. Accordingly, dust on the surface to be cleaned below the end portions in the longitudinal direction of suction tool body 1 can be removed.

**[0039]** Further, the structures according to the preferred embodiment do not need additional elements, such as a fixed brush used in a conventional suction tool, suction tool body 1 for electric cleaner 100 can be produced at a low manufacturing cost, and also the cleaning efficiency of suction tool body 1 for electric cleaner 100 can be improved with a simple structure.

**[0040]** Still further, in suction tool body 1 for electric cleaner 100 in the preferred embodiment, lid 16 preferably has a shape which corresponds to the shape of belt 12, such as an arc shape. Lid 16 and belt 12 are provided in suction tool body 1 in such a way that a clearance between lid 16 and belt 12 for preventing lid 16 from obstructing the rotation of belt 12 is secured. Preferably, the clearance has a minimum but sufficient space for preventing lid 16 from obstructing the rotation of belt 12. According to the preferred embodiment of the present invention, groove 19 is formed up with lid 16 and outer wall member 18.

**[0041]** The above-described structures enable to form a large size of groove 19 without obstructing the rotation of belt 12 and to increase the amount of the suction airflow flowing through groove 19. Thus, dust on the surface to be cleaned below the end portion of suction tool body 1 can be sucked in. Accordingly, suction tool body 1 for electric cleaner 100 with high cleaning efficiency can be achieved.

**[0042]** Furthermore, the preferred embodiment of the present invention enables to suck in and remove dust on the surface to be cleaned below the end portions in the longitudinal direction of suction tool body 1 without providing a fixed brush at the end portion of suction tool body 1, while securing a space for accommodating a belt or a pulley or the like.

**[0043]** Yet further, electric cleaner 100 having high dust-collecting capacity that can collect dust on the surface to be cleaned at a corner against a wall can also be achieved by connecting suction tool body 1 for electric cleaner 100 in the preferred embodiment with cleaner body 3 which has a built-in electric blower for generating suction airflow.

**[0044]** Still more, the preferred embodiment of the present invention can achieve electric cleaner 100 that can remove dust on the surface to be cleaned below the end portions in the longitudinal direction of suction tool body 1 without providing a fixed brush, while securing a space for accommodating a belt or a pulley or the like. Furthermore, the above-described structures of the preferred embodiment of the present invention can provide electric cleaner 100 at a low manufacturing cost and can improve the cleaning efficiency of suction tool body 1 with a simple structure without providing an additional element such as a fixed brush used in a conventional suction tool.

**[0045]** As described above, the present invention offers suction tool for electric cleaner and an electric cleaner using the suction tool that have a significant effect of sucking in and removing dust on the surface to be cleaned especially at the end portions of the suction tool body. Accordingly, the present invention is broadly applicable to home-use and industrial-use electric cleaners.

5

## Claims

10

### 1. A suction tool for electric cleaner, comprising:

a suction tool body with a suction port having an opening facing a surface to be cleaned; 15  
 a rotary brush rotatably provided on the suction tool body for scraping out dust on the surface to be cleaned;  
 an electric motor provided inside the suction tool body for driving the rotary brush; 20  
 a belt for transmitting a driving force of the electric motor to the rotary brush;  
 a brush cover detachably provided on a bottom side of the suction tool body;  
 an outer wall member which is provided on the brush cover and surrounds the suction port; and 25  
 a lid provided on an end portion of the brush cover for protecting the belt,  
 wherein  
 a groove is formed on the lid, 30  
 a channel space is formed by the groove for allowing the air to flow through the suction tool body and the surface to be cleaned,  
 a suction airflow passes the channel space, and 35  
 the suction port is extended to an end portion in a longitudinal direction of the bottom side of the suction tool body.

### 2. The suction tool for electric cleaner of claim 1, wherein 40 the groove is formed by:

forming the lid to have a shape which corresponds to a shape of the belt, and 45  
 disposing the lid and the belt to have a clearance between the lid and the belt for preventing the lid from obstructing a rotation of the belt.

### 3. An electric cleaner comprising a cleaner body having a built-in electric blower for generating a suction airflow, 50 wherein the suction tool for electric cleaner of one of claims 1 and 2 communicates with the cleaner body. 55

FIG. 1

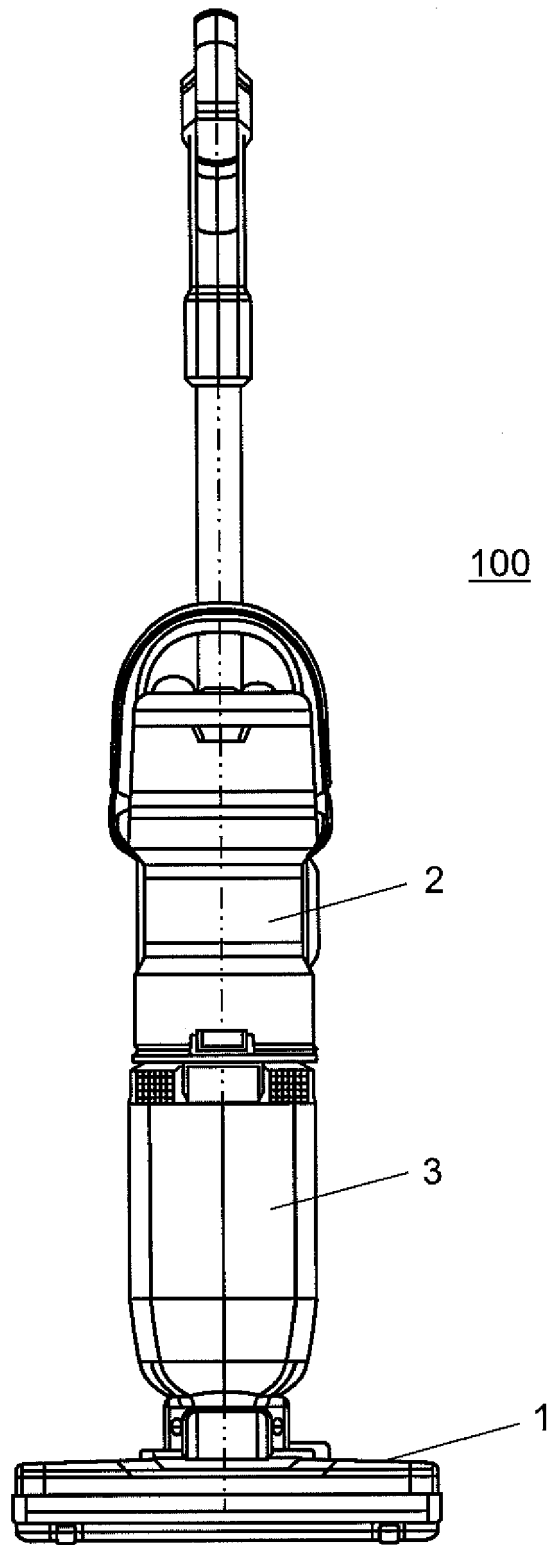

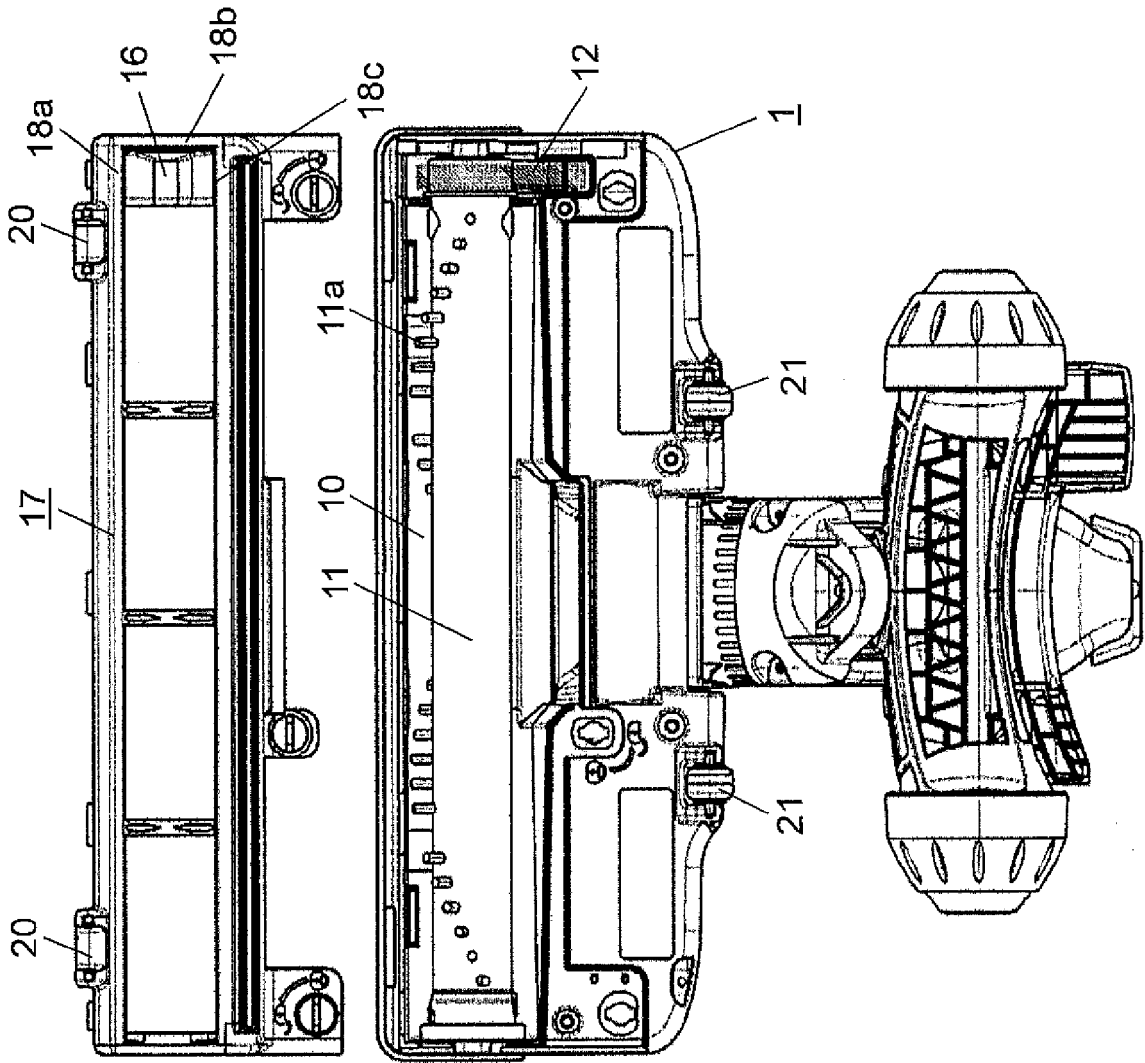

FIG. 2

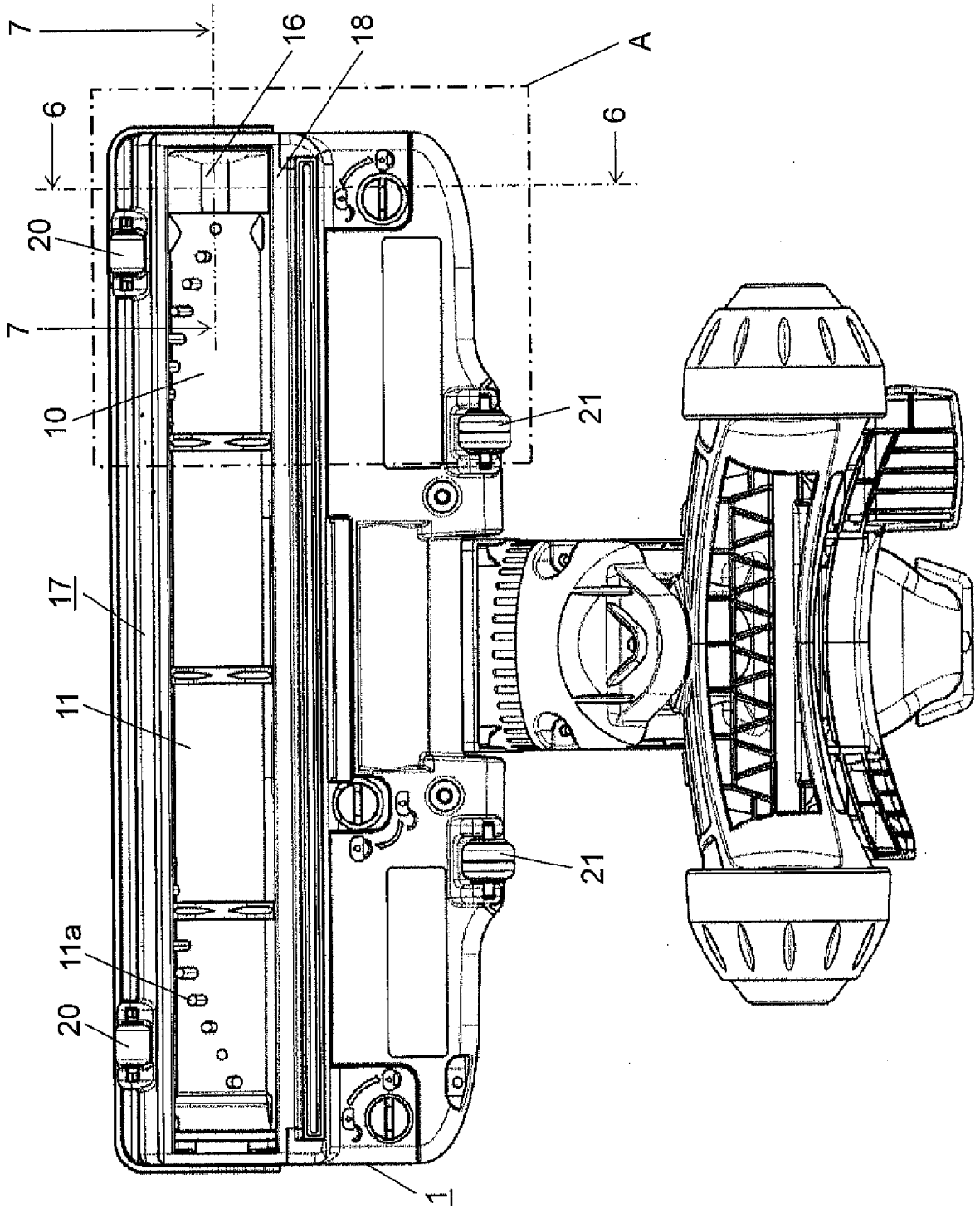

FIG. 3

FIG. 4

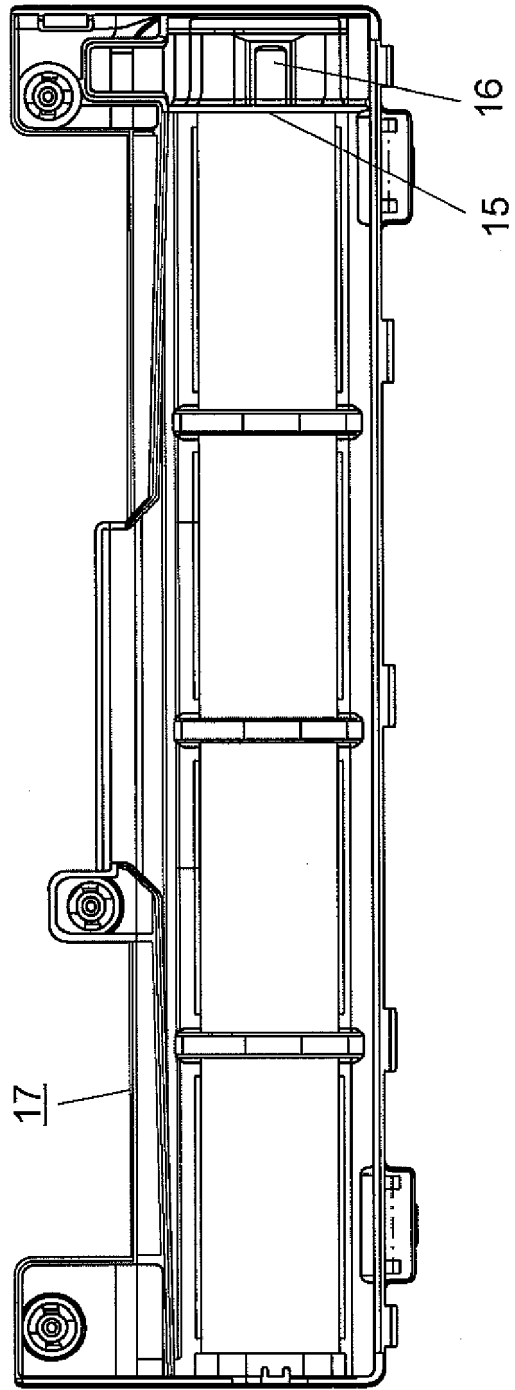

FIG. 5

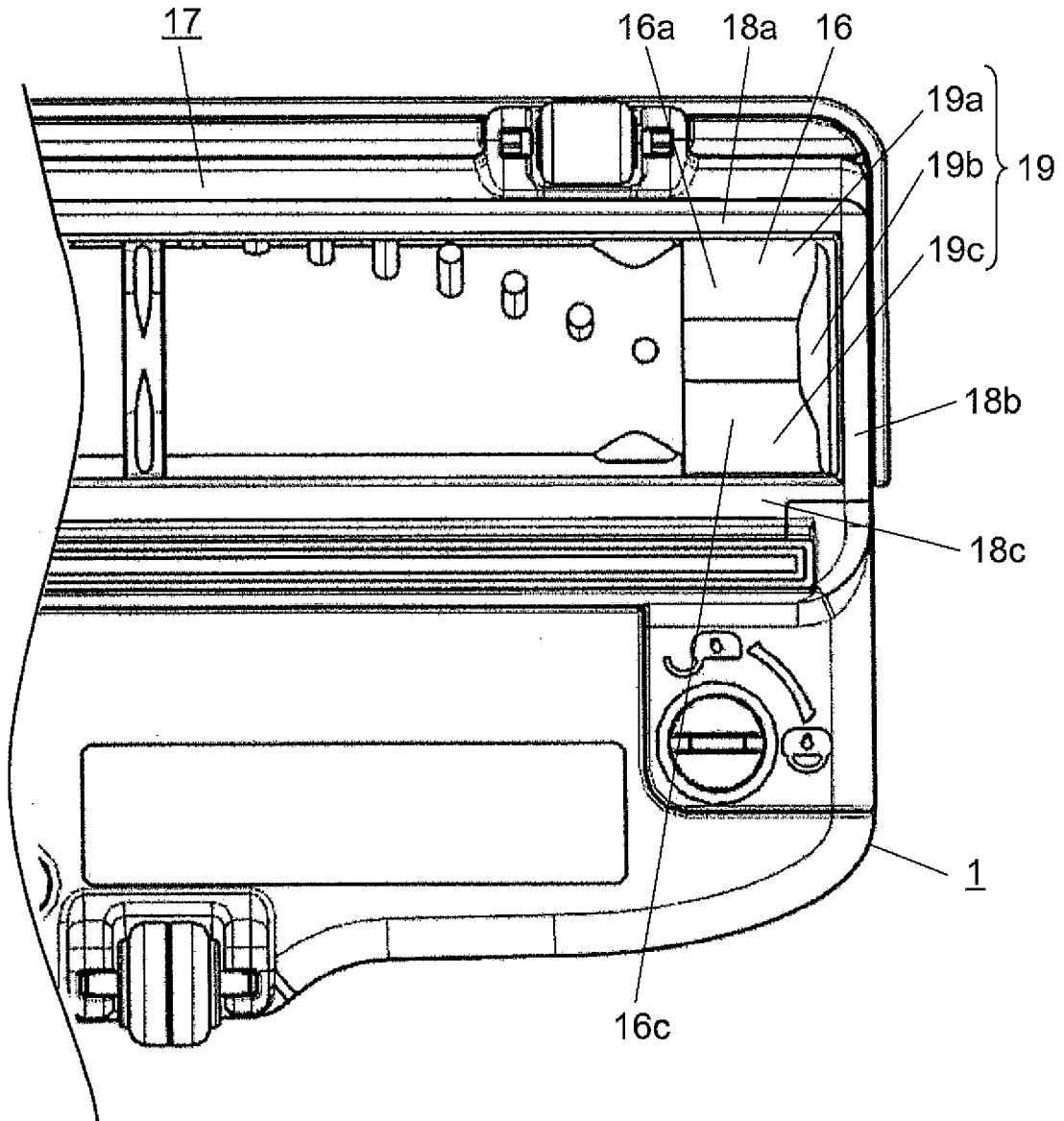
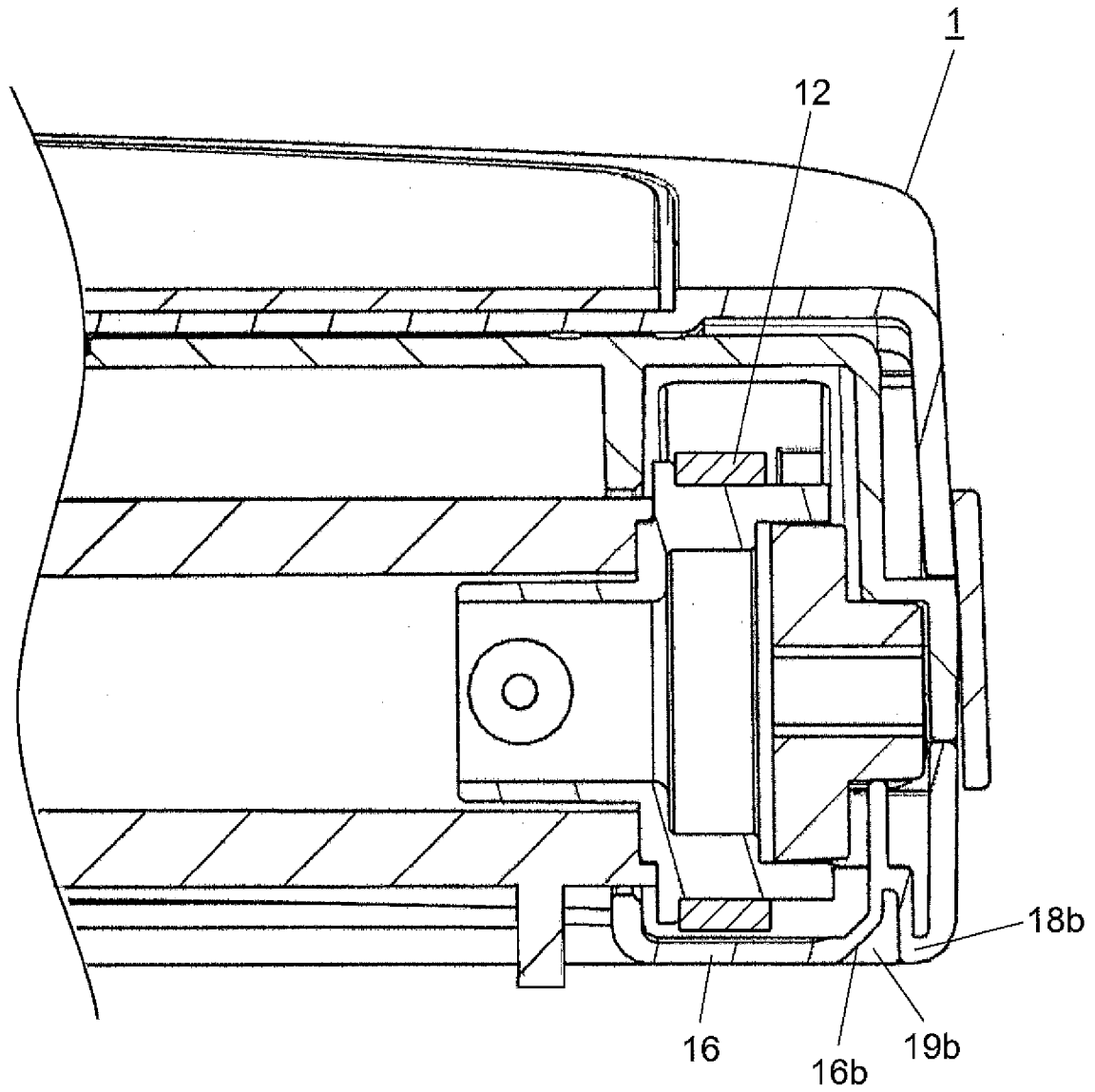



FIG. 7





EUROPEAN SEARCH REPORT

Application Number  
EP 15 16 9759

5

10

15

20

25

30

35

40

45

50

55

DOCUMENTS CONSIDERED TO BE RELEVANT			
Category	Citation of document with indication, where appropriate, of relevant passages	Relevant to claim	CLASSIFICATION OF THE APPLICATION (IPC)
X	GB 2 046 087 A (HITACHI LTD) 12 November 1980 (1980-11-12)	1,3	INV. A47L9/04
A	* page 2, line 84 - page 2, line 116; figures 4,5 *	2	
X	----- WO 2006/080383 A1 (TOSHIBA TEC KK [JP]; TAKAI YASUSHI [JP]; MORISHITA ATSUSHI [JP]; ICHIN) 3 August 2006 (2006-08-03)	1,3	
A	* paragraph [0033] - paragraph [0089]; figures 3,4 *	2	
-----			TECHNICAL FIELDS SEARCHED (IPC)
			A47L
The present search report has been drawn up for all claims			
Place of search Munich		Date of completion of the search 3 November 2015	Examiner Blumenberg, Claus
CATEGORY OF CITED DOCUMENTS		T : theory or principle underlying the invention E : earlier patent document, but published on, or after the filing date D : document cited in the application L : document cited for other reasons ..... & : member of the same patent family, corresponding document	
X : particularly relevant if taken alone Y : particularly relevant if combined with another document of the same category A : technological background O : non-written disclosure P : intermediate document			

1  
EPO FORM 1503 03/82 (P04/C01)

**ANNEX TO THE EUROPEAN SEARCH REPORT  
ON EUROPEAN PATENT APPLICATION NO.**

EP 15 16 9759

5

This annex lists the patent family members relating to the patent documents cited in the above-mentioned European search report. The members are as contained in the European Patent Office EDP file on The European Patent Office is in no way liable for these particulars which are merely given for the purpose of information.

03-11-2015

10

Patent document cited in search report	Publication date	Patent family member(s)	Publication date
GB 2046087 A	12-11-1980	DE 3012685 A1	16-10-1980
		GB 2046087 A	12-11-1980
		JP S6115683 B2	25-04-1986
		JP S55130633 A	09-10-1980
-----			
WO 2006080383 A1	03-08-2006	CN 101090660 A	19-12-2007
		JP 4468440 B2	26-05-2010
		KR 20070072915 A	06-07-2007
		WO 2006080383 A1	03-08-2006
-----			

15

20

25

30

35

40

45

50

55

EPO FORM P0459

For more details about this annex : see Official Journal of the European Patent Office, No. 12/82

**REFERENCES CITED IN THE DESCRIPTION**

*This list of references cited by the applicant is for the reader's convenience only. It does not form part of the European patent document. Even though great care has been taken in compiling the references, errors or omissions cannot be excluded and the EPO disclaims all liability in this regard.*

**Patent documents cited in the description**

- JP 2011036445 A [0003]