

(19) World Intellectual Property Organization
International Bureau



(43) International Publication Date
3 July 2008 (03.07.2008)

PCT

(10) International Publication Number
WO 2008/079616 A1

- (51) International Patent Classification:
B01L 3/00 (2006.01) *G01N 33/487* (2006.01)
- (21) International Application Number:
PCT/US2007/086575
- (22) International Filing Date:
6 December 2007 (06.12.2007)
- (25) Filing Language: English
- (26) Publication Language: English
- (30) Priority Data:
11/615,391 22 December 2006 (22.12.2006) US
- (71) Applicant (for all designated States except US): **ABBOTT
DIABETES CARE INC.** [US/US]; Alameda, CA 94502
(US).
- (72) Inventor; and
- (75) Inventor/Applicant (for US only): **WANG, Yi** [US/US];
521 Winding Brook Court, San Ramon, CA 94582 (US).
- (74) Agent: **KOWALCHYK, Katherine, M.**; Merchant &
Gould P.C., P.O. Box 2903, Minneapolis, MN 55402-0903
(US).

- (81) Designated States (unless otherwise indicated, for every kind of national protection available): AE, AG, AL, AM, AT, AU, AZ, BA, BB, BG, BH, BR, BW, BY, BZ, CA, CH, CN, CO, CR, CU, CZ, DE, DK, DM, DO, DZ, EC, EE, EG, ES, FI, GB, GD, GE, GH, GM, GT, HN, HR, HU, ID, IL, IN, IS, JP, KE, KG, KM, KN, KP, KR, KZ, LA, LC, LK, LR, LS, LT, LU, LY, MA, MD, ME, MG, MK, MN, MW, MX, MY, MZ, NA, NG, NI, NO, NZ, OM, PG, PH, PL, PT, RO, RS, RU, SC, SD, SE, SG, SK, SL, SM, SV, SY, TJ, TM, TN, TR, TT, TZ, UA, UG, US, UZ, VC, VN, ZA, ZM, ZW.
- (84) Designated States (unless otherwise indicated, for every kind of regional protection available): ARIPO (BW, GH, GM, KE, LS, MW, MZ, NA, SD, SL, SZ, TZ, UG, ZM, ZW), Eurasian (AM, AZ, BY, KG, KZ, MD, RU, TJ, TM), European (AT, BE, BG, CH, CY, CZ, DE, DK, EE, ES, FI, FR, GB, GR, HU, IE, IS, IT, LT, LU, LV, MC, MT, NL, PL, PT, RO, SE, SI, SK, TR), OAPI (BF, BJ, CF, CG, CI, CM, GA, GN, GQ, GW, ML, MR, NE, SN, TD, TG).

- Published:**
- with international search report
 - before the expiration of the time limit for amending the claims and to be republished in the event of receipt of amendments

(54) Title: ANALYTE SENSORS AND METHODS OF USE

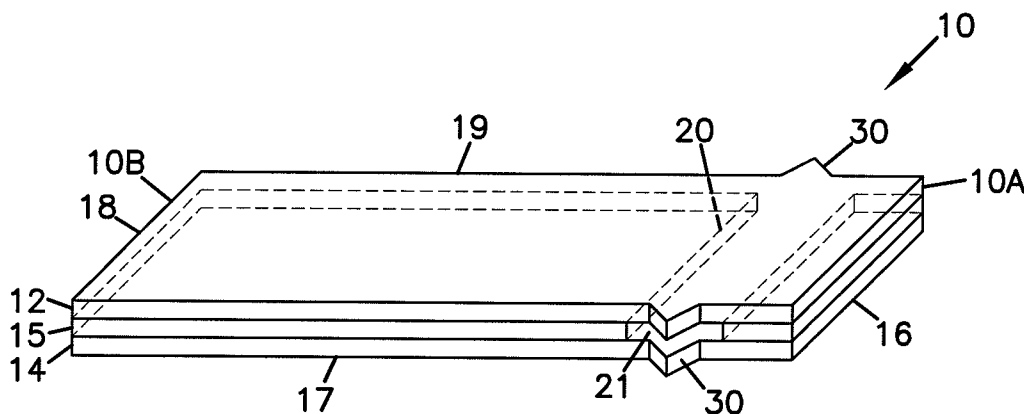

(57) Abstract: Analyte sensors for determining the concentration of an analyte in a sample. The sensors have a sample chamber having an inlet (21) with a projection (30) extending from an edge of the sensor for facilitating flow of sample into the sample chamber.

WO 2008/079616 A1

ANALYTE SENSORS AND METHODS OF USE

This application is being filed on 06 December 2007, as a PCT International Patent application in the name of ABBOTT DIABETES CARE INC, a U.S. national corporation, applicant for the designation of all countries except the U.S., and Yi
5 WANG, a citizen of the U.S., applicant for the designation of the U.S. only, and claims priority to U.S. Utility Patent Application Serial No. 11/615,391 filed on 22 December 2006.

FIELD OF THE INVENTION

This invention relates to analytical sensors for the detection of analyte in a
10 sample, and methods of making and using the sensors.

BACKGROUND

Biosensors, also referred to as analytical sensors or merely sensors, are commonly used to determine the presence and concentration of a biological analyte in a sample. Such biosensors are used, for example, to monitor blood glucose levels
15 in diabetic patients.

As sensors continue to be used, there continues to be an interest in sensors that are easy to manufacture and easy for a patient to use.

SUMMARY

The present disclosure provides sensors and methods for the detection and
20 quantification of an analyte in a sample. The sensors have an inlet to the sample chamber that facilitates drawing of sample (e.g., blood) into the chamber. The sensors include an element that provides an open path to the sample chamber and that inhibits restriction of the inlet by the patient's skin.

In general, certain embodiments of the invention include sensors for analysis
25 of an analyte in a sample, e.g., a small volume sample, by, for example, coulometry, amperometry and/or potentiometry. The sensors include at least a working electrode and a counter electrode, which may be on the same substrate (e.g., co-planar) or may be on different substrates (e.g., facing). Sensing chemistry may be present on the electrode(s). The sensors also include a sample chamber to hold the sample in
30 electrolytic contact with the working electrode. An inlet, present in an edge of the sensor, provides fluid communication to the sample chamber. The sensors may be

configured for side-filling or tip-filling. In addition, in some embodiments, the sensor may be part of an integrated sample acquisition and analyte measurement device. An integrated sample acquisition and analyte measurement device may include a sensor and a skin piercing member, so that the device can be used to pierce
5 the skin of a user to cause flow of a fluid sample, such as blood, that may then be collected by the sensor.

In one particular aspect, the disclosure is directed to an analyte sensor for determining the concentration of an analyte in a sample, the sensor comprising a sample chamber having an inlet with a width and an element such as projection
10 extending from an edge of the sensor, the projection having a height and a width. The width of the projection may be the same or more than the inlet width, or may be less than the inlet width, e.g., no more than about 80% of the inlet width, e.g., no more than about 75% or about 50% of the inlet width. The average projection width may be no more than about 50% of the inlet width, or no more than about 40%. The
15 height of the projection may be at least about 0.1 mm or at least about 0.2 mm. The projection may extend from a side edge of the substrate or from an end edge of the substrate. In some embodiments, the sensor includes a second projection.

In another particular aspect, the disclosure is directed to an analyte sensor having a first substrate, a second substrate, and a spacer layer therebetween, with a
20 sample chamber defined between the first substrate and the second substrate bounded by the spacer layer. The sample chamber has at least one inlet, and a protrusion extending from the first substrate at the inlet. The sensor may include second, third and/or fourth protrusions.

In yet another particular aspect, the disclosure is directed to an analyte sensor
25 for determining the concentration of an analyte in a sample, the sensor having a first substrate and a second substrate each having a first side edge and a second side edge, a sample chamber defined between the first substrate and the second substrate, with the sample chamber extending from the first side edge to the second side edge, a first aperture and a second aperture between the first substrate and the second
30 substrate at the first side edge and the second side edge, respectively, and a first projection and a second projection extending from the first side edge of the first substrate and the second side edge of the first substrate, respectively, proximate the apertures, each of the projections having a width less than the width of the proximate aperture. The sensor may additional have a third projection and a fourth projection

extending from the first side edge of the second substrate and the second side edge of the second substrate, respectively, proximate the apertures. The maximum width of the projection may be no more than about 80% of the aperture width, e.g., no more than about 75% or about 50% of the aperture width. The average projection
5 width may be no more than about 50% of the inlet width, or no more than about 40%. The height of the projections may be at least about 0.1 mm or at least about 0.2 mm.

The sensors may have a sample chamber volume of no more than about 1 microliter, and in some embodiments, a volume of no more than about 0.5
10 microliter.

Methods of using the sensors include determining the concentration of glucose.

These and various other features which characterize the invention are pointed out with particularity in the attached claims. For a better understanding of the
15 invention, its advantages, and objectives obtained by its use, reference should be made to the drawings and to the accompanying description, in which there is illustrated and described preferred embodiments of the invention.

BRIEF DESCRIPTION OF THE DRAWINGS

Referring now to the drawings, wherein like reference numerals and letters
20 indicate corresponding structure throughout the several views:

FIG. 1A is a schematic perspective view of a first embodiment of a sensor strip in accordance with the present invention;

FIG. 1B is an exploded view of the sensor strip of FIG. 1A, the layers illustrated individually with the electrodes in a first configuration;

25 FIG. 2A is a schematic view of a second embodiment of a sensor strip in accordance with the present invention;

FIG. 2B is an exploded view of the sensor strip of FIG. 2A, the layers illustrated individually with the electrodes in a second configuration;

30 FIG. 3A is a schematic top view of a third embodiment of a sensor strip in accordance with the present invention;

FIG. 3B is a schematic top view of a fourth embodiment of a sensor strip in accordance with the present invention; and

FIG. 4 is an enlarged top plan view of a portion of a sensor strip according to

the present invention.

DETAILED DESCRIPTION

This disclosure provides sensors and methods of making and using those sensors that facilitate the drawing of fluid sample (e.g., blood) into the sensor by
5 inhibiting contact of the patient's skin with the sample inlet.

Referring to the Drawings in general and FIGS. 1A and 1B in particular, a first embodiment of a sensor 10 is schematically illustrated, herein shown in the shape of a strip. It is to be understood that the sensor may be any suitable shape. Sensor strip 10 has a first substrate 12, a second substrate 14, and a spacer 15
10 positioned therebetween. Sensor strip 10 is a layered construction.

Sensor strip 10 includes at least one working electrode 22 and at least one counter electrode 24. Although not illustrated, sensor strip 10 may also include an optional fill indicator electrode and/or an optional insertion monitor.

Sensor strip 10 has a first, distal end 10A and an opposite, proximal end 10B. At distal end 10A, sample to be analyzed is applied to sensor 10. Distal end 10A could be referred to as 'the fill end', 'sample receiving end', or similar. Proximal end 10B of sensor 10 is configured for operable, and usually releasable, connecting to a device such as a meter. Sensor strip 10, in
15 certain embodiments, has a generally rectangular shape, i.e., its length is longer than its width, although other shapes 10 are possible as well, as noted above. Sensor strip 10 has four edges, end edge 16 at distal end 10A, end edge 18 at proximal end 10, and side edges 17, 19 extending therebetween.
20

The dimensions of a sensor may vary. In certain embodiments, the overall length of sensor strip 10, from end edge 16 to end edge 18, may be no less than
25 about 10 mm and no greater than about 50 mm. For example, the length may be between about 30 and 45 mm; e.g., about 30 to 40 mm. It is understood, however that shorter and longer sensor strips 10 could be made. In certain embodiments, the overall width of sensor strip 10, from side edge 17 to side edge 19, may be no less
30 than about 3 mm and no greater than about 15 mm. For example, the width may be between about 4 and 10 mm, about 5 to 8 mm, or about 5 to 6 mm. In one particular example, sensor strip 10 has a length of about 32 mm and a width of about 6 mm. In another particular example, sensor strip 10 has a length of about 40 mm and a width

of about 5 mm. In yet another particular example, sensor strip 10 has a length of about 34 mm and a width of about 5 mm.

The sensor includes a sample chamber for receiving a volume of sample to be analyzed; in the embodiment illustrated, particularly in FIG. 1A, sensor strip 10 includes sample chamber 20 having an inlet 21 for access to sample chamber 20. In the embodiment illustrated, sensor strip 10 is a side-fill sensor strip, having inlet 21 present on side edge 17 of strip 10. In this embodiment, sensor strip 10 has a second inlet at side edge 19 (not seen). Tip-fill sensors, having an inlet at, for example, end edge 16, are also within the scope of this disclosure, as well as corner fill sensors.

Proximate inlet 21, sensor strip 10 includes an element for facilitating the drawing of fluid sample (e.g., blood) into sensor strip 10 by inhibiting contact of the patient's skin with sample inlet 21. Sensor strip 10 includes a projection 30 extending outward from at least one of substrates 12, 14 in the location of inlet 21. In this embodiment, projection 30 is present on both substrates, substrate 12 and substrate 14, and on both side edges, edge 17 and edge 19. Additional discussion of projection 30 is provided below. In some embodiments, the element (e.g., projection 30) may facilitate the drawing of fluid sample (e.g., blood) into sensor strip 10 by capillary fluid flow mechanism.

Referring to FIGS. 2A and 2B, an alternate embodiment of a sensor is illustrated as sensor strip 110. Similar to sensor strip 10, sensor strip 110 has a first substrate 112, a second substrate 114, and a spacer 115 positioned therebetween. Sensor strip 110 includes at least one working electrode 122 and at least one counter electrode 124, in this embodiment, both on substrate 114.

Sensor strip 110 has a first, distal end 110A and an opposite, proximal end 110B. At distal end 110A, sample to be analyzed is applied to sensor 110. Distal end 110A could be referred as 'the fill end', 'sample receiving end', or similar. Proximal end 110B of sensor 110 is configured for operable, and preferably releasable, connecting to a device such as a meter. Similar to sensor strip 10, sensor strip 110 is a layered construction, in certain embodiments having a generally rectangular shape, which is formed by first and second substrates 112, 114 and defined by end edges 116, 118 and side edges 117, 119. The discussion above about substrates 12, 14 and spacer 15 and the various features applies to substrates 112, 114 and spacer 115 and the various features.

Similar to sample chamber 20 of sensor strip 10, sensor strip 110 includes sample chamber 120 defined by substrate 112, substrate 114 and spacer 115. Sample chamber 120 includes an inlet 121 for access to sample chamber 120. Sensor strip 110 is a tip-fill sensor, having inlet 121 in end edge 116 at end 110A. Extending from sample chamber 120, through substrate 112, is a vent 125. The discussion above about sample chamber 20 and its measurement zone also applies to sample chamber 120.

Proximate inlet 121, sensor strip 110 includes an element for facilitating the drawing of fluid sample (e.g., blood) into sensor strip 110 by inhibiting contact of the patient's skin with sample inlet 121. Sensor strip 110 includes a projection 130 extending outward from at least one of substrates 112, 114 in the location of inlet 121. In this embodiment, projection 130 is present on only one substrate, substrate 112. Additional discussion of projection 130 is provided below.

Referring to FIGS. 3A and 3B, two other alternate embodiments of sensors are illustrated as sensor strips 210, 210', respectively. Similar to sensor strips 10, 110 discussed before, sensor strips 210, 210' have a first substrate, a second substrate, and a spacer positioned therebetween. Sensor strips 210, 210' include at least one working electrode and at least one counter electrode.

Sensor strips 210, 210' have a first, distal end 210A, 210A' and an opposite, proximal end 210B, 210B'. Similar to sensor strips 10, 110, sensor strips 210, 210' are layered constructions, in this embodiment, having a generally rectangular shape with a width at proximal end 210B, 210B' and a reduced width closer to distal end 210A, 210A'. The shape of sensor strip 210, 210' is defined by end edges 216, 216', 218, 218' and side edges 217, 217', 219, 219'. Each of side edges 217, 217', 219, 219' has a first portion where edges 217A, 217A', 219A, 219A' are recessed or reduced (e.g., the sensor width is reduced in the first portion) as compared to a second portion, defined by edges 217B, 217B', 219B, 219B', where the width is the entire width of the sensor.

Edges 217A, 217A', 219A, 219A' in the first portion may have generally any shape, such as linear, arcuate (e.g., concave or convex), or irregular. Sections of the portion may have side edges 217A, 217A', 219A, 219A' angled (e.g., tapered) or parallel to each other. Strip 210, of FIG. 3A, has non-parallel, arcuate edges 217A, 219A in the first portion, whereas strip 210' of FIG. 3B has generally parallel, generally linear edges 217A', 219A', having an arcuate transition region proximate

edges 217B', 219B'. Having a recessed or reduced portion, such as defined by edges 217A, 217A', 219A, 219A', facilitates differentiating distal end 210A, 210A' from proximal end 210B, 210B'.

5 Similar to the previous sensor embodiments, sensor strips 210, 210' include a sample chamber 220, 220' defined by the substrates and the spacer. Sample chambers 220, 220' include an inlet 221, 221' for access thereto. Sensor strips 210, 210' are side-fill sensors, having two inlets 221, 221', one in edge 217A, 217A' and one in edge 219A, 219A' proximate end 210A, 210A'.

10 Proximate inlet 221, 221', sensor strips 210, 210' include an element for facilitating the drawing of fluid sample (e.g., blood) into sensor strips 210, 210' by inhibiting contact of the patient's skin with sample inlet 221, 221'. Sensor strips 210, 210' include a projection 230, 230' extending outward from at least one of substrates in the location of inlet 221, 221'. In this embodiment, projection 230, 230' is present on only one substrate, substrate, at both inlets 221. Additional discussion of
15 projection 230, 230' is provided below.

The following detailed discussion applies to both sensor strip 10 and sensor strips 110, 210, 210' and their various elements and features. Although the following discussion usually uses the references numerals for sensor strip 10 (e.g., substrates 12, 14, sample chamber 20, inlet 21, etc.), it is to be understood that this
20 discussion applies to both embodiments, i.e., sensor strip 10, sensor strip 110 and sensor strips 210, 210'.

Substrates and Spacer

25 As provided above, sensor strip 10 has first and second substrates 12, 14, non-conducting, inert substrates which form the overall shape and size of sensor strip 10. The substrates may be substantially rigid or substantially flexible. In certain embodiments, the substrates are flexible or deformable. Examples of suitable materials for the substrates include, but are not limited, to polyester, polyethylene, polycarbonate, polypropylene, nylon, and other "plastics" or
30 polymers. In certain embodiments the substrate material is "Melinex" polyester. Other non-conducting materials may also be used.

As indicated above, positioned between substrate 12 and substrate 14 may be spacer 15 to separate first substrate 12 from second substrate 14. In some embodiments, spacer 15 extends from end 10A to end 10B of the sensor strip, or

extends short of one or both ends. The spacer is an inert non-conducting substrate, typically at least as flexible and deformable (or as rigid) as the substrates. In certain embodiments, the spacer is an adhesive layer or double-sided adhesive tape or film that is continuous and contiguous. Any adhesive selected for the spacer should be selected to not diffuse or release material which may interfere with accurate analyte measurement.

In certain embodiments, the thickness of the spacer may be constant throughout, and may be at least about 0.01 mm (10 μm) and no greater than about 1 mm or about 0.5 mm. For example, the thickness may be between about 0.02 mm (20 μm) and about 0.2 mm (200 μm). In one certain embodiment, the thickness is about 0.05 mm (50 μm), and about 0.1 mm (100 μm) in another embodiment.

Sample Chamber

The sensor includes a sample chamber for receiving a volume of sample to be analyzed; access to the sample chamber is provided via an inlet. The sample chamber is configured so that when a sample is provided in the chamber, the sample is in electrolytic contact with both a working electrode and a counter electrode, which allows electrical current to flow between the electrodes to effect the electrolysis (electrooxidation or electroreduction) of the analyte.

Sample chamber 20 is defined by substrate 12, substrate 14 and spacer 15; in many embodiments, sample chamber 20 exists between substrate 12 and substrate 14 where spacer 15 is not present. Typically, a portion of the spacer is removed to provide a volume between the substrates without the spacer; this volume of removed spacer is the sample chamber. For embodiments that include a spacer between the substrates, the thickness of the sample chamber is generally the thickness of the spacer.

The sample chamber has a volume sufficient to receive a sample of biological fluid therein. In some embodiments, such as when a sensor is a small volume sensor, the sample chamber has a volume that is typically no more than about 1 μL , for example no more than about 0.5 μL , and also for example, no more than about 0.25 μL . A volume of no more than about 0.1 μL is also suitable for the sample chamber, as are volumes of no more than about 0.05 μL and about 0.03 μL .

A measurement zone is contained within the sample chamber and is the region of the sample chamber that contains only that portion of the sample that is

interrogated during the analyte assay. In some designs, the measurement zone has a volume that is approximately equal to the volume of the sample chamber. In some embodiments the measurement zone includes 80% of the sample chamber, 90% in other embodiments, and about 100% in yet other embodiments.

5 As provided above, the thickness of the sample chamber corresponds typically to the thickness of any spacer. Particularly for facing electrode configurations, as in the sensor illustrated in FIG. 1B, this thickness is small to promote rapid electrolysis of the analyte, as more of the sample will be in contact with the electrode surface for a given sample volume. In addition, a thin sample
10 chamber helps to reduce errors from diffusion of analyte into the measurement zone from other portions of the sample chamber during the analyte assay, because diffusion time is long relative to the measurement time, which may be about 5 seconds or less.

15 Electrodes

The sensor includes a working electrode and at least one counter electrode. The counter electrode may be a counter/reference electrode. If multiple counter electrodes are present, one of the counter electrodes will be a counter electrode and one or more may be reference electrodes.

20 For sensor 10, at least one working electrode is positioned on one of first substrate 12 and second substrate 14 in the measurement zone and/or sample chamber. In FIG. 1B, working electrode 22 is illustrated on substrate 12. Working electrode 22 extends from the sample chamber 20, proximate distal end 10A, to the other end of the sensor 10, end 10B, as an electrode extension called a "trace". The
25 trace provides a contact pad for providing electrical connection to a meter or other device to allow for data and measurement collection.

For sensor 110, at least one working electrode is positioned on one of first substrate 112 and second substrate 114 in the measurement zone and/or sample chamber. In FIG. 2B, working electrode 122 is illustrated on substrate 114.
30 Working electrode 122 extends from the sample chamber, proximate distal end 110A, to the other end of the sensor 110, end 110B, as an electrode extension called a "trace". The trace provides a contact pad for providing electrical connection to a meter or other device to allow for data and measurement collection.

Working electrode 22, 122 may be a layer of conductive material such as

gold, carbon, platinum, ruthenium dioxide, palladium, or other non-corroding, conducting material. The working electrode may be a combination of two or more conductive materials. An example of a suitable conductive epoxy is ECCOCOAT CT5079-3 Carbon-Filled Conductive Epoxy Coating (available
5 from W.R. Grace Company, Woburn, MA). The material of the working electrode typically has relatively low electrical resistance and is typically electrochemically inert over the potential range of the sensor during operation.

The working electrode may be applied on the substrate by any of various methods, including by being deposited, such as by vapor deposition or vacuum
10 deposition or otherwise sputtered, printed on a flat surface or in an embossed or otherwise recessed surface, transferred from a separate carrier or liner, etched, or molded. Suitable methods of printing include screen-printing, piezoelectric printing, ink jet printing, laser printing, photolithography, and painting.

The sensor also includes at least one counter electrode positioned within the
15 measurement zone and/or sample chamber. In FIG. 1B, counter electrode 24 is illustrated on substrate 14. Counter electrode 24 extends from the sample chamber 20, proximate first end 10A, to the other end of the sensor 10, end 10B, as an electrode extension called a "trace". The trace provides a contact pad for providing electrical connection to a meter or other device to allow for data and measurement
20 collection. In FIG. 2B, counter electrode 124 is illustrated on substrate 114. Counter electrode 124 extends from the sample chamber, proximate first end 110A, to the other end of the sensor 110, end 110B, as an electrode extension called a "trace". The trace provides a contact pad for providing electrical connection to a meter or other device to allow for data and measurement collection.

Counter electrodes 24, 124 may be constructed in a manner similar to
25 working electrodes 22, 122. Suitable materials for the counter/reference or reference electrode include Ag/AgCl or Ag/AgBr on a non-conducting base material or silver chloride on a silver metal base. The same materials and methods may be used for the counter electrode as are available for the working electrode, although different
30 materials and methods may also be used. The counter electrode may include a mix of multiple conducting materials, such as Ag/AgCl and carbon.

The working electrode and counter electrode may be positioned opposite to and facing each other to form facing electrodes. See for example, FIG. 1B, which has working electrode 22 on substrate 12 and counter electrode 24 on substrate 14,

forming facing electrodes. In this configuration, the sample chamber is typically present between the two electrodes 22, 24. In other embodiments, the working electrode and counter electrode may be positioned generally planar to one another, such as on the same substrate, to form co-planar or planar electrodes. See for
5 example, FIG. 2B, which has both working electrode 122 and counter electrode 124 on substrate 114, forming planar electrodes.

In some instances, it is desirable to be able to determine when the sample chamber of the sensor is sufficiently filled with sample. Sensor strip 10 may be indicated as filled, or substantially filled, by observing a signal between an optional
10 indicator (or fill) electrode and one or both of working electrode 22 or counter electrode 24 as sample chamber 20 fills with fluid. When fluid reaches the indicator electrode, the signal from that electrode will change. Suitable signals for observing include, for example, voltage, current, resistance, impedance, or capacitance between the indicator electrode and, for example, working electrode 22.

15 Alternatively, the sensor may be observed after filling to determine if a value of the signal (e.g., voltage, current, resistance, impedance, or capacitance) has been reached indicating that the sample chamber is filled.

For side-fill sensors, such as sensor 10 of FIGS. 1A and 1B and sensor 210 of FIG. 3, an indicator electrode may be present on each side of the counter
20 electrode. This permits the user to fill the sample chamber from either the left or right side with an indicator electrode disposed further upstream. This three-electrode configuration is not necessary. Side-fill sensors may also have a single indicator electrode and may include some indication as to which side should be placed in contact with the sample fluid.

25 The indicator electrode may also be used to improve the precision of the analyte measurements. The indicator electrode may operate as a working electrode or as a counter electrode or counter/reference electrode. Measurements from the indicator electrode/working electrode may be combined (e.g., added or averaged) with those from the first counter/reference electrode/working electrode to obtain
30 more accurate measurements.

The sensor or equipment that the sensor connected is with (e.g., a meter) may include a signal (e.g., a visual sign or auditory tone) that is activated in response to activation of the indicator electrode to alert the user that the desired zone has been filled. The sensor or equipment may be configured to initiate a

reading when the indicator electrode indicates that the measurement zone has been filled with or without alerting the user. The reading may be initiated, for example, by applying a potential between the working electrode and the counter electrode and beginning to monitor the signals generated at the working
5 electrode.

Sensing Chemistry

In addition to working electrode 22, sensing chemistry material(s) are preferably provided in sample chamber 20 for the analysis of the analyte. Sensing
10 chemistry material facilitates the transfer of electrons between working electrode 22 and the analyte in the sample. Any sensing chemistry may be used in the sensor; the sensing chemistry may include one or more materials.

The sensing chemistry may be diffusible or leachable, or non-diffusible or non-leachable. For purposes of discussion herein, the term "diffusible" will be used
15 to represent "diffusible or leachable" and the term "non-diffusible" will be used to represent "non-diffusible or non-leachable" and variations thereof. Placement of sensing chemistry components may depend on whether they are diffusible or not. For example, both non- diffusible and/or diffusible component(s) may form a sensing layer on the working electrode. Alternatively, one or more diffusible
20 components may be present on any surface in the sample chamber prior to the introduction of the sample to be analyzed. As another example, one or more diffusible component(s) may be placed in the sample prior to introduction of the sample into the sample chamber.

The sensing chemistry generally includes an electron transfer agent that
25 facilitates the transfer of electrons to or from the analyte. The electron transfer agent may be diffusible or non-diffusible, and may be present on working electrode 22 as a layer. One example of a suitable electron transfer agent is an enzyme which catalyzes a reaction of the analyte. For example, a glucose oxidase or glucose dehydrogenase, such as pyrroloquinoline quinone glucose dehydrogenase (PQQ), is
30 used when the analyte is glucose. Other enzymes may be used for other analytes.

The electron transfer agent, whether it is diffusible or not, facilitates a current between the working electrode and the analyte and enables the electrochemical analysis of molecules. The agent facilitates the transfer electrons between the electrode and the analyte.

This sensing chemistry may, additionally to or alternatively to the electron transfer agent, include a redox mediator. Certain embodiments use a redox mediator that is a transition metal compound or complex. Examples of suitable transition metal compounds or complexes include osmium, ruthenium, iron, and cobalt compounds or complexes. In these complexes, the transition metal is coordinatively bound to one or more ligands, which are typically mono-, di-, tri-, or tetradentate. The redox mediator may be a polymeric redox mediator or a redox polymer (i.e., a polymer having one or more redox species). Examples of suitable redox mediators and redox polymers are disclosed in U.S. Patent No. 6,338,790, for example, and in U.S. Patent Nos. 6,605,200 and 6,605,201.

If the redox mediator is non-diffusible, then the redox mediator may be present on the working electrode as a layer. In an embodiment having a redox mediator and an electron transfer agent, if the redox mediator and electron transfer agent are both non-leachable, then both components are on the working electrode as individual layers, or combined and applied as a single layer.

The redox mediator, whether diffusible or not, mediates a current between the working electrode and the analyte and enables the electrochemical analysis of molecules which may not be suited for direct electrochemical reaction on an electrode. The mediator functions as an agent to transfer electrons between the electrode and the analyte.

In accordance with this disclosure, sensors, such as sensor strips 10, 110, 210, 210' include projection 30, 130, 230, 230' for facilitating the drawing of fluid sample (e.g., blood) into the sensor by inhibiting contact of the patient's skin with the sample inlet. Projection 30 is an element extending outward from at least one of substrates 12, 14 in the location of sample chamber inlet 21. Projection 30 extends out from the edge in which the inlet is present. For example, projection 30 extends out from edge 17 and edge 19 of both substrates 12, 14; projection 130 extends out from edge 116 of substrate 112; and projections 230, 230' extend out from edges 217A, 217A', 219A, 219A'.

Referring to FIG. 4, a generic projection is illustrated. This may be projection 30 extending from edge 17 or from edge 19, projection 130 extending from edge 116, projection 230 extending from edge 217A or edge 219A, or projection 230' extending from edge 217A' or edge 219A'. However to facilitate discussion, the projection in FIG. 4 will be referred to as projection 30 ending from

edge 17, although it should be understood that the project and edge could be any of those described herein. Similarly, to facilitate discussion, the inlet will be referred to as inlet 21.

Projection 30 extends from edge 17 at inlet 21. Projection 30 may be additionally or alternately referred to as an outward notch, a protrusion, an overhang, a cantilever, a tab, or other similar term that describes an element extending out from the sensor. Projection 30 inhibits blocking or sealing of inlet 21 by the skin of the sensor user. The small protrusion of projection 30 out from edge 17 inhibits the user's skin from blocking the inlet and maintains a passage between the skin and inlet 21 for fluid sample to flow to the sample chamber. Additionally, projection 30 may function as a visual and/or tactile indicator to the user as to the location of inlet 21.

For layered sensors, such as sensor strips 10, 110, 210, projection 30 can be present on both substrates (e.g., substrates 12, 14) or only one substrate.

The shape and size of projection 30 is selected so that the user's skin cannot readily conform around projection 30, thus blocking access to inlet 21 between the substrates.

Projection 30 has a width W , measured in the same direction as a width X of inlet 21. In this embodiment, inlet 21 has the same width X as its sample chamber. In some embodiments, projection 30 may extend over the entire width X of inlet 21; i.e., width W is the same or more than width X . In other embodiments however, the maximum width W of projection 30 is less than width X of inlet 21, and in this embodiment, less than the width of the sample chamber. It is understood that in some embodiments, the width of the sample chamber may be greater or smaller than width X of inlet 21. The maximum width W of projection 30, in some embodiment, is no more than 80% of width X of inlet 21, often no more than 75%. In some embodiments, the maximum width W is no more than 70% of width X . In other embodiments, the maximum width W is no more than 60% of width X . In still other embodiments, the maximum width W is no more than 50% of the width X of inlet 21. In other embodiments, the average width W of projection 30 is no more than 50% of width X . For example, the average width W is no more than 45% of width X , and in some embodiments no more than 40% of width X . In some embodiments, maximum width W is no more than about 1.5 mm, e.g., no more than about 1 mm, e.g., no more than about 0.5 mm.

Projection 30 also has a height, the distance from side edge 17 that projection 30 extends. Height H of projection 30 is at least 0.1 mm, often at least 0.2 mm, e.g., at least 0.3 mm. Typically, the larger the height H, the better the passage created due to projection 30.

5 The ratio of width W to height H, in some embodiments, is about 2:1 to about 1:2. In other embodiments, the ratio of width W to height H is about 1.5:1 to about 1:1.5.

10 In the illustrated embodiment of FIG. 4, projection 30 has a triangular shape, with its base even with edge 17 and its apex pointing away from inlet 21. In some embodiments, the apex may be defined by a radius. Other configurations for projection 30 are suitable, such as rectangular (including square), arcuate (e.g., semi-circular), pentagon, etc. Geometric shapes could have arcuate sides; for example, a substantially triangular or triangular-like projection could have arcuate (e.g., concave or convex) sides; other shapes could additionally have arcuate side(s).

15 Projection 30 may be symmetrical or unsymmetrical. In some embodiments, however, projection 30 has an apex or point extending away from inlet 21; the apex may have a radius associate with it. Geometric shapes such as triangles, pentagons, etc., have an apex. A configuration such as projection 30 provides a small area (e.g., a point) for contacting the skin of the sensor user.

20 In some embodiments, the extension or cantilever of projection 30 out from edge 17 facilitates drawing of sample into inlet 21 and the sample chamber. Details regarding using a cantilevered sensor for facilitating sample flow are discussed in co-pending application 11/237,447 filed September 27, 2005.

25 In one particular exemplary embodiment, a triangular projection 30 has a height H of about 0.38 mm (15 mil) and a width W of about 0.5 mm (20 mil), whereas inlet 21 has a width X of about 1 mm (40 mil). In this embodiment, projection 30 has a width that is about 50% of the inlet width. The ratio of width W to height H is 4:3, or, about 1.33:1.

30 Various specific configurations of sensors having projections are illustrated in U.S. Design patent application no. 29/275,392, the entire disclosure of which is incorporated herein by reference.

General Method for Manufacturing Sensors

Sensor strips 10, 110, 210, 210' discussed above, are sandwiched or layered

constructions having substrates 12, 14, 112, 114 spaced apart, such as by spacer 15, 115. Such a construction may be made by laminating the various layers together, in any suitable manner. Projection 30, 130, etc. may be formed on substrate(s) 12, 14, etc. before lamination, or, the overall shape of sensor strips 10, 110, etc. may be
5 formed (e.g., punched) after lamination of the various layers together. An alternate method for making sensor strips 10, 110, 210, 210' and other sensors in accordance with the invention, is to mold the sensors.

Molding may include positioning at least two spaced apart electrically conductive electrodes (e.g., wires) in a mold, and molding a body of insulative
10 material around the electrodes, with one end having therein means for receiving a fluid sample. More specifically, molding could include positioning at least two spaced apart electrically conductive electrodes (e.g., wires) in a mold, before or after molding, treating at least one of the electrodes with one or more chemicals to change the electrical properties of the treated electrode upon contact with a fluid
15 sample, and molding a body of insulative material around the electrodes with one end having therein means for receiving a fluid sample. The body may be molded in multiple pieces, e.g., two pieces, with a body and end cap for attaching to one another after the molding is completed, or in a single piece.

A sensor may be made by positioning electrodes on one or more
20 substrates, the substrates including a first substrate, optionally contacting at least a portion of at least one electrode with sensing material(s), and configuring the sensor by positioning a spacer between the two substrates to maintain the substrates in a fixed, layered orientation relative to each other.

25 Application of the Sensors

A common use for a sensor of the present invention, such as sensor strip 10, 110, 210, 210' is for the determination of analyte concentration in a biological fluid, such as glucose concentration in blood, interstitial fluid, and the like, in a patient or other user. Additional analytes that may be determined include but are not limited to,
30 for example, acetyl choline, amylase, bilirubin, cholesterol, chorionic gonadotropin, creatine kinase (e.g., CK-MB), creatine, DNA, fructosamine, glucose, glutamine, growth hormones, hormones, ketones, lactate, peroxide, prostate-specific antigen, prothrombin, RNA, thyroid stimulating hormone, and troponin. The concentration of drugs, such as, for example, antibiotics (e.g., gentamicin, vancomycin, and the

like), digitoxin, digoxin, drugs of abuse, theophylline, and warfarin, may also be determined.

Sensors may be available at pharmacies, hospitals, clinics, from doctors, and other sources of medical devices. Multiple sensors may be packaged together and
5 sold as a single unit; e.g., a package of about 25, about 50, or about 100 sensors, or any other suitable number. A kit may include one or more sensors, and additional components such as control solutions and/or lancing device and/or meter, etc.

Sensors may be used for an electrochemical assay, or, for a photometric test. Sensors are generally configured for use with an electrical meter, which may be
10 connectable to various electronics. A meter may be available at generally the same locations as the sensors, and sometimes may be packaged together with the sensors, e.g., as a kit.

Examples of suitable electronics connectable to the meter include a data processing terminal, such as a personal computer (PC), a portable computer such as
15 a laptop or a handheld device (e.g., personal digital assistants (PDAs)), and the like. The electronics are configured for data communication with the receiver via a wired or a wireless connection. Additionally, the electronics may further be connected to a data network (not shown) for storing, retrieving and updating data corresponding to the detected glucose level of the user.

20 The various devices connected to the meter may wirelessly communicate with a server device, e.g., using a common standard such as 802.11 or Bluetooth RF protocol, or an IrDA infrared protocol. The server device could be another portable device, such as a Personal Digital Assistant (PDA) or notebook computer, or a larger device such as a desktop computer, appliance, etc. In some
25 embodiments, the server device has a display, such as a liquid crystal display (LCD), as well as an input device, such as buttons, a keyboard, mouse or touch-screen. With such an arrangement, the user can control the meter indirectly by interacting with the user interface(s) of the server device, which in turn interacts with the meter across a wireless link.

30 The server device may also communicate with another device, such as for sending data from the meter and/or the service device to a data storage or computer. For example, the service device could send and/or receive instructions (e.g., an insulin pump protocol) from a health care provider computer. Examples of such communications include a PDA syncing data with a personal computer (PC), a

mobile phone communicating over a cellular network with a computer at the other end, or a household appliance communicating with a computer system at a physician's office.

5 A lancing device or other mechanism to obtain a sample of biological fluid, e.g., blood, from the patient or user may also be available at generally the same locations as the sensors and the meter, and sometimes may be packaged together with the sensor and/or meter, e.g., as a kit.

10 The sensors are particularly suited for inclusion in an integrated device, i.e., a device which has the sensor and a second element, such as a meter or a lancing device, in the device. The integrated device may be based on providing an electrochemical assay or a photometric assay. In some embodiments, sensors may be integrated with both a meter and a lancing device. Having multiple elements together in one device reduces the number of devices needed to obtain an analyte level and facilitates the sampling process. For example, embodiments may include
15 a housing that includes one or more of the sensor strips, a skin piercing element and a processor for determining the concentration of an analyte in a sample applied to the strip. A plurality of sensors may be retained in a cassette in the housing interior and, upon actuation by a user, a single sensor may be dispensed from the cassette so that at least a portion extends out of the housing for use.

20

Operation of the Sensor Strip

In use, a sample of biological fluid is provided into the sample chamber of the sensor, where the level of analyte is determined. The analysis may be based on providing an electrochemical assay or a photometric assay. In many embodiments,
25 it is the level of glucose in blood that is determined. Also in many embodiments, the source of the biological fluid is a drop of blood drawn from a patient, e.g., after piercing the patient's skin with a lancing device, which could be present in an integrated device, together with the sensor strip.

30 After receipt of the sample in the sensor, the analyte in the sample is, e.g., electrooxidized or electroreduced, at the working electrode and the level of current obtained at the counter electrode is correlated as analyte concentration. The sensor may be operated with or without applying a potential to the electrodes. In one embodiment, the electrochemical reaction occurs spontaneously and a potential need not be applied between the working electrode and the counter electrode. In another

embodiment, a potential is applied between the working electrode and the counter electrode.

The invention has been described with reference to various specific and preferred embodiments and techniques. However, it will be apparent to one of
5 ordinarily skill in the art that many variations and modifications may be made while remaining within the spirit and scope of the invention. It is understood that elements or features present on one embodiment described above could be used on other embodiments.

All patents and other references in this specification are indicative of the
10 level of ordinary skill in the art to which this invention pertains. All patents and other references are herein incorporated by reference to the same extent as if each individual patent or reference was specifically and individually incorporated by reference.

WHAT IS CLAIMED:

1. An analyte sensor for determining the concentration of an analyte in a sample, the sensor comprising a sample chamber having an inlet with a width and a projection extending from an edge of the sensor proximate the inlet, the projection having a width that is less than the inlet width.
2. The sensor of claim 1, wherein the width is no more than about 80% of the inlet width.
3. The sensor of claim 1, wherein the width is about 50% of the inlet width.
4. The sensor of any of claims 1-3, wherein the projection has a height of at least about 0.2 mm.
5. The sensor of any of claims 1-4, wherein the sensor comprises a first substrate and a second substrate, a spacer between the first substrate and the second substrate, together the first substrate, second substrate and spacer defining the inlet, and wherein the projection is defined by at least one of the first substrate and the second substrate.
6. The sensor of claim 5, wherein the projection extends from a side edge of the substrate.
7. The sensor of claim 5, wherein the projection extends from an end edge of the substrate.
8. The sensor of any of claims 5-7 wherein the projection is defined by the first substrate and the sensor further comprises a second projection defined by the second substrate.
9. The sensor of any of claims 1-8, wherein the sample chamber has a volume of no more than about 1 microliter.

10. An analyte sensor for determining the concentration of an analyte in a sample, the sensor comprising:
 - a first substrate, a second substrate, and a spacer layer therebetween;
 - a sample chamber defined between the first substrate and the second substrate bounded by the spacer layer, the sample chamber having at least one inlet; and
 - a protrusion extending from the first substrate at the inlet.
11. The sensor of claim 10 further comprising a second protrusion extending from the second substrate at the inlet.
12. The sensor of any of claims 10-11 further comprising a second inlet to the sample chamber and a third protrusion extending from the first substrate at the second inlet.
13. The sensor of claim 12 further comprising a fourth protrusion extending from the second substrate at the second inlet.
14. An analyte sensor for determining the concentration of an analyte in a sample, the sensor comprising:
 - a first substrate and a second substrate;
 - a first side edge, a second side edge and an end edge;
 - a sample chamber defined between the first substrate and the second substrate, the sample chamber extending from the first side edge to the second side edge;
 - a first aperture and a second aperture between the first substrate and the second substrate at the first side edge and the second side edge, respectively; and
 - at least one protrusion extending from either the first side edge or the second side edge, proximate the apertures.
15. The sensor of claim 14 comprising a first protrusion extending from the first side edge and a second protrusion extending from the second side edge.

16. The sensor of claim 15, further comprising a third protrusion extending from the first side edge and a fourth protrusion extending from the second side edge, proximate the apertures.
17. The sensor of any of claims 14-16, wherein the width of each of the protrusions is less than the width of the proximate aperture.
18. The sensor of any of claims 14-16, wherein the width of each of the protrusions is no more than about 80% of the width of the proximate aperture.
19. The sensor of any of claims 14-18, wherein the protrusions have a height of at least about 0.2 mm.
20. The sensor of any of claim 14-19, wherein the protrusions are triangles extending from the substrates.
21. A method of analyzing an analyte concentration in a sample comprising:
contacting a sample with a sensor;
transferring the sample into a sample chamber through an inlet bounded by at least one protrusion that has a width less than a width of the inlet; and
determining the concentration of analyte in the sample.
22. The method of claim 21, wherein transferring comprises transferring the sample into the sample chamber through an inlet bounded by two protrusions that have a width less than the width of the inlet.
23. A method of analyzing an analyte concentration in a sample comprising:
contacting a sample with a sensor having a first substrate, a second substrate and a spacer layer therebetween and at least one protrusion extending from one of the substrates;
transferring the sample into a sample chamber through an inlet bounded by the substrates and the at least one protrusion; and
determining the concentration of analyte in the sample.

24. The method of claim 23, wherein transferring comprises transferring the sample into the sample chamber through an inlet bounded by two protrusions.

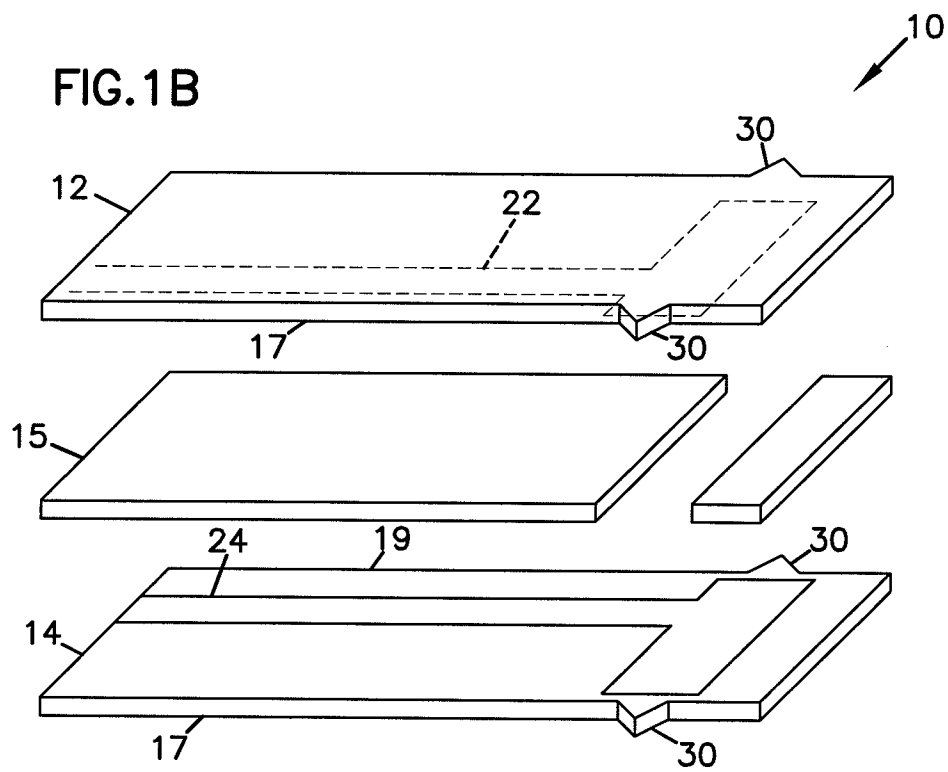
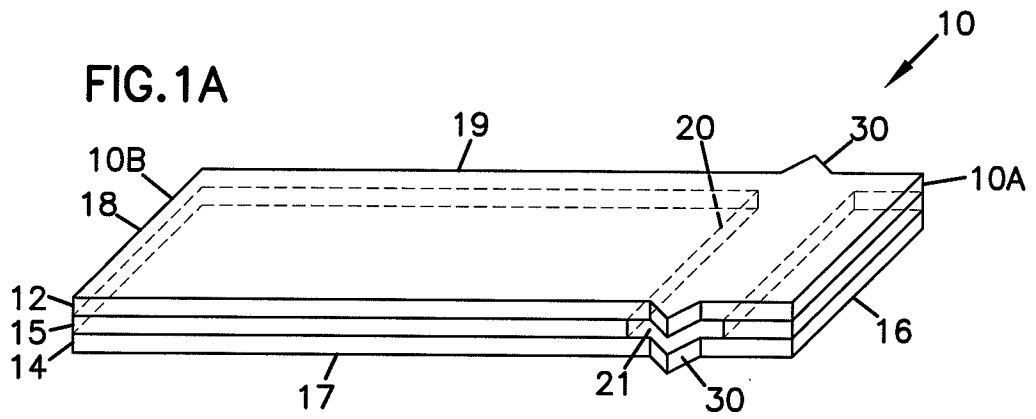

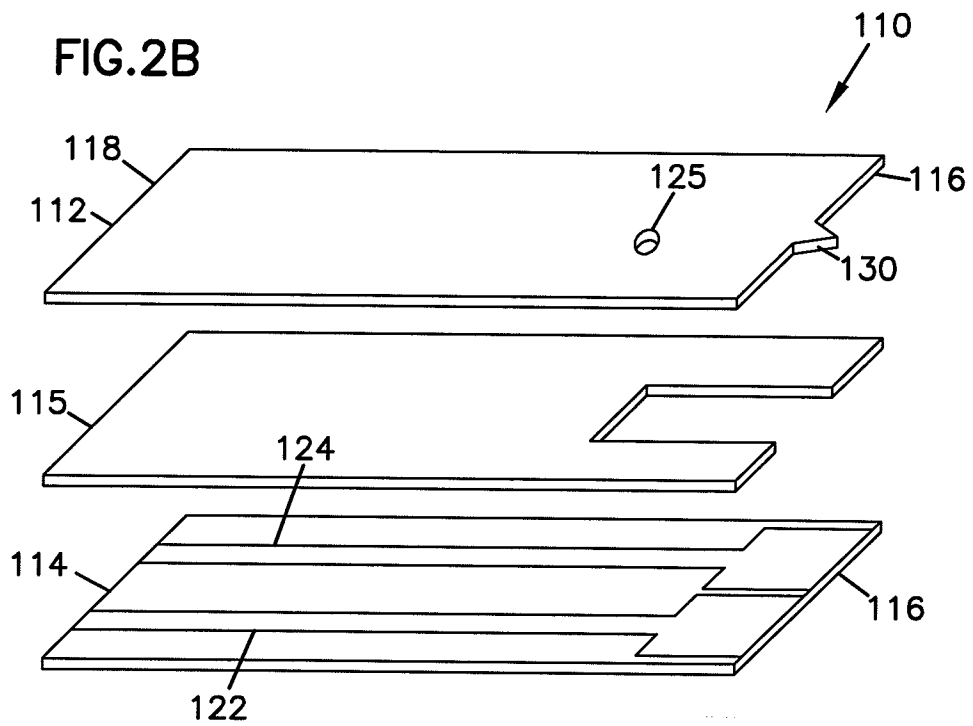
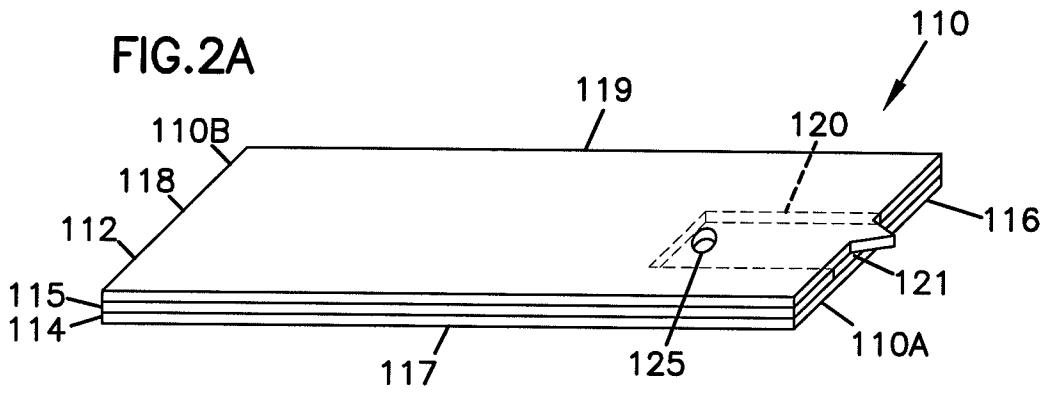

FIG.3A

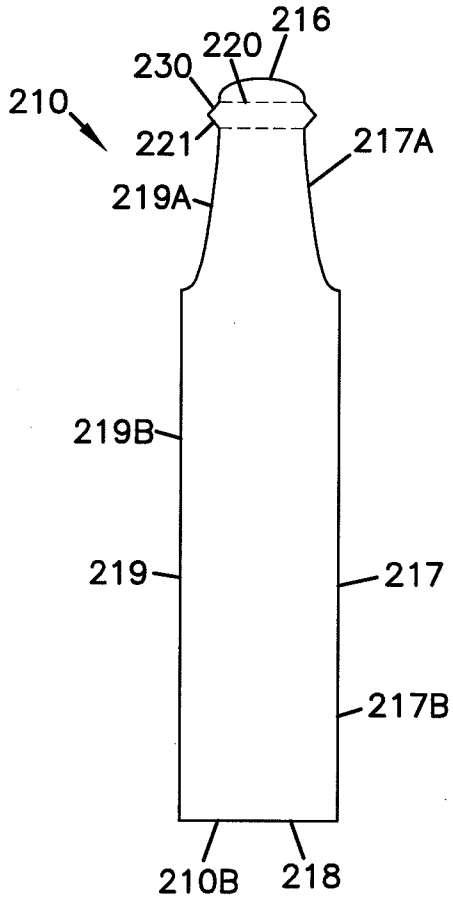

FIG.3B

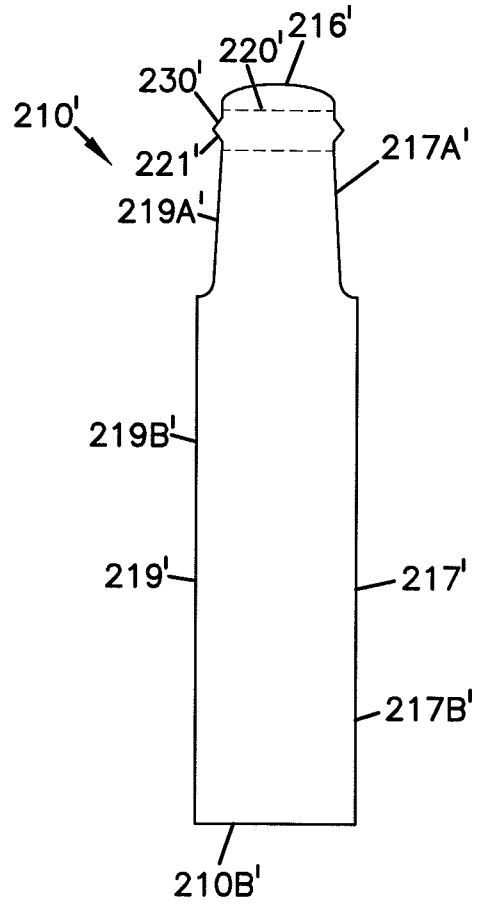
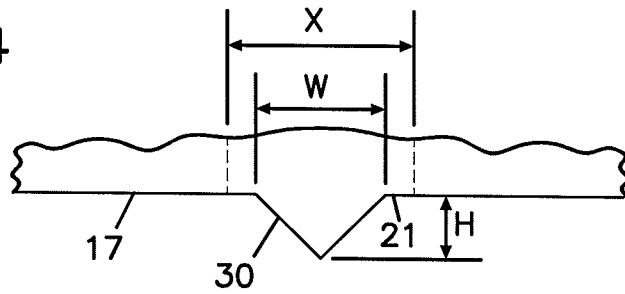

FIG.4



INTERNATIONAL SEARCH REPORT

International application No
PCT/US2007/086575

A. CLASSIFICATION OF SUBJECT MATTER
INV. B01L3/00 G01N33/487

According to International Patent Classification (IPC) or to both national classification and IPC

B. FIELDS SEARCHED

Minimum documentation searched (classification system followed by classification symbols)

B01L G01N

Documentation searched other than minimum documentation to the extent that such documents are included in the fields searched

Electronic data base consulted during the international search (name of data base and, where practical, search terms used)

EPO-Internal

C. DOCUMENTS CONSIDERED TO BE RELEVANT

Category*	Citation of document, with indication, where appropriate, of the relevant passages	Relevant to claim No.
X	US 2006/228263 A1 (BERNDTSSON INGEMAR [SE] ET AL) 12 October 2006 (2006-10-12) paragraphs [0003] - [0011], [0017] - [0021], [0025] paragraphs [0045], [0071]; claim 3; figure 2	1-24
X	WO 2005/043133 A (BAYER HEALTHCARE LLC [US]; BRENNEMAN ALLEN J [US]) 12 May 2005 (2005-05-12) page 3, line 25 - page 4, line 2; figure 1	1-11, 21-24
X	US 2003/086073 A1 (BRAIG JAMES R [US] ET AL) 8 May 2003 (2003-05-08) paragraph [0212]; figure 29 paragraphs [0179] - [0181], [0195], [0196]	1-7,9, 10,21-23
	----- -/--	

Further documents are listed in the continuation of Box C.

See patent family annex.

* Special categories of cited documents:

- *A* document defining the general state of the art which is not considered to be of particular relevance
- *E* earlier document but published on or after the international filing date
- *L* document which may throw doubts on priority claim(s) or which is cited to establish the publication date of another citation or other special reason (as specified)
- *O* document referring to an oral disclosure, use, exhibition or other means
- *P* document published prior to the international filing date but later than the priority date claimed

- *T* later document published after the international filing date or priority date and not in conflict with the application but cited to understand the principle or theory underlying the invention
- *X* document of particular relevance; the claimed invention cannot be considered novel or cannot be considered to involve an inventive step when the document is taken alone
- *Y* document of particular relevance; the claimed invention cannot be considered to involve an inventive step when the document is combined with one or more other such documents, such combination being obvious to a person skilled in the art.
- *Z* document member of the same patent family

Date of the actual completion of the international search

22 May 2008

Date of mailing of the international search report

02/06/2008

Name and mailing address of the ISA/

European Patent Office, P.B. 5818 Patentlaan 2
NL - 2280 HV Rijswijk
Tel. (+31-70) 340-2040, Tx. 31 651 epo nl,
Fax: (+31-70) 340-3016

Authorized officer

Tiede, Ralph

INTERNATIONAL SEARCH REPORT

International application No
PCT/US2007/086575

C(Continuation). DOCUMENTS CONSIDERED TO BE RELEVANT		
Category	Citation of document, with indication, where appropriate, of the relevant passages	Relevant to claim No.
A	EP 1 437 589 A (HMD BIOMEDICAL INC [TW]) 14 July 2004 (2004-07-14) paragraphs [0017] - [0026]; figures 1-3	5,12-20
A	WO 01/73395 A (USF FILTRATION & SEPARATIONS [US]) 4 October 2001 (2001-10-04) pages 1-3	5,12-20

INTERNATIONAL SEARCH REPORT

Information on patent family members

International application No

PCT/US2007/086575

Patent document cited in search report	Publication date	Patent family member(s)	Publication date
US 2006228263 A1	12-10-2006	CA 2600999 A1	12-10-2006
		CN 101160520 A	09-04-2008
		EP 1866620 A1	19-12-2007
		SE 528638 C2	09-01-2007
		SE 0500784 A	09-10-2006
		WO 2006107262 A1	12-10-2006
WO 2005043133 A	12-05-2005	AU 2004285233 A1	12-05-2005
		CA 2539493 A1	12-05-2005
		CN 1875260 A	06-12-2006
		EP 1685385 A1	02-08-2006
		JP 2007510163 T	19-04-2007
		KR 20060085678 A	27-07-2006
US 2003086073 A1	08-05-2003	US 2003090649 A1	15-05-2003
		US 2003086074 A1	08-05-2003
		US 2003086075 A1	08-05-2003
EP 1437589 A	14-07-2004	CA 2455044 A1	13-07-2004
		CN 1527049 A	08-09-2004
		TW 276797 B	21-03-2007
		US 2004134779 A1	15-07-2004
WO 0173395 A	04-10-2001	AT 345166 T	15-12-2006
		AU 4946801 A	08-10-2001
		AU 2001249468 B2	29-09-2005
		CA 2403660 A1	04-10-2001
		CN 1431933 A	23-07-2003
		CZ 20023516 A3	12-11-2003
		DE 60124514 T2	06-09-2007
		EP 1268064 A2	02-01-2003
		HK 1052478 A1	20-04-2007
		JP 2003529071 T	30-09-2003
		MX PA02009562 A	30-07-2004
		PL 359493 A1	23-08-2004
		SG 129300 A1	26-02-2007
		TW 496952 B	01-08-2002
		US 2005126915 A1	16-06-2005
		US 2003167862 A1	11-09-2003
		US 2004040394 A1	04-03-2004
US 6571651 B1	03-06-2003		