

(19)
(12)

(KR)
(Y1)

(51) 。 Int. Cl.7
E04G 17/06

(45)
(11)
(24)

2004 11 12
20-0367608
2004 11 02

(21) 20-2004-0024753
(22) 2004 08 30

(73) 990-165

(72) 990-165

(74)

:

(54)

(7) , (7) (2) (2) '□' (7)
(6) (7) (7) (701) (2) (601)가 (603) (9,9') , (6) , (7)
(3) , (6) (6) (6) (6) (7) (6) (201)
, (100)가 , (6) (6) (202)가 (200)
(4) (200) (4) (8) .

1

1

2,3

4 ()

5 ()

6

< >

1),	(1),	(2),	(2a),	(3),	(4,4'),	(4a),	(5),	(6),	(7),	(7-
(203,204),	(8),	(9,9'),	(100),	(101),	(101),	(200,200'),	(201),	(201),	(202),	(202),
(604),	(205),	(205),	(301),	(302),	(302),	(303),	(601),	(602),	(603),	(603),
	(605),	(605),	(606),	(701),	(701),	(702),	(703,703')	(703,703')		

가 ,

가 가 가 가

326598 가 , 가

가 가 가

가

(9,9') , 'ㄷ' (7) (7) (7) (2) (2)
 (6) (6) , (6) (7) (701) (2) (601)가 (603)
 (201) (200) , (3) (7) (6) (601) (7)
 (202)가 (200) , (4) (200) (100)가 (6) (6)
 (7), (6), (3), (200)
 (2) 'ㄷ' (2)
 , 가 (703,703') , (2) 가 (9,9')
 (3)가 (701) (702) , (6) (7)
 (6) (604) (601) (605) , (6)
 (200) (200) (605)
 0) (603) 가 , (200) (603) (20)
 (200) (605) 가 (6) (605)
 (3) (7) 가
 (200) (202) (6) , (6) , (201) (602)
 (200) (200) (202) (6) (605) (101) (200)
 (100)가
 (9,9') (201) (200) (6) , (6) (2) (603)
 (7) (7) (200) (2) (601)가 (7-1) (2a)
 (7-1) (2)
 (202) 4 (1) (100) () (101) (200)
 (200) (200) (200) (100) (101)
 (4)가 (2) (2a) (8)가 (2a)
 (200)
 (4) (6) (200) (2) (7-1) (3) (6)
 (604) (7) (2a) (1) (1,2) (702) , (604) (3)
) (7) (701) (702) , (604) (6) (3)
 (606) (7)

(3) 가 , (302) , (6) 가 (301)
(302) , (3) (3)
(200) 6 , (4')

가

가 , 가

'ㄷ' , 가

가 , 가

가 (7) 가

(57)

1.

(7) , (7) , (2) (2) 'ㄷ'
(7) (7) (2) 2 (9,9') , (7) (6)
(7) (701) (601)가 (601) (603) (6) , (6)
(3) (7) (6) (6) (601) (7) (6) (201) ,
(6) (100)가 , (6) (6) (202)가 (200) ,
(200) (4) (8) (4)

2.

1 , (7) 'ㄷ'
(702) , , (701) , (701)
(703,70
3')

3.

1 , (6) (601) , (601)
(602) , 120 (601) 가 (603) , (601)
(604) , (604)
(605) , (601) (604) , (606) (200) (604)

4.

1 , (200) (6) (602) (201) ,
 100)가 (202) , (202)
 (203,204) , (203,204) (205)

5.
 1 , (200) (6) (602) (201) ,
 100)가 (202) , (202)
 (4')

6.
 1 (205) (5) (4) (8) (4a) (203,204) (200)

7.
 1 (301) , (303)가 (3) 가 (302) , (302) (6) 가

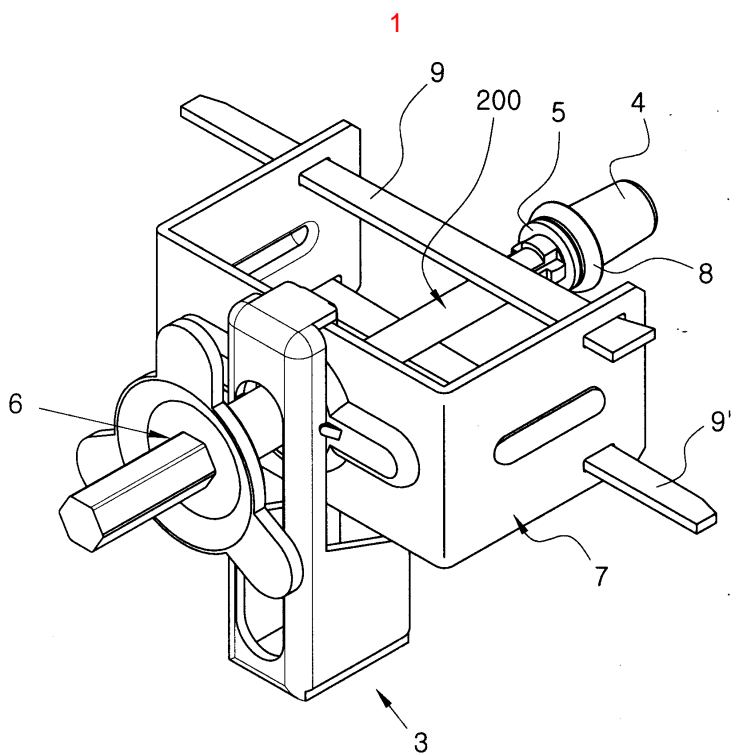

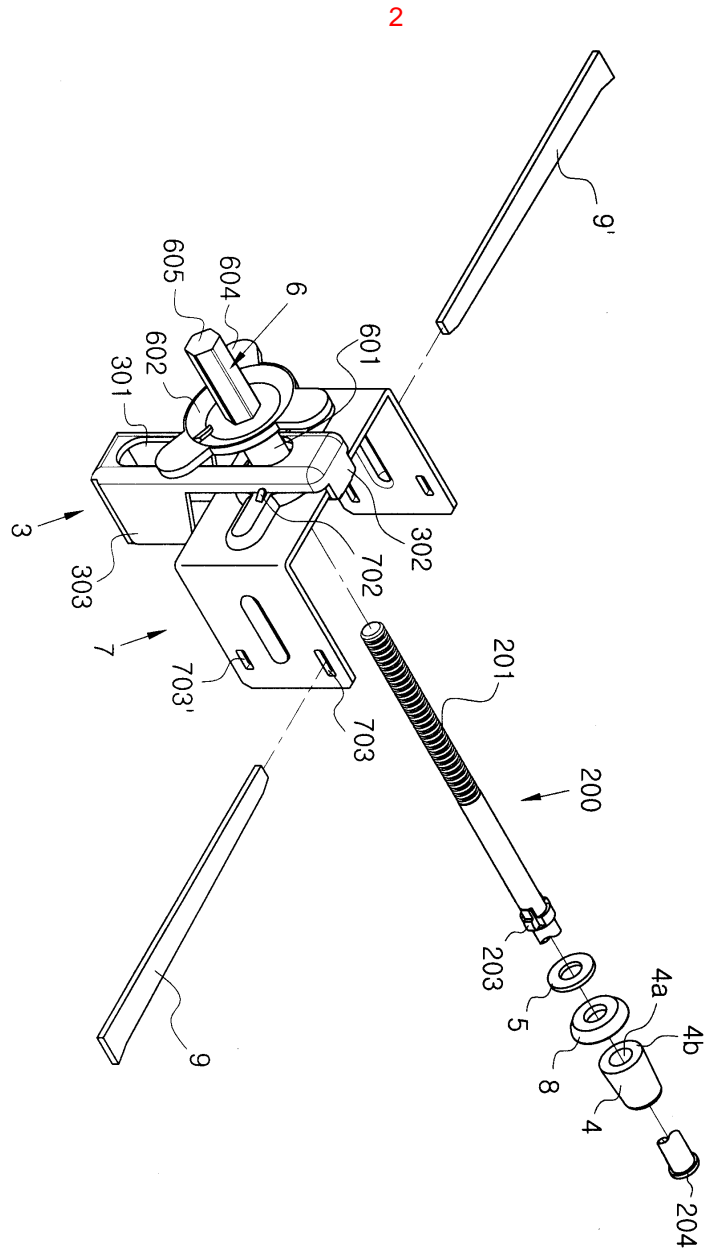

3

