

(12) INTERNATIONAL APPLICATION PUBLISHED UNDER THE PATENT COOPERATION TREATY (PCT)

(19) World Intellectual Property Organization
International Bureau



(43) International Publication Date
28 March 2002 (28.03.2002)

PCT

(10) International Publication Number
WO 02/25846 A2

- (51) International Patent Classification⁷: **H04B 17/00**, 1/40
- (21) International Application Number: PCT/EP01/10312
- (22) International Filing Date:
6 September 2001 (06.09.2001)
- (25) Filing Language: English
- (26) Publication Language: English
- (30) Priority Data:
09/665,925 20 September 2000 (20.09.2000) US
- (71) Applicant: **KONINKLIJKE PHILIPS ELECTRONICS N.V.** [NL/NL]; Groenewoudseweg 1, NL-5621 BA Eindhoven (NL).
- (72) Inventor: **MOHINDRA, Rishi**; Prof. Holstlaan 6, NL-5656 AA Eindhoven (NL).
- (74) Agent: **VOLMER, Georg**; INTERNATIONAAL OCTROOIBUREAU B.V., Prof. Holstlaan 6, NL-5656 AA Eindhoven (NL).
- (81) Designated States (*national*): CN, JP, KR.
- (84) Designated States (*regional*): European patent (AT, BE, CH, CY, DE, DK, ES, FI, FR, GB, GR, IE, IT, LU, MC, NL, PT, SE, TR).
- Published:**
— without international search report and to be republished upon receipt of that report
— entirely in electronic form (except for this front page) and available upon request from the International Bureau
- For two-letter codes and other abbreviations, refer to the "Guidance Notes on Codes and Abbreviations" appearing at the beginning of each regular issue of the PCT Gazette.*



WO 02/25846 A2

(54) Title: CALIBRATION OF A TRANSMIT BRANCH AND/OR A RECEIVE BRANCH OF A QUADRATURE TRANSMITTER AND/OR TRANSCEIVER

(57) Abstract: A method of calibrating a transmit branch of a transmitter is provided. A low frequency component in a high frequency output signal of the transmit branch is measured. The low frequency component is present when the transmit branch is uncalibrated. From the measured low frequency component, a first compensation signal is derived. The first compensation signal is injected into an in-phase branch of the transmit branch. A second compensation signal is derived and injected into a quadrature branch of the transmit branch. The first and second compensation signals are swept and adapted on the basis of the measured low frequency component. From the sweeping, minimum values of the measured low frequency component are obtained. Thereafter, the first and second compensation signals are successively set at the minimum values. In addition to calibrating the transmit branch, in case of a transceiver, a receive branch may be calibrated. To calibrate the receive branch, the calibrated transmitter is coupled to the receive branch. Thereafter, the receive branch is calibrated through sweeping and setting of receiver branch parameters.

Calibration of a transmit branch and/or a receive branch of a quadrature transmitter and/or transceiver

The present invention relates to a transmitter or transceiver, more particularly to calibration of a transmit branch of such a transmitter or transceiver. In case of a transceiver, in addition to calibration of the transmit branch, a receive branch may be calibrated as well. Such a transmitter or transceiver operates in the so-called 2.4 GHz ISM
5 band, for instance, or can be any other suitable transmitter or transceiver.

The US Patent No. 5,793,817 discloses DC offset reduction in a transmitter. The transmitter has up-converters and an rf power amplifier through which a transmitter
10 output signal is provided to an antenna. The transmitter has a feedback loop. The feedback loop derives a portion of the output signal, and divides the derived signal into phase related feedback paths. Each of the feedback path has frequency-down converters. The DC offset is measured at inputs of the up-converters when the feedback around a linearization loop is reduced to zero without altering the dc offsets produced at the outputs of the frequency
15 down-converters. Subtractors subtract the measured DC offsets from feedback loop error signals. Such a DC nulling removes the effects of carrier feedthrough of the down-conversion mixers, thereby improving the resulting carrier feedthrough of the transmitter.

20 It is an object of the invention to provide a quadrature transmitter or transceiver with full compensation of carrier leakage, and of gain and phase imbalances.

It is another object, in case of a transceiver, after calibration of the transmit branch, to also calibrate the gain of a receive branch of the transceiver.

It is another object of the invention to perform such a calibration at different
25 power settings of the transmitter when respectively sweeping and setting the transmitter.

In accordance with the invention, a method of calibrating a transmit branch of a transmitter is provided, the method comprising:

measuring a low frequency component in a high frequency output signal of said transmit branch, said low frequency component being present when said transmit branch is uncalibrated;

5 from said measured low frequency component, deriving a first compensation signal and injecting said first compensation signal into an in-phase branch of said transmit branch, and deriving a second compensation signal and injecting said second compensation signal into a quadrature branch of said transmit branch;

sweeping said first and second compensation signals and adapting said first and second derived compensation signals on the basis of said low frequency component;

10 from said sweeping, obtaining minimum values of said measured low frequency component; and

successively setting said first and second compensation signals at said minimum values.

15 Preferably, said compensation signals are injected after transmit filters in respective in-phase and quadrature branches of the transmit branch so that optimal carrier leakage compensation is achieved.

20 Preferably, different relative signal strengths of the high frequency output signal, a local oscillator signal, and sideband signals in a still uncalibrated transmitter are optimally taken into account when calibrating the transmitter. Such relative signal strength may vary depending on the silicon process used to manufacture the transmitter. For strong sideband signals with respect to the carrier leakage signal carrier leakage compensation is done at full output power, and, thereafter, gain and phase error compensation is done at an output power level substantially lower than an output level of expected maximum carrier leakage. For weak sideband signals with respect to a carrier leakage signal, carrier leakage
25 compensation is done at an output power level substantially lower than an output level of expected maximum carrier leakage, and, thereafter, gain and phase error compensation is done at full power.

30 In case of a transceiver that, in addition to the transmit branch, comprises a receive branch, preferably the method also comprises calibrating of the receive branch, by sweeping a gain setting in said receive branch while measuring an error signal, by obtaining a still further minimum value of said error signal during said sweeping of said gain in said receive branch, and by setting said gain in said receive branch to a value corresponding to said still further minimum value. Herewith it is achieved that the transceiver is fully calibrated after sweeping and setting.

Fig. 1 is a block diagram of a transceiver according to the present invention.

Fig. 2 is a first embodiment of a power detector for use in a transceiver
5 according to the present invention.

Fig. 3 is a second embodiment of a power detector for use in a transceiver
according to the present invention.

Fig. 4 is a third embodiment of a power detector for use in a transceiver
according to the present invention.

10 Fig. 5 illustrates local oscillator leakage calibration according to the invention.

Fig. 6 illustrates local oscillator leakage.

Figs. 7A-7D show sweeping of transmitter parameters for transmitter
calibration.

Figs. 8A-8B further illustrate transmitter calibration.

15 Figs. 9A-9C illustrate receiver calibration.

Throughout the Figs. the same reference numerals are used for the same
features.

20 Fig. 1 is a block diagram of a transceiver 1 according to the present invention.
In the example given, the transceiver 1 operates in the so-called 2.4 GHz ISM (Industrial,
Scientific and Medical) band, and is a so-called zero-IF transceiver that receives and
transmits at the same frequency so that only a single tuned oscillator is needed. The
transceiver 1 comprises a receive branch 2 and a transmit branch 3. The receive branch 2
25 comprises a low noise amplifier (LNA) 4 that is coupled to an antenna 5 via a filter 6 and a
transmit/receive switch 7. The LNA 4 is coupled to a pair of quadrature mixers 8 and 9 in
respective in-phase and quadrature receive branches. Through an AC-coupler 10, the mixer 8
is AC-coupled to a low pass filter 11. Through an AC-coupler 12, the mixer 9 is coupled to a
low pass filter 13. According to the invention, the in-phase receive branch has a adjustable
30 amplifier 14 to adjust the gain of the receive branch 2, and an injector 15 to inject a DC-
voltage in order to compensate for DC-offsets, and the quadrature receive branch has an
injector 16 to inject a DC-voltage to compensate for DC-offsets. The injectors 15 and 16 may
be adders. Instead of the adjustable amplifier 14 in the in-phase receive branch, an adjustable
amplifier may be included in the quadrature receive branch. Alternatively, both the in-phase

and quadrature transmit branches, the transmit branch 3 of the transceiver 1 comprises transmit filters 20 and 21. According to the invention, after the transmit filters 20 and 21, the in-phase and quadrature transmit branches comprise respective injectors 22 and 23 to inject DC-voltages for calibrating the transmit branch 2, and further an adjustable amplifier 24 in the quadrature transmit branch. Instead of the adjustable amplifier 24 in the quadrature transmit branch, an adjustable amplifier may be included in the in-phase receive branch. Alternatively, both the in-phase and quadrature transmit branches may comprise adjustable amplifiers. Through respective up-converters or mixers 25 and 26 and an adder 27, the injectors 22 and 23 are coupled to transmit power amplifiers 28 and 29. The transmit power amplifier 29 is coupled to the transmit/receive switch 7.

The transceiver 1 further comprises means 40 for measuring a low frequency component in a high frequency output signal of the transmit branch 3. In the example given, the means 40 comprises a power detector 41, a high pass filter 42, and an AC-voltage detector 43. When the transmitter branch 3 is fully calibrated, the power detector 41 provides a constant DC-signal so that the AC-voltage detector 43 does not produce an output signal. When the transmitter branch 3 is still uncalibrated, the power detector 41 provides a varying DC-signal, i.e. a low frequency component, so that the AC-voltage detector 43 produces an output signal.

The transceiver 1 further comprises a voltage controlled oscillator 50 that is controlled by a phase locked loop (PLL) 51. The VCO 50 provides a local oscillator signal to the respective mixers 8 and 25 in the in-phase receive and transmit branches, and, through an adjustable phase shifter 52, a phase shifted local oscillator signal to the respective mixers 9 and 26 in the quadrature receive and transmit branches. The adjustable phase shifter 52 is adjustable around a ninety degrees nominal phase shift.

The transceiver 1 further comprises a controller 60. The controller 60 comprises a processor 61, a non-volatile memory 62 for storing non-volatile data such as program and calibration data, and RAM 63 for storing volatile data. The controller 60 further comprises analog-to-digital converters (ADC) 64, 65, and 66 for sampling received and down-converted signals provided by the injectors 15 and 16, and for sampling an output signal provided by the AC-voltage detector 43, respectively. The controller 60 further comprises digital-to-analog converters (DAC) 67 and 68 for providing respective in-phase and quadrature transmit signals to the transmit filters 20 and 21, and digital-to-analog converters 69, 70, 71, 72, 73, 74, and 75 for respectively providing adjustment or calibration signals to the injectors 15 and 16, the amplifier 14, the injectors 22 and 23, the amplifier 24,

and the phase shifter 52. In addition thereto, the processor 61 controls a switch 80 that couples an output of the power amplifier 29, via an attenuator 81, to an output of the LNA 4.

Fig. 2 is a first embodiment of the power detector 41. In this embodiment, the power detector 41 comprises an AM-demodulator formed by a diode 90, a resistor 91 and a capacitor 92. The AM-demodulator provides an output voltage that is proportional to the square root of the RF output power provided by the power amplifier 28.

Fig. 3 is a second embodiment of the power detector 41. In this embodiment, the power detector 41 comprises a micro-strip coupler 93 and a Schottky diode 94. In this embodiment, the power detector provides an output voltage that is proportional to the RF output power provided by the power amplifier 28.

Fig. 4 is a third embodiment of the power detector 41. In this embodiment, the power detector 41 comprises a mixer 95, a resistor 96 and a capacitor 97. In this embodiment, the power detector provides an output voltage that is proportional to the RF output power provided by the power amplifier 28.

Fig. 5 illustrates local oscillator leakage calibration according to the invention. In a perfectly calibrated transmit branch 3, calibrated for carrier leakage, gain and phase, a four phase quadrature signal constellation, as indicated by four dots, is a perfect circle 100 as indicated by the dashed signal, i.e. the amplifier 28 provides constant RF power as indicated by constant radius r . Due to carrier leakage from the VCO 50 through the mixers 25 and 26, in an uncalibrated transmit branch, the signal constellation, for calibrated gain and phase, shifts as indicated by a solid circle 101 with a new center. The shifted circle 101 results in the transmit branch having different DC-components in the in-phase and quadrature transmit branches, V_{DC_I} and V_{DC_Q} . Because radius r is then no longer constant, the RF power at the amplifier 28 significantly changes in proportionality with the square of radius r . Carrier leakage is compensated by injecting proper calibration voltages in the injectors 22 and 23. In case of still uncalibrated gain and phase in the transmit branch 3, the circle adopts the form of an ellipse so that also gain and phase calibration is needed.

Fig. 6 illustrates local oscillator leakage in the frequency domain. Shown is a spectrum of f_{RF} and carrier leakage signal f_{LO} , for a single tone transmitted signal.

Figs. 7A-7D show sweeping of transmitter parameters for transmitter calibration. In Figs. 7A and 7B, respective sweeping of signals V_1 and V_2 to the injectors 22 and 23 is shown. The DACs 72 and 73 are respectively set to $V_{1,opt}$ and $V_{2,opt}$. Herewith carrier leakage is compensated for. In order to achieve better calibration, sweeping and setting of V_1 and V_2 is repeated at least once. In Figs. 7C and 7D, respective sweeping of

signals $\Delta G1$ and $\Delta\theta$ to the amplifier 24 and the phase shifter 52 is shown. The DACs 74 and 75 are respectively set to $\Delta G1, \text{opt}$ and $\Delta\theta, \text{opt}$. Herewith gain and phase imbalances in the transmit branch 3 are compensated for.

Figs. 8A-8B further illustrate transmitter calibration with still uncalibrated gain and phase imbalances. Here, as shown in Fig. 8A, the sideband signal power P_{SB} due to uncalibrated gain and phase imbalances is much weaker than the carrier leakage signal power P_{LO} , both signals being shown with respect to P_{RF} . Then, it is advantageous to start calibration at a signal power at a level below full power equal to the worst case expected LO-leakage that is IC-process dependent. As indicated in Fig. 8A with an arrow then first low leakage is compensated for. Then, as illustrated in Fig. 8B, full power is applied to the transmit branch 3, resulting in signal powers P'_{SB} , P'_{LO} and P'_{RF} . Because P_{LO} is independent of the power of the transmitted signal P'_{LO} , the reduced carrier leakage signal does not change when increasing transmit power. At full power, gain and phase imbalances are calibrated resulting in a reduced side band power. For better results, calibration is repeated at least once.

For a much stronger transmitted signal as compared to the expected carrier leakage signal, it is likely that in an uncalibrated transmit branch also the side band power is much stronger than the carrier leakage signal. Then, first gain and phase imbalances are compensated for at full transmit power, and LO leakage is compensated for thereafter at reduced transmit power. For better results, at again full transmit power, gain and phase calibration is repeated.

Figs. 9A-9C illustrate receiver calibration, receiver calibration being done after transmitter calibration. In case of an AC-coupled receiver, only gain errors are calibrated in the receiver branch 2. In case of a DC-coupled receiver, in addition to gain error calibration, also DC-offset errors may be calibrated. After calibration of the transmitter, the signal constellation for transmitted signals is optimal. With this optimal signal constellation, the processor 61 closes the switch 80 and performs receiver calibration. Fig. 9A shows an error voltage $V_{\text{error}} = | \text{peak-peak}(V_{\text{I}_R}) - \text{peak-peak}(V_{\text{I}_Q}) |$, V_{I_R} and V_{I_Q} being shown in Fig. 1. Fig. 9B shows $V_{\text{error}} = \text{average}(V_{\text{I}_R})$. Fig. 9B shows $V_{\text{error}} = \text{average}(V_{\text{I}_Q})$. As shown in Fig. 9A, the DAC 72 sweeps the gain signal $\Delta G2$ and sets an optimum gain at $\Delta G2, \text{opt}$. Gain sweeping can be done starting from a high gain, a low gain, or a nominal gain. As shown in Figs. 9B and 9C, DC-offsets can accordingly be set by the DACs 69 and 70, at $V_{3,\text{opt}}$ and $V_{4,\text{opt}}$. In one scenario, V_3 and V_4 are set at some expected maximum DC-offset below full power reception, and, thereafter, at full power reception, the calibrated gain. For more accuracy, calibration may be repeated at least once.

In view of the foregoing it will be evident to a person skilled in the art that various modifications may be made within the spirit and the scope of the invention as hereinafter defined by the appended claims and that the invention is thus not limited to the examples provided. The word "comprising" does not exclude the presence of other elements
5 or steps than those listed in a claim.

CLAIMS:

1. A method of calibrating a transmit branch (3) of a transmitter, said method comprising:
 - measuring a low frequency component in a high frequency output signal (V_0) of said transmit branch (3), said low frequency component being present when said transmit
 - 5 branch (3) is uncalibrated;
 - from said measured low frequency component, deriving a first compensation signal (V_1) and injecting (22) said first compensation signal (V_1) into an in-phase branch of said transmit branch, and deriving a second compensation signal (V_2) and injecting (23) said
 - 10 second compensation signal (V_2) into a quadrature branch of said transmit branch;
 - sweeping said first and second compensation signals (V_1, V_2) and adapting
 - said first and second derived compensation signals on the basis of said low frequency
 - component;
 - from said sweeping, obtaining minimum values ($V_{1,opt}, V_{2,opt}$) of said measured
 - low frequency component; and
 - 15 successively setting said first and second compensation signals at said
 - minimum values ($V_{1,opt}, V_{2,opt}$).
2. A method as claimed in Claim 1, therein repeating said sweeping at least once.
- 20 3. A method as claimed in Claim 1, therein injecting said compensation signals after respective transmit filters (20, 21) in said in-phase and quadrature transmit branches, said set first and second compensation signals compensating for local oscillator carrier leakage in said transmitter.
- 25 4. A method as claimed in Claim 3, further comprising sweeping gain and phase settings ($\Delta G1, \Delta\theta$) in said transmit branch while measuring said low frequency component, obtaining further minimum values ($\Delta G1, opt; \Delta\theta, opt$) of said low frequency component during said sweeping of said gain and phase settings, and respectively setting said gain and phase settings to values corresponding to said further minimum values ($\Delta G1, opt; \Delta\theta, opt$).

5. A method as claimed in Claim 4, therein setting said gain and phase settings at a first transmit power of said transmitter, and repeating said local oscillator carrier leakage compensation at a second transmit power of said transmitter, said first transmit power
5 substantially differing from said second transmit power.
6. A method as claimed in Claim 5, therein repeating said gain and phase compensation at said first transmit power.
- 10 7. A method as claimed in Claim 1, further comprising calibrating a receive branch of a receiver (2), whereby said transmitter (3) and receiver (2) form a transceiver, said calibrating of said receive branch comprising sweeping a gain setting in said receive branch while measuring an error signal (V_{error}), obtaining a still further minimum value of said error signal during said sweeping of said gain in said receive branch, and setting said gain in said
15 receive branch to a value ($\Delta G2, \text{opt}$) corresponding to said still further minimum value.
8. A transmitter (3) comprising:
a transmit branch;
means for measuring a low frequency component in a high frequency output
20 signal (V_0) of said transmit branch, said low frequency component being present when said transmit branch is uncalibrated;
means for deriving, from said measured low frequency component, a first compensation signal (V_1) and for injecting (22) said first compensation signal (V_1) into an in-phase branch of said transmit branch, and means for deriving a second compensation signal
25 (V_2) and for injecting said second compensation signal (V_2) into a quadrature branch of said transmit branch;
means for sweeping said first and second compensation signals (V_1, V_2) and for adapting said first and second derived compensation signals on the basis of said low frequency component;
30 means for obtaining, from said sweeping, minimum values ($V_{1,\text{opt}}, V_{2,\text{opt}}$) of said measured low frequency component; and
means for successively setting said first and second compensation signals at said minimum values ($V_{1,\text{opt}}, V_{2,\text{opt}}$).

9. A transmitter (3) as claimed in Claim 8, further comprising respective transmit filters (20, 21) in said in-phase and quadrature transmit branches, and means for injecting (22, 23) said compensation signals after said respective transmit filters (20, 21), said set first and second compensation signals ($V_{1,opt}$, $V_{2,opt}$) compensating for local oscillator carrier
5 leakage in said transmitter (3).

10. A transmitter (3) as claimed in Claim 9, further comprising means for sweeping gain and phase settings in said transmit branch while measuring said low frequency component, means for obtaining further minimum values of said low frequency component
10 during said sweeping of said gain and phase settings, and means for respectively setting said gain and phase settings to values values ($\Delta G_{1, opt}$; $\Delta\theta, opt$) corresponding to said further minimum values.

11. A transmitter (3) as claimed Claim 10, said transmitter being configured to set
15 said gain and phase settings at a first transmit power of said transmitter, and to repeat said local oscillator carrier leakage compensation at a second transmit power of said transmitter, said first transmit power substantially differing from said second transmit power.

12. A transmitter (3) comprising:
20 a transmit branch;
a controller (60);
an output signal detector (40) for measuring a low frequency component in a high frequency output signal (V_0) of said transmit branch, said low frequency component being present when said transmit branch is uncalibrated;
25 said controller being configured to derive, from said measured low frequency component, a first compensation signal (V_1) and to inject (22) said first compensation signal (V_1) into an in-phase branch of said transmit branch, and to derive a second compensation signal (V_2) and to injecting (23) said second compensation signal (V_2) into a quadrature branch of said transmit branch;
30 said controller (60) further being configured to sweep said first and second compensation signals (V_1 , V_2) and to adapting said first and second derived compensation signals on the basis of said low frequency component, to obtain, from said sweeping, minimum values of said measured low frequency component, and to successively set said first and second compensation signals at said minimum values ($V_{1, opt}$, $V_{2, opt}$).

13. A transceiver (1) comprising:
a transmit branch (3);
means for measuring a low frequency component in a high frequency output
5 signal (V_0) of said transmit branch, said low frequency component being present when said
transmit branch is uncalibrated;
means for deriving, from said measured low frequency component, a first
compensation signal (V_1) and for injecting (22) said first compensation signal (V_1) into an in-
phase branch of said transmit branch, and means for deriving a second compensation signal
10 (V_2) and for injecting (23) said second compensation signal (V_2) into a quadrature branch of
said transmit branch;
means for sweeping said first and second compensation signals (V_1 , V_2) and
for adapting said first and second derived compensation signals on the basis of said low
frequency component;
15 means for obtaining, from said sweeping, minimum values of said measured
low frequency component; and
means for successively setting said first and second compensation signals at
said minimum values ($V_{1, opt}$, $V_{2, opt}$).
- 20 14. A transceiver as claimed in Claim 13, further comprising a receive branch (2),
for calibrating of said receive branch said transceiver comprising means for sweeping a gain
setting in said receive branch while measuring an error signal (V_{error}), means for obtaining a
further minimum value of error signal during said sweeping of said gain in said receive
branch, and means for setting said gain in said receive branch to a value ($\Delta G2, opt$)
25 corresponding to said further minimum value.

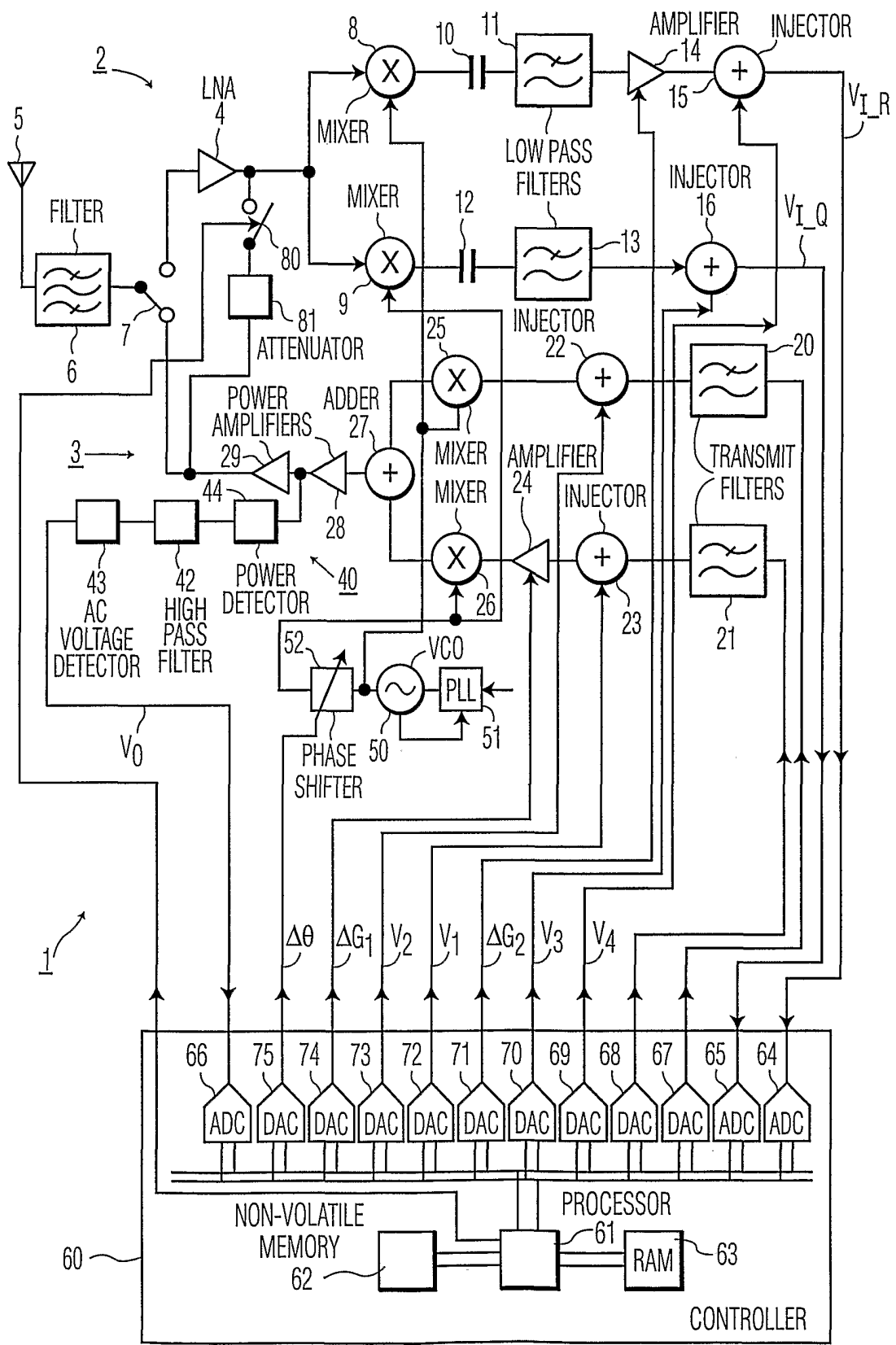

FIG. 1

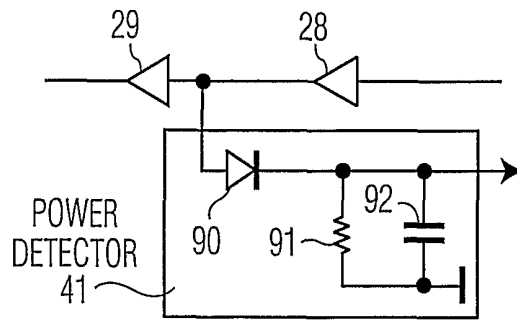

FIG. 2

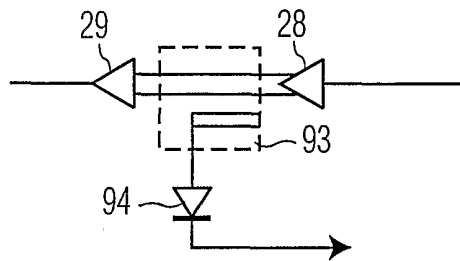

FIG. 3

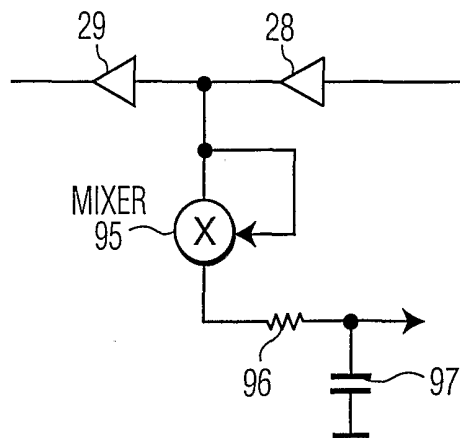

FIG. 4

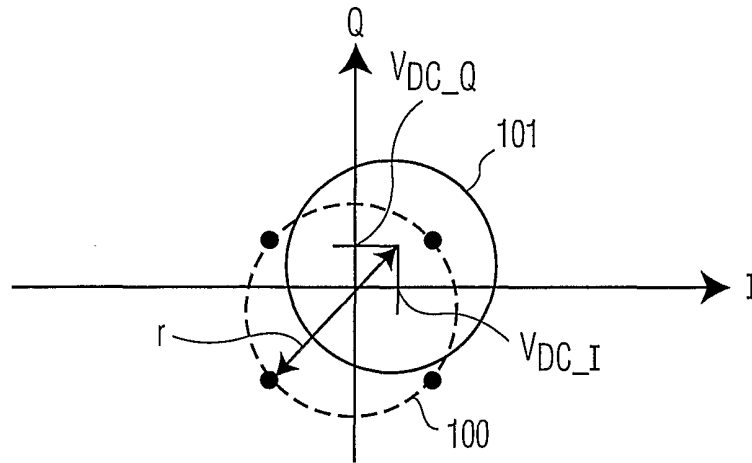

FIG. 5

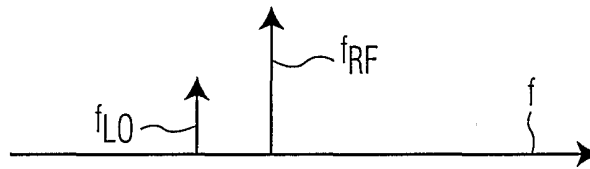

FIG. 6

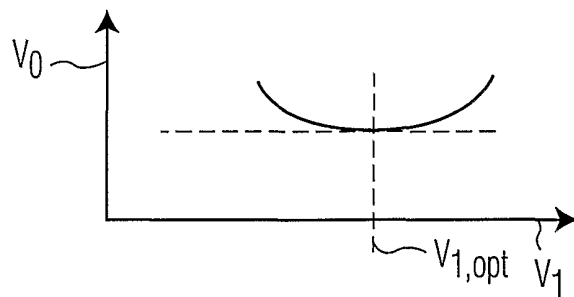

FIG. 7A

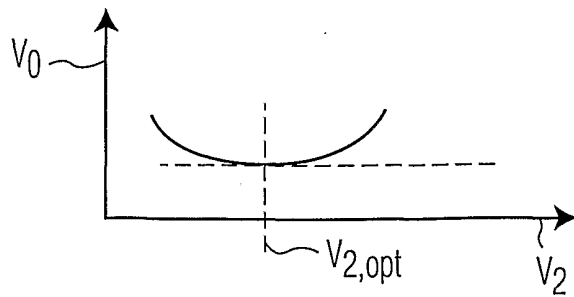

FIG. 7B

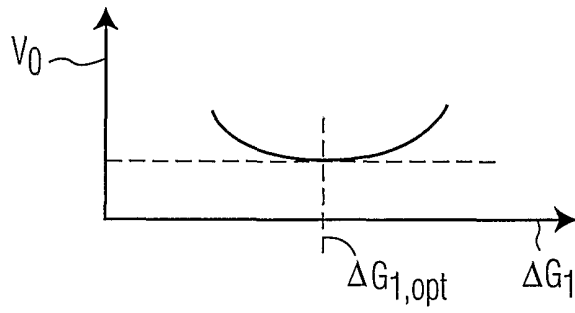

FIG. 7C

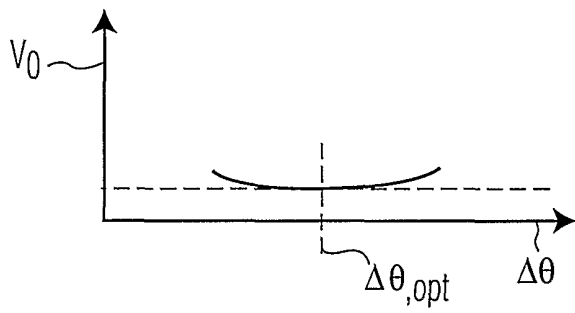

FIG. 7D

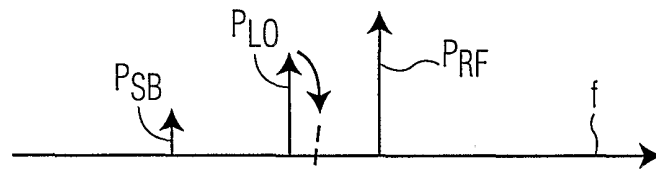

FIG. 8A

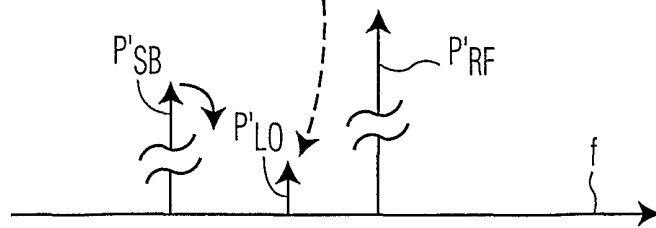

FIG. 8B

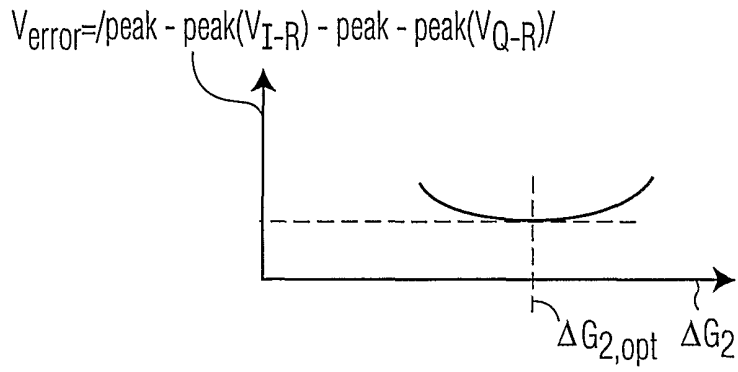

FIG. 9A

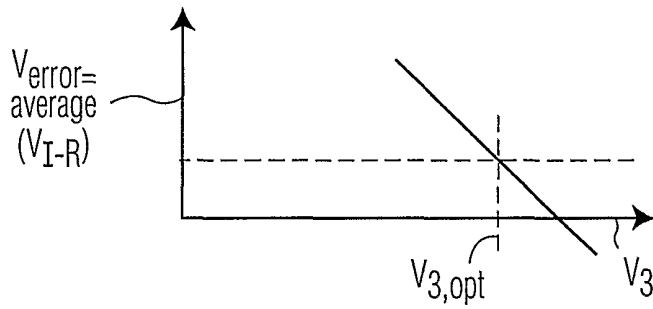

FIG. 9B

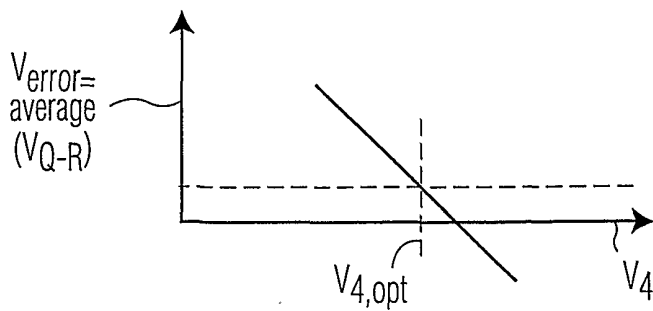

FIG. 9C