

(19) World Intellectual Property Organization
International Bureau



(43) International Publication Date
6 March 2008 (06.03.2008)

PCT

(10) International Publication Number
WO 2008/028078 A2

(51) International Patent Classification:

A61B 17/34 (2006.01) A61N 1/05 (2006.01)
A61M 25/01 (2006.01) A61B 17/70 (2006.01)

(21) International Application Number:

PCT/US2007/077296

(22) International Filing Date: 30 August 2007 (30.08.2007)

(25) Filing Language: English

(26) Publication Language: English

(30) Priority Data:

60/824,064 30 August 2006 (30.08.2006) US
60/824,065 30 August 2006 (30.08.2006) US
60/824,067 30 August 2006 (30.08.2006) US
60/824,066 30 August 2006 (30.08.2006) US
60/824,072 31 August 2006 (31.08.2006) US

(71) Applicant (for all designated States except US): **MED-EL ELEKTROMEDIZINISCHE GERAETE GMBH** [AT/US]; Furstenweg 77a, A-6020 Innsbruck (AT).

(72) Inventors; and

(75) Inventors/Applicants (for US only): **LINDENTHALER,**

Werner [AT/AT]; Volsesgasse 70a, A-6173 Oberperfuss (AT). **FORSTER, Gerhard** [DE/DE]; Am Kochengraben 4, 07749 Jena (DE). **HAGEN, Rudolf** [DE/DE]; Annefrank-str. 39, 97082 Wurzburg (DE). **MULLER, Andreas** [DE/DE]; Landgrafenstieg 12, 07743 Jena (DE).

(74) Agents: **SUNSTEIN, Bruce, D.** et al.; Bromberg & Stein LLP, 125 Summer Street, Boston, MA 02110 (US).

(81) Designated States (unless otherwise indicated, for every kind of national protection available): AE, AG, AL, AM, AT, AU, AZ, BA, BB, BG, BH, BR, BW, BY, BZ, CA, CH, CN, CO, CR, CU, CZ, DE, DK, DM, DO, DZ, EC, EE, EG, ES, FI, GB, GD, GE, GH, GM, GT, HN, HR, HU, ID, IL, IN, IS, JP, KE, KG, KM, KN, KP, KR, KZ, LA, LC, LK, LR, LS, LT, LU, LY, MA, MD, ME, MG, MK, MN, MW, MX, MY, MZ, NA, NG, NI, NO, NZ, OM, PG, PH, PL, PT, RO, RS, RU, SC, SD, SE, SG, SK, SL, SM, SV, SY, TJ, TM, TN, TR, TT, TZ, UA, UG, US, UZ, VC, VN, ZA, ZM, ZW.

(84) Designated States (unless otherwise indicated, for every kind of regional protection available): ARIPO (BW, GH, GM, KE, LS, MW, MZ, NA, SD, SL, SZ, TZ, UG, ZM,

[Continued on next page]

(54) Title: SYSTEM, APPARATUS, AND METHOD FOR FACILITATING INTERFACE WITH LARYNGEAL STRUCTURES

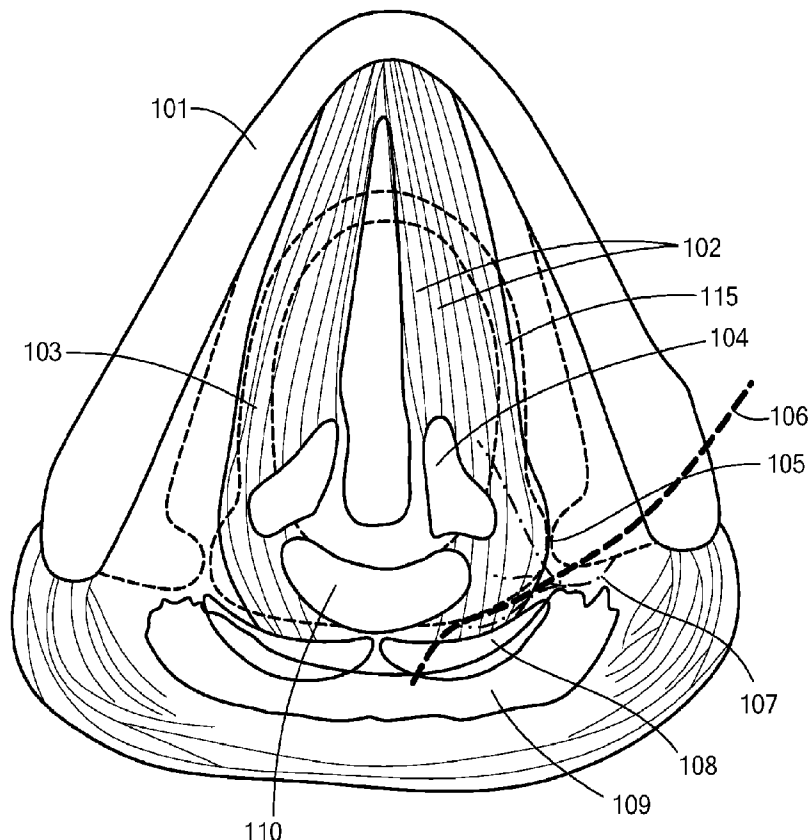

(57) Abstract: Systems and methods of introducing interface elements for interfacing with laryngeal structures of a subject are presented. Illustrative embodiments include a needle insertion technique, positioning and generation of curved or straight tunnels in the subject, and telescoping or curved hollow needle systems and methodologies.

WO 2008/028078 A2



ZW), Eurasian (AM, AZ, BY, KG, KZ, MD, RU, TJ, TM),
European (AT, BE, BG, CH, CY, CZ, DE, DK, EE, ES, FI,
FR, GB, GR, HU, IE, IS, IT, LT, LU, LV, MC, MT, NL, PL,
PT, RO, SE, SI, SK, TR), OAPI (BF, BJ, CF, CG, CI, CM,
GA, GN, GQ, GW, ML, MR, NE, SN, TD, TG).

Published:

— *without international search report and to be republished
upon receipt of that report*

**SYSTEM, APPARATUS, AND METHOD FOR FACILITATING INTERFACE
WITH LARYNGEAL STRUCTURES**

CROSS-REFERENCE TO RELATED APPLICATIONS

[0001] This application claims priority from the following United States Provisional Patent Applications, all of which are hereby incorporated herein by reference in their entireties:

[0002] U.S. Provisional Patent Application No. 60/824,064 entitled Electrode Insertion System and Method for Vocal Chord Stimulation filed August 30, 2006 in the names of Müller and Förster (Attorney Docket No. 1941/A11);

[0003] U.S. Provisional Patent Application No. 60/824,065 entitled Electrode Insertion System and Method for Vocal Chord Stimulation filed August 30, 2006 in the names of Müller and Lindenthaler (Attorney Docket No. 1941/A13);

[0004] U.S. Provisional Patent Application No. 60/824,066 entitled Electrode Insertion System and Method for Vocal Chord Stimulation filed August 30, 2006 in the name of Müller and Förster (Attorney Docket No. 1941/A14);

[0005] U.S. Provisional Patent Application No. 60/824,072 entitled Electrode Insertion System and Method for Vocal Chord Stimulation filed August 31, 2006 in the name of Lindenthaler (Attorney Docket No. 1941/A15); and

[0006] U.S. Provisional Patent Application No. 60/824,067 entitled Electrode Insertion System and Method for Vocal Chord Stimulation filed August 30, 2006 in the name of Hagen (Attorney Docket No. 1941/A16).

[0007] This application is also related to the following U.S. Patent Applications, all of which are being filed on even date herewith and are hereby incorporated herein by reference in their entireties:

[0008] U.S. Patent Application entitled System, Apparatus, and Method for Facilitating Interface with Laryngeal Structures filed in the names of Lindenthaler and Förster (Attorney Docket No. 1941/A48);

[0009] U.S. Patent Application entitled System, Apparatus, and Method for Facilitating Interface with Laryngeal Structures filed in the names of Lindenthaler and Müller (Attorney Docket No. 1941/A49);

[0010] U.S. Patent Application entitled System, Apparatus, and Method for Facilitating Interface with Laryngeal Structures filed in the names of Müller and Förster (Attorney Docket No. 1941/A50);

[0011] U.S. Patent Application entitled System, Apparatus, and Method for Facilitating Interface with Laryngeal Structures filed in the name of Lindenthaler (Attorney Docket No. 1941/A51); and

[0012] U.S. Patent Application entitled System, Apparatus, and Method for Facilitating Interface with Laryngeal Structures filed in the names of Müller, Förster, and Hagen (Attorney Docket No. 1941/A52).

FIELD OF THE INVENTION

[0013] The invention generally relates to an insertion system for laryngeal structures and, more particularly, the invention relates to an interface element (such as an electrode) insertion system and method for facilitating an interface with laryngeal structures (such as vocal cord stimulation).

BACKGROUND OF THE INVENTION

[0014] Functional electrical stimulation ("FES") is the application of stimulation devices to nerves and muscles to treat medical disorders. The most successful FES system to date is the cardiac pacer which has become a routine part of cardiac disease therapy: Lynch, *Cardiovascular Implants*, in *Implants*, Lynch ed., Van Nostrand Rheinhold, New York 1982, incorporated herein by reference. However, there are a variety of other FES systems. The most heavily researched are FES systems to restore locomotion to paraplegics and arm motion to quadriplegics: Peckham, IEEE Trans. Biomed. Eng. 1991, 28: 530, incorporated herein by reference. Other motor control devices restore bladder control to paraplegics and diaphragm function to high quadriplegics: Erlandson, Scand. J. Urol. Nephrol. 44 Suppl: 31, 1978; Glenn, Ann. Surg. 183: 566, 1976, incorporated herein by reference. There are also FES devices designed to rehabilitate the sensory deficits, such as the cochlear implant: Hambrecht, Ann. Otol. Rhinol. Laryngol. 88: 729, 1979, incorporated herein by reference.

[0015] The recurrent laryngeal nerve, which innervates the larynx, contains motor fibers that innervate both the abductor/opener and adductor/closer muscles of the vocal folds. Damage to this nerve compromises both of these functions and arrests the vocal fold just

lateral to the midline. In unilateral paralysis, the voice is breathy and aspiration can occur because of compromised adduction, but airflow during inspiration is minimally impaired. Adequate ventilation of the lungs is assured because abduction of the opposite fold can still occur with each inspiration. In bilateral paralysis, there is a loss of abductory function in both folds, the voice may be minimally impaired because of fold symmetry and their paramedian position in most of the patients, but airway discomfiture is usually severe. Typically, the patient can tolerate restricted activity or may be relegated to a sedentary lifestyle until treatment is administered. In some situations, however, the condition may be life-threatening.

[0016] Clinical management of vocal fold paralysis focuses on the major laryngeal dysfunction associated with each of these two main types. Conventional treatments for unilateral paralysis aim at medializing the fold to improve voice production. Treatment for bilateral paralysis typically requires a tracheotomy to restore sufficient airflow to the lungs. The tracheotomy is left in place until nerve regeneration and muscle reinnervation has returned. However, in many cases, muscle reinnervation is either incomplete or inappropriate resulting in chronic paralysis. Under such conditions, surgical resection of the vocal fold (i.e., cordotomy) is employed to permanently increase the airway and relieve the patient of his tracheotomy. Although these conventional methods of treatment have been useful, they are less than ideal, since they tend to improve upon one laryngeal function at the expense of another. For example, cordotomy improves ventilation, but compromises voice production and airway protection.

[0017] Surgical techniques, such as laser arytenoidectomy and partial cordectomy, can be performed to widen the airway and relieve dyspnea in the case of chronic paralysis. However, these procedures compromise voice and airway protection to restore ventilation through the mouth. They also ignore the long-term effects of ensuing atrophy on vocal fold mass and position. In general, the greater the cartilaginous or membranous resection associated with either technique, the greater the morbidity. A number of modifications of these two strategies have been devised in an attempt to strike a more delicate balance between improved oral ventilation and impaired voice and swallowing. However, a more conservative stance toward resection increases the probability of failed intervention and the necessity for revision surgery. A new, more physiological approach termed laryngeal pacing has been studied in animal models as a means to restore oral ventilation.

[0018] Application of FES to paralyzed laryngeal muscles was introduced into human clinical otolaryngology in 1977 by Zelear DL, Dedo HH, *Control Of Paralyzed Axial*

Muscles By Electrical Stimulation, Acta Otolaryngol (Stockholm) 1977, 83:514–27, incorporated herein by reference, which specifically addressed the case of unilateral vocal fold paralysis. Patients normally breathe well, but they cannot approximate both vocal folds. As a result, their voice is weak and breathy, and they tend to aspirate fluids. Zeale and Dedo proposed that a unilaterally paralyzed patient could be reanimated to close appropriately by electrical stimulation triggered by signals relayed from its contralateral partner. As simpler surgical methods were discovered to restore function in unilateral vocal fold paralysis, the development of an implantable neuroprosthesis for this condition has not been vigorously pursued.

[0019] Mayr, Zrunek, et al., *A Laryngeal Pacemaker For Inspiration Controlled Direct Electrical Stimulation Of Denervated Posterior Cricoarytenoid Muscle In Sheep*, Eur. Arch. Otorhinolaryngol, 248(8):445-448, 1991, incorporated herein by reference, described 8 sheep with denervated PCAs which received implants for from 5-18 months, and ruled out reinnervation by control.

[0020] Obert et al., *Use Of Direct Posterior Cricoarytenoid Stimulation In Laryngeal Paralysis*, Arch. Otolaryngol 1984, 110: 88–92, incorporated herein by reference, restored full abduction in bilaterally denervated dogs implanted with single-stranded teflon electrodes, using 20 ms stimulus pulses delivered at 20-40 Hz and 2-3 mA. Their study suggested that stimulus pulses should be synchronized with inspiratory signals in abductor pacing. Bergmann et al., *Respiratory Rhythmically Regulated Electrical Stimulation Of Paralyzed Muscles*, Laryngoscope, 1984, 94:1376–80, incorporated herein by reference, successfully implanted this idea of respiratory regulation of stimuli, using signals relayed from chest wall expansion. Canine PCA muscles were activated using parameters of 30 Hz, 1 ms, and large amplitudes of up to 50 mA.

[0021] Kano and Sasaki, *Pacing Parameters of the Canine Posterior Cricoarytenoid Muscle*, Ann. Otol. Rhinol. Laryngol., 100:584-588, 1991, incorporated herein by reference, used a pair of coiled electrodes, separated by 2 mm, to stimulate the PCA. They observed promising abductions at 60-90 Hz and 2 ms. Bergmann et al reported 2-3 mm of abduction with stimulation of the PCA using a stimulus delivery system that had been chronically implanted for 11 months.

[0022] Otto et al, *Coordinated Electrical Pacing Of Vocal Cord Abductors In Recurrent Laryngeal Nerve Paralysis*, Otolaryngol. Head Neck Surg., 1985, 93:634–8, incorporated herein by reference, used electromyographic (EMG) signals from the diaphragm

to regulate stimuli to denervated canine PCA muscles, and reportedly restored full abduction of the glottis.

[0023] Zealear and Herzon, *Technical Approach For Reanimation Of The Chronically Denervated Larynx By Means Of Functional Electrical Stimulation*, Ann. Otol. Rhinol. Laryngol., 1994 Sep., 103(9):705-12, incorporated herein by reference, first introduced use of tiny coiled electrodes for abductor pacing in a study of inspiratory trigger sources including tracheal elongation, diaphragm EMG signals, phrenic nerve activity, and intrathoracic pressure changes.

[0024] Zealear et al, *Technical Approach For Reanimation Of The Chronically Denervated Larynx By Means Of Functional Electrical Stimulation*, Ann. Otol. Rhinol. Laryngol. 1994, 103: 705–12, incorporated herein by reference, implanted an electrode array 3 months after RLN section, and the paralyzed stump was electro stimulated to rule out reinnervation. The hot spots were located in the middle of the PCA muscle, several millimeters from the median raphe, and covered 30-40% of the muscle surface area.

[0025] During chronic pacing, it would be desirable to stimulate above the fusion frequency for the PCA muscle so that a smooth abduction of the vocal cord would be achieved. In each animal, the chronically denervated muscle had a lower fusion frequency than its innervated partner. In a chronic implant, it would be desirable to lower the rate of stimulation under 30 Hz closer to that of the fusion frequency (mean: 21.77 Hz) to conserve charge. Figure 3 shows views of a clinical patient with laryngeal hemiplegia both at rest and during stimulation with 4.5 mA at 24 Hz. As the pulse duration was increased, the efficiency in activating chronically denervated muscle increased and surpassed that of the innervated muscle at durations greater than 1-2 ms. However above 2 ms, stimulation became less efficient for both muscles because of charge loss through current shunts normally found in tissue. The amount of vocal cord excursion was only 40-70% of that produced with stimulation of the normally innervated muscle, indicative of denervation atrophy and loss of muscle contractility.

[0026] Sanders I et al., *Arytenoid Motion Evoked By Regional Electrical Stimulation Of The Canine Posterior Cricoarytenoid Muscle*, Laryngoscope. 1994 Apr; 104(4):456-62, incorporated herein by reference, systematically evaluated stimulation delivered to the denervated canine PCA muscles, using single-stranded, stainless steel electrodes 1 cm in length. Measures of abduction were obtained following an overdose of curare designed to mimic vocal fold paralysis via neuromuscular blockade. After RLN section and 2 weeks'

time, measures of abduction were repeated in these animals. Results documented 3 mm of vocal cord excursion with 1 ms, 30 Hz, and 1-50 mA.

[0027] Sanders I., *Electrical Stimulation Of Laryngeal Muscle*, Otolaryngol Clin North Am. 1991 Oct; 24(5):1253-74, incorporated herein by reference, left 4 dogs undisturbed for 6 months to allow atrophy to occur. After 6 months of atrophy, the responses of the animals had decreased to roughly 60% of initial values. The two dogs that did not undergo stimulation continued to atrophy during the following 4 months to 40% of initial values. The two dogs that underwent electrically induced exercise, however, increased their responses dramatically. Not only had their responses returned to normal, but they were uniformly greater than normal, the average approximately 200% that of their initial denervated state. Gross examination of the excised larynges demonstrated that the stimulated group had maintained muscle bulk while the non-stimulated group was noticeably atrophic. Denervated dog PCA could be stimulated with pulses as short as 2 ms. Any lower, and the needed voltage jumped exponentially. Sanders used similar pulse widths to chronically stimulate denervated muscle for months. This is the minimum and presupposes that the electrode is placed directly adjacent to the muscle.

[0028] Zeale DL et al., *Reanimation Of The Paralyzed Human Larynx With An Implantable Electrical Stimulation Device*, Laryngoscope. 2003 Jul; 113(7):1149-56, incorporated herein by reference, reported on four human patients implanted with adapted pain pacemaker systems. In the four patients tested, electromyographic (EMG) motor unit activity was present in the PCA and thyroarytenoid (TA) muscles during voluntary effort. These recordings showed inappropriate firing patterns. For example, inspiratory motor unit activity was recorded from the TA muscle characteristic of a PCA motor unit. In particular, a deep inspiration or sniff increased the rate of firing of individual motor units and enhanced the overall interference response. This inappropriate activity was indicative of synkinetic reinnervation.

[0029] In follow-up sessions, the optimum stimulus parameters for vocal fold abduction were studied. A one- to two-second train of one-millisecond pulses delivered at a frequency of 30 to 40 pulses per second (pps) and amplitude of 2 to 7 V effectively produced a dynamic airway. One to two seconds of stimulated abduction allowed sufficient air exchange with each breath. Although a previous study in the canine found 2-millisecond duration as the optimum pulse width for recruiting both reinnervated and non-reinnervated muscle fibers, the maximum pulse width that the stimulator could deliver was 1 millisecond. A frequency of 30 to 40 pps generated a fused, tetanising muscle contraction and a smooth

vocal fold abduction with maximum opening. The device was set to deliver an average of 10 stimulus sequences (bursts) every minute to match the patient's respiratory rate at a moderate level of activity. The ideal stimulus amplitude was one that evoked maximum vocal fold opening without inducing discomfort or nociception. At this amplitude, the patient could feel the stimulus, which helped entrain inspiration to the stimulus cycle. Stimulated abduction significantly increased the magnitude of glottal opening in patients 1 to 5 from preoperative levels ($P < .0008$). Stimulated glottal opening was large in patients 1, 3, and 4 (3.5-7 mm) and moderate in patient 2 (3 mm). In patient 5, stimulation also produced a large abduction of 4 mm, but the response was delayed in time.

[0030] In order to decrease current spread and the high power requirements of FES devices, the placement of electrodes should localize current to the target muscle or nerve (if the muscle is innervated – even if it is synkinetically reinnervated) as much as possible. This may be accomplished by placing the electrodes inside the muscle, or on its surface, a procedure that produces two technical problems: (1) surgical exposure of the muscle causes scarring which eventually decreases muscle mobility; and (2) because electrodes must be close to their target to be efficient, they are exposed to muscle movement. The constant abrasion of the electrode against the muscle breaks the electrode or causes extensive fibrosis in the muscle. This difficulty plagued the early development of the cardiac pacer and persists today in many experiments involving chronic stimulation of denervated muscle, including the denervated PCA. As a result, there has not been a truly successful chronic device for stimulation of denervated muscle.

[0031] In 1992 for unilateral vocal cord paralysis, Goldfarb used the electric activity of the healthy side as a trigger for synchronization with breathing and vocalization. See, U.S. Patent No. 5,111,814. This method is not applicable for the clinically more relevant bilateral paralysis. Lindenthaler described a pacemaker for bilateral vocal cord palsy due to autoperalysis (equivalent to synkinetic Recurrent Laryngeal Nerve (RLN) reinnervation), which is triggered by another muscle or nerve signal that is activated synchronic to breathing, e.g., diaphragm breathing muscles, infrahyoid muscles of the neck. The pacemaker then stimulates structurally intact but autoperalytic nerve. See, U.S. Patent No. 7,069,082.

[0032] For a real and complete rehabilitation of some patients with uni- or bilateral vocal cord paralysis or even in patients with a larynx transplantation a mere restoration of a single movement function of vocal cords by a pacemaker is not sufficient. In some cases even essential, is a pacemaker that can stimulate opening of vocal cords (e.g., to achieve sufficient breath for physical activities) as well as complete closure and tension of vocal cords (e.g., for

vocalization and in combination with larynx elevation during swallowing for protection against aspiration). An optimal coordination of stimulated larynx movements with breathing cycle, intentional vocalization and swallowing reflex is necessary for that.

[0033] A stimulation of opening and closing of vocal cords might be helpful to preserve the full dynamic range of vocal cord movability by preventing a fixation of the cricoarytenoid joint. The necessary electrodes or sensing devices for detecting triggers and for stimulation of autoparalytic nerves or direct stimulation of paralyzed muscles of the larynx itself must not damage healthy tissue. In addition, the implantation procedure should also not cause harm.

[0034] Current surgical techniques all involve the exposure of the endings of the RLN or the exposure of the opening muscle (i.e., Posterior Cricoarytenoid Muscle, (PCA)) of the larynx. To achieve this, other muscles have to be cut (e.g., infrahyoidal muscles or pharyngeal constrictor muscle) and vessels and nerves in the vicinity may be damaged causing an impaired mobility of the larynx during swallowing and impaired sensitivity of mucus membranes with an increased risk of foreign body aspiration. Furthermore, scarring of all those tissues may diminish stimulated movements in the long run.

[0035] In addition, free placement of electrodes through the tissue to the target muscle (or nerve) may cause a high mechanical stress in the electrode leads which may cause lead wire breakage in delicate electrodes. Thus, placing or laying of the electrode in such a way that protects the electrode more may be helpful.

[0036] In order to decrease current spread and the high power requirements of FES devices, the placement of electrodes should localize current to the target muscle or nerve (if the muscle is innervated – even if it is synkinetically reinnervated) as much as possible. This may be accomplished by placing the electrodes inside the muscle or at its surface, a procedure that produces two technical problems: (1) surgical exposure of the muscle causes scarring which eventually decreases the muscle's mobility; and (2) because electrodes must be close to their target to be efficient, they are exposed to muscle movement. The constant abrasion of the electrode against muscle breaks the electrode or causes extensive fibrosis in the muscle. This difficulty plagued the early development of the cardiac pacer and persists today in many experiments involving chronic stimulation of denervated muscle, including the denervated PCA. As a result, there is not currently a truly successful chronic device for stimulation of denervated muscle.

[0037] An open surgery is much more invasive than a needle insertion. Insertion needles or puncture needles are typically straight and not curved, consisting of one part. For

some situations, however, it is not possible to reach the target point (e.g., inside the subject's body or a different position outside the body than where the insertion started) in a straight line from the outside of the body or starting from cavities inside the body.

SUMMARY OF THE INVENTION

[0038] In accordance with one aspect of the invention there is provided a method of positioning interface elements for interfacing with laryngeal structures of a subject such as for diagnosis or treatment of a laryngeal impairment. The method involves positioning a needle in geographical relation to the lateral wing of a vocal cord cartilage and positioning at least one interface element via the needle.

[0039] In various alternative embodiments, vocal cord cartilage may include cricoid cartilage and/or thyroid cartilage. The geographical relation to the lateral wing of a vocal cord cartilage may be subperichondral on an inside of cricoid cartilage lamina. The geographical relation to the lateral wing of a vocal cord cartilage may be on an outside of cricoid cartilage lamina. The geographical relation to the lateral wing of a vocal cord cartilage may be inside of a cricoid cartilage wall, for example, formed in a curve in the inside of the cricoid cartilage wall. An insertion route of the needle may be partly inside of a cricoid cartilage wall and partly subperichondral on an inside of cricoid cartilage lamina. An insertion route of the needle may be partly inside of a cricoid cartilage wall and partly on the outside of cricoid cartilage lamina.

[0040] In various alternative embodiments, an interface element may be positioned, implanted temporarily, implanted permanently, brought in place, inserted, and/or affixed. An interface element may include an electrode, a sensor, a catheter, a delivery device, a heat delivery device, a cold delivery device, a surgical device, a needle, a probe, a light transmission device, a tissue, a bulking material, light, heat, cold, fluid, drug, medicine, nutrient, radiation, or material. A laryngeal impairment may include unilateral vocal cord paralysis, bilateral vocal cord paralysis, dysphonia, dysphagia, and/or tendency of aspiration. A single interface element may be positioned unilaterally, multiple interface elements may be positioned unilaterally, or multiple interface elements may be positioned bilaterally. An interface element may be placed in communication with a controller that is implanted into the subject. A plurality of interface elements may be placed in communication with a controller that independently controls the interface elements, or each of a plurality of interface elements may be placed in communication with a separate controller such that each interface element is independently controlled by its respective controller.

[0041] In various alternative embodiments, certain aspects of the method may be performed in the surgical field of a neck incision and may be visually monitored intraoperatively, monitored intraoperatively by neural monitoring, monitored intraoperatively by monitoring of electromyographical signals, and/or performed endoscopically. Navigation of the interface element(s) and/or other implements may be performed using palpation, x-ray, CT, MRI, electrical test stimulators, a schablone manufactured according to general or the specific computer tomography data of the subject, a mask of the throat and mandible, and/or by use of a 2 or more dimensional video navigation system in relation to at least one of computer tomography, X-ray, MRI, and ultrasound data of the subject. Various elements may be repositioned, for example, with a different angle, a different direction, or a different starting point.

[0042] In various alternative embodiments, at least one laryngeal structure (e.g., a single vocal cord, both vocal cords, the epiglottis, or a pharyngeal constrictor) may be interfaced using the interface element(s), and the interface element(s) may be positioned for interfacing with a muscle, nerve, or receptor. Such interfacing may include, among other things stimulating a laryngeal structure, activating a laryngeal structure, blocking a laryngeal structure, inhibiting operation of a laryngeal structure, moving a laryngeal structure, removing a portion of a laryngeal structure, repairing a laryngeal structure, delivering a material to a laryngeal structure, or monitoring a laryngeal structure. Moving a laryngeal structure may include opening, closing, or varying tension of the laryngeal structure. The interfacing may include receiving and/or recording electromyographic signals of a related muscle and/or may include receiving and/or recording electroneurographic signals of a related nerve. In various alternative embodiments, various types of stimuli (e.g., electrical energy or drugs) may be delivered to a laryngeal structure via the interface element(s).

[0043] In certain embodiments, the interface element may include an electrode, in which case a portion of the electrode may be routed percutaneously through the skin to the outside of the subject and connected to an external stimulator for a certain duration to verify efficacy of the interfacing with laryngeal structures. In other embodiments, the interface element may include a sensor, in which case a portion of the sensor may be routed percutaneously through the skin to the outside of the subject and connected to an external recorder for a certain duration to verify efficacy of the interfacing with laryngeal structures. In yet other embodiments, the interface element may include a catheter, in which case a portion of the catheter may be routed percutaneously through the skin to the outside of the subject and connected to an external pump for a certain duration to verify efficacy of the

interfacing with laryngeal structures. In some embodiments, the certain duration may be from 1 to 60 minutes. In other embodiments, the certain duration may be from 1 to 24 hours. In yet other embodiments, the certain duration may be from 1 to 7 days. In still other embodiments, the certain duration may be from 1 to 20 weeks. An interface element (e.g., an electrode, sensor, or catheter) may be permanently connected to a surgically implanted controller (e.g., a stimulator, recording device, or pump) in the case efficacy is proven or may be removed from the subject in the case efficacy has not been proven.

[0044] In accordance with another aspect of the invention there is provided a method of employing an electrode in a subject with laryngeal impairments in order to facilitate movement of vocal cords. The method involves inserting a thread into a subperichondral space beneath posterior cricoarytenoid muscle, attaching an electrode to the thread, and placing the electrode near a related structure by pulling the thread.

[0045] In various alternative embodiments, movement of vocal cords may include opening, closing, or varying tension of the vocal cords. Laryngeal impairments may include unilateral vocal cord paralysis, bilateral vocal cord paralysis, dysphonia, dysphagia, or tendency of aspiration. Other types of interface elements may be used in place of, or in addition to, an electrode to cause movement or other desired manipulation of the vocal cords or other laryngeal structures.

[0046] In various alternative embodiments, the thread may be inserted into the subperichondral space beneath the posterior cricoarytenoid muscle and cartilage from a back side of a larynx. Insertion of the thread may be done, for example, endoscopically or with a needle. The thread may be removed from the needle before the thread is attached to the electrode or may be retrieved after placing the electrode, e.g., via a surgical neck incision.

[0047] In various alternative embodiments, placing the electrode may include optimizing a position of the electrode by moving the electrode via pulling the thread or pulling the electrode and visually controlling the vocal cord movement intraoperatively. An electrode may be placed unilaterally, and multiple electrodes may be placed unilaterally or bilaterally. The related structure may be, for example, a muscle or nerve and may be activated, for example, by electrical energy or drug delivered via the electrode. Additionally, or alternatively, signals (e.g., electromyographic signals of a related muscle or electroneurographic signals of a related nerve) may be sensed using the electrode. In the above embodiments, the electrode may be attached to the thread outside a body of the subject or in an area where surgery is performed on the subject, or in a vicinity of the area.

[0048] In accordance with another aspect of the invention there is provided a method of introducing interface elements for interfacing with laryngeal structures of a subject such as for diagnosis or treatment of a laryngeal impairment. The method involves generating a tunnel in geographical relation to the lateral wing of the cricoid cartilage of the subject and introducing at least one interface element via the tunnel for interfacing with at least one laryngeal structure of the subject.

[0049] In various alternative embodiments, at least a portion of the tunnel may be subperichondral on an inside of cricoid cartilage lamina. A portion of the tunnel may be on an outside of cricoid cartilage lamina. A portion of the tunnel may be inside of a cricoid cartilage wall, for example, formed in a curve in the inside of the cricoid cartilage wall. A portion of the tunnel may be partly inside of a cricoid cartilage wall and partly subperichondral on an inside of cricoid cartilage lamina. A portion of the tunnel may be partly inside of a cricoid cartilage wall and partly on the outside of cricoid cartilage lamina.

[0050] In various alternative embodiments, an interface element may be positioned, implanted temporarily, implanted permanently, brought in place, inserted, and/or affixed. An interface element may include an electrode, a sensor, a catheter, a delivery device, a heat delivery device, a cold delivery device, a surgical device, a needle, a probe, a light transmission device, a tissue, a bulking material, light, heat, cold, fluid, drug, medicine, nutrient, radiation, or material. A laryngeal impairment may include unilateral vocal cord paralysis, bilateral vocal cord paralysis, dysphonia, dysphagia, and/or tendency of aspiration. A single interface element may be positioned unilaterally, multiple interface elements may be positioned unilaterally, or multiple interface elements may be positioned bilaterally. An interface element may be placed in communication with a controller that is implanted into the subject. A plurality of interface elements may be placed in communication with a controller that independently controls the interface elements, or each of a plurality of interface elements may be placed in communication with a separate controller such that each interface element is independently controlled by its respective controller.

[0051] In various alternative embodiments, certain aspects of the method may be performed in the surgical field of a neck incision and may be visually monitored intraoperatively, monitored intraoperatively by neural monitoring, monitored intraoperatively by monitoring of electromyographical signals, and/or performed endoscopically. Navigation of the interface element(s) and/or other implements may be performed using palpation, x-ray, CT, MRI, electrical test stimulators, a schablone manufactured according to general or the specific computer tomography data of the subject, a mask of the throat and mandible, and/or

by use of a 2 or more dimensional video navigation system in relation to at least one of computer tomography, X-ray, MRI, and ultrasound data of the subject. Various elements may be repositioned, for example, with a different angle, a different direction, or a different starting point.

[0052] In various alternative embodiments, at least one laryngeal structure (e.g., a single vocal cord, both vocal cords, the epiglottis, or a pharyngeal constrictor) may be interfaced using the interface element(s), and the interface element(s) may be positioned for interfacing with a muscle, nerve, or receptor. Such interfacing may include, among other things stimulating a laryngeal structure, activating a laryngeal structure, blocking a laryngeal structure, inhibiting operation of a laryngeal structure, moving a laryngeal structure, removing a portion of a laryngeal structure, repairing a laryngeal structure, delivering a material to a laryngeal structure, or monitoring a laryngeal structure. Moving a laryngeal structure may include opening, closing, or varying tension of the laryngeal structure. The interfacing may include receiving and/or recording electromyographic signals of a related muscle and/or may include receiving and/or recording electroneurographic signals of a related nerve. In various alternative embodiments, various types of stimuli (e.g., electrical energy or drugs) may be delivered to a laryngeal structure via the interface element(s).

[0053] In certain embodiments, the interface element may include an electrode, in which case a portion of the electrode may be routed percutaneously through the skin to the outside of the subject and connected to an external stimulator for a certain duration to verify efficacy of the interfacing with laryngeal structures. In other embodiments, the interface element may include a sensor, in which case a portion of the sensor may be routed percutaneously through the skin to the outside of the subject and connected to an external recorder for a certain duration to verify efficacy of the interfacing with laryngeal structures. In yet other embodiments, the interface element may include a catheter, in which case a portion of the catheter may be routed percutaneously through the skin to the outside of the subject and connected to an external pump for a certain duration to verify efficacy of the interfacing with laryngeal structures. In some embodiments, the certain duration may be from 1 to 60 minutes. In other embodiments, the certain duration may be from 1 to 24 hours. In yet other embodiments, the certain duration may be from 1 to 7 days. In still other embodiments, the certain duration may be from 1 to 20 weeks. An interface element (e.g., an electrode, sensor, or catheter) may be permanently connected to a surgically implanted controller (e.g., a stimulator, recording device, or pump) in the case efficacy is proven or may be removed from the subject in the case efficacy has not been proven.

[0054] In accordance with another aspect of the invention there is provided a method of introducing interface elements for interfacing with laryngeal structures of a subject such as for diagnosis or treatment of a laryngeal impairment. The method involves generating a tunnel in geographical relation to the lateral wing of the thyroid cartilage of the subject and introducing at least one interface element via the tunnel for interfacing with at least one laryngeal structure of the subject.

[0055] The tunnel may be generated at least in part by introduction of an interface element. In various alternative embodiments, a portion of the tunnel may be medial of the thyroid cartilage. The tunnel may include a part of a subperichondral tunnel on an inside of thyroid cartilage lamina. The tunnel may include a part of a subperichondral tunnel on an outside of thyroid cartilage lamina. The tunnel may include a part of a tunnel drilled inside of a thyroid cartilage wall., for example, formed in a curve in the inside of the thyroid cartilage wall. The tunnel may be drilled partly inside of a cricoid cartilage wall and may include a subperichondral tunnel on an inside of cricoid cartilage lamina. The tunnel may be drilled partly inside of a cricoid cartilage wall and partly on the outside of cricoid cartilage lamina.

[0056] In various alternative embodiments, an interface element may be positioned, implanted temporarily, implanted permanently, brought in place, inserted, and/or affixed. An interface element may include an electrode, a sensor, a catheter, a delivery device, a heat delivery device, a cold delivery device, a surgical device, a needle, a probe, a light transmission device, a tissue, a bulking material, light, heat, cold, fluid, drug, medicine, nutrient, radiation, or material. A laryngeal impairment may include unilateral vocal cord paralysis, bilateral vocal cord paralysis, dysphonia, dysphagia, and/or tendency of aspiration. A single interface element may be positioned unilaterally, multiple interface elements may be positioned unilaterally, or multiple interface elements may be positioned bilaterally. An interface element may be placed in communication with a controller that is implanted into the subject. A plurality of interface elements may be placed in communication with a controller that independently controls the interface elements, or each of a plurality of interface elements may be placed in communication with a separate controller such that each interface element is independently controlled by its respective controller.

[0057] In various alternative embodiments, certain aspects of the method may be performed in the surgical field of a neck incision and may be visually monitored intraoperatively, monitored intraoperatively by neural monitoring, monitored intraoperatively by monitoring of electromyographical signals, and/or performed endoscopically. Navigation of the interface element(s) and/or other implements may be performed using palpation, x-ray,

CT, MRI, electrical test stimulators, a schablone manufactured according to general or the specific computer tomography data of the subject, a mask of the throat and mandible, and/or by use of a 2 or more dimensional video navigation system in relation to at least one of computer tomography, X-ray, MRI, and ultrasound data of the subject. Various elements may be repositioned, for example, with a different angle, a different direction, or a different starting point.

[0058] In various alternative embodiments, at least one laryngeal structure (e.g., a single vocal cord, both vocal cords, the epiglottis, or a pharyngeal constrictor) may be interfaced using the interface element(s), and the interface element(s) may be positioned for interfacing with a muscle, nerve, or receptor. Such interfacing may include, among other things stimulating a laryngeal structure, activating a laryngeal structure, blocking a laryngeal structure, inhibiting operation of a laryngeal structure, moving a laryngeal structure, removing a portion of a laryngeal structure, repairing a laryngeal structure, delivering a material to a laryngeal structure, or monitoring a laryngeal structure. Moving a laryngeal structure may include opening, closing, or varying tension of the laryngeal structure. The interfacing may include receiving and/or recording electromyographic signals of a related muscle and/or may include receiving and/or recording electroneurographic signals of a related nerve. In various alternative embodiments, various types of stimuli (e.g., electrical energy or drugs) may be delivered to a laryngeal structure via the interface element(s).

[0059] In certain embodiments, the interface element may include an electrode, in which case a portion of the electrode may be routed percutaneously through the skin to the outside of the subject and connected to an external stimulator for a certain duration to verify efficacy of the interfacing with laryngeal structures. In other embodiments, the interface element may include a sensor, in which case a portion of the sensor may be routed percutaneously through the skin to the outside of the subject and connected to an external recorder for a certain duration to verify efficacy of the interfacing with laryngeal structures. In yet other embodiments, the interface element may include a catheter, in which case a portion of the catheter may be routed percutaneously through the skin to the outside of the subject and connected to an external pump for a certain duration to verify efficacy of the interfacing with laryngeal structures. In some embodiments, the certain duration may be from 1 to 60 minutes. In other embodiments, the certain duration may be from 1 to 24 hours. In yet other embodiments, the certain duration may be from 1 to 7 days. In still other embodiments, the certain duration may be from 1 to 20 weeks. An interface element (e.g., an electrode, sensor, or catheter) may be permanently connected to a surgically implanted

controller (e.g., a stimulator, recording device, or pump) in the case efficacy is proven or may be removed from the subject in the case efficacy has not been proven.

[0060] In accordance with another aspect the invention, a system for positioning an interface element includes one or more hollow members adapted to telescope into an outermost hollow member. The outermost hollow member has a structure at a first end. When a portion of a hollow member is extending from the outermost hollow member, the hollow member is at an angle relative to the outermost hollow member due to the structure. The interface element is capable of being moved through at least one of the hollow members from a first position to a second position.

[0061] In accordance with related embodiments of the invention, at least one of the first position and second position may be a position on skin of a subject, a position on a border of a cavity inside a body of a subject, a position inside a body of a subject, and a position on a surface and/or inside an organ in a body of a subject.

[0062] In accordance with further related embodiments, the system may include the interface element. The interface element may be an electrode, a sensor, a catheter, a delivery device, a heat delivery device, a cold delivery device, a surgical device, a probe, a light transmission device, a tissue, a material, a bulking material, a needle, heat, cold, fluid, drug, medicine, nutrient, and/or radiation. The interface element may be adapted to interface with at least one laryngeal structure. The interface element may be adapted to: stimulate at least one of the laryngeal structures; activate the laryngeal structures; block the laryngeal structures; inhibit operation of the laryngeal structures; move the laryngeal structures; remove a portion of the laryngeal structures; repair the laryngeal structures; and/or deliver a material to the laryngeal structures.

[0063] In accordance with further related embodiments of the invention, the hollow member(s) may be capable of retracting after the interface element is transported between the first position and the second position. The structure at the tip may include a curved member and/or an angled member. The structure may include means for bending a hollow member upon extending from the tip of the outermost hollow member, and for straightening a hollow member upon retracting into the tip of the outermost hollow member. At least one of the hollow members may be a hollow needle.

[0064] In accordance with another aspect of the invention, a method of positioning an interface element includes inserting a telescoping unit. The telescoping unit includes one or more hollow members adapted to telescope into an outermost hollow member, with the outermost hollow member having a structure at a first end. A portion of at least one hollow

member is extended beyond the tip of the outermost hollow member such that that at least one hollow member is at an angle relative to the outermost hollow member due to the structure.

[0065] In accordance with related embodiments of the invention, the method may further include extending at least one of the hollow members. The interface element may be moved through at least one of the hollow members from a first position to a second position. The method may further include retracting at least one of the hollow members. The interface element may be an electrode, a sensor, a catheter, a delivery device, a heat delivery device, a cold delivery device, a surgical device, a probe, a light transmission device, a tissue, a material, a bulking material, a needle, heat, cold, fluid, drug, medicine, nutrient, and/or radiation. The interface element may be adapted to interface with at least one laryngeal structure. The interface element may be adapted to: stimulate at least one of the laryngeal structures; activate the laryngeal structures; block the laryngeal structures; inhibit operation of the laryngeal structures; move the laryngeal structures; remove a portion of the laryngeal structures; repair the laryngeal structures; and/or deliver a material to the laryngeal structures.

[0066] In accordance with still further related embodiments of the invention, at least one of the first position and second position may be a position on skin of a subject, a position on a border of a cavity inside a body of a subject, a position inside a body of a subject, and a position on a surface and/or inside an organ in a body of a subject. The telescoping unit may be inserted endoscopically. The structure at the tip may be a curved member and/or an angled member.

[0067] In accordance with another aspect of the invention, a system for transporting at least one interface element from a first location related to a subject to a second location related to the subject is presented. The system includes an outer hollow member having an inner surface with a first diameter and a structure at a tip of the outer hollow member. An inner hollow member has an outer surface with a second diameter, wherein the second diameter is smaller than the first diameter so that the inner hollow member fits within the inner surface of the outer hollow member. The inner hollow member is at an angle relative to the outer hollow member due to the structure at the tip of the outer hollow member when a portion of the inner hollow member extends beyond the tip of the outer hollow member.

[0068] In accordance with related embodiments of the invention, the inner hollow member may further include an inner surface having a third diameter and a structure at a tip of the inner hollow member. A second inner hollow member has an outer surface with a

fourth diameter. The fourth diameter is smaller than the third diameter so that the second inner hollow member fits within the inner surface of the inner hollow member.

[0069] The second inner hollow member is at an angle relative to the inner hollow member due to the structure at the tip of the inner hollow member when a portion of the second inner hollow member extends beyond the tip of the inner hollow member.

[0070] In accordance with further related embodiments of the invention, at least one of the first location and the second location is at least one of a position on skin of the subject, a position on a border of a cavity inside a body of the subject, a position inside a body of a subject, and a position on a surface or inside an organ in a body of the subject.

[0071] In accordance with still further related embodiments of the invention, the interface element may be an electrode, a sensor, a catheter, a delivery device, a heat delivery device, a cold delivery device, a surgical device, a probe, a light transmission device, a tissue, a material, a bulking material, a bulking material, a needle, heat, cold, fluid, drug, medicine, nutrient, and/or radiation. The interface element may be adapted to interface with at least one laryngeal structure. The interface element may be adapted to: stimulate at least one of the laryngeal structures; activate the laryngeal structures; block the laryngeal structures; inhibit operation of the laryngeal structures; move the laryngeal structures; remove a portion of the laryngeal structures; repair the laryngeal structures; and/or deliver a material to the laryngeal structures.

[0072] In accordance with another related embodiment of the invention, the system may be capable of retracting after the interface element is transported between the first and second locations. The structure at the tip may include a curved member and/or an angled member.

[0073] In accordance with another aspect of the invention, a method for transporting at least one interface element from a first location related to a subject to a second location related to the subject is presented. The method includes inserting a curved hollow arrangement, the curved hollow arrangement including an outer hollow member and an inner hollow member. The outer hollow member has an inner surface with a first diameter and a structure at a tip of the outer hollow member. The inner hollow member has an outer surface with a second diameter, wherein the second diameter is smaller than the first diameter so that the inner hollow member fits within the inner surface of the outer hollow member. When extending a portion of the inner hollow member beyond the tip of the outer hollow member, the inner hollow member is at an angle relative to the outer hollow member due to the structure at the tip of the outer hollow member.

[0074] In accordance with related embodiments of the invention, the inner hollow member further may include an inner surface with a third diameter and a structure at a tip of the inner hollow member. A second inner hollow member has an outer surface with a fourth diameter, wherein the fourth diameter is smaller than the third diameter so that the second inner hollow member fits within the inner surface of inner hollow member. The method may further include extending a portion of the second inner hollow member beyond the tip of the inner hollow member such that the second inner hollow member is at an angle relative to the inner hollow member due to the structure at the tip of the inner hollow member.

[0075] In accordance with further related embodiments of the invention, the first location and/or second location may be a position on skin of a subject, a position on a border of a cavity inside a body of a subject, a position inside a body of a subject, and a position on a surface and/or inside an organ in a body of a subject. The at least one interface element may be an electrode, a sensor, a catheter, a delivery device, a heat delivery device, a cold delivery device, a surgical device, a probe, a light transmission device, a tissue, a material, a bulking material, a bulking material, a needle, heat, cold, fluid, drug, medicine, nutrient, and/or radiation. The curved hollow arrangement may be inserted endoscopically. The curved hollow arrangement may be retracted after the at least one interface element is transported between the first and second locations. The structure at the tip may include a curved member and/or an angled member.

[0076] In accordance with another aspect of the invention, a system for transporting at least one interface element from a first location related to a subject to a second location related to the subject is presented. An outer hollow member has a tip and an inner surface with a first diameter. A curved inner hollow member has an outer surface with a second diameter, wherein the second diameter is smaller than the first diameter so that the curved inner hollow member fits within the inner surface of the outer hollow member. The curved inner hollow member is at an angle relative to the outer hollow member when a portion of the curved inner hollow member extends beyond the tip of the outer hollow member.

[0077] In accordance with related embodiments of the invention, the curved inner hollow member may further include a tip and an inner surface having a third diameter. A second curved inner hollow member has an outer surface with a fourth diameter, wherein the fourth diameter is smaller than the third diameter so that the second curved inner hollow member fits within the inner surface of the curved inner hollow member. The second curved inner hollow member is at an angle relative to the curved inner hollow member when a

portion of the second curved inner hollow member extends beyond the tip of the curved inner hollow member.

[0078] In accordance with further related embodiments of the invention, the first location and/or the second location may be: a position on skin of the subject; a position on a border of a cavity inside a body of the subject; a position inside a body of a subject; and/or a position on a surface or inside an organ in a body of the subject. The at least one interface element may be an electrode, a sensor, a catheter, a delivery device, a heat delivery device, a cold delivery device, a surgical device, a probe, a light transmission device, a tissue, a material, a bulking material, a needle, heat, cold, fluid, drug, medicine, nutrient, and/or radiation.. The system may be capable of retracting after the at least one interface element is transported between the first and second locations. The structure at the tip of the outer hollow member may include a curved part and/or an angled part.

[0079] In accordance with another aspect of the invention, a method for transporting at least one interface element from a first location related to a subject to a second location related to the subject is presented. The method includes inserting a curved hollow arrangement, the curved hollow arrangement including an outer hollow member and a curved inner hollow member. The outer hollow member has a tip and an inner surface with a first diameter and the curved inner hollow member has an outer surface with a second diameter. The second diameter is smaller than the first diameter so that the curved inner hollow member fits within the inner surface of the outer hollow member. When a portion of the curved inner hollow member extends beyond the tip of the outer hollow member, the inner hollow member is at an angle relative to the outer hollow member.

[0080] In accordance with a related embodiment of the invention, the curved inner hollow member may further include a tip and an inner surface having a third diameter. A second curved inner hollow member has an outer surface with a fourth diameter, wherein the fourth diameter is smaller than the third diameter so that the second curved inner hollow member fits within the inner surface of curved inner hollow member. The method further includes extending a portion of the second curved inner hollow member beyond the tip of the curved inner hollow member such that the second curved inner hollow member is at an angle relative to the curved inner hollow member.

[0081] In accordance with further related embodiments of the invention, the first location and/or the second location may be: a position on skin of the subject; a position on a border of a cavity inside a body of the subject; a position inside a body of a subject; and/or a position on a surface or inside an organ in a body of the subject. The at least one interface

element may be an electrode, a sensor, a catheter, a delivery device, a heat delivery device, a cold delivery device, a surgical device, a probe, a light transmission device, a tissue, a material, a bulking material, a needle, heat, cold, fluid, drug, medicine, nutrient, and/or radiation. The system may be capable of retracting after the at least one interface element is transported between the first and second locations. The structure at the tip of the outer hollow member may include a curved part and/or an angled part. The curved hollow arrangement may be inserted endoscopically. The curved hollow arrangement may be retracted after the at least one interface element is transported between the first and second locations.

[0082] In accordance with another aspect of the invention, a system for providing a path between two targets of a subject so as to transport at least one interface element from one target to the other target is presented. The system includes a first outer hollow member, with a structure at the tip of the first outer member. A second inner hollow member has a smaller diameter than the first outer hollow member so that the second inner hollow member fits into the first outer hollow member. The second inner hollow member leaves the first outer member in a relative angle when moving the second inner hollow member outside the first outer hollow member because of the structure at the tip of the first outer member.

[0083] In accordance with a related embodiment of the invention, there may be a structure at the tip of the second inner member. A third inner hollow member has a smaller diameter than the second inner hollow member so that the third inner hollow member fits into the second inner hollow member. The third inner hollow member leaves the second inner member in a relative angle when moving the third inner hollow member outside the second inner hollow member because of the structure at the tip of the second inner member.

[0084] In accordance with another aspect of the invention, a method for providing a path between two targets of a subject so as to transport at least one interface element from one target to the other by a curved hollow member is presented. The method includes inserting a first outer hollow member, the first outer hollow member having a structure at a tip of the first outer member. A second inner hollow member has a smaller diameter than the first outer hollow member so that the second inner hollow member fits into the first outer hollow member. The second inner hollow member leaves the first outer member in a relative angle when extending the second inner hollow member beyond the first outer hollow member because of the structure at the tip of the first outer member.

[0085] In accordance with a related embodiment of the invention, the second inner member may have a structure at a tip of the second inner member. A third inner hollow member has a smaller diameter than the second inner hollow member so that the third inner hollow member fits into the second inner hollow member. The third inner hollow member leaves the second inner member in a relative angle when extending the third inner hollow member beyond the second inner hollow member because of the structure at the tip of the second inner member.

[0086] In accordance with another aspect of the invention, a system for providing a path between two targets of a subject so as to transport at least one interface element from one target to the other is presented. The system includes a first outer hollow member. A second inner hollow member has a smaller diameter than the first outer hollow member so that the second inner hollow member fits into the first outer hollow member. The second inner hollow member curves relative to the first outer hollow member when moving the second inner hollow member outside the first outer hollow member because of a pre-manufactured curve of the second inner hollow member. The second inner hollow member is not curved relative to the first outer hollow member while the second inner hollow member is tight against the first outer member.

[0087] In accordance with a related embodiment of the invention, a third inner hollow member may have a smaller diameter than the second inner hollow member so that the third inner hollow member fits into the second inner hollow member. The third inner hollow member curves relative to the second inner hollow member when moving the third inner hollow member outside the second inner hollow member because of pre-manufactured different curve of the third inner hollow member. The third inner hollow member is not curved relative to the second outer hollow member while the third inner hollow member is tight against the second inner member.

[0088] In accordance with another aspect of the invention there is provided a method of positioning an interface element for interfacing with laryngeal structures in a subject such as for diagnosis or treatment of a laryngeal impairment. The method involves inserting a curved hollow needle system into a subperichondral space beneath posterior cricoarytenoid muscle from the larynx; pushing the curved hollow needle system in a curve around cartilage at least until the curved hollow needle is seen from outside of a body of the subject; retracting the curved hollow needle system back into the larynx along a retraction route; and positioning at least one interface element at a desired position along the retraction route.

[0089] In various alternative embodiments, one or more interface elements may be inserted into the curved hollow needle system after the needle system has left the skin. One or more interface elements may be pre-disposed within the hollow curved needle system, and positioning of an interface element may occur at least in part upon retraction of the needle system. The curved hollow needle system may include a thread connected to the at least one interface element, and positioning of an interface element may occur at least in part upon retraction of the needle system and consequent pulling on the thread. The curved needle system may be inserted into the subperichondral space beneath the posterior cricoarytenoid muscle and cartilage from a back side of the larynx.

[0090] In various alternative embodiments, an interface element may be positioned, implanted temporarily, implanted permanently, brought in place, inserted, and/or affixed. An interface element may include an electrode, a sensor, a catheter, a delivery device, a heat delivery device, a cold delivery device, a surgical device, a needle, a probe, a light transmission device, a tissue, a bulking material, light, heat, cold, fluid, drug, medicine, nutrient, radiation, or material. A laryngeal impairment may include unilateral vocal cord paralysis, bilateral vocal cord paralysis, dysphonia, dysphagia, and/or tendency of aspiration. A single interface element may be positioned unilaterally, multiple interface elements may be positioned unilaterally, or multiple interface elements may be positioned bilaterally. An interface element may be placed in communication with a controller that is implanted into the subject. A plurality of interface elements may be placed in communication with a controller that independently controls the interface elements, or each of a plurality of interface elements may be placed in communication with a separate controller such that each interface element is independently controlled by its respective controller.

[0091] In various alternative embodiments, certain aspects of the method may be performed in the surgical field of a neck incision and may be visually monitored intraoperatively, monitored intraoperatively by neural monitoring, monitored intraoperatively by monitoring of electromyographical signals, and/or performed endoscopically. Navigation of the interface element(s) and/or other implements may be performed using palpation, x-ray, CT, MRI, electrical test stimulators, a schablone manufactured according to general or the specific computer tomography data of the subject, a mask of the throat and mandible, and/or by use of a 2 or more dimensional video navigation system in relation to at least one of computer tomography, X-ray, MRI, and ultrasound data of the subject. Various elements may be repositioned, for example, with a different angle, a different direction, or a different starting point.

[0092] In various alternative embodiments, at least one laryngeal structure (e.g., a single vocal cord, both vocal cords, the epiglottis, or a pharyngeal constrictor) may be interfaced using the interface element(s), and the interface element(s) may be positioned for interfacing with a muscle, nerve, or receptor. Such interfacing may include, among other things stimulating a laryngeal structure, activating a laryngeal structure, blocking a laryngeal structure, inhibiting operation of a laryngeal structure, moving a laryngeal structure, removing a portion of a laryngeal structure, repairing a laryngeal structure, delivering a material to a laryngeal structure, or monitoring a laryngeal structure. Moving a laryngeal structure may include opening, closing, or varying tension of the laryngeal structure. The interfacing may include receiving and/or recording electromyographic signals of a related muscle and/or may include receiving and/or recording electroneurographic signals of a related nerve. In various alternative embodiments, various types of stimuli (e.g., electrical energy or drugs) may be delivered to a laryngeal structure via the interface element(s).

[0093] In certain embodiments, the interface element may include an electrode, in which case a portion of the electrode may be routed percutaneously through the skin to the outside of the subject and connected to an external stimulator for a certain duration to verify efficacy of the interfacing with laryngeal structures. In other embodiments, the interface element may include a sensor, in which case a portion of the sensor may be routed percutaneously through the skin to the outside of the subject and connected to an external recorder for a certain duration to verify efficacy of the interfacing with laryngeal structures. In yet other embodiments, the interface element may include a catheter, in which case a portion of the catheter may be routed percutaneously through the skin to the outside of the subject and connected to an external pump for a certain duration to verify efficacy of the interfacing with laryngeal structures. In some embodiments, the certain duration may be from 1 to 60 minutes. In other embodiments, the certain duration may be from 1 to 24 hours. In yet other embodiments, the certain duration may be from 1 to 7 days. In still other embodiments, the certain duration may be from 1 to 20 weeks. An interface element (e.g., an electrode, sensor, or catheter) may be permanently connected to a surgically implanted controller (e.g., a stimulator, recording device, or pump) in the case efficacy is proven or may be removed from the subject in the case efficacy has not been proven.

[0094] In accordance with another aspect of the invention there is provided a system for positioning at least one interface element for interfacing with laryngeal structures in a subject comprising a hollow needle having an inner area for the at least one interface element

to be inserted through the hollow needle, the hollow needle having a curve that allows the hollow needle to curve around cartilage.

[0095] In accordance with another aspect of the invention there is provided a system for positioning at least one interface element for interfacing with laryngeal structures in a subject comprising a needle having connected thereto a thread for connection with the at least one interface element to allow for retraction of the needle and the at least one interface element together, the needle having a curve that allows the needle to curve around cartilage.

[0096] In accordance with another aspect of the invention there is provided a method of employing an interface element in a subject in order to facilitate interfacing with vocal cords such as for diagnosis or treatment of a laryngeal impairment. The method involves inserting a needle into a subperichondral space beneath posterior cricoarytenoid muscle, the needle being curved and hollow; pushing the needle around cartilage so that the needle is accessible externally from the subject; inserting an interface element through the curved hollow needle; and retracting the curved hollow needle into a larynx while placing the interface element in a desired position.

[0097] In various alternative embodiments, the curved hollow needle may include a thread, in which case the method may further involve inserting the thread into the subperichondral space beneath the posterior cricoarytenoid muscle and cartilage from a back side of the larynx. Pushing the needle may include pushing the needle until the needle is seen from outside of the subject, making the needle leave the subject through skin, and/or forcing the needle to appear through an opening of the subject's body by a surgery.

[0098] In accordance with another aspect of the invention there is provided a system for inserting an interface element into a subperichondral space beneath posterior cricoarytenoid muscle in order to facilitate interfacing with vocal cords in a subject, the system comprising a needle having a hollow inner area adapted so that the interface element can be inserted through the needle, the needle having a curve that allows the needle to move around cartilage so that the hollow needle is seen from outside of a body of the subject.

[0099] In various alternative embodiments, the needle may be inserted into the subperichondral space beneath the posterior cricoarytenoid muscle and into cartilage from a back side of a larynx. The system may further include the interface element. The interface element may include an electrical stimulation electrode, an electrical recording electrode, a catheter to transport liquids, or a catheter for release of drugs. The hollow needle may be adapted to be inserted endoscopically. The hollow needle seen from outside of the body may appear through an opening of the subject's body by a surgery.

BRIEF DESCRIPTION OF THE DRAWINGS

[00100] The foregoing features of the invention will be more readily understood by reference to the following detailed description, taken with reference to the accompanying drawings, in which:

[00101] FIG. 1 shows a horizontal cut through the larynx and an insertion path for inserting an interface element into a space between PCA muscle and cricoid cartilage plate according to illustrative embodiments of the present invention;

[00102] FIG. 2 shows a lateral view of the larynx and an insertion path for inserting an interface element into the space between the PCA muscle and the cricoid cartilage plate according to illustrative embodiments of the present invention;

[00103] FIG. 3 shows a horizontal cut through the larynx and an insertion path for inserting an interface element into a subperichondral tunnel according to illustrative embodiments of the present invention;

[00104] FIG. 4 shows a lateral view of the larynx and the insertion path for an interface element inserted into the subperichondral tunnel according to illustrative embodiments of the present invention;

[00105] FIG. 5 shows a horizontal cut through the larynx and an insertion path for inserting an interface element into a drill hole through cricoid cartilage according to illustrative embodiments of the present invention;

[00106] FIG. 6 shows a lateral view of the larynx and the insertion path for inserting an interface element into a drill hole through the cricoid cartilage according to illustrative embodiments of the present invention;

[00107] FIG. 7 shows a horizontal cut through the larynx and an insertion path for inserting an interface element into a subperichondral tunnel on an inside of thyroid cartilage lamina according to illustrative embodiments of the present invention;

[00108] FIG. 8 shows a lateral view of the larynx and an insertion path for inserting an interface element into the subperichondral tunnel on the inside of the thyroid cartilage lamina according to illustrative embodiments of the present invention;

[00109] FIG. 9 shows a front view of the larynx and the tuberculum thyroideum caudale as a landmark of the starting point of the insertion according to illustrative embodiments of the invention;

[00110] FIG. 10 shows a 3-dimensional computer tomography reconstruction of the vocal cord that includes the tuberculum thyroideum caudale according to illustrative embodiments of the invention;

[00111] FIG. 11 shows a lateral view of a 3-dimensional computer tomography reconstruction of the vocal cord and the insertion path for inserting an interface element into an insertion route through the cricoid cartilage according to illustrative embodiments of the present invention;

[00112] FIG. 12 shows a 3-dimensional computer tomography reconstruction of the vocal cord from below illustrating the cricoids cartilage arch thickness towards the cricoids cartilage plate according to illustrative embodiments of the invention;

[00113] FIG. 13 shows a 3-dimensional computer tomography reconstruction of the vocal cord from behind illustrating the exit point of the insertion route through the crycoid cartilage appearing under the posterior cricoarytenoid muscle according to illustrative embodiments of the invention;

[00114] FIG. 14 shows a 3-dimensional computer tomography model of the vocal cord photographed from below illustrating that the cricoid cartilage arch thickens towards the cricoid cartilage plate according to illustrative embodiments of the invention;

[00115] FIG. 15 shows a 3-dimensional computer tomography model of the vocal cord photographed from behind according to illustrative embodiments of the invention;

[00116] FIGS. 16A-M show an interface element insertion system having a curved needle system and an insertion path between muscle and cartilage according to illustrative embodiments of the present invention;

[00117] FIGS. 17A-H show a lateral view of the larynx and the insertion path of an interface element between muscle and cartilage according to illustrative embodiments of the present invention; and

[00118] FIG. 18 shows a lateral view of the larynx and an insertion path for inserting an interface element between muscle and cartilage according to illustrative embodiments of the present invention.

DESCRIPTION OF ILLUSTRATIVE EMBODIMENTS

[00119] Definitions. As used in this description and the accompanying claims, the following terms shall have the meanings indicated, unless the context otherwise requires:

[00120] A “subject” may be a human or animal.

[00121] An “interface element” is an element for directly or indirectly interfacing with the laryngeal structures of a subject and may include, but is in no way limited to, an electrode (e.g., for conveying electrical signals to and/or from an anatomical structure such as for stimulating, sensing, recording, etc.), a sensor (e.g., for monitoring an anatomical structure), a catheter (e.g., for conveying a fluid or other material to and/or from an anatomical structure), a delivery device (e.g., a pump or syringe for delivering a medication, drug, nutrient, fluid, or other material to an anatomical structure), a heat delivery device (e.g., a cauterization tool), a cold delivery device (e.g., a cryogenic tool), a surgical device (e.g., a scalpel or biopsy tool for removing tissue, a suturing device for repairing tissue, or other implement used in surgical procedures), a needle, a probe (e.g., for physical manipulation or stimulation of an anatomical structure), a light transmission device (e.g., a laser, optical fiber, scope, camera, light), a tissue, a bulking material, or other thing that can be delivered for interfacing with the laryngeal structures (e.g., light, heat, cold, fluid, drug, medicine, nutrient, radiation, or other material), to name but a few. An interface element may be used in conjunction with an integral or separate controller, such as a stimulation device (e.g., a pacer), a sensing device (e.g., a monitor), a recording device, and/or a manipulation device (e.g., a handle), to name but a few. In some cases, such a controller may be portable, wearable, and/or implantable. In some cases, such a controller may be capable of operating multiple interface elements either in unison or independently, e.g., for performing different functions on different laryngeal structures or for redundancy in case of a failure of an interface element or a component of the controller. In some cases, such a controller may be directly connected to an interface element (e.g., via a wire) or may interact with an interface element remotely (e.g., via a wireless communication interface). Thus, in various embodiments, multiple interface elements may be used with separate controllers, or multiple interface elements may be used with a single controller, and the interface elements may interact with the controller(s) in the same way or in different ways.

[00122] A “laryngeal structure” is a structure associated with the larynx, including, but not limited to, a single vocal cord, both vocal cords, the epiglottis, a pharyngeal constrictor, a supraglottic sphincter, or related structures (e.g., tissue, muscle, nerve, bone, cartilage), to name but a few.

[00123] In the context of the laryngeal structures of a subject, “unilaterally” means that an interface element is placed on one side of the body, vocal cord, or other structure (i.e., typically either the left side or the right side), and “bilaterally” means that an

interface element is placed on each side of the body, vocal cord, or structure (i.e., typically both the left side and the right side). A “wing” is a part or aspect of the laryngeal structure.

[00124] A "needle" is an implement for forming a tunnel or for otherwise directly or indirectly positioning an interface element and may include, but is in no way limited to, a needle, a raspatorium, or a drill, to name but a few. In various embodiments, a needle may be solid or hollow, may be straight or bent in one or more places, and/or may be of fixed length or variable length (e.g., by telescoping).

[00125] A "thread" is used for directly or indirectly positioning an interface element and may include, but is in no way limited to, a thread, string, rope, chain, fiber, wire, filament, or tether, to name but a few.

[00126] "Repositioning" of a needle, interface element, or other thing and "re-generating" a tunnel may include changing the angle, direction, and/or starting point.

[00127] In certain contexts, terms such as "introducing," "positioning," "placing," and "inserting" may be used to refer to the same or similar operations, particularly with regard to forming a tunnel, inserting a thread, and/or positioning an interface element.

[00128] Embodiments of the present invention include endoscopically controlled, minimally invasive positioning of an interface element. The placement system and method reduce the risks related to a surgical procedure and at the same time allows an adjustment of stimulation to a laryngeal structure of the subject in vocalization, breathing or swallowing by alternatively stimulating opening, closing or elevation of the larynx. In addition, embodiments may allow more than one interface element to be inserted (e.g., bilaterally, or separate elements for opening and closing or larynx elevation). “Pull through” techniques may require special reinforcements of the interface element to accommodate traction stress. Pushing in the interface element under endoscopic view is an especially gentle method. Subperichondral or intra-chondral routing of the interface element may give better mechanical protection and electrical stimulation through the perichondrium, which may protect against corrosion of the interface element. Intra-operative endoscopic control and stimulation ensure optimal positioning of the interface element. Stimulation of opening and closing encourages a better preservation of movability of the crico-arytenoid joint and offers a better dynamic range potentially resulting in better exercise abilities and better speech quality in subjects than subjects without the stimulation. Bilateral interface element placement also offers the advantage of new three-dimensional electric dipole vectors for optimal stimulation, which may further improve the flexibility. Bilateral, separately controlled interface elements may also provide a higher safety in case of device failure. For

example, if one side fails, the other side may (partially) compensate until the subject seeks clinical help.

[00129] Various exemplary embodiments are described with reference to the insertion of an electrode for facilitating the movement or stimulation of vocal cords. Other types of interface elements, however, may be used, in addition to, or lieu of, to facilitate interfacing with laryngeal structures generally according to various embodiments of the present invention.

[00130] In order to decrease current spread, the placement of electrodes preferably localizes current to a related anatomical structure (e.g., target muscle or nerve) as much as possible by a minimally invasive surgery. A needle insertion technique, instead of an open surgery, may provide the solution. In one embodiment, the capability of reaching a location or target (e.g., inside a subject's body) is provided by insertion of a curved needle system capable of going around corners, around obstacles and/or cartilage. In another embodiment, a straight path or tunnel may be used to reach the target or location.

[00131] Embodiments of the present invention also permit a minimally invasive, two stage implantation procedure to be possible. First, the interface element is inserted and a test stimulation session may be conducted over time, e.g., over several days or weeks, to show efficiency of the system. Then, when efficiency is positively verified a stimulator may also be implanted or when efficiency is not positively verified the interface element may be retracted out of the body without a complicated surgery.

[00132] Embodiments of the present invention are directed to the implantation of an interface element in the larynx using minimally invasive techniques. One embodiment includes straight tubular interface elements (e.g., electrodes) that may be used by inserting the elements in a "pull back" procedure after the interface element is attached to a thread that has been previously inserted along an insertion path.

[00133] FIG. 1 shows a horizontal cut through the larynx in the plane of the arytenoid cartilages. The projected way of the thread for inserting the interface element according to one specific embodiment is marked with a bold black interrupted line, insertion path **106**. The discussion below explains how the interface element may be brought in the space between the PCA muscle **108** and the cricoid cartilage plate **110**. In addition, the vicinity to the recurrent laryngeal nerve **107** and its medial branch is shown. FIG. 2 shows a lateral view of the larynx to illustrate how the thread for the pull back procedure may be directed ventrally below the larynx.

[00134] Under direct endoscopic laryngoscopic view, a slightly curved needle may be inserted into the backside of the larynx, called the postcricoidal region. The needle is inserted above the posterior cricoarytaenoid (PCA) muscle **108**, which originates from the cricoid cartilage plate **110** and inserts at the arytenoid cartilage **104**. The cricoid cartilage **115** includes a cricoid cartilage arch **103** and the cricoid cartilage plate **110**, with the bottom of the cricoid cartilage **115** being the part on the anterior side of the vocal cord, the top of the cricoid cartilage **115** being the part on the posterior side of the vocal cord, and the two lateral parts or wings being on the left and on the right of the vocal cord. The PCA muscle **108** is the main and only opening muscle of the vocal cords **102**. A branch of the recurrent laryngeal nerve **107** runs beneath it on the surface of the cricoid cartilage plate **110** from inferior lateral to superior medial. This nerve branch supplies the PCA muscle **108** with motor nerve fibers. The needle may be pushed laterally and downwardly towards the cricothyroid joint **105** in the subperichondral space on the posterior side of the cricoid cartilage plate **110**. A tunnel may be preformed, e.g., with a raspatorium, in order to make this insertion easier. The needle may then be pushed out of the larynx in a more forward direction into the neck soft tissue. Attention should be paid to not penetrate the piriform sinus of the hypopharynx **109**. Tracheal cartilage **201** is shown in FIG. 2 as a reference point.

[00135] The needle is thus held in the neck soft tissue. This is achieved through a small external surgical approach. The skin may be incised a few centimeters longitudinally or horizontally and laterally near the lower end of the larynx. The tissue between the larynx and the neck vessel sheath may be separated to create a space to find the needle and to protect the big neck vessels. In some cases, it may be helpful to rotate the larynx a little to the opposite side. Once the needle has been found, it is caught. A thread is fixed (e.g., knotted or by other connecting means) to the interface element tip and the needle. The needle is pulled back with the interface element connected to it by the thread. The interface element is then pulled in place. The interface element should be strong enough to withstand the traction forces. The position of the interface element may be corrected or optimized by visually controlling the movement of the vocal cord **102** in response to stimulation, such as electrical stimulation. Once the best position has been established the interface element may be fixed with a suture to the side of the cricoid cartilage **115** or by other means. After a final control of electrical response, the thread may be cut at the surface of the mucous membrane on the back side of the larynx. The little pieces of thread that may be left at the electrode tip subsequently dissolve by themselves. A pacemaker housing may then be implanted via a small subcutaneous tunnel into a subcutaneous pocket, e.g., on the chest wall.

A second incision on the chest wall to affix the pacer housing may be necessary. The incisions are closed with sutures or clips as well known to those skilled in the art. Enough time for wound healing is allowed before the device is used.

[00136] Alternatively, the needle may be pushed in a more downward direction so that it enters the neck in the space between the trachea and the esophagus. The advantages of this method are: 1) less tissue damage to the larynx and its connective tissue gliding space which is important for a good larynx elevation (during swallowing and speaking with different tone pitches), 2) the electrode tip is laying close to the cartilage surface which protects it from mechanical forces, 3) the electrode tip runs along the expected location of the nerve branches supplying the posterior arytenoid muscle, and 4) more laterally, the nerve stem or other branches of the recurrent laryngeal nerve come close to the multi-electrode so that the electrode may be used for opening and closing the vocal cord.

[00137] One embodiment may be an interface element inserted into a subperichondral tunnel on the outside of the cricoid cartilage arch **103**, through a tunnel through the cricoid cartilage arch **103** to the posterior subperichondral space of the cricoid cartilage plate **110**, or with the help of a needle through the cricoid cartilage **115** to the posterior subperichondral space of the cricoid cartilage plate **110**. FIG. 3 shows an interface element inserted into a subperichondral tunnel, insertion path **301** and FIG. 11 (to be described in more detail below) shows an interface element inserted through the cricoid cartilage **115**. As shown, the tip of the electrode reaches behind the cricothyroid joint **105** where the recurrent laryngeal nerve **107** divides into its branches. FIG. 4 shows a lateral view of the electrode inserted into the subperichondral tunnel.

[00138] Similarly, FIGS. 5 and 6 show an interface element inserted into a tunnel through the cricoid cartilage **115**. The tunnel may be straight or bent according to the technology used to generate the tunnel. It may be possible to reach the recurrent laryngeal nerve **107** more medially and therefore better stimulate the opening movement of the vocal cord **102**. The skin may be incised a few centimeters longitudinally or horizontally and laterally near the lower end of the larynx where the cricoid cartilage **115** is or the skin may not even be incised and the needle is directly pushed through the skin.

[00139] After dissection of subcutaneous tissue the prelaryngeal “strap muscles” have to be moved medially or laterally. The upper end of the thyroid gland often covers the cricoid cartilage arch **103**. It is dissected from the cartilage to expose the cricoid cartilage arch **103**. This is usually easily achieved, but care should be taken not to damage any nerve structures. In some cases, a vessel may have to be tied. Once the cricoid cartilage

arch **103** with anterior thyrocricoid muscle sitting on it is exposed, the larynx is slightly turned to the opposite site. The perichondrium of the cricoid cartilage **115** is incised. A subperichondral tunnel may be formed with a small curved raspatorium. The tunnel may be progressed towards the cricothyroid joint **105** and extended a little further either above or below it. The cricothyroid joint **105** may be identified by palpation or by other means.

[00140] The stimulating electrode may be inserted into this tunnel. This may be achieved with an electrode which is stiff enough by itself or which is otherwise stabilized. Small hooks and/or a miniature endoscope like in sialography (endoscopic examination of saliva ducts) or a tube that may be split and fits the electrode in its lumen may be used to aid insertion. The correct positioning of the electrode may be controlled by laryngoscopic control of vocal cord movements. Once the best position has been established the electrode may be fixed with a suture, silicone anchors or another kind of fixation to the side of the cricoid cartilage **115**. Small tags on the electrode lead may be used to achieve a good fixation.

[00141] A pacemaker may then be implanted via a small subcutaneous tunnel into a subcutaneous pocket, e.g., on the chest wall. A second incision on the chest wall to affix the pacemaker may be necessary. The incisions are closed with sutures or clips as well known to those skilled in the art. Enough time for wound healing is allowed before the device is used.

[00142] Alternatively, the interface element may be routed through a tunnel (e.g., in the form of a drill hole) through the arch of the cricoid cartilage **103** itself towards the backside of the cricoid cartilage plate **110**. This would allow a lightly more medial position of the electrode tip and make it easier to stimulate the nerve branches to the PCA muscle **108**. For example, an electrode may be inside a needle during an insertion, fixed inside the needle and then pushed out or held in place while the needle is pulled back, or the tip may be bent around the edges of the tip of the needle like a “hooked-wire” electrode and, thus, is self-fixing when pulling the needle back, or the electrode may not be inside the needle during insertion but pulled inside after the needle has been placed and then pushed out or held in place while the needle is pulled back. The advantages of this embodiment are: 1) reduced tissue damage to the larynx and its connective tissue gliding space which is important for a good larynx elevation (during swallowing and speaking with different tone pitches) and 2) the electrode tip is laying close to the cartilage surface or inside the cartilage which protects it from mechanical forces.

[00143] The navigation for the insertion path or route may be done by the help of landmarks only, or by the assistance of a template manufactured according to general or the specific computer tomography data of the subject, or by the assistance of a mask of throat and mandible comparable to radiation masks, or with a three or more dimensional video navigation system in relation to the computer tomography, X-ray, MRI or ultrasound data of the subject. When the needle is pushed through the cartilage and exits on the backside of the cartilage or the electrode is inside the needle with the tip of the electrode extending slightly beyond the needle tip, the needle may then be connected to an electrical stimulation apparatus to verify the position of the needle tip by the effectiveness of the vocal cord opening evoked by the electrical stimulation. The needle may be insulated in selected areas (e.g., insulated except for the tip) or may not be insulated at all. If the effectiveness of the vocal cord opening is not satisfactory, the needle may be pulled back and pushed through the cartilage again at another angle till the needle leaves the cartilage on the other side and is pushed out in a certain position between posterior cricoarytenoid muscle and cricoid cartilage. The process of verifying the position of the needle tip may then be repeated. For example, the needle or the electrode inside the needle with the tip of the electrode extending slightly beyond the needle tip may then be connected to an electrical stimulation apparatus to verify the position of the needle tip by the effectiveness of the vocal cord opening evoked by the electrical stimulation and so on.

[00144] One embodiment may use straight tubular electrodes inserted into a tunnel on the inside of the thyroid cartilage. FIG. 7 shows an electrode insertion into a subperichondral tunnel on the inside of the thyroid cartilage lamina, insertion path **701**. FIG. 8 shows the lateral view. As shown in FIGS. 7 and 8, the tunnel declines a little to reach the dividing region of the recurrent laryngeal nerve **107**. It may not be necessary in all cases to have the electrode reach as far as the dividing point of the recurrent laryngeal nerve **107**.

[00145] A small, preferably horizontal, prelaryngeal skin incision in the neck may be made. The thyroid cartilage **101** may be exposed in the anterior part. A tunnel may be made (e.g., by drilling a hole) preferably half way between the superior and inferior thyroid incisures (which is about the height of the glottic plane) in the anterior third of the cartilage. The tunnel may be large enough to enter with a small raspatorium, a curved needle (e.g., a curved needle system or a telescopic curved needle system), or some other tool to create a subperichondral tunnel at the inside of the thyroid cartilage **101**. The tunnel may be made slightly downwards in the direction of the cricothyroid joint **105**. It extends either above or below the joint into the region of the recurrent laryngeal nerve **107** and its dividing

point. Finding the way towards the recurrent laryngeal nerve **107** near the cricothyroid joint **105** may be navigated by palpation, x-ray, CT/MRI-navigation or the use of electrical test stimulators. In some cases, the tunnel may not progress as far as the joint region if only the anterior branch is stimulated (for adduction of the vocal cord).

[00146] Into this tunnel, the stimulating electrode may be inserted. This may be achieved with an electrode which is stiff enough by itself or has been otherwise stabilized. Small hooks and/or a miniature endoscope like in sialography (endoscopic examination of saliva ducts) or a tube that may be split and fits the electrode in its lumen may be used to aid insertion. The correct positioning of the electrode may be controlled by visual control of larynx movements. Once the desired position has been established the electrode may be fixed near the tunnel with a suture or by other means. A pacemaker may then be implanted via a small subcutaneous tunnel into a subcutaneous pocket, e.g., on the chest wall. A second incision on the chest wall to affix the pacemaker may be necessary. The incisions may be closed with sutures or clips as well known to those skilled in the art. Enough time for wound healing is allowed before the device is used. Alternatively, or in addition, the insertion path or a second insertion path may be advanced more cranially. An electrode may be placed there to stimulate the supraglottic sphincters (muscles closing the larynx entrance, protection against food/foreign body aspiration). Different electrodes may be inserted for the vocal cord(s) and for the supraglottic sphincters.

[00147] The advantages of this embodiment are: 1) reduced tissue damage to the larynx and its connective tissue gliding space which is important for a good larynx elevation (during swallowing and speaking with different tone pitches). 2) the electrode tip is laying close to the cartilage surface beneath the perichondrium which may protect it from mechanical forces. The perichondrium is conductive for electrical currents and probably prevents a sheathing of the electrode with excessive connective tissue which “insulates” the electrode (e.g., increasing the electrical resistance and therefore the energy drain from the stimulation device to maintain a constant stimulus effect). Also, corrosion of the electrode may be reduced. 3) multiple electrodes may reach the nerve branches to the internal thyroarytenoid muscle or the muscle itself and at its tip the branching point of the recurrent laryngeal nerve. The electrode may, therefore, stimulate closing of the glottic gap, and enhancing the tension of the vocal cord as well as opening the glottic gap by stimulating the nerve branches to the posterior cricoarytenoid muscle.

[00148] Another embodiment may use a straight insertion path or tunnel for inserting an interface element into an insertion route through the cricoid cartilage. As shown

in FIG. 9, the starting point of the insertion path **903** may be near the tuberculum thyroideum caudale **901**, which may be used as a landmark. The insertion point may start about a few millimeters in front or about up to 2 cm backward. Due to the varying thickness of the cricoid cartilage **115**, the height may not be varied substantially in various embodiments.

[00149] FIG. 10 shows a front perspective view and FIG. 11 shows a lateral view of a 3-dimensional computer tomography reconstruction of the vocal cord that includes the tuberculum thyroideum caudale **901**, which is marked by an arrow. FIG. 12 shows a 3-dimensional computer tomography reconstruction of the vocal cord from below illustrating the cricoid cartilage arch **103** thickness towards the cricoid cartilage plate **110**. Because the lateral walls of cricoid cartilage **115** are thickened at a particular height, it is possible to reach almost midline even with a straight insertion route by beginning the insertion near or at the tuberculum thyroideum caudale **901**. One insertion path may include a straight tunnel **1201** and another insertion path may include a saggital tunnel **1103** (also marked with an asterick), which ends about below the recurrent laryngeal nerve (RLN). Thus, a needle may be inserted in a straight line through one or both of the lateral walls of the cricoid cartilage **115** in a direction to reach the nerve branches of the recurrent laryngeal nerve **107** which innervate the PCA muscle **108**. At other heights of the cricoid cartilage **115** (with less thickness), an angled or curved insertion route may be used along the inner and outer borders of the lateral walls of the cricoid cartilage **115** to stay inside the walls. Therefore, the route of the needle may start to enter the cricoid cartilage **115** right after passing through the skin and may stay inside the lateral wall till the needle leaves the backside of the cricoid cartilage **115** directly near a branch of the recurrent laryngeal nerve **107** innervating the PCA muscle **108**.

[00150] FIG. 13 shows a 3-dimensional computer tomography reconstruction of the vocal cord from behind illustrating the exit point **1301** and **1303** of the insertion route through the crycoid cartilage **103**, **110** appearing under the PCA muscle **108**. Exit point **1301** shows where the straight tunnel **1201** (shown in FIG. 12) exits and exit point **1303** shows where the saggital tunnel **1203** (shown in FIG. 12) exits. FIG. 14 shows a 3-dimensional computer tomography model of the vocal cord photographed from below illustrating that the cricoid cartilage arch thickens towards the cricoid cartilage plate. Due to the thickness, it is possible to reach almost midline **1401** with a straight tunnel **1403** or a saggital tunnel **1405** ending about below the recurrent laryngeal nerve (RLN). FIG. 15 shows a 3-dimensional computer tomography model of the vocal cord photographed from behind. As shown, the midline **1501**, the medial direction **1503** of a tunnel, and the lateral direction **1505** of a tunnel are marked with white dotted lines.

[00151] FIG. 18 shows a lateral view of the larynx and an insertion path or tunnel for inserting an interface element **1803** between muscle and cartilage. The interface element **1803** may be connected to a pacemaker or stimulator **1806**, which may be implanted via a small subcutaneous tunnel into a subcutaneous pocket on the subject.

[00152] Embodiments of the present invention may also include an insertion system comprising a telescopic curved needle system for inserting an interface element in a subject. The telescopic curved needle system includes one or more inner hollow needles having successively smaller diameters than the outer portion of the telescopic curved needle system and located inside of the outer portion. FIGS. 16A-16M show the telescopic curved needle system at various stages during an insertion procedure. At the beginning of the procedure, the telescopic curved needle system may initially be relatively straight when in its unexpanded form as shown in FIG. 16A. The telescopic curved needle system may be inserted from outside of the body through a small incision in the skin or by starting from cavities inside the body like the pharynx, the stomach, the colon and the like. The relatively straight telescopic curved needle system may then be pushed forward in a pre-planned angle or under the control of a navigation tool (e.g., by palpation, x-ray, CT, MRI-navigation or the use of electrical test stimulators) with a certain force or speed until a certain length of the telescopic curved needle system is inserted, or a landmark, e.g., a bone, a cartilage and the like, is reached, or a target shown by the navigation tool is reached. For example, under direct or endoscopic laryngoscopic view, the relatively straight, unexpanded telescopic curved needle system may be inserted into the backside of the larynx so that it is pushed in-between the PCA muscle and the cricoid cartilage.

[00153] The first inner hollow needle **1603**, which is totally hidden inside the outer portion of the telescopic curved needle system and has a smaller diameter than the outer portion, may then be pushed out of the tip of the outer hollow needle **1604**, which may stay in place. The first inner hollow needle **1603** may be pushed with a certain force or speed until a certain length of the telescopic curved needle system is inserted, or a landmark, e.g., a bone, a cartilage and the like, is reached, or a target shown by the navigation tool is reached. For example, after inserting the relatively straight, unexpanded telescopic curved needle system deep enough to be outside the space in-between the muscle **1602** and the cartilage **1601** (on the other side of the muscle than the insertion point was) and to reach the lower posterior lateral edge of the cricoid cartilage near the crico-thyroid joint, the first inner hollow needle **1603** may be pushed out of the tip of the outer portion of the telescopic curved needle system with a certain force or speed until the first inner hollow needle **1603** reaches a desired

position, e.g., leaves the body through the skin without hurting any important structure on its way through the tissue.

[00154] The telescopic curved needle system may not need to be further extended if a desired length or target is reached. However, if one extension or edge of the telescopic curved needle system is not enough to reach the target, then a second inner hollow needle **1605**, which is inside the first inner hollow needle and has a smaller diameter than the first inner hollow needle, may be pushed out of the tip of the first inner hollow needle **1603**, which may stay in place. The second inner hollow needle **1605** may be pushed with a certain force or speed until a certain length of the telescopic curved needle system is inserted, or a landmark, e.g., a bone, a cartilage and the like, is reached, or a target shown by the navigation tool is reached.

[00155] For example, if a second extension or edge is preferred after the edge near the cricoid joint then a second inner hollow needle **1605** may be used and pushed out of the tip of the first inner hollow needle **1603** with a certain force or speed until the second inner hollow needle **1605** reaches a desired position, e.g., leaves the body through the skin without hurting any important structure on its way through the tissue. The telescopic curved needle system may include additional inner needles if necessary.

[00156] After the inner hollow needle **1603** or **1605** leaves the body through the skin, an electrical stimulation electrode **1606**, e.g., with contacts in a row along the tip of the electrode **1606**, may be inserted inside the whole electrode insertion system of hollow needles. The electrode **1606** may be inserted until the electrode's tip is positioned in a desired location, e.g., in-between the PCA muscle **1602** and the cricoid cartilage **1601**, or even further to the insertion point of the curved needle system (it may even look outside the skin in the larynx). The curved needle system may then be retracted back into the laryngeal side of original needle insertion while keeping the electrode **1606** in position, e.g., by fixing it at the insertion point of the electrode **1606**, for example, manually. Alternatively, the curved needle system may be retracted while placing the electrode **1606** in a desired position. When the curved needle system is totally extracted and the electrode **1606** is in its desired positioned, e.g., on its way in-between the posterior cricoid muscle **1602** and the cricoid cartilage **1601**, electrical energy may be transmitted through the electrode **1606**. The electrical energy may be transmitted sequentially over one after the other electrical contact pads near the tip of the electrode **1606**. The position of the electrode **1606** may then be corrected or optimized by visually controlling the movement of the vocal cord in response to electrical stimulation and retracting the electrode **1606**, if necessary. Alternatively, electrical

energy may be transmitted through the electrode **1606** before the curved needle system is totally extracted, thus allowing optimization of the electrode **1606** position both by retracting and/or inserting the electrode **1606**.

[00157] A stimulation device **1806**, such as a pacemaker (see FIG. 18) may then be implanted via a small subcutaneous tunnel into a subcutaneous pocket. The insertion system including a telescopic curved needle system may be used in a variety of ways and applications, e.g., inserting an interface element as shown in FIGS. 1-8.

[00158] Embodiments of the present invention may include an insertion system comprising a straight needle system or a curved needle system for inserting an interface element in a subject. FIGS. 17A-H show a curved needle system at various stages during an insertion procedure. As shown, the procedure begins by inserting the curved needle system **1703** from outside of the body through a small incision in the skin or by starting from cavities inside the body like the pharynx, the stomach, the colon and the like. The curved needle system **1703** may then be pushed forward in a pre-planned angle or under the control of a navigation tool or via the help of landmarks (e.g., a bone, a cartilage and the like) with a certain force or speed until a certain length of the curved needle system is inserted, the landmark is reached, or a target shown by the navigation tool is reached. The navigation tool may include palpation, x-ray, CT or MRI navigation or the use of electrical test stimulators connected to the interface element **1704**. For example, the stimulator may emit electrical energy via one or more contacts positioned at the tip of the interface element **1704**, at selected areas along the interface element **1704** (e.g., at non-insulated areas when the element includes insulated and non-insulated areas) or along the whole interface element **1704** (e.g., when the element is not insulated).

[00159] Under direct or endoscopic laryngoscopic view, the curved needle system may be inserted into the backside of the larynx so that it is pushed in-between the PCA muscle **1702** and the cricoid cartilage **1701**. After inserting the curved needle system **1703** deep enough to be outside the space in-between the muscle **1702** and the cartilage **1701** (on the other side of the muscle than the insertion point was) and to reach the lower posterior lateral edge of the cricoid cartilage near the crico-thyroid joint, the curved needle system **1703** may turn around this edge of the cartilage **1701** because of its pre-curved shape. The curved needle system **1703** may be pushed further until it reaches a desired position, e.g., leaves the body through the skin without hurting any important structure on its way through the tissue.

[00160] After the curved needle system **1703** leaves the body through the skin, an interface element **1704** such as an electrical stimulation electrode (e.g., with contacts in a row along the tip of the electrode) or a catheter, may be inserted inside the curved needle system. In another embodiment, an interface element **1704** is fixed to the tip of the curved needle system **1703** by a thread and the interface element **1704** is inserted from the outside by pulling the curved needle system **1703** back and thereby pulling the interface element **1704** back through the tissue via the connected thread. The interface element **1704** may be inserted until the element's tip is positioned in a desired location, e.g., in-between the PCA muscle **1702** and the cricoid cartilage **1701**, or even further to the insertion point of the curved needle system **1703** (it may even look outside the skin in the larynx). The curved needle system **1703** may then be retracted back into the laryngeal side of original needle insertion while keeping the interface element **1704** in position, e.g., by fixing it at the insertion point of the interface element **1704**, for example, manually. Alternatively, the curved needle system **1703** may be retracted while placing the interface element **1704** in a desired position. When the curved needle system **1703** is totally extracted and the interface element **1704** is in its desired position, e.g., on its way in-between the PCA muscle **1702** and the cricoid cartilage **1701**, an item may be transmitted through the interface element **1704**, such as electrical energy through an electrode or a drug through a catheter. Electrical energy may be transmitted sequentially over one after the other electrical contact pads near the tip of the electrode. The position of the interface element **1704** may then be corrected or optimized by visually controlling the movement of the vocal cord in response to the transmitted item (e.g., electrical stimulation) interacting with the vocal cord, and retracting the interface element **1704**, if necessary. Alternatively, the item may be transmitted through the interface element **1704** before the curved needle system **1703** is completely extracted, thus allowing optimization of the interface element **1704** position both by retracting and/or inserting the interface element **1704**, if necessary.

[00161] The pacer **1806** may then be implanted via a small subcutaneous tunnel into a subcutaneous pocket. Embodiments of the present invention also permit a minimally invasive, two stage implantation procedure to be possible. First, an interface element **1704**, e.g., an electrode, may be inserted as disclosed above, but the stimulator itself is not implanted during the same surgery but left outside the body. A test stimulation session may then be performed over time, e.g., several days or even weeks. If this test stimulation period shows efficiency, the pacer may be sterilized, the electrodes may be connected to the pacer **1806** via a small subcutaneous tunnel, and the pacer may then be implanted into the

subcutaneous pocket. If the test stimulation period shows not enough efficiency, then the electrode may be retracted out of the body without a complicated surgery by simply pulling the electrode back till its tip leaves the skin. The insertion system including a curved needle system **1703** may be used in a variety of ways, e.g., inserting an interface element **1704** as shown in FIGS. 1-8 and FIG. 18.

[00162] Although various exemplary embodiments of the invention have been disclosed, it should be apparent to those skilled in the art that various changes and modifications may be made which will achieve some of the advantages of the invention without departing from the true scope of the invention.

What is claimed is:

1. A method of positioning interface elements for interfacing with laryngeal structures of a subject such as for diagnosis or treatment of a laryngeal impairment, the method comprising:
 - positioning a needle in geographical relation to the lateral wing of a vocal cord cartilage;
 - positioning at least one interface element via the needle.
2. A method according to claim 1, wherein positioning an interface element via the needle includes at least one of implanting temporarily, implanting permanently, bringing in place, inserting, and affixing.
3. A method according to claim 1, wherein the interface element includes at least one of an electrode, a sensor, a catheter, a delivery device, a heat delivery device, a cold delivery device, a surgical device, a needle, a probe, a light transmission device, a tissue, a bulking material, light, heat, cold, fluid, drug, medicine, nutrient, radiation, and material.
4. A method according to claim 1, further comprising interfacing with at least one laryngeal structure using the interface element.
5. A method according to claim 4, wherein such interfacing includes at least one of stimulating a laryngeal structure, activating a laryngeal structure, blocking a laryngeal structure, inhibiting operation of a laryngeal structure, moving a laryngeal structure, removing a portion of a laryngeal structure, repairing a laryngeal structure, delivering a material to a laryngeal structure, and monitoring a laryngeal structure.
6. A method according to claim 5, wherein moving a laryngeal structure includes at least one of opening, closing, and varying tension of the laryngeal structure.
7. A method according to claim 4, wherein such interfacing includes interfacing with at least one of a single vocal cord, both vocal cords, the epiglottis, and a pharyngeal constrictor.

8. A method according to claim 1, wherein the laryngeal impairment includes at least one of unilateral vocal cord paralysis, bilateral vocal cord paralysis, dysphonia, dysphagia, and tendency of aspiration.
9. A method according to claim 1, wherein the geographical relation to the lateral wing of a vocal cord cartilage is subperichondral on an inside of cricoid cartilage lamina.
10. A method according to claim 1, wherein the geographical relation to the lateral wing of a vocal cord cartilage is on an outside of cricoid cartilage lamina.
11. A method according to claim 1, wherein the geographical relation to the lateral wing of a vocal cord cartilage is inside of a cricoid cartilage wall.
12. A method according to claim 11, wherein an insertion route of the needle is formed in a curve in the inside of the cricoid cartilage wall.
13. A method according to claim 1, wherein an insertion route of the needle is partly inside of a cricoid cartilage wall and partly subperichondral on an inside of cricoid cartilage lamina.
14. A method according to claim 1, wherein an insertion route of the needle is partly inside of a cricoid cartilage wall and partly on the outside of cricoid cartilage lamina.
15. A method according to claim 1, wherein at least one of positioning the needle and positioning the interface element is performed endoscopically.
16. A method according to claim 1, wherein positioning the needle includes performing a neck incision and starting positioning of the needle in the surgical field of the neck incision.
17. A method according to claim 1, wherein at least one of positioning the needle and positioning the interface element includes visually monitoring such positioning intraoperatively.

18. A method according to claim 1, wherein at least one of positioning the needle and positioning the interface element includes monitoring such positioning intraoperatively by neural monitoring.
19. A method according to claim 1, wherein at least one of positioning the needle and positioning the interface element includes monitoring such positioning intraoperatively by monitoring of electromyographical signals.
20. A method according to claim 1, further comprising:
 repositioning the needle; and
 repositioning the interface element via the repositioned needle.
21. A method according to claim 20, wherein repositioning the needle includes at least one of repositioning the needle with a different angle, repositioning the needle with a different direction, and repositioning the needle with a different starting point.
22. A method according to claim 20, wherein at least one of repositioning the needle and repositioning the interface element includes visually monitoring such repositioning intraoperatively.
23. A method according to claim 20, wherein at least one of repositioning the needle and repositioning the interface element includes monitoring such repositioning intraoperatively by neural monitoring.
24. A method according to claim 20, wherein at least one of repositioning the needle and repositioning the interface element includes monitoring such repositioning intraoperatively by monitoring of electromyographical signals.
25. A method according to claim 1, wherein positioning at least one interface element includes positioning a single interface element unilaterally.
26. A method according to claim 1, wherein positioning at least one interface element includes positioning a plurality of interface elements unilaterally.

27. A method according to claim 1, wherein positioning at least one interface element includes positioning a plurality of interface elements bilaterally.
28. A method according to claim 4, wherein interfacing includes delivering electrical energy to a laryngeal structure via the interface element.
29. A method according to claim 1, wherein positioning the interface element includes positioning the interface element for interfacing with a muscle.
30. A method according to claim 1, wherein positioning the interface element includes positioning the interface element for interfacing with a nerve.
31. A method according to claim 1, wherein positioning the interface element includes positioning the interface element for interfacing with a receptor.
32. A method according to claim 4, wherein interfacing includes delivering a drug to a laryngeal structure via the interface element.
33. A method according to claim 4, wherein interfacing includes at least one of receiving and recording electromyographic signals of a related muscle.
34. A method according to claim 4, wherein interfacing includes at least one of receiving and recording electroneurographic signals of a related nerve.
35. A method according to claim 1, wherein at least one of positioning the needle and positioning the interface element includes navigating using at least one of palpation, x-ray, CT, MRI, and electrical test stimulators.
36. A method according to claim 1, wherein at least one of positioning the needle and positioning the interface element includes navigating by use of a schablone manufactured according to general or the specific computer tomography data of the subject.

37. A method according to claim 1, wherein at least one of positioning the needle and positioning the interface element includes navigating by use of a mask of the throat and mandible.

38. A method according to claim 1, wherein at least one of positioning the needle and positioning the interface element includes navigating by use of a 2 or more dimensional video navigation system in relation to at least one of computer tomography, X-ray, MRI, and ultrasound data of the subject.

39. A method according to claim 1, further comprising:
 placing the interface element in communication with a controller; and
 implanting the controller in the subject.

40. A method according to claim 1, further comprising:
 placing a plurality of interface elements in communication with a controller; and
 independently controlling the interface elements by the controller.

41. A method according to claim 1, further comprising:
 placing each of a plurality of interface elements in communication with a separate controller; and
 independently controlling each interface element by its respective controller.

42. A method according to claim 4, wherein the interface element includes an electrode, and wherein the method further comprises percutaneously routing a portion of the electrode through the skin to the outside of the subject and connecting the electrode to an external stimulator for a certain duration to verify efficacy of the interfacing with laryngeal structures.

43. A method according to claim 4, wherein the interface element includes a sensor, and wherein the method further comprises percutaneously routing a portion of the sensor through the skin to the outside of the subject and connecting the sensor to an external recorder for a certain duration to verify efficacy of the interfacing with laryngeal structures.

44. A method according to claim 4, wherein the interface element includes a catheter, and wherein the method further comprises percutaneously routing a portion of the catheter

through the skin to the outside of the subject and connecting the catheter to an external pump for a certain duration to verify efficacy of the interfacing with laryngeal structures.

45. A method according to any of claims 42, 43, or 44, wherein the certain duration is from 1 to 60 minutes.

46. A method according to any of claims 42, 43, or 44, wherein the certain duration is from 1 to 24 hours.

47. A method according to any of claims 42, 43, or 44, wherein the certain duration is from 1 to 7 days.

48. A method according to any of claims 42, 43, or 44, wherein the certain duration is from 1 to 20 weeks.

49. A method according to claim 42, further comprising permanently connecting the electrode inside the subject to a surgically implanted controller in the case efficacy is proven.

50. A method according to claim 42, further comprising removing the electrode from the subject in the case efficacy has not been proven.

51. A method according to claim 43, further comprising permanently connecting the sensor inside the subject to a surgically implanted recording device in the case efficacy is proven.

52. A method according to claim 43, further comprising removing the sensor from the subject in the case efficacy has not been proven.

53. A method according to claim 44, further comprising permanently connecting the catheter inside the subject to a surgically implanted pump in the case efficacy is proven.

54. A method according to claim 44, further comprising removing the catheter from the subject in the case efficacy has not been proven.

55. A method according to claim 1, wherein a vocal cord cartilage includes at least one of the cricoid cartilage and the thyroid cartilage.

56. A method of employing an electrode in a subject with laryngeal impairments in order to facilitate movement of vocal cords, the method comprising:

 inserting a thread into a subperichondral space beneath posterior cricoarytenoid muscle;

 attaching an electrode to the thread; and

 placing the electrode near a related structure by pulling the thread.

57. A method according to claim 56, wherein movement of vocal cords includes at least one of opening, closing, and varying tension of the vocal cords.

58. A method according to claim 56, wherein laryngeal impairments include at least one of unilateral vocal cord paralysis, bilateral vocal cord paralysis, dysphonia, dysphagia, and tendency of aspiration.

59. A method according to claim 56, wherein the thread is inserted into the subperichondral space beneath the posterior cricoarytenoid muscle and cartilage from a back side of a larynx.

60. A method according to claim 56, wherein inserting the thread is done endoscopically.

61. A method according to claim 56, wherein inserting the thread is done with a needle.

62. A method according to claim 61, further comprising:

 removing the thread from the needle, wherein the needle is removed before the thread is attached to the electrode.

63. A method according to claim 56, further comprising:

 retrieving the thread after placing the electrode, wherein the thread is retrieved via a surgical neck incision.

64. A method according to claim 56, wherein placing the electrode includes optimizing a position of the electrode by moving the electrode via pulling the thread or pulling the electrode and visually monitoring the vocal cord movement intraoperatively.
65. A method according to claim 56, wherein the electrode is placed unilaterally.
66. A method according to claim 56, wherein two or more electrodes are placed bilaterally.
67. A method according to claim 56, further comprising:
activating the related structure by electrical energy delivered via the electrode.
68. A method according to claim 56, wherein the related structure is a muscle.
69. A method according to claim 56, wherein the related structure is a nerve.
70. A method according to claim 56, further comprising:
activating the related structure by a drug delivered via the electrode.
71. A method according to claim 56, further comprising sensing signals by the electrode.
72. A method according to claim 71, wherein the signals sensed by the electrode are electromyographic signals of a related muscle.
73. A method according to claim 71, wherein the signals sensed by the electrode are electroneurographic signals of a related nerve.
74. A method according to one of claims 56-73, wherein attaching the electrode to the thread is done outside a body of the subject.
75. A method according to one of claims 56-73, wherein attaching the electrode to the thread is done in an area where surgery is performed on the subject, or in a vicinity of the area.
76. A method of introducing interface elements for interfacing with laryngeal structures of a subject such as for diagnosis or treatment of a laryngeal impairment, the method comprising:

generating a tunnel in geographical relation to the lateral wing of the cricoid cartilage of the subject; and

introducing at least one interface element via the tunnel for interfacing with at least one laryngeal structure of the subject.

77. A method according to claim 76, wherein introducing includes at least one of positioning, implanting temporarily, implanting permanently, bringing in place, inserting, and affixing.

78. A method according to claim 76, wherein the at least one interface element includes at least one of an electrode, a sensor, a catheter, a delivery device, a heat delivery device, a cold delivery device, a surgical device, a needle, a probe, a light transmission device, a tissue, a bulking material, light, heat, cold, fluid, drug, medicine, nutrient, radiation, and material.

79. A method according to claim 76, further comprising interfacing with at least one laryngeal structure using the at least one interface element.

80. A method according to claim 76, wherein such interfacing includes at least one of stimulating a laryngeal structure, activating a laryngeal structure, blocking a laryngeal structure, inhibiting operation of a laryngeal structure, moving a laryngeal structure, removing a portion of a laryngeal structure, repairing a laryngeal structure, delivering a material to a laryngeal structure, and monitoring a laryngeal structure.

81. A method according to claim 80, wherein moving a laryngeal structure includes at least one of opening, closing, and varying tension of the laryngeal structure.

82. A method according to claim 79, wherein such interfacing includes interfacing with at least one of a single vocal cord, both vocal cords, the epiglottis, and a pharyngeal constrictor.

83. A method according to claim 76, wherein the laryngeal impairment includes at least one of unilateral vocal chord paralysis, bilateral vocal chord paralysis, dysphonia, dysphagia, and tendency of aspiration.

84. A method according to claim 76, wherein at least a portion of the tunnel is subperichondral on an inside of cricoid cartilage lamina.

85. A method according to claim 76, wherein at least a portion of the tunnel is on an outside of cricoid cartilage lamina.

86. A method according to claim 76, wherein at least a portion of the tunnel is inside of a cricoid cartilage wall.

87. A method according to claim 76, wherein at least a portion of the tunnel is formed in a curve in the inside of the cricoid cartilage wall.

88. A method according to claim 76, wherein at least a portion of the tunnel is partly inside of a cricoid cartilage wall and partly subperichondral on an inside of cricoid cartilage lamina.

89. A method according to claim 76, wherein at least a portion of the tunnel is partly inside of a cricoid cartilage wall and partly on the outside of cricoid cartilage lamina.

90. A method according to claim 76, wherein at least one of the generating and the introducing is performed endoscopically.

91. A method according to claim 76, wherein generating the tunnel includes performing a neck incision and starting the tunnel in the surgical field of the neck incision.

92. A method according to claim 76, wherein introducing the at least one interface element includes visually monitoring such introduction intraoperatively.

93. A method according to claim 76, wherein introducing the at least one interface element includes monitoring such introduction intraoperatively by neural monitoring.

94. A method according to claim 76, wherein introducing the at least one interface element includes monitoring such introduction intraoperatively by monitoring of electromyographical signals.

95. A method according to claim 76, further comprising:
re-generating the tunnel; and

introducing at least one interface element via the re-generated tunnel.

96. A method according to claim 95, wherein re-generating the tunnel includes at least one of re-generating the tunnel with a different angle, re-generating the tunnel with a different direction, and re-generating the tunnel with a different starting point.

97. A method according to claim 95, wherein introducing via the re-generated tunnel includes visually monitoring such introduction intraoperatively.

98. A method according to claim 95, wherein introducing via the re-generated tunnel includes monitoring such introduction intraoperatively by neural monitoring.

99. A method according to claim 95, wherein introducing via the re-generated tunnel includes monitoring such introduction intraoperatively by monitoring of electromyographical signals.

100. A method according to claim 76, wherein introducing the at least one interface element includes positioning a single interface element unilaterally.

101. A method according to claim 76, wherein introducing the at least one interface element includes positioning a plurality of interface elements unilaterally.

102. A method according to claim 76, wherein introducing the at least one interface element includes positioning a plurality of interface elements bilaterally.

103. A method according to claim 79, wherein interfacing includes delivering electrical energy to a laryngeal structure via at least one interface element.

104. A method according to claim 76, wherein introducing at least one interface element via the tunnel for interfacing with at least one laryngeal structure of the subject includes introducing the at least one interface element for interfacing with a muscle.

105. A method according to claim 76, wherein introducing at least one interface element via the tunnel for interfacing with at least one laryngeal structure of the subject includes introducing the at least one interface element for interfacing with a nerve.

106. A method according to claim 76, wherein introducing at least one interface element via the tunnel for interfacing with at least one laryngeal structure of the subject includes introducing the at least one interface element for interfacing with a receptor.
107. A method according to claim 79, wherein interfacing includes delivering a drug to a laryngeal structure via at least one interface element.
108. A method according to claim 79, wherein interfacing includes at least one of receiving and recording electromyographic signals of a related muscle.
109. A method according to claim 79, wherein interfacing includes at least one of receiving and recording electroneurographic signals of a related nerve.
110. A method according to claim 76, wherein at least one of generating the tunnel and introducing the at least one interface element includes navigating using at least one of palpation, x-ray, CT, MRI, and electrical test stimulators.
111. A method according to claim 76, wherein at least one of generating the tunnel and introducing the at least one interface element includes navigating by use of a schablone manufactured according to general or the specific computer tomography data of the subject.
112. A method according to claim 76, wherein at least one of generating the tunnel and introducing the at least one interface element includes navigating by use of a mask of the throat and mandible.
113. A method according to claim 76, wherein at least one of generating the tunnel and introducing the at least one interface element includes navigating by use of a 2 or more dimensional video navigation system in relation to at least one of computer tomography, X-ray, MRI, and ultrasound data of the subject.
114. A method according to claim 76, further comprising:
placing at least one interface element in communication with a controller; and
implanting the controller in the subject.

115. A method according to claim 76, wherein generating the tunnel is performed using at least one of a drill, a laser, a water beam, a heating tool, and a high frequency tool.

116. A method according to claim 76, further comprising:
placing a plurality of interface elements in communication with a controller; and
independently controlling the interface elements by the controller.

117. A method according to claim 76, further comprising:
placing each of a plurality of interface elements in communication with a separate controller; and
independently controlling each interface element by its respective controller.

118. A method according to claim 79, wherein the interface element includes an electrode, and wherein the method further comprises percutaneously routing a portion of the electrode through the skin to the outside of the subject and connecting the electrode to an external stimulator for a certain duration to verify efficacy of the interfacing with laryngeal structures.

119. A method according to claim 79, wherein the interface element includes a sensor, and wherein the method further comprises percutaneously routing a portion of the sensor through the skin to the outside of the subject and connecting the sensor to an external recorder for a certain duration to verify efficacy of the interfacing with laryngeal structures.

120. A method according to claim 79, wherein the interface element includes a catheter, and wherein the method further comprises percutaneously routing a portion of the catheter through the skin to the outside of the subject and connecting the catheter to an external pump for a certain duration to verify efficacy of the interfacing with laryngeal structures.

121. A method according to any of claims 118, 119, or 120, wherein the certain duration is from 1 to 60 minutes.

122. A method according to any of claims 118, 119, or 120, wherein the certain duration is from 1 to 24 hours.

123. A method according to any of claims 118, 119, or 120, wherein the certain duration is from 1 to 7 days.

124. A method according to any of claims 118, 119, or 120, wherein the certain duration is from 1 to 20 weeks.

125. A method according to claim 118, further comprising permanently connecting the electrode inside the subject to a surgically implanted controller in the case efficacy is proven.

126. A method according to claim 118, further comprising removing the electrode from the subject in the case efficacy has not been proven.

127. A method according to claim 119, further comprising permanently connecting the sensor inside the subject to a surgically implanted recording device in the case efficacy is proven.

128. A method according to claim 119, further comprising removing the sensor from the subject in the case efficacy has not been proven.

129. A method according to claim 120, further comprising permanently connecting the catheter inside the subject to a surgically implanted pump in the case efficacy is proven.

130. A method according to claim 120, further comprising removing the catheter from the subject in the case efficacy has not been proven.

131. A method of introducing interface elements for interfacing with laryngeal structures of a subject such as for diagnosis or treatment of a laryngeal impairment, the method comprising:

generating a tunnel in geographical relation to the lateral wing of the thyroid cartilage of the subject; and

introducing at least one interface element via the tunnel for interfacing with at least one laryngeal structure of the subject.

132. A method according to claim 131, wherein introducing includes at least one of positioning, implanting temporarily, implanting permanently, bringing in place, inserting, and affixing.

133. A method according to claim 131, wherein the at least one interface element includes at least one of an electrode, a sensor, a catheter, a delivery device, a heat delivery device, a cold delivery device, a surgical device, a needle, a probe, a light transmission device, a tissue, a bulking material, light, heat, cold, fluid, drug, medicine, nutrient, radiation, and material.

134. A method according to claim 131, further comprising interfacing with at least one laryngeal structure using the at least one interface element.

135. A method according to claim 134, wherein such interfacing includes at least one of stimulating a laryngeal structure, activating a laryngeal structure, blocking a laryngeal structure, inhibiting operation of a laryngeal structure, moving a laryngeal structure, removing a portion of a laryngeal structure, repairing a laryngeal structure, delivering a material to a laryngeal structure, and monitoring a laryngeal structure.

136. A method according to claim 135, wherein moving a laryngeal structure includes at least one of opening, closing, and varying tension of the laryngeal structure.

137. A method according to claim 134, wherein such interfacing includes interfacing with at least one of a single vocal cord, both vocal cords, the epiglottis, and a pharyngeal constrictor.

138. A method according to claim 131, wherein the laryngeal impairment includes at least one of unilateral vocal chord paralysis, bilateral vocal chord paralysis, dysphonia, dysphagia, and tendency of aspiration.

139. A method according to claim 131, wherein at least a portion of the tunnel is medial of the thyroid cartilage.

140. A method according to claim 131, wherein the tunnel is generated at least in part by introduction of an interface element.

141. A method according to claim 131, wherein the tunnel includes a part of a subperichondral tunnel on an inside of thyroid cartilage lamina.
142. A method according to claim 131, wherein the tunnel includes a part of a subperichondral tunnel on an outside of thyroid cartilage lamina.
143. A method according to claim 131, wherein the tunnel includes a part of a tunnel drilled inside of a thyroid cartilage wall.
144. A method according to claim 131, wherein the drilled tunnel is formed in a curve in the inside of the thyroid cartilage wall.
145. A method according to claim 131, wherein the tunnel is drilled partly inside of a cricoid cartilage wall and includes a subperichondral tunnel on an inside of cricoid cartilage lamina.
146. A method according to claim 131, wherein the tunnel is drilled partly inside of a cricoid cartilage wall and partly on the outside of cricoid cartilage lamina.
147. A method according to claim 131, wherein at least one of the generating and the introducing is performed endoscopically.
148. A method according to claim 131, wherein generating the tunnel includes performing a neck incision and starting the tunnel in the surgical field of the neck incision.
149. A method according to claim 131, wherein introducing the at least one interface element includes visually monitoring such introduction intraoperatively.
150. A method according to claim 131, wherein introducing the at least one interface element includes monitoring such introduction intraoperatively by neural monitoring.

151. A method according to claim 131, wherein introducing the at least one interface element includes monitoring such introduction intraoperatively by monitoring of electromyographical signals.
152. A method according to claim 131, further comprising:
re-generating the tunnel; and
introducing at least one interface element via the re-generated tunnel.
153. A method according to claim 152, wherein re-generating the tunnel includes at least one of re-generating the tunnel with a different angle, re-generating the tunnel with a different direction, and re-generating the tunnel with a different starting point.
154. A method according to claim 152, wherein introducing via the re-generated tunnel includes visually monitoring such introduction intraoperatively.
155. A method according to claim 152, wherein introducing via the re-generated tunnel includes monitoring such introduction intraoperatively by neural monitoring.
156. A method according to claim 152, wherein introducing via the re-generated tunnel includes monitoring such introduction intraoperatively by monitoring of electromyographical signals.
157. A method according to claim 131, wherein introducing the at least one interface element includes positioning a single interface element unilaterally.
158. A method according to claim 131, wherein introducing the at least one interface element includes positioning a plurality of interface elements unilaterally.
159. A method according to claim 131, wherein introducing the at least one interface element includes positioning a plurality of interface elements bilaterally.
160. A method according to claim 134, wherein interfacing includes delivering electrical energy to a laryngeal structure via at least one interface element.

161. A method according to claim 131 wherein introducing at least one interface element via the tunnel for interfacing with at least one laryngeal structure of the subject includes introducing the at least one interface element for interfacing with a muscle.

162. A method according to claim 131, wherein introducing at least one interface element via the tunnel for interfacing with at least one laryngeal structure of the subject includes introducing the at least one interface element for interfacing with a nerve.

163. A method according to claim 131, wherein introducing at least one interface element via the tunnel for interfacing with at least one laryngeal structure of the subject includes introducing the at least one interface element for interfacing with a receptor.

164. A method according to claim 134, wherein interfacing includes delivering a drug to a laryngeal structure via at least one interface element.

165. A method according to claim 134, wherein interfacing includes at least one of receiving and recording electromyographic signals of a related muscle.

166. A method according to claim 134, wherein interfacing includes at least one of receiving and recording electroneurographic signals of a related nerve.

167. A method according to claim 131, wherein at least one of generating the tunnel and introducing the at least one interface element includes navigating using at least one of palpation, x-ray, CT, MRI, and electrical test stimulators.

168. A method according to claim 131, wherein at least one of generating the tunnel and introducing the at least one interface element includes navigating by use of a schablone manufactured according to general or the specific computer tomography data of the subject.

169. A method according to claim 131, wherein at least one of generating the tunnel and introducing the at least one interface element includes navigating by use of a mask of the throat and mandible.

170. A method according to claim 131, wherein at least one of generating the tunnel and introducing the at least one interface element includes navigating by use of a 2 or more dimensional video navigation system in relation to at least one of computer tomography, X-ray, MRI, and ultrasound data of the subject.
171. A method according to claim 131, further comprising:
placing at least one interface element in communication with a controller; and
implanting the controller in the subject.
172. A method according to claim 131, wherein generating the tunnel is performed using at least one of a drill, a laser, a water beam, a heating tool, and a high frequency tool.
173. A method according to claim 131, further comprising:
placing a plurality of interface elements in communication with a controller; and
independently controlling the interface elements by the controller.
174. A method according to claim 131, further comprising:
placing each of a plurality of interface elements in communication with a separate controller; and
independently controlling each interface element by its respective controller.
175. A method according to claim 135, wherein the interface element includes an electrode, and wherein the method further comprises percutaneously routing a portion of the electrode through the skin to the outside of the subject and connecting the electrode to an external stimulator for a certain duration to verify efficacy of the interfacing with laryngeal structures.
176. A method according to claim 135, wherein the interface element includes a sensor, and wherein the method further comprises percutaneously routing a portion of the sensor through the skin to the outside of the subject and connecting the sensor to an external recorder for a certain duration to verify efficacy of the interfacing with laryngeal structures.
177. A method according to claim 135, wherein the interface element includes a catheter, and wherein the method further comprises percutaneously routing a portion of the catheter

through the skin to the outside of the subject and connecting the catheter to an external pump for a certain duration to verify efficacy of the interfacing with laryngeal structures.

178. A method according to any of claims 175, 176, or 177, wherein the certain duration is from 1 to 60 minutes.

179. A method according to any of claims 175, 176, or 177, wherein the certain duration is from 1 to 24 hours.

180. A method according to any of claims 175, 176, or 177, wherein the certain duration is from 1 to 7 days.

181. A method according to any of claims 175, 176, or 177, wherein the certain duration is from 1 to 20 weeks.

182. A method according to claim 175, further comprising permanently connecting the electrode inside the subject to a surgically implanted controller in the case efficacy is proven.

183. A method according to claim 175, further comprising removing the electrode from the subject in the case efficacy has not been proven.

184. A method according to claim 176, further comprising permanently connecting the sensor inside the subject to a surgically implanted recording device in the case efficacy is proven.

185. A method according to claim 176, further comprising removing the sensor from the subject in the case efficacy has not been proven.

186. A method according to claim 177, further comprising permanently connecting the catheter inside the subject to a surgically implanted pump in the case efficacy is proven.

187. A method according to claim 177, further comprising removing the catheter from the subject in the case efficacy has not been proven.

188. A system for positioning an interface element, the system comprising:
one or more hollow members adapted to telescope into an outermost hollow member, the outermost hollow member having a structure at a first end,
wherein a hollow member is at an angle relative to the outermost hollow member due to the structure at the first end of the outermost hollow member when a portion of the hollow member is extending from the outermost hollow member, and wherein the interface element is capable of being moved through at least one of the hollow members from a first position to a second position.
189. The system according to claim 188, wherein at least one of the first position and second position is at least one of a position on skin of a subject, a position on a border of a cavity inside a body of a subject, a position inside a body of a subject, and a position on a surface or inside an organ in a body of a subject.
190. The system according to claim 188, further comprising the interface element.
191. The system according to claim 190, wherein the interface element is at least one of an electrode, a sensor, a catheter, a delivery device, a heat delivery device, a cold delivery device, a surgical device, a probe, a light transmission device, a tissue, a material, a bulking material, a needle, heat, cold, fluid, drug, medicine, nutrient, and radiation.
192. The system according to claim 190, wherein the interface element is adapted to interface with at least one laryngeal structure.
193. The system according to claim 192, wherein the interface element is adapted to one of stimulate at least one of the laryngeal structures, activate the laryngeal structures, block the laryngeal structures, inhibit operation of the laryngeal structures, move the laryngeal structures, remove a portion of the laryngeal structures, repair the laryngeal structures, and deliver a material to the laryngeal structures.
194. The system according to claim 188, wherein the hollow members are capable of retracting after the interface element is transported between the first position and the second position.

195. The system according to claim 188, wherein the structure at the tip includes one of a curved member or an angled member.

196. The system according to claim 188, wherein the structure includes means for bending a hollow member upon extending from the tip of the outermost hollow member, and for straightening a hollow member upon retracting into the tip of the outermost hollow member.

197. The system according to claim 188, where at least one of the hollow members is a hollow needle.

198. A method of positioning an interface element, the method comprising:
inserting a telescoping unit, the telescoping unit including one or more hollow members adapted to telescope into an outermost hollow member, the outermost hollow member having a structure at a first end; and
extending a portion of at least one hollow member beyond the tip of the outermost hollow member such that that at least one hollow member is at an angle relative to the outermost hollow member due to the structure at the tip of the outermost hollow member.

199. The method according to claim 198, further comprising extending at least one of the hollow members.

200. The method according to claim 199, further comprising moving the interface element through at least one of the hollow members from a first position to a second position.

201. The method according to claim 200, further comprising retracting at least one of the hollow members.

202. The method according to claim 200, wherein at least one of the first position and second position is at least one of a position on skin of the subject, a position on a border of a cavity inside a body of the subject, a position inside a body of a subject, and a position on a surface or inside an organ in a body of the subject.

203. The method according to claim 200, wherein the interface element is at least one of an electrode, a sensor, a catheter, a delivery device, a heat delivery device, a cold delivery

device, a surgical device, a probe, a light transmission device, a tissue, a material, a bulking material, a needle, heat, cold, fluid, drug, medicine, nutrient, and radiation.

204. The method according to claim 198, wherein the telescoping unit is inserted endoscopically.

205. The method according to claim 198, wherein the structure at the tip includes one of a curved member and an angled member.

206. A system for transporting at least one interface element from a first location related to a subject to a second location related to the subject, the system comprising:

an outer hollow member, the outer hollow member having an inner surface with a first diameter and a structure at a tip of the outer hollow member; and

an inner hollow member having an outer surface with a second diameter, wherein the second diameter is smaller than the first diameter so that the inner hollow member fits within the inner surface of the outer hollow member,

wherein the inner hollow member is at an angle relative to the outer hollow member due to the structure at the tip of the outer hollow member when a portion of the inner hollow member extends beyond the tip of the outer hollow member.

207. The system according to claim 206, wherein the inner hollow member further includes an inner surface having a third diameter and a structure at a tip of the inner hollow member, the system further comprising:

a second inner hollow member having an outer surface with a fourth diameter, wherein the fourth diameter is smaller than the third diameter so that the second inner hollow member fits within the inner surface of the inner hollow member,

wherein the second inner hollow member is at an angle relative to the inner hollow member due to the structure at the tip of the inner hollow member when a portion of the second inner hollow member extends beyond the tip of the inner hollow member.

208. The system according to claim 206, wherein at least one of the first location and the second location is at least one of a position on skin of the subject, a position on a border of a cavity inside a body of the subject, a position inside a body of a subject, and a position on a

surface or inside an organ in a body of the subject.

209. The system according to claim 206, wherein the at least one interface element includes an electrode, a sensor, a catheter, a delivery device, a heat delivery device, a cold delivery device, a surgical device, a probe, a light transmission device, a tissue, a material, a bulking material, a needle, heat, cold, fluid, drug, medicine, nutrient, and radiation.

210. The system according to claim 206, wherein the system is capable of retracting after the interface element is transported between the first and second locations.

211. The system according to claim 206, wherein the structure at the tip includes a curved member or an angled member.

212. A method for transporting at least one interface element from a first location related to a subject to a second location related to the subject, the method comprising:

inserting a curved hollow arrangement, the curved hollow arrangement including an outer hollow member and an inner hollow member, the outer hollow member having an inner surface with a first diameter and a structure at a tip of the outer hollow member and the inner hollow member having an outer surface with a second diameter, wherein the second diameter is smaller than the first diameter so that the inner hollow member fits within the inner surface of the outer hollow member; and

extending a portion of the inner hollow member beyond the tip of the outer hollow member such that the inner hollow member is at an angle relative to the outer hollow member due to the structure at the tip of the outer hollow member.

213. The method according to claim 212, wherein the inner hollow member further includes an inner surface with a third diameter and a structure at a tip of the inner hollow member and the curved hollow arrangement further includes a second inner hollow member having an outer surface with a fourth diameter, wherein the fourth diameter is smaller than the third diameter so that the second inner hollow member fits within the inner surface of inner hollow member, the method further comprising:

extending a portion of the second inner hollow member beyond the tip of the inner hollow member such that the second inner hollow member is at an angle relative to the inner hollow member due to the structure at the tip of the inner hollow member.

214. The method according to claim 212, wherein the first or second location is at least one of a position on skin of the subject, a position on a border of a cavity inside a body of the subject, a position inside a body of a subject, and a position on a surface or inside an organ in a body of the subject.

215. The method according to claim 212, wherein the at least one interface element includes at least one of an electrode, a sensor, a catheter, a delivery device, a heat delivery device, a cold delivery device, a surgical device, a probe, a light transmission device, a tissue, a material, a bulking material, a needle, heat, cold, fluid, drug, medicine, nutrient, and radiation.

216. The method according to claim 212, wherein the curved hollow arrangement is inserted endoscopically.

217. The method according to claim 212, wherein the curved hollow arrangement is retracted after the at least one interface element is transported between the first and second locations.

218. The method according to claim 212, wherein the structure at the tip includes a curved member or an angled member.

219. A system for transporting at least one interface element from a first location related to a subject to a second location related to the subject, the system comprising:

- an outer hollow member having a tip and an inner surface with a first diameter; and
- a curved inner hollow member having an outer surface with a second diameter,

wherein the second diameter is smaller than the first diameter so that the curved inner hollow member fits within the inner surface of the outer hollow member,

- wherein the curved inner hollow member is at an angle relative to the outer hollow member when a portion of the curved inner hollow member extends beyond the tip of the outer hollow member

220. The system according to claim 219, wherein the curved inner hollow member further includes a tip and an inner surface having a third diameter, the system further comprising:

a second curved inner hollow member having an outer surface with a fourth diameter, wherein the fourth diameter is smaller than the third diameter so that the second curved inner hollow member fits within the inner surface of the curved inner hollow member,

wherein the second curved inner hollow member is at an angle relative to the curved inner hollow member when a portion of the second curved inner hollow member extends beyond the tip of the curved inner hollow member.

221. The system according to claim 219, wherein at least one of the first location and the second location is at least one of a position on skin of the subject, a position on a border of a cavity inside a body of the subject, a position inside a body of a subject, and a position on a surface or inside an organ in a body of the subject.

222. The system according to claim 219, wherein the at least one interface element includes an electrode, a sensor, a catheter, a delivery device, a heat delivery device, a cold delivery device, a surgical device, a probe, a light transmission device, a tissue, a material, a bulking material, a needle, heat, cold, fluid, drug, medicine, nutrient, and radiation.

223. The system according to claim 219, wherein the system is capable of retracting after the at least one interface element is transported between the first and second locations.

224. The system according to claim 219, wherein the structure at the tip of the outer hollow member includes a curved part or an angled part.

225. A method for transporting at least one interface element from a first location related to a subject to a second location related to the subject, the method comprising:

inserting a curved hollow arrangement, the curved hollow arrangement including an outer hollow member and a curved inner hollow member, the outer hollow member having a tip and an inner surface with a first diameter and the curved inner hollow member having an outer surface with a second diameter, wherein the second diameter is smaller than the first diameter so that the curved inner hollow member fits within the inner surface of the outer hollow member; and

extending a portion of the curved inner hollow member beyond the tip of the outer hollow member such that the inner hollow member is at an angle relative to the outer hollow member.

226. The method according to claim 225, wherein the curved inner hollow member further includes a tip and an inner surface having a third diameter and the curved hollow arrangement further includes a second curved inner hollow member having an outer surface with a fourth diameter, wherein the fourth diameter is smaller than the third diameter so that the second curved inner hollow member fits within the inner surface of curved inner hollow member, the method further comprising:

extending a portion of the second curved inner hollow member beyond the tip of the curved inner hollow member such that the second curved inner hollow member is at an angle relative to the curved inner hollow member.

227. The method according to claim 225, wherein at least one of the first location and the second location is at least one of a position on skin of the subject, a position on a border of a cavity inside a body of the subject, a position inside a body of a subject, and a position on a surface or inside an organ in a body of the subject.

228. The method according to claim 225, wherein the interface element includes an electrode, a sensor, a catheter, a delivery device, a heat delivery device, a cold delivery device, a surgical device, a probe, a light transmission device, a tissue, a material, a bulking material, a needle, heat, cold, fluid, drug, medicine, nutrient, and radiation.

229. The method according to claim 225, wherein the curved hollow arrangement is inserted endoscopically.

230. The method according to claim 225, wherein the curved hollow arrangement is retracted after the at least one interface element is transported between the first and second locations.

231. A system for providing a path between two targets of a subject so as to transport at least one interface element from one target to the other target, the system comprising:

a first outer hollow member;
a structure at the tip of the first outer member; and
a second inner hollow member with a smaller diameter than the first outer hollow member so that the second inner hollow member fits into the first outer hollow member,

wherein the second inner hollow member leaves the first outer member in a relative angle when moving the second inner hollow member outside the first outer hollow member because of the structure at the tip of the first outer member.

232. The system according to claim 231, further comprising:

a structure at the tip of the second inner member; and

a third inner hollow member with a smaller diameter than the second inner hollow member so that the third inner hollow member fits into the second inner hollow member, wherein the third inner hollow member leaves the second inner member in a relative angle when moving the third inner hollow member outside the second inner hollow member because of the structure at the tip of the second inner member.

233. A method for providing a path between two targets of a subject so as to transport at least one interface element from one target to the other by a curved hollow member, the method comprising:

inserting a first outer hollow member, the first outer hollow member having a structure at a tip of the first outer member; and

extending a second inner hollow member with a smaller diameter than the first outer hollow member so that the second inner hollow member fits into the first outer hollow member,

wherein the second inner hollow member leaves the first outer member in a relative angle when extending the second inner hollow member beyond the first outer hollow member because of the structure at the tip of the first outer member.

234. The method according to claim 233, wherein the second inner member has a structure at a tip of the second inner member, the method further comprising:

extending a third inner hollow member with a smaller diameter than the second inner hollow member so that the third inner hollow member fits into the second inner hollow member,

wherein the third inner hollow member leaves the second inner member in a relative angle when extending the third inner hollow member beyond the second inner hollow member because of the structure at the tip of the second inner member.

235. A system for providing a path between two targets of a subject so as to transport at least one interface element from one target to the other, the system comprising:

a first outer hollow member; and

a second inner hollow member with a smaller diameter than the first outer hollow member so that the second inner hollow member fits into the first outer hollow member, wherein the second inner hollow member curves relative to the first outer hollow member when moving the second inner hollow member outside the first outer hollow member because of a pre-manufactured curve of the second inner hollow member, wherein the second inner hollow member is not curved relative to the first outer hollow member while the second inner hollow member is tight against the first outer member.

236. The system according to claim 235, further comprising:

a third inner hollow member with a smaller diameter than the second inner hollow member so that the third inner hollow member fits into the second inner hollow member,

wherein the third inner hollow member curves relative to the second inner hollow member when moving the third inner hollow member outside the second inner hollow member because of pre-manufactured different curve of the third inner hollow member, wherein the third inner hollow member is not curved relative to the second outer hollow member while the third inner hollow member is tight against the second inner member.

237. A method of positioning an interface element for interfacing with laryngeal structures in a subject such as for diagnosis or treatment of a laryngeal impairment, the method comprising:

inserting a curved hollow needle system into a subperichondral space beneath posterior cricoarytenoid muscle from the larynx;

pushing the curved hollow needle system in a curve around cartilage at least until the curved hollow needle is seen from outside of a body of the subject;

retracting the curved hollow needle system back into the larynx along a retraction route; and

positioning at least one interface element at a desired position along the retraction route.

238. A method according to claim 237, wherein positioning an interface element includes at least one of implanting temporarily, implanting permanently, bringing in place, inserting, and affixing.

239. A method according to claim 237, wherein the interface element includes at least one of an electrode, a sensor, a catheter, a delivery device, a heat delivery device, a cold delivery device, a surgical device, a needle, a probe, a light transmission device, a tissue, a bulking material, light, heat, cold, fluid, drug, medicine, nutrient, radiation, and material.

240. A method according to claim 237, further comprising interfacing with at least one laryngeal structure using the interface element.

241. A method according to claim 240, wherein such interfacing includes at least one of stimulating a laryngeal structure, activating a laryngeal structure, blocking a laryngeal structure, inhibiting operation of a laryngeal structure, moving a laryngeal structure, removing a portion of a laryngeal structure, repairing a laryngeal structure, delivering a material to a laryngeal structure, and monitoring a laryngeal structure.

242. A method according to claim 241, wherein moving a laryngeal structure includes at least one of opening, closing, and varying tension of the laryngeal structure.

243. A method according to claim 240, wherein such interfacing includes interfacing with at least one of a single vocal cord, both vocal cords, the epiglottis, and a pharyngeal constrictor.

244. A method according to claim 237, wherein the laryngeal impairment includes at least one of unilateral vocal cord paralysis, bilateral vocal cord paralysis, dysphonia, dysphagia, and tendency of aspiration.

245. A method according to claim 237, wherein positioning the needle system includes performing a neck incision and starting positioning of the needle system in the surgical field of the neck incision.

246. A method according to claim 237, wherein positioning the interface element includes visually monitoring such positioning intraoperatively.
247. A method according to claim 237, wherein positioning the interface element includes monitoring such positioning intraoperatively by neural monitoring.
248. A method according to claim 237, wherein positioning the interface element includes monitoring such positioning intraoperatively by monitoring of electromyographical signals.
249. A method according to claim 237, further comprising:
repositioning the needle system; and
repositioning the interface element via the repositioned needle system.
250. A method according to claim 249, wherein repositioning the needle system includes at least one of repositioning the needle system with a different angle, repositioning the needle system with a different direction, and repositioning the needle system with a different starting point.
251. A method according to claim 249, wherein at least one of repositioning the needle system and repositioning the interface element includes visually monitoring such repositioning intraoperatively.
252. A method according to claim 249, wherein at least one of repositioning the needle system and repositioning the interface element includes monitoring such repositioning intraoperatively by neural monitoring.
253. A method according to claim 249, wherein at least one of repositioning the needle system and repositioning the interface element includes monitoring such repositioning intraoperatively by monitoring of electromyographical signals.
254. A method according to claim 237, wherein positioning at least one interface element includes positioning a single interface element unilaterally.

255. A method according to claim 237, wherein positioning at least one interface element includes positioning a plurality of interface elements unilaterally.
256. A method according to claim 237, wherein positioning at least one interface element includes positioning a plurality of interface elements bilaterally.
257. A method according to claim 240, wherein interfacing includes delivering electrical energy to a laryngeal structure via the interface element.
258. A method according to claim 237, wherein positioning the interface element includes positioning the interface element for interfacing with a muscle.
259. A method according to claim 237, wherein positioning the interface element includes positioning the interface element for interfacing with a nerve.
260. A method according to claim 237, wherein positioning the interface element includes positioning the interface element for interfacing with a receptor.
261. A method according to claim 240, wherein interfacing includes delivering a drug to a laryngeal structure via the interface element.
262. A method according to claim 240, wherein interfacing includes at least one of receiving and recording electromyographic signals of a related muscle.
263. A method according to claim 240, wherein interfacing includes at least one of receiving and recording electroneurographic signals of a related nerve.
264. A method according to claim 237, wherein at least one of positioning the needle system and positioning the interface element includes navigating using at least one of palpation, x-ray, CT, MRI, and electrical test stimulators.
265. A method according to claim 237, wherein at least one of positioning the needle system and positioning the interface element includes navigating by use of a schablone manufactured according to general or the specific computer tomography data of the subject.

266. A method according to claim 237, wherein at least one of positioning the needle system and positioning the interface element includes navigating by use of a mask of the throat and mandible.
267. A method according to claim 237, wherein at least one of positioning the needle system and positioning the interface element includes navigating by use of a 2 or more dimensional video navigation system in relation to at least one of computer tomography, X-ray, MRI, and ultrasound data of the subject.
268. A method according to claim 237, further comprising:
placing the interface element in communication with a controller; and
implanting the controller in the subject.
269. A method according to claim 237, further comprising:
placing a plurality of interface elements in communication with a controller; and
independently controlling the interface elements by the controller.
270. A method according to claim 237, further comprising:
placing each of a plurality of interface elements in communication with a separate controller; and
independently controlling each interface element by its respective controller.
271. A method according to claim 240, wherein the interface element includes an electrode, and wherein the method further comprises percutaneously routing a portion of the electrode through the skin to the outside of the subject and connecting the electrode to an external stimulator for a certain duration to verify efficacy of the interfacing with laryngeal structures.
272. A method according to claim 240, wherein the interface element includes a sensor, and wherein the method further comprises percutaneously routing a portion of the sensor through the skin to the outside of the subject and connecting the sensor to an external recorder for a certain duration to verify efficacy of the interfacing with laryngeal structures.

273. A method according to claim 240, wherein the interface element includes a catheter, and wherein the method further comprises percutaneously routing a portion of the catheter through the skin to the outside of the subject and connecting the catheter to an external pump for a certain duration to verify efficacy of the interfacing with laryngeal structures.

274. A method according to any of claims 271, 272, or 273, wherein the certain duration is from 1 to 60 minutes.

275. A method according to any of claims 271, 272, or 273, wherein the certain duration is from 1 to 24 hours.

276. A method according to any of claims 271, 272, or 273, wherein the certain duration is from 1 to 7 days.

277. A method according to any of claims 271, 272, or 273, wherein the certain duration is from 1 to 20 weeks.

278. A method according to claim 271, further comprising permanently connecting the electrode inside the subject to a surgically implanted controller in the case efficacy is proven.

279. A method according to claim 271, further comprising removing the electrode from the subject in the case efficacy has not been proven.

280. A method according to claim 272, further comprising permanently connecting the sensor inside the subject to a surgically implanted recording device in the case efficacy is proven.

281. A method according to claim 272, further comprising removing the sensor from the subject in the case efficacy has not been proven.

282. A method according to claim 273, further comprising permanently connecting the catheter inside the subject to a surgically implanted pump in the case efficacy is proven.

283. A method according to claim 273, further comprising removing the catheter from the subject in the case efficacy has not been proven.

284. A method according to claim 237, wherein positioning the at least one interface element includes inserting an interface element into the curved hollow needle system after the needle system has left the skin.

285. A method according to claim 284, wherein the at least one interface element is pre-disposed within the hollow curved needle system, and wherein positioning of the at least one interface element occurs at least in part upon such retraction of the needle system.

286. A method according to claim 237, wherein the curved hollow needle system includes a thread connected to the at least one interface element.

287. A method according to claim 287, wherein positioning of the at least one interface element occurs at least in part upon such retraction of the needle system and consequent pulling on the thread.

288. A method according to claim 237, wherein the curved needle system is inserted into the subperichondral space beneath the posterior cricoarytenoid muscle and cartilage from a back side of the larynx.

289. A system for positioning at least one interface element for interfacing with laryngeal structures in a subject, the system comprising:

a hollow needle having an inner area for the at least one interface element to be inserted through the hollow needle, the hollow needle having a curve that allows the hollow needle to curve around cartilage.

290. A system for positioning at least one interface element for interfacing with laryngeal structures in a subject, the system comprising:

a needle having connected thereto a thread for connection with the at least one interface element to allow for retraction of the needle and the at least one interface element together, the needle having a curve that allows the needle to curve around cartilage.

291. A method of employing an interface element in a subject in order to facilitate interfacing with vocal cords such as for diagnosis or treatment of a laryngeal impairment, the method comprising:

inserting a needle into a subperichondral space beneath posterior cricoarytenoid muscle, the needle being curved and hollow;

pushing the needle around cartilage so that the needle is accessible externally from the subject;

inserting an interface element through the curved hollow needle; and

retracting the curved hollow needle into a larynx while placing the interface element in a desired position.

292. The method according to claim 291, wherein the curved hollow needle includes a thread, the method further comprising inserting the thread into the subperichondral space beneath the posterior cricoarytenoid muscle and cartilage from a back side of the larynx.

293. The method according to claim 291, wherein pushing the needle includes pushing the needle until the needle is seen from outside of the subject.

294. The method according to claim 293, wherein pushing the needle includes making the needle leave the subject through skin.

295. The method according to claim 291, wherein pushing the needle includes forcing the needle to appear through an opening of the subject's body by a surgery.

296. A system for inserting an interface element into a subperichondral space beneath posterior cricoarytenoid muscle in order to facilitate interfacing with vocal cords in a subject, the system comprising:

a needle having a hollow inner area adapted so that the interface element can be inserted through the needle, the needle having a curve that allows the needle to move around cartilage so that the hollow needle is seen from outside of a body of the subject.

297. The system according to claim 296, wherein the needle is inserted into the subperichondral space beneath the posterior cricoarytenoid muscle and into cartilage from a back side of a larynx.

298. The system according to claim 296, further comprising the interface element.
299. The system according to claim 296, wherein the interface element includes at least one of an electrical stimulation electrode, an electrical recording electrode, a catheter to transport liquids, and a catheter for release of drugs.
300. The system according to claim 296, wherein the hollow needle is adapted to be inserted endoscopically.
301. A system according to one of claims 296-300, wherein the hollow needle seen from outside of the body appears through an opening of the subject's body by a surgery.

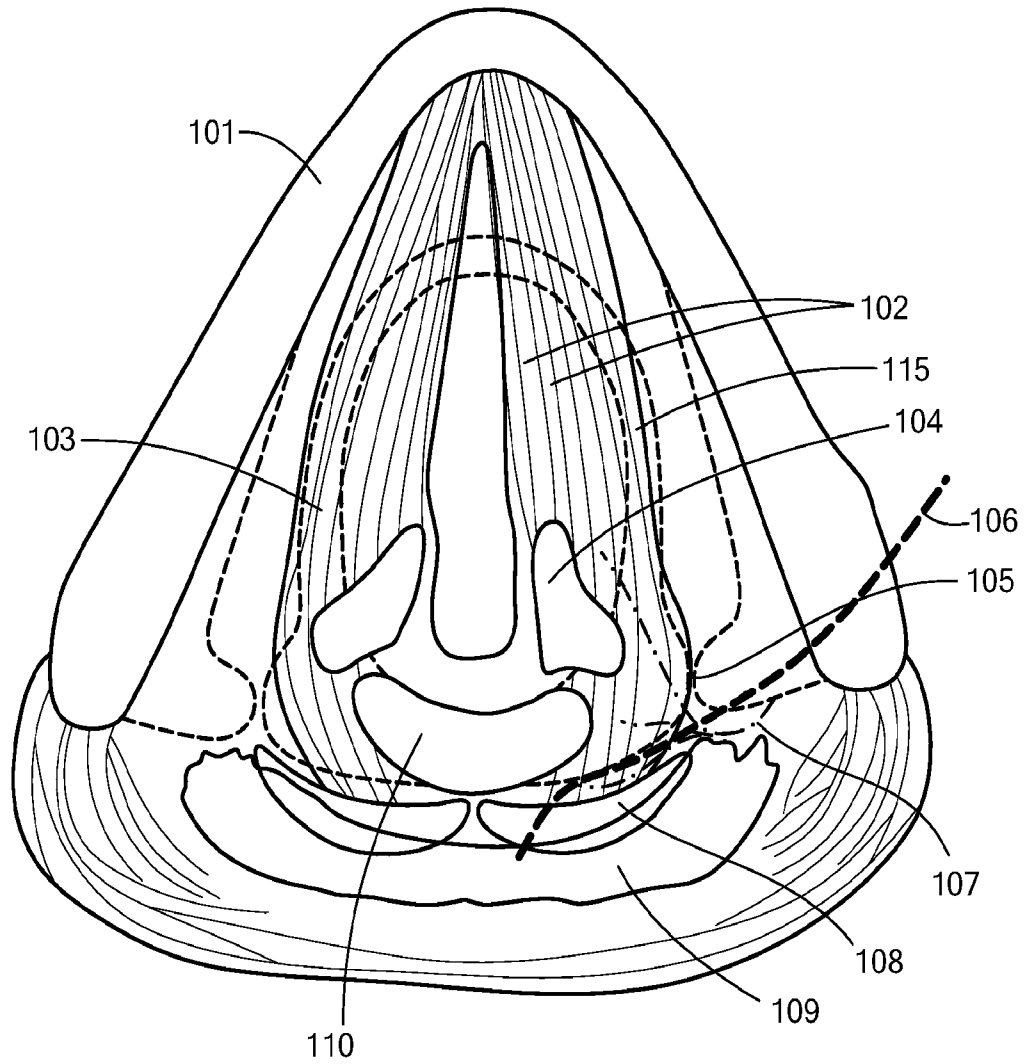

FIG. 1

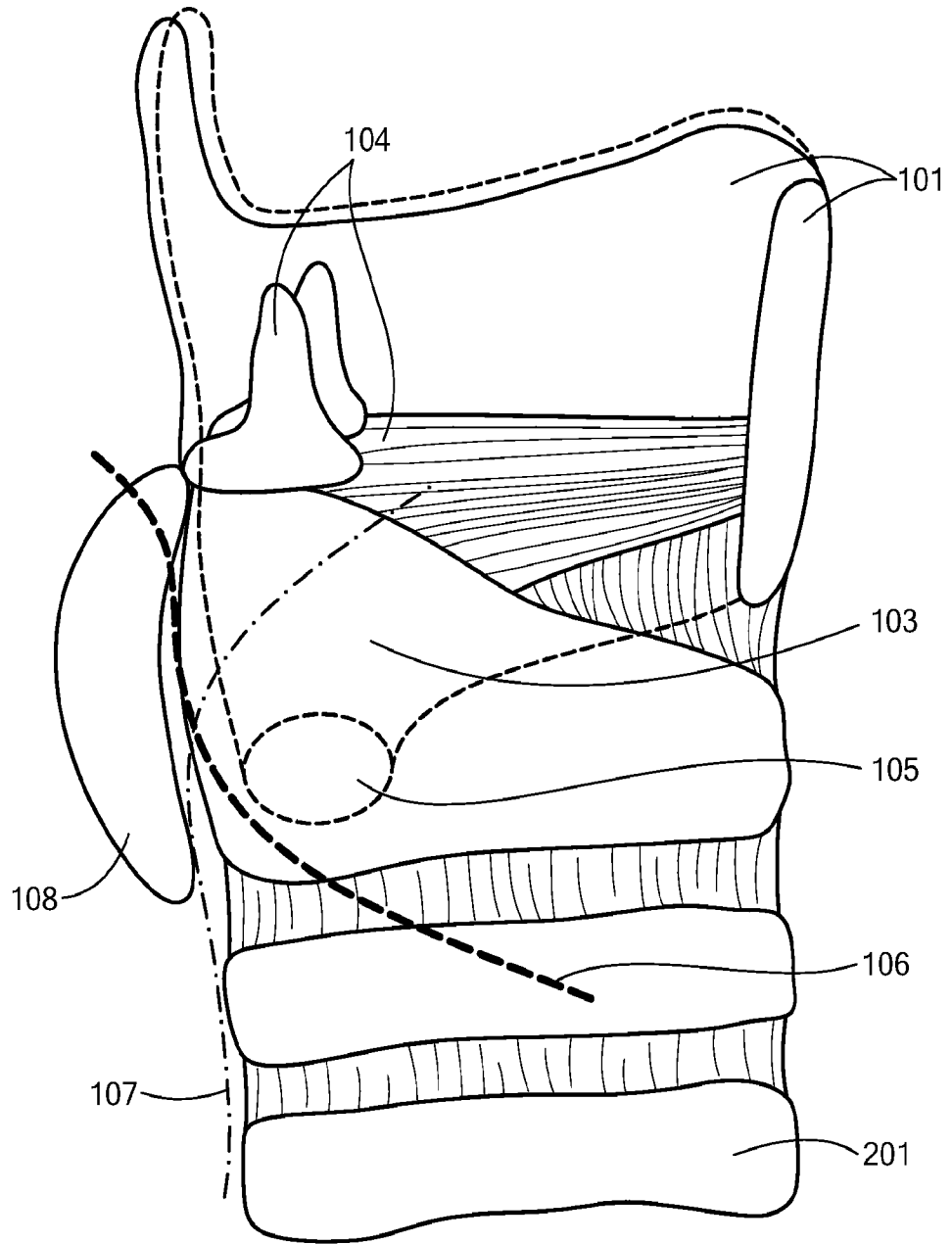

FIG. 2

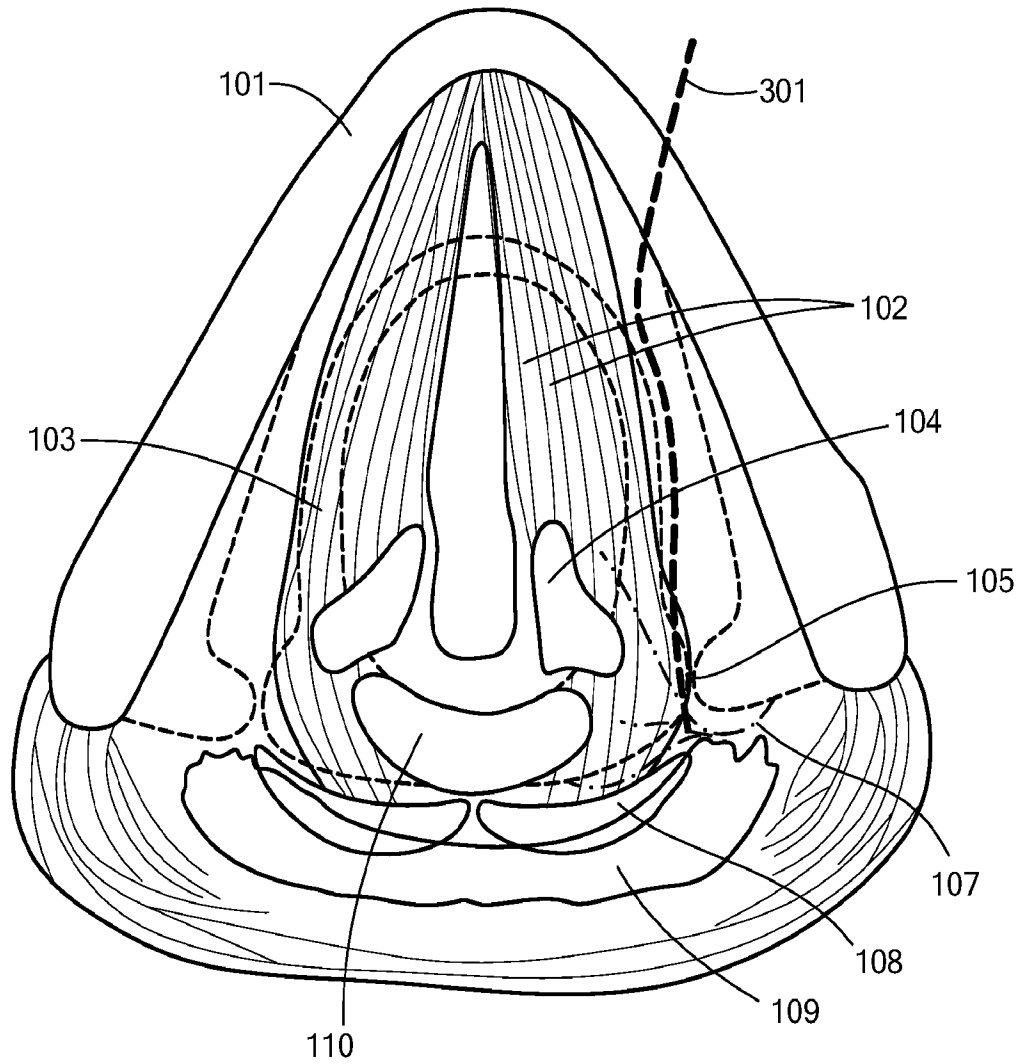

FIG. 3

4/27

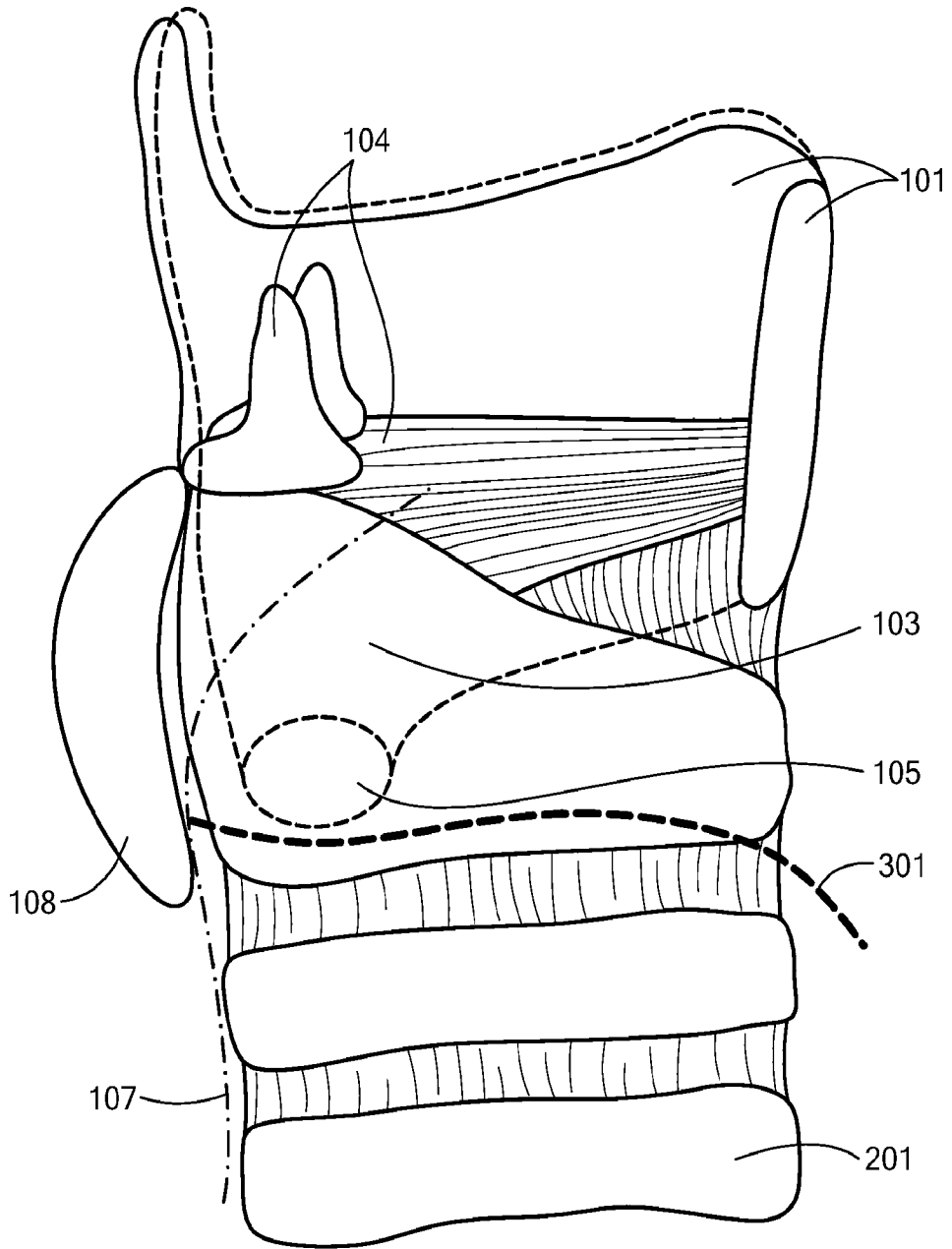

FIG. 4

5/27

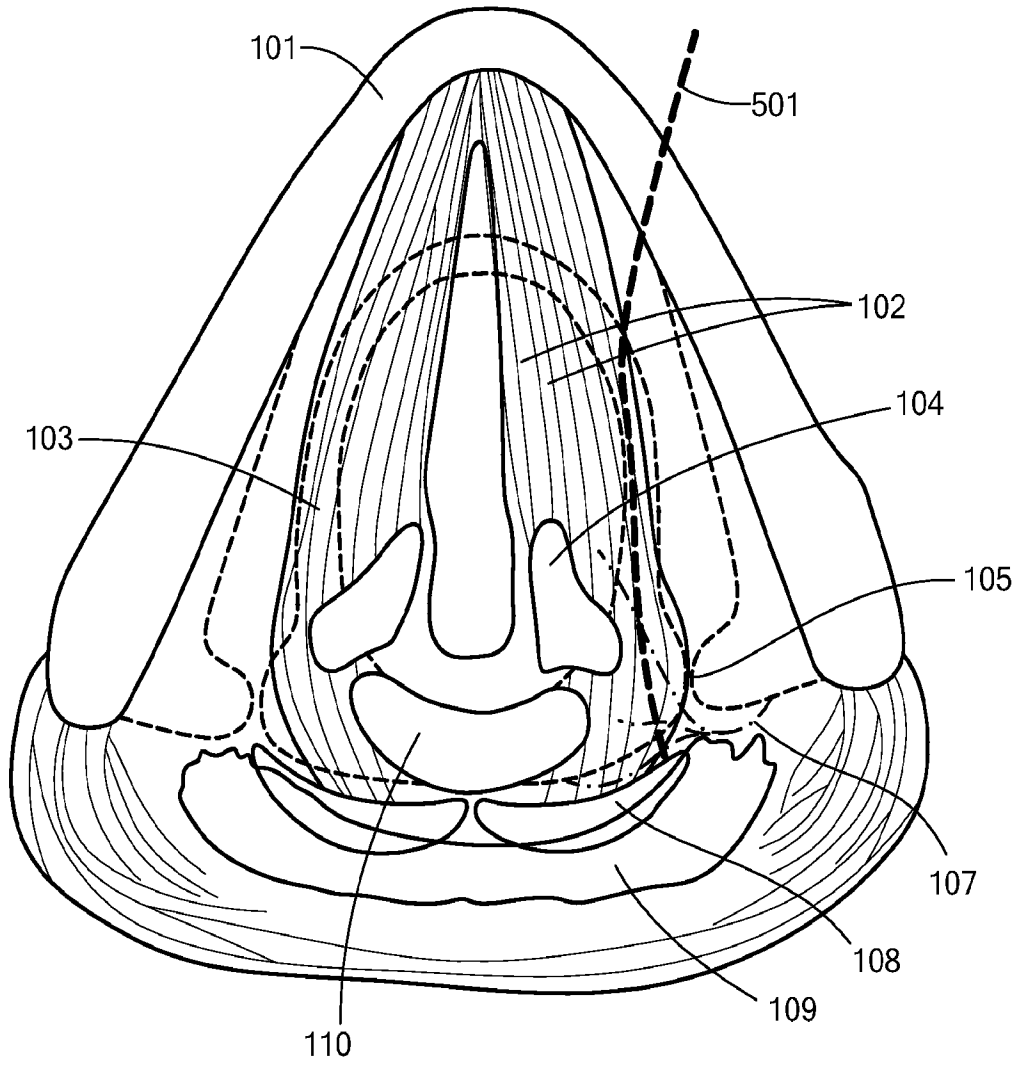

FIG. 5

6/27

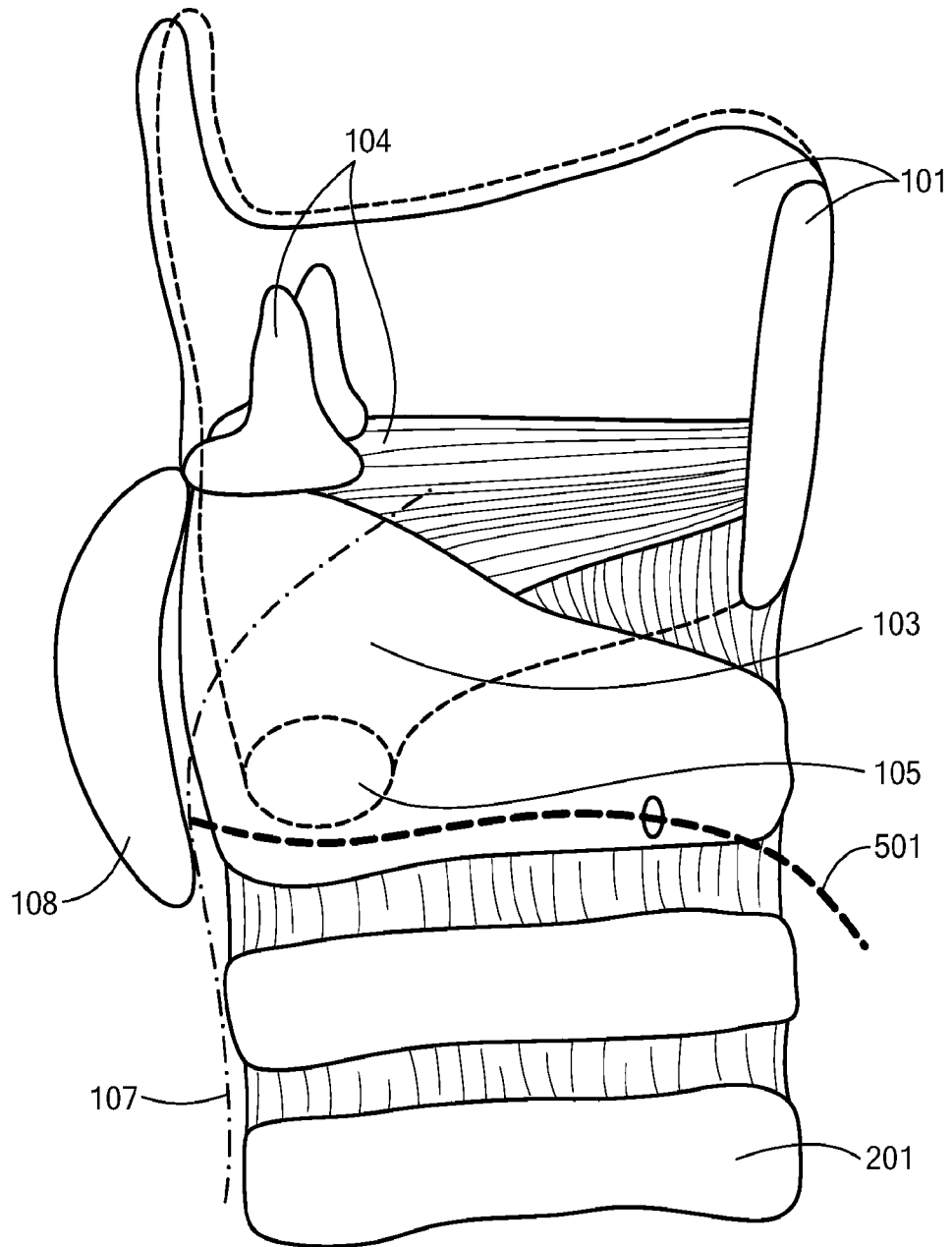

FIG. 6

7/27

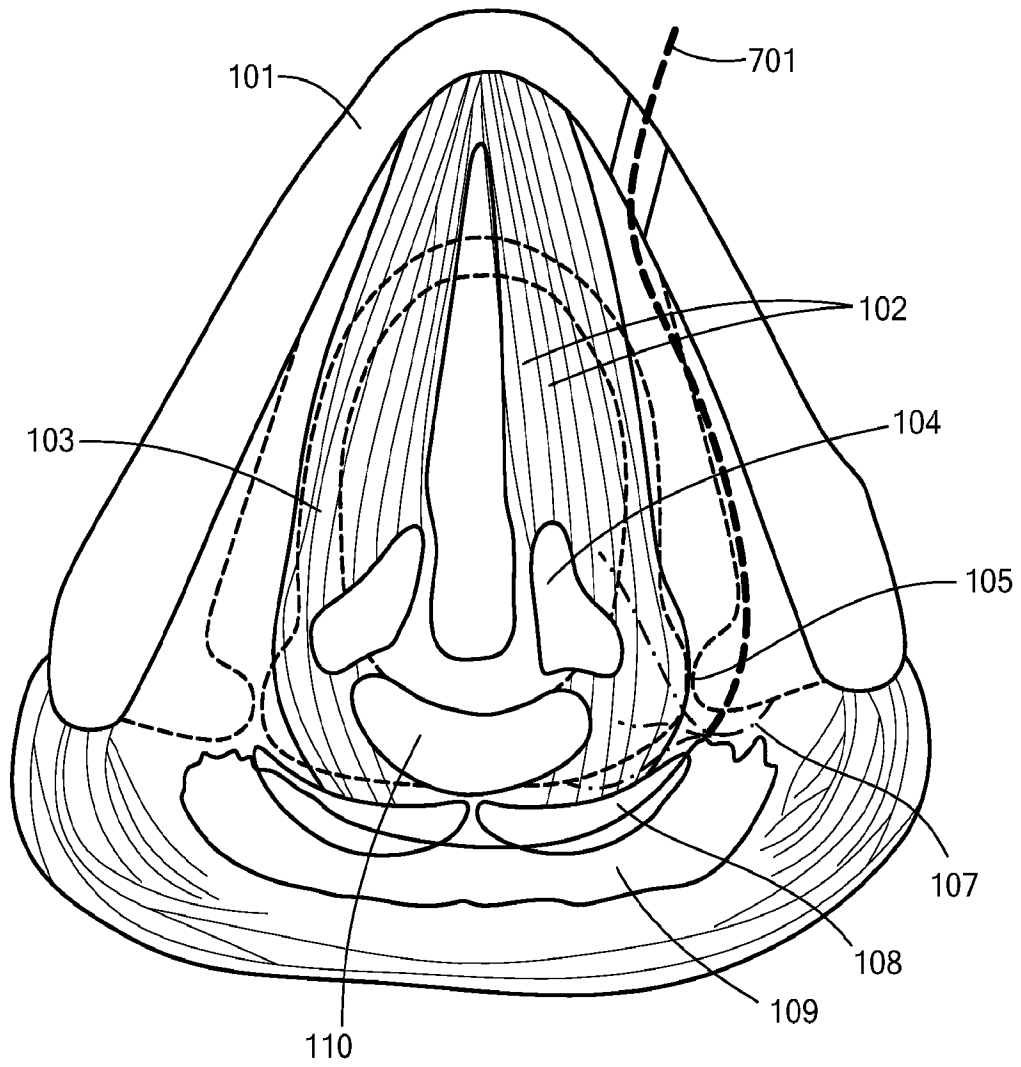

FIG. 7

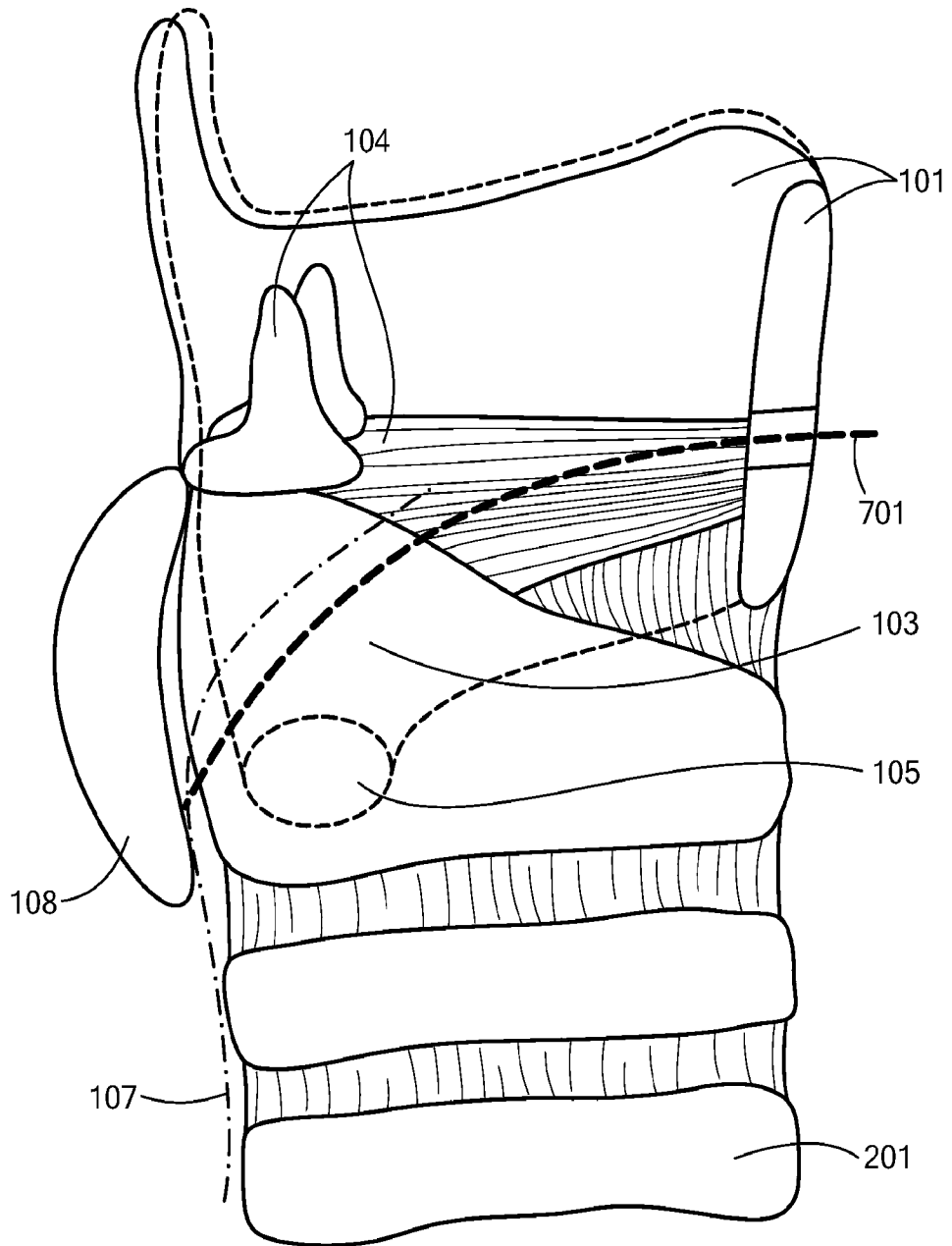

FIG. 8

9/27

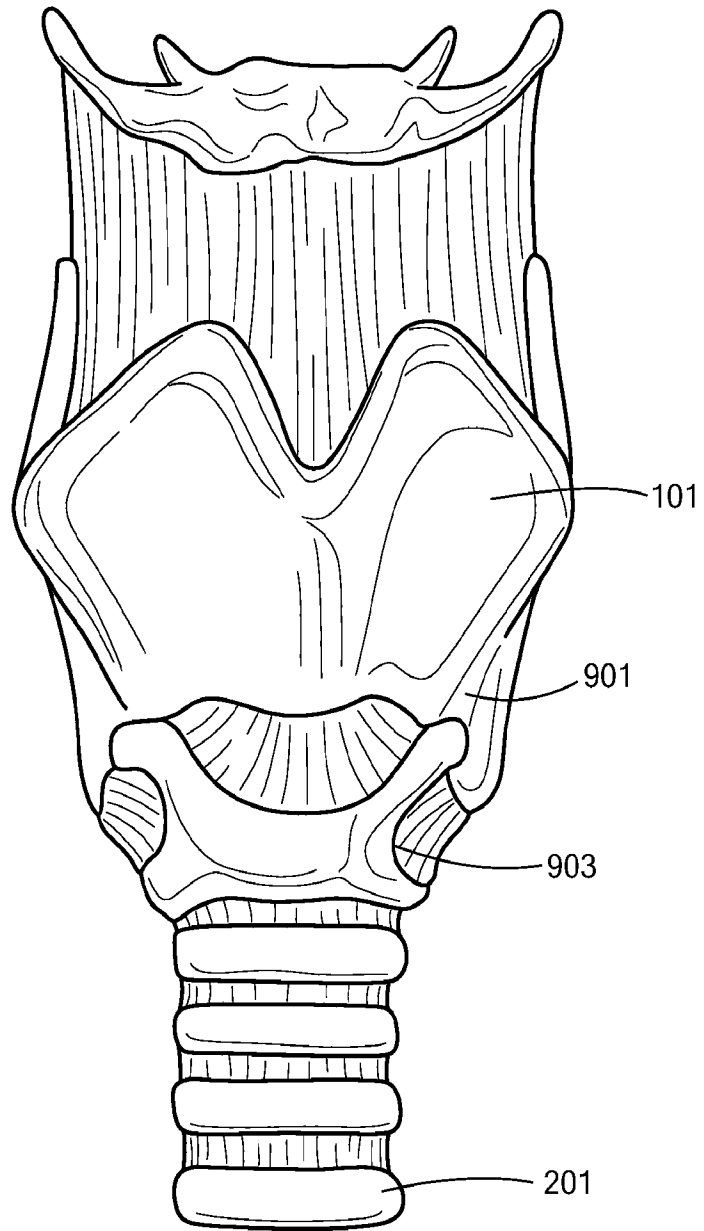

FIG. 9

10/27

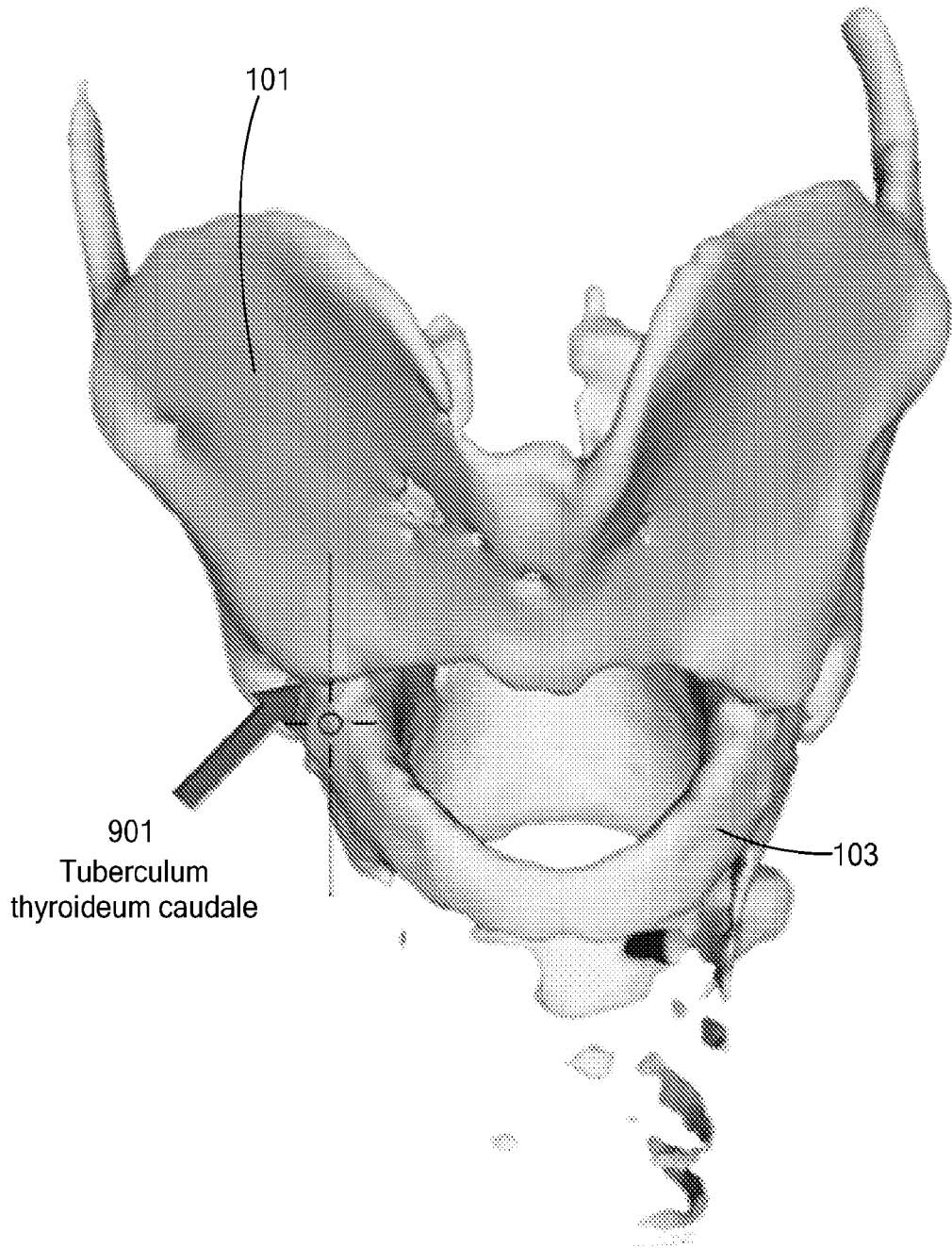

FIG. 10

11/27

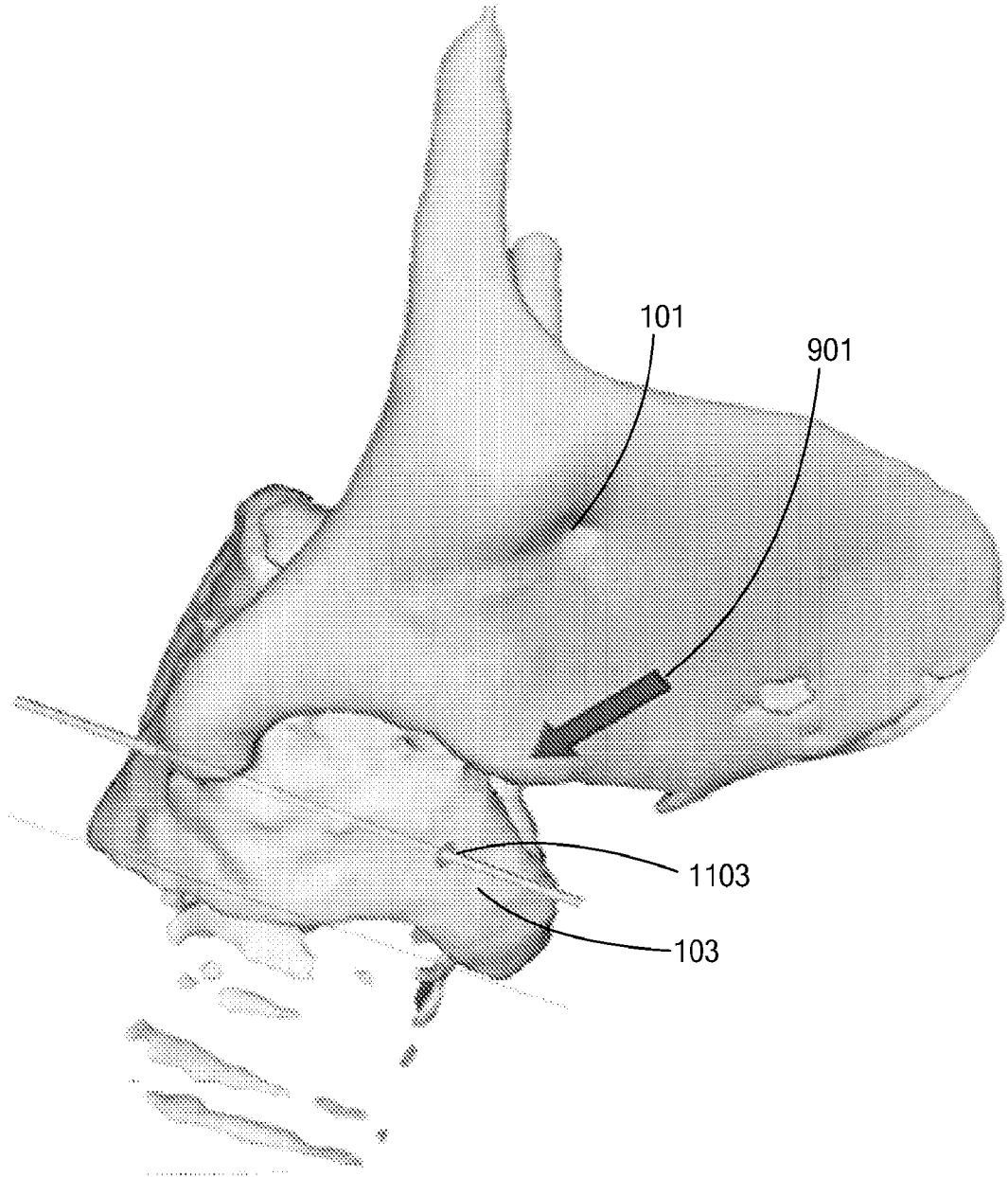

FIG. 11

12/27

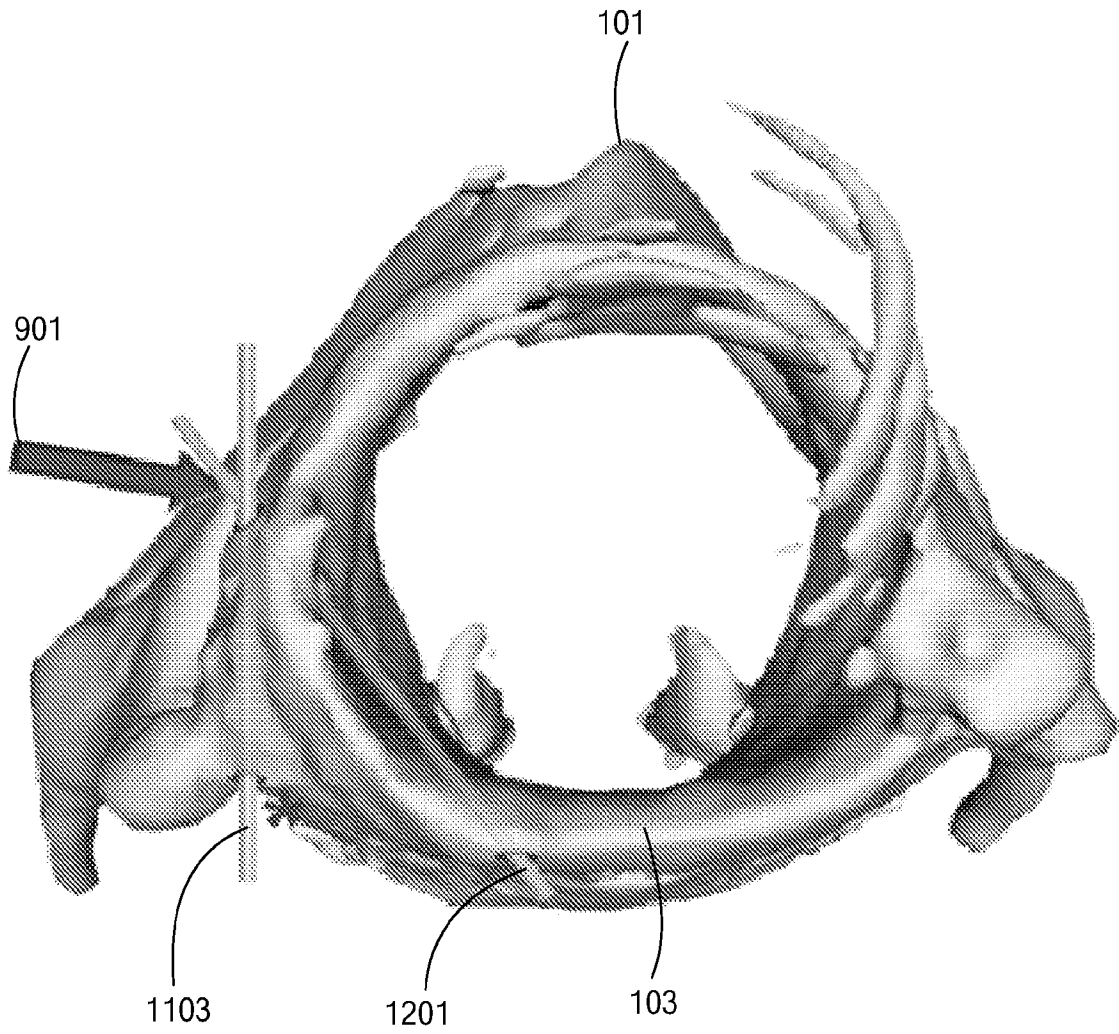

FIG. 12

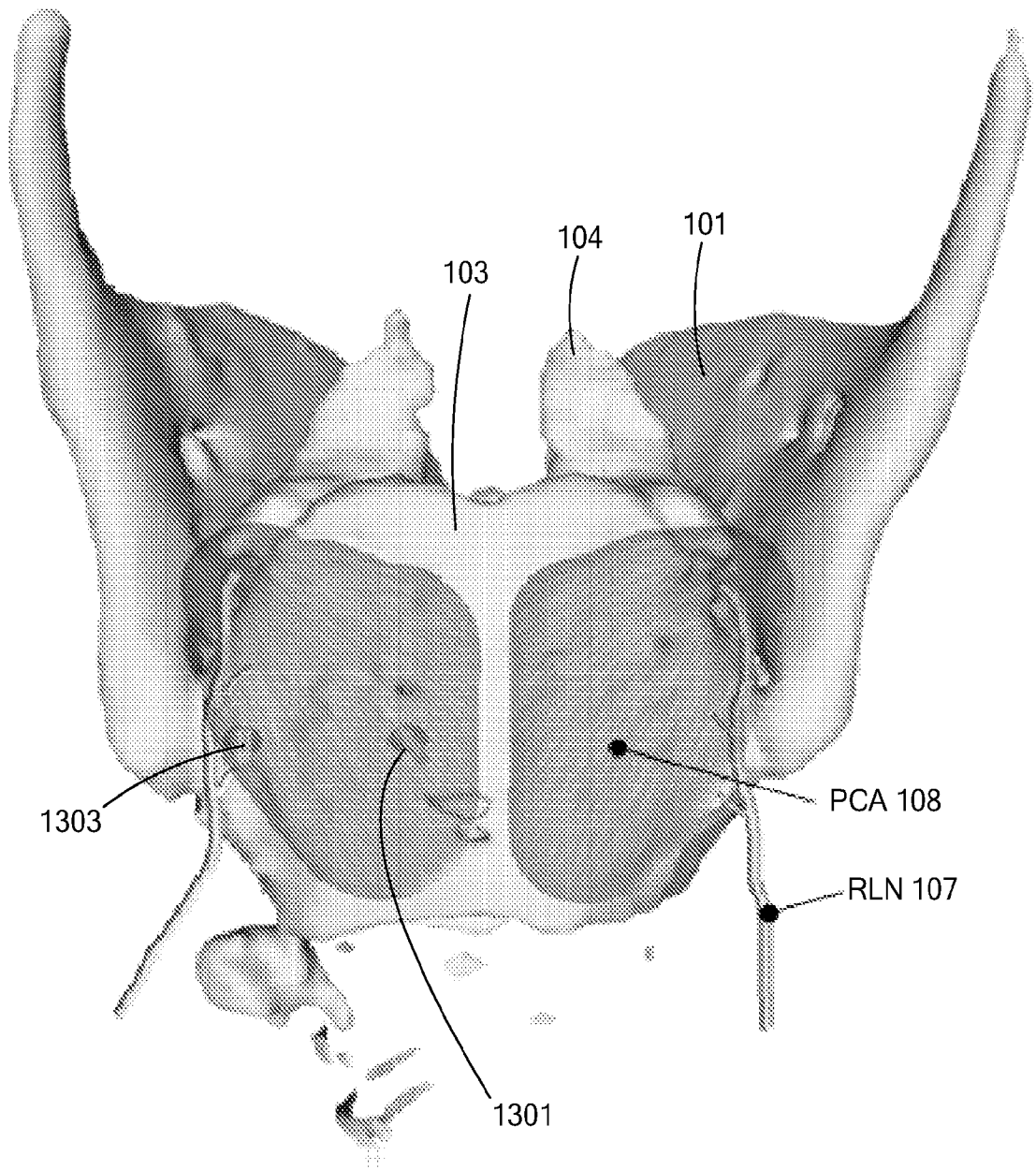

FIG. 13

14/27

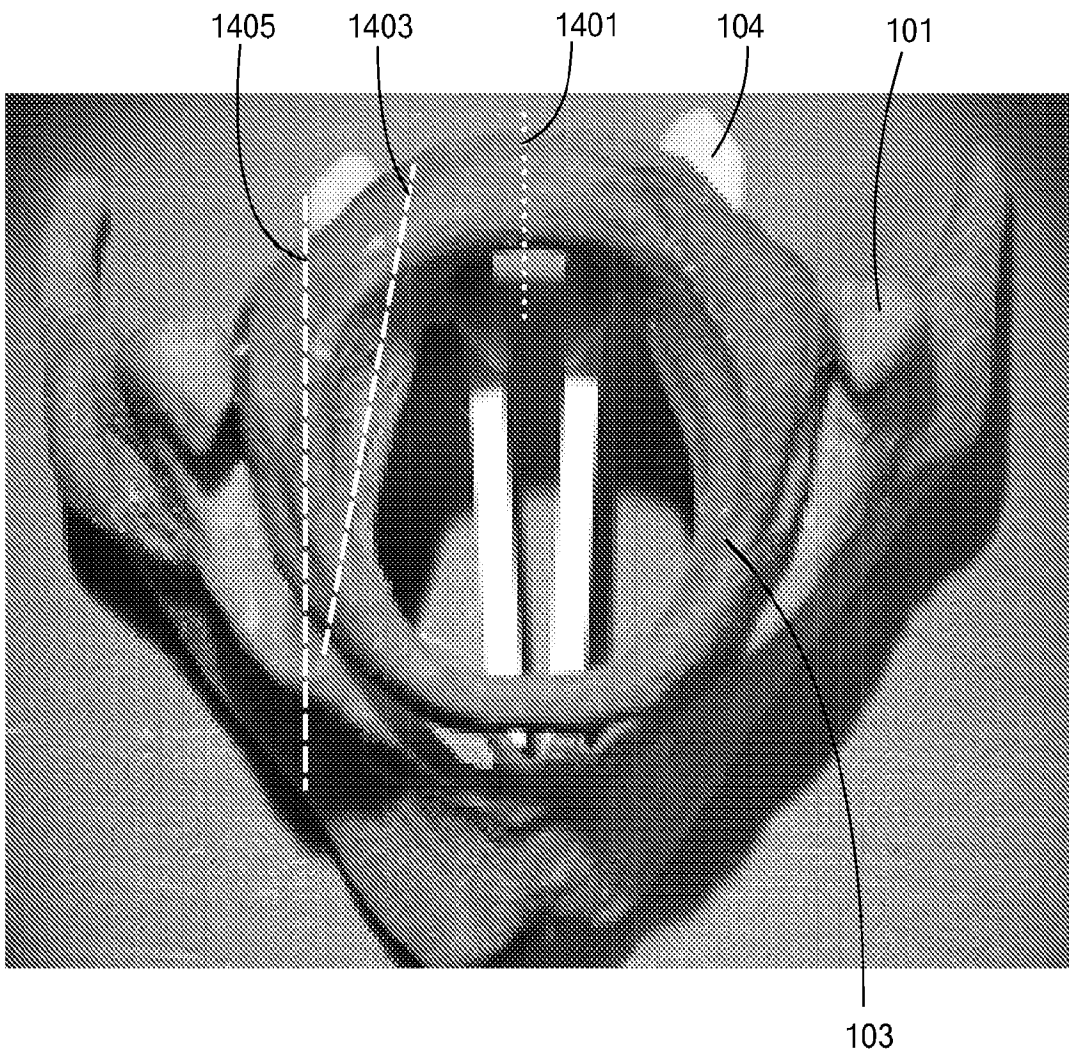

FIG. 14

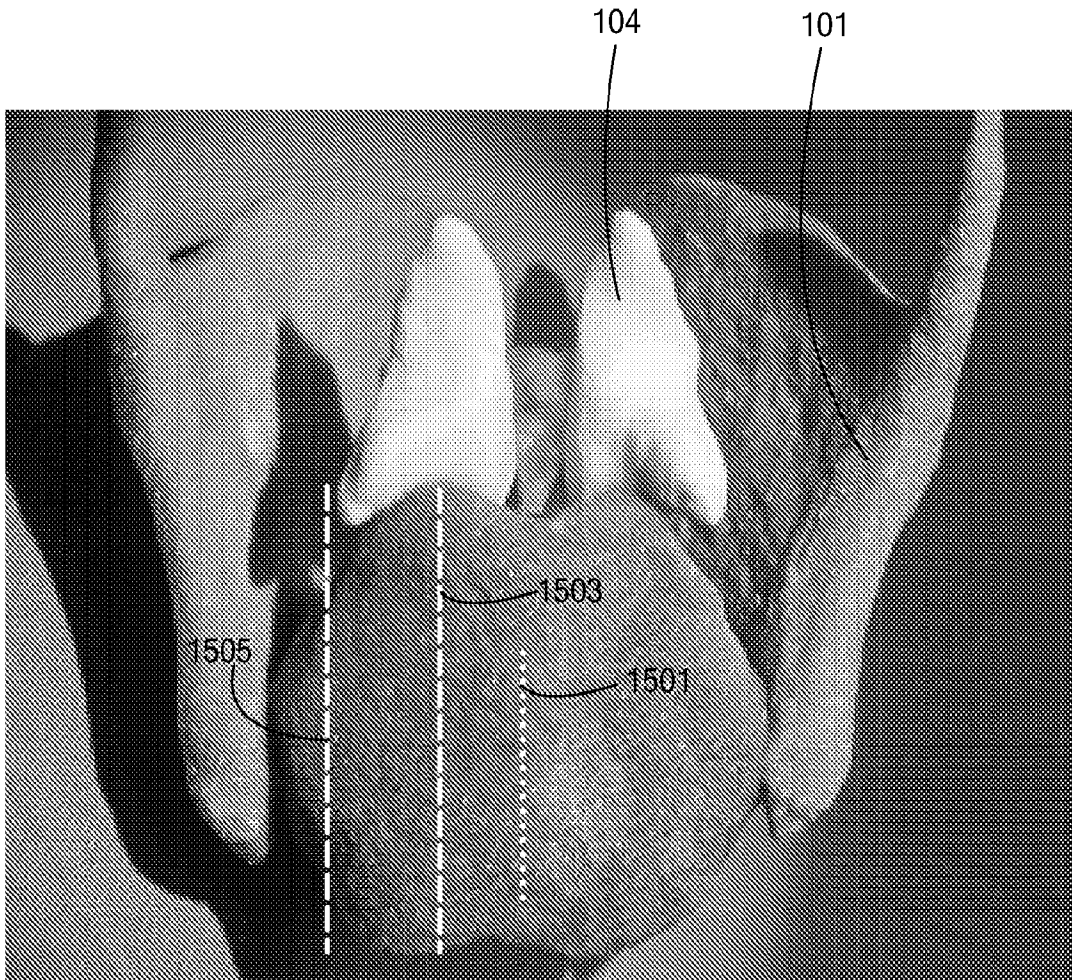

FIG. 15

16/27

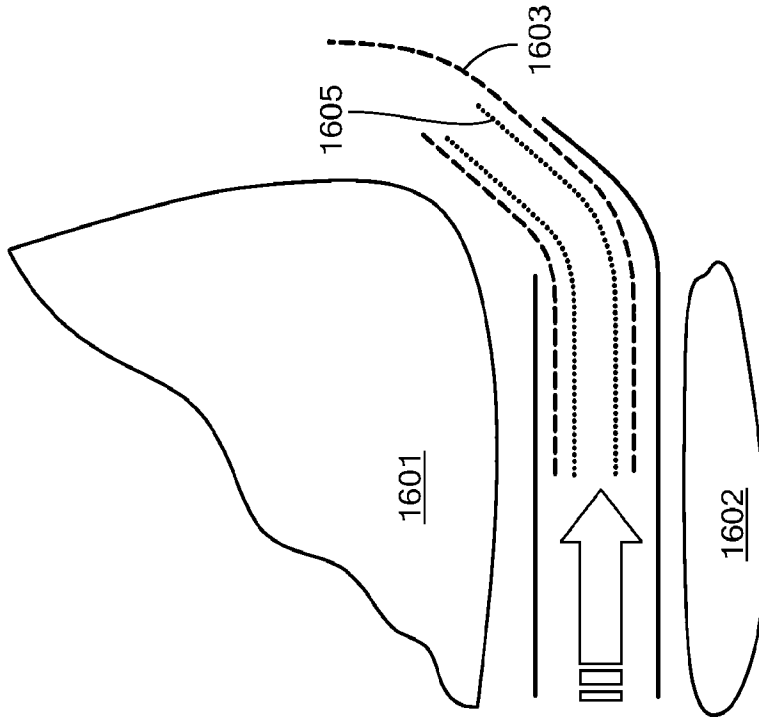

FIG. 16B

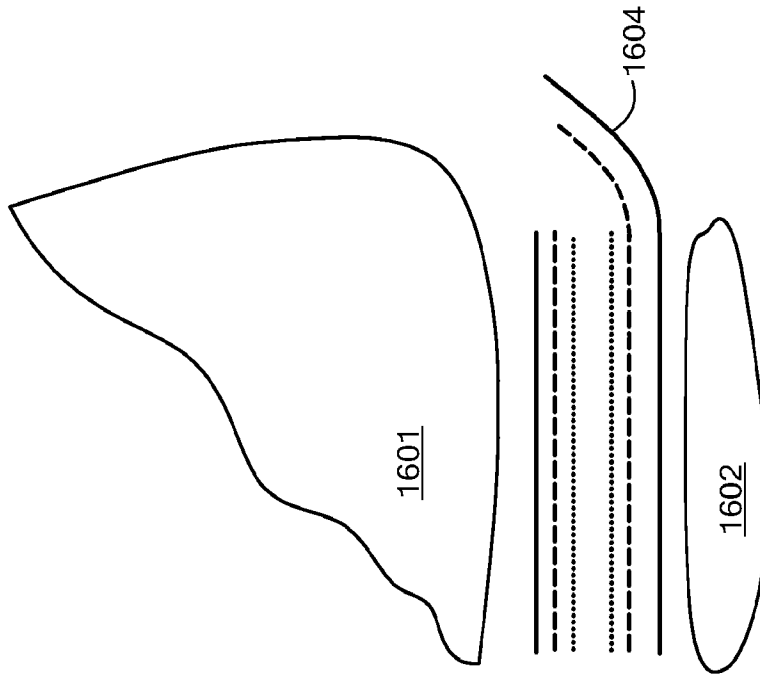

FIG. 16A

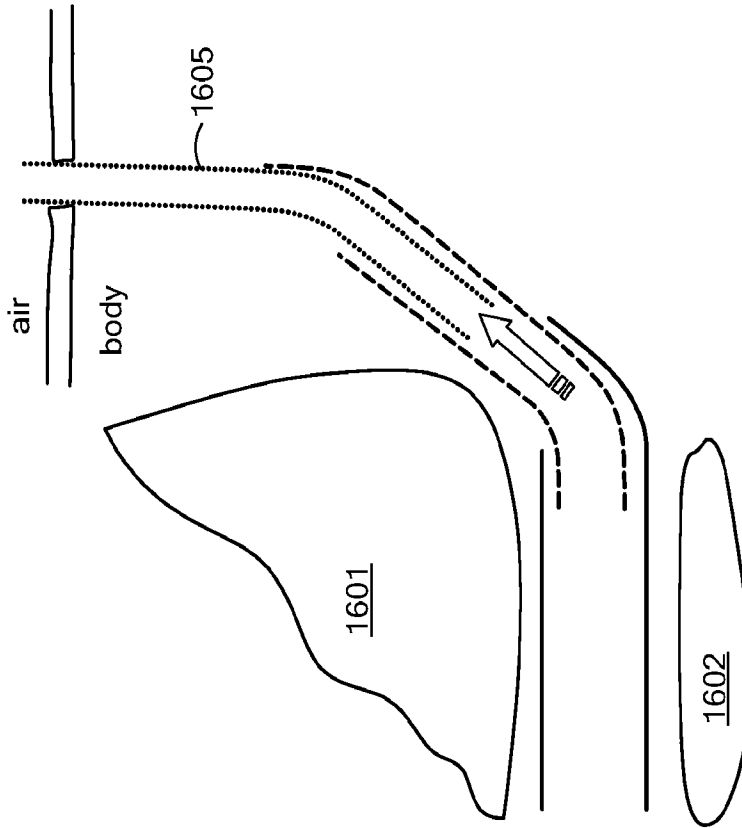

FIG. 16D

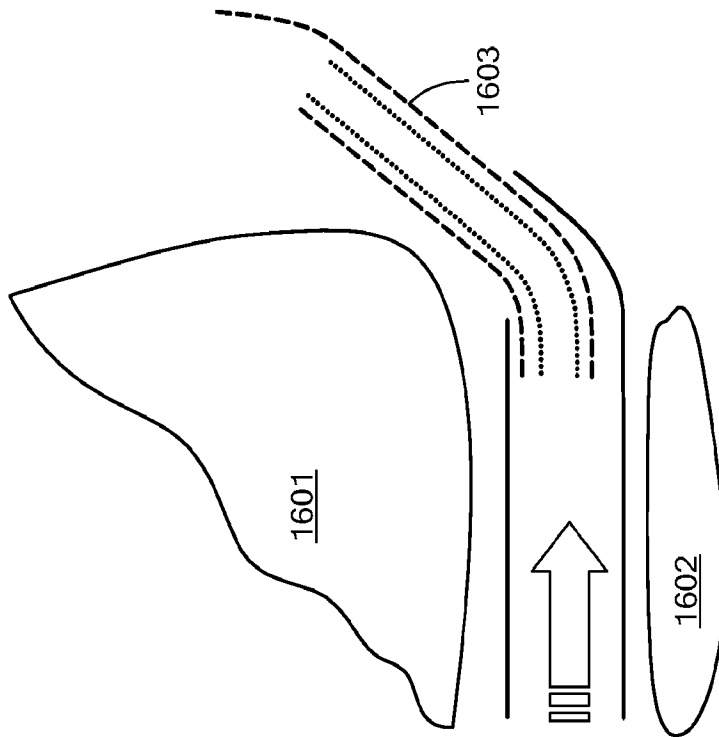

FIG. 16C

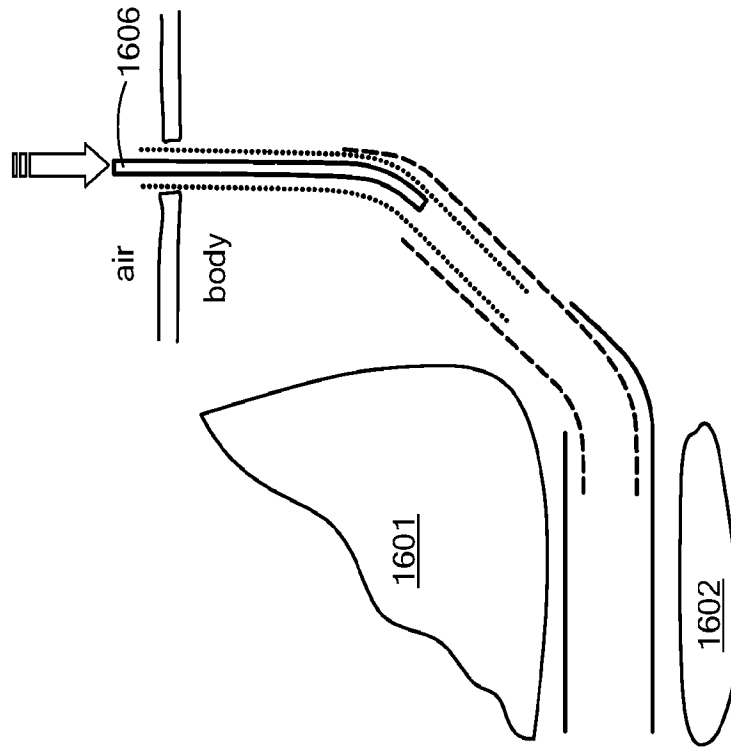

FIG. 16F

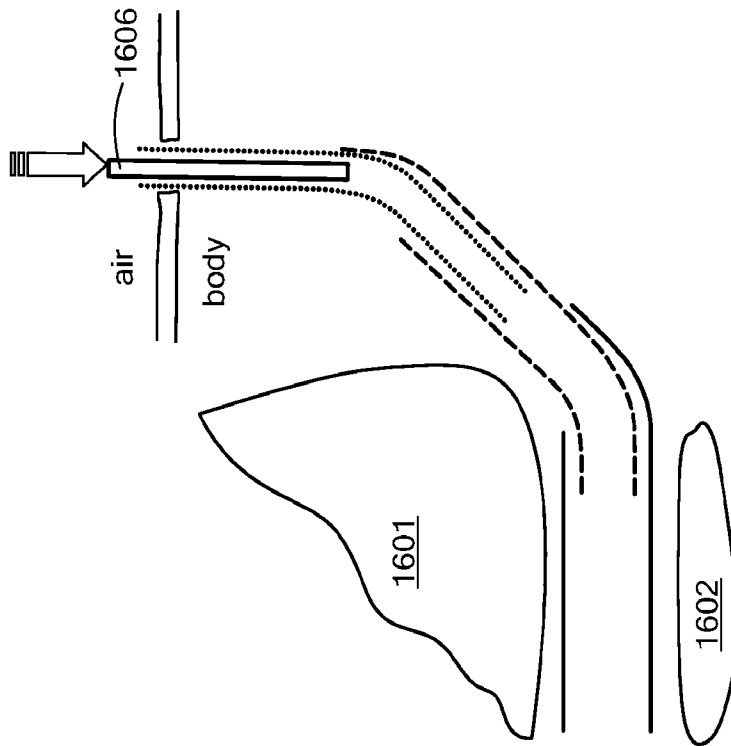

FIG. 16E

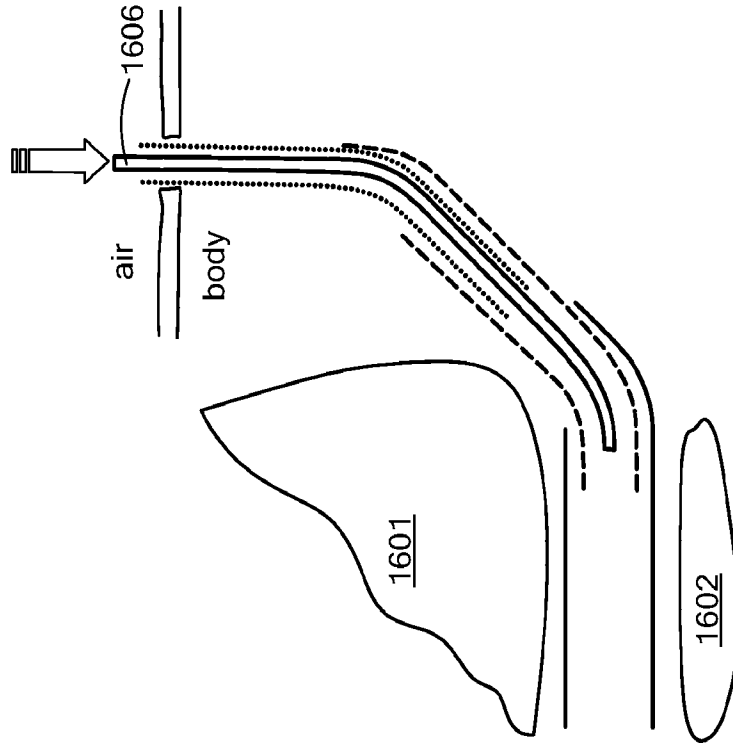

FIG. 16H

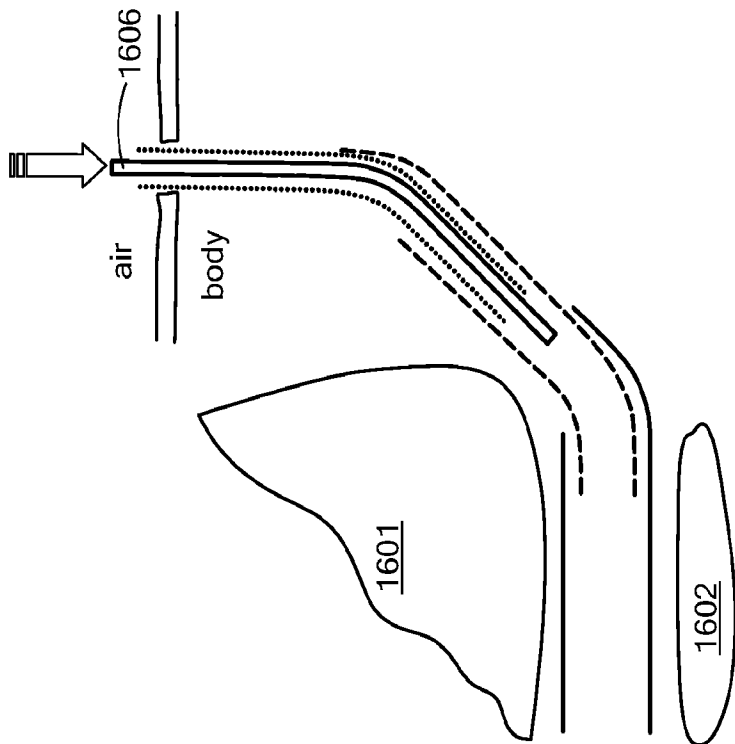

FIG. 16G

20/27

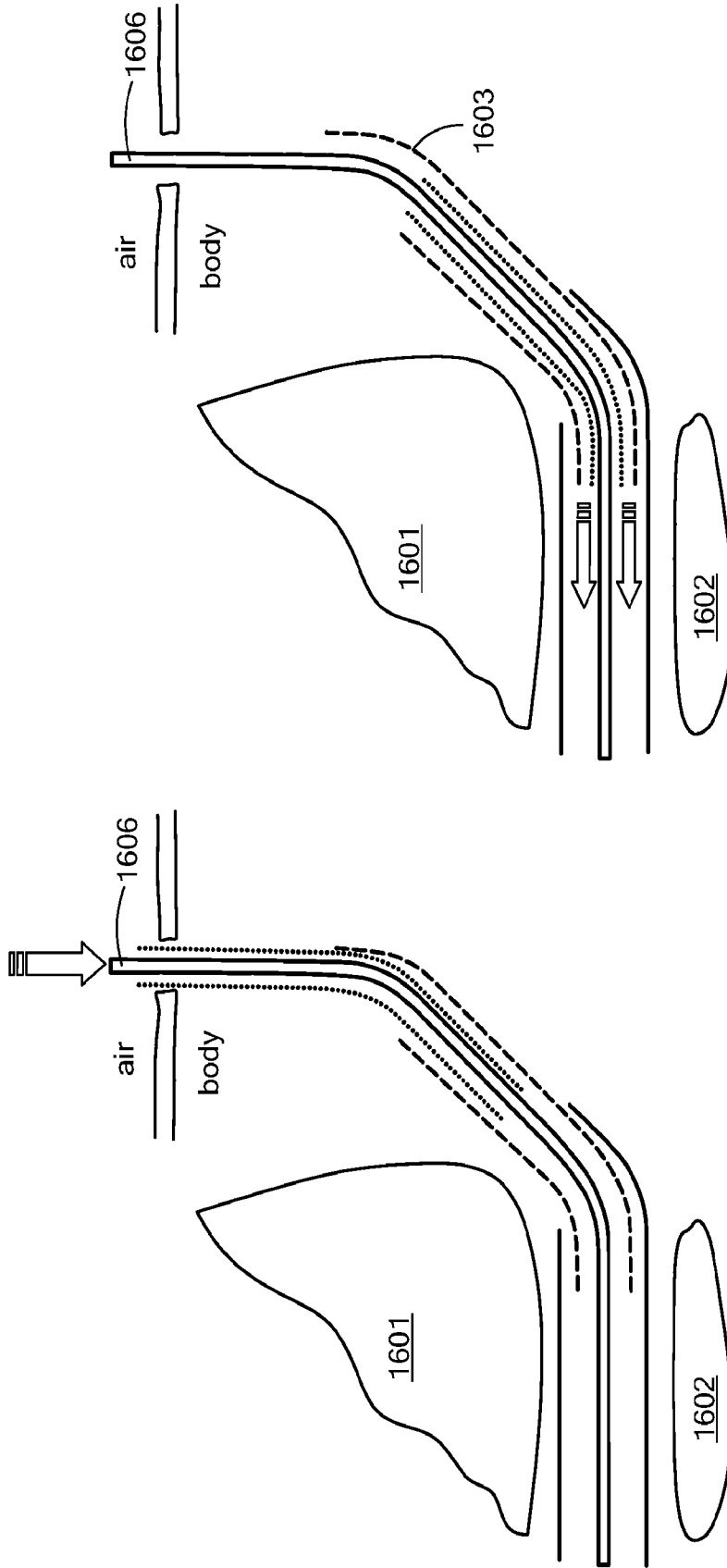

FIG. 16J

FIG. 16I

21/27

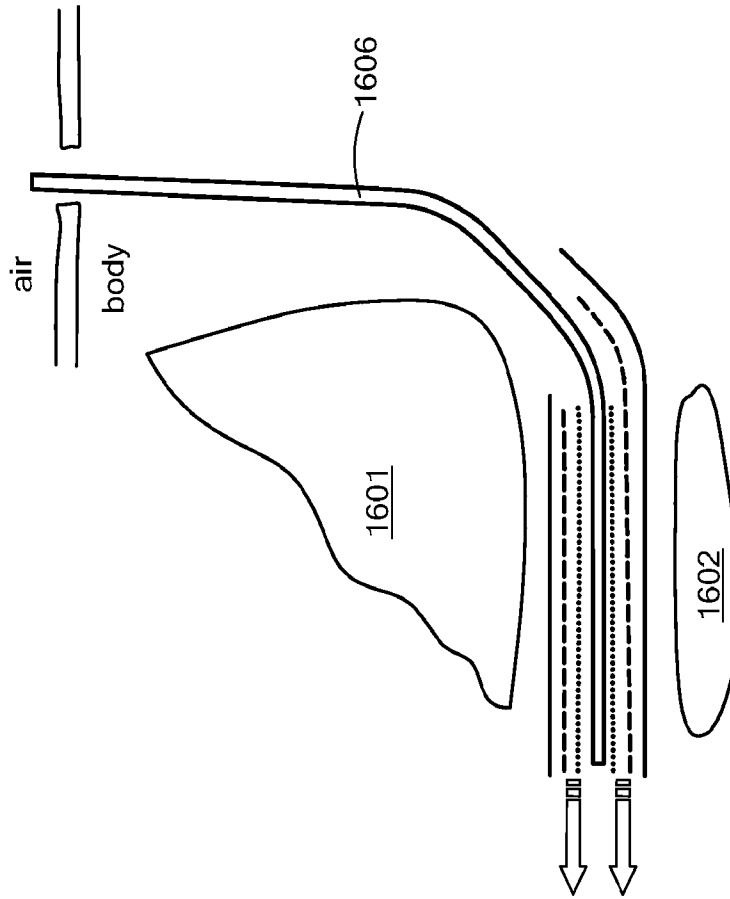

FIG. 16L

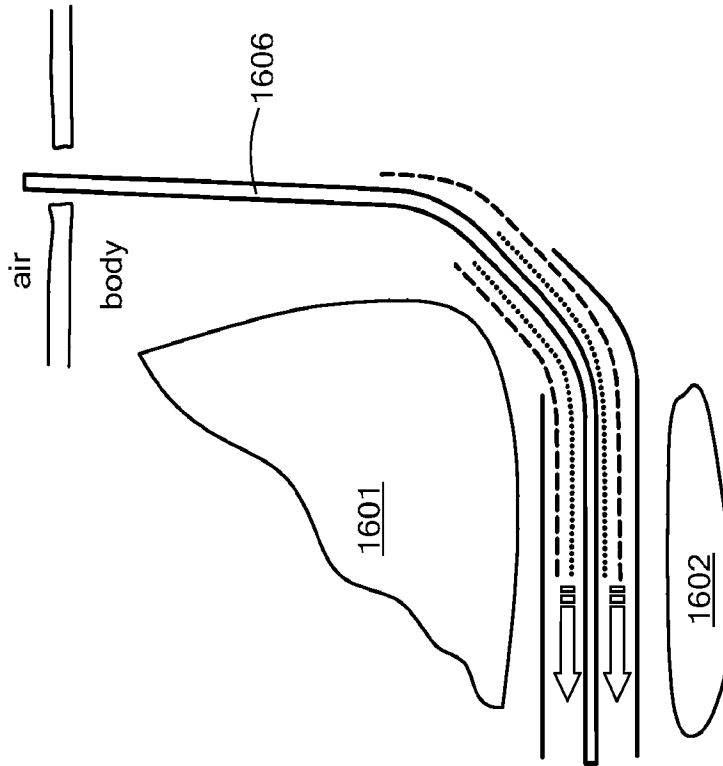

FIG. 16K

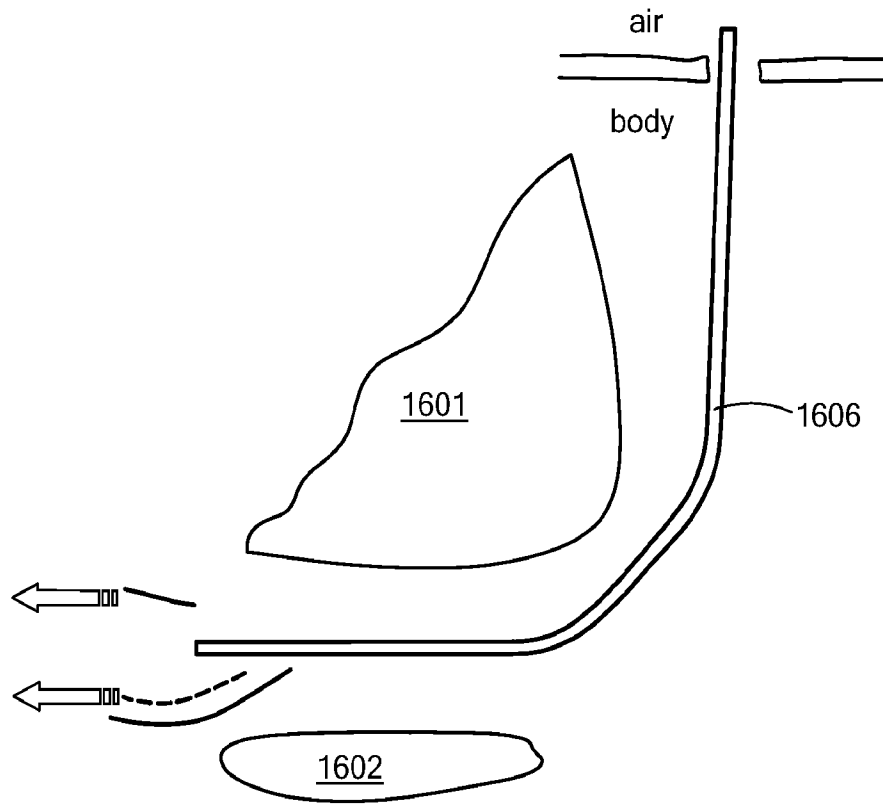

FIG. 16M

23/27

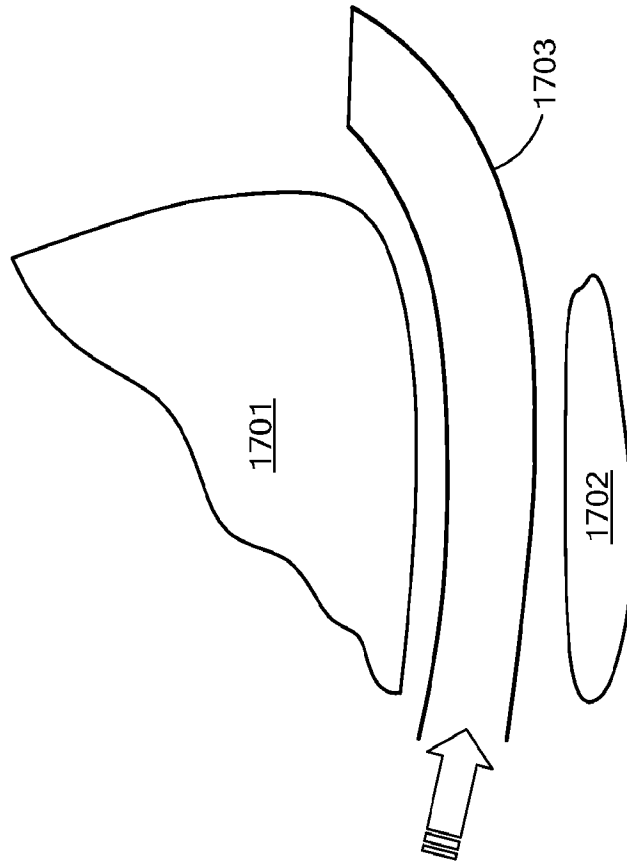

FIG. 17B

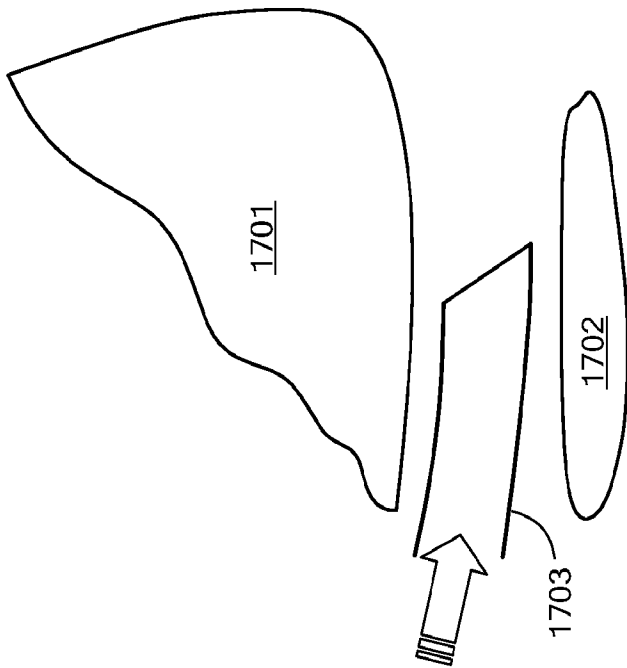

FIG. 17A

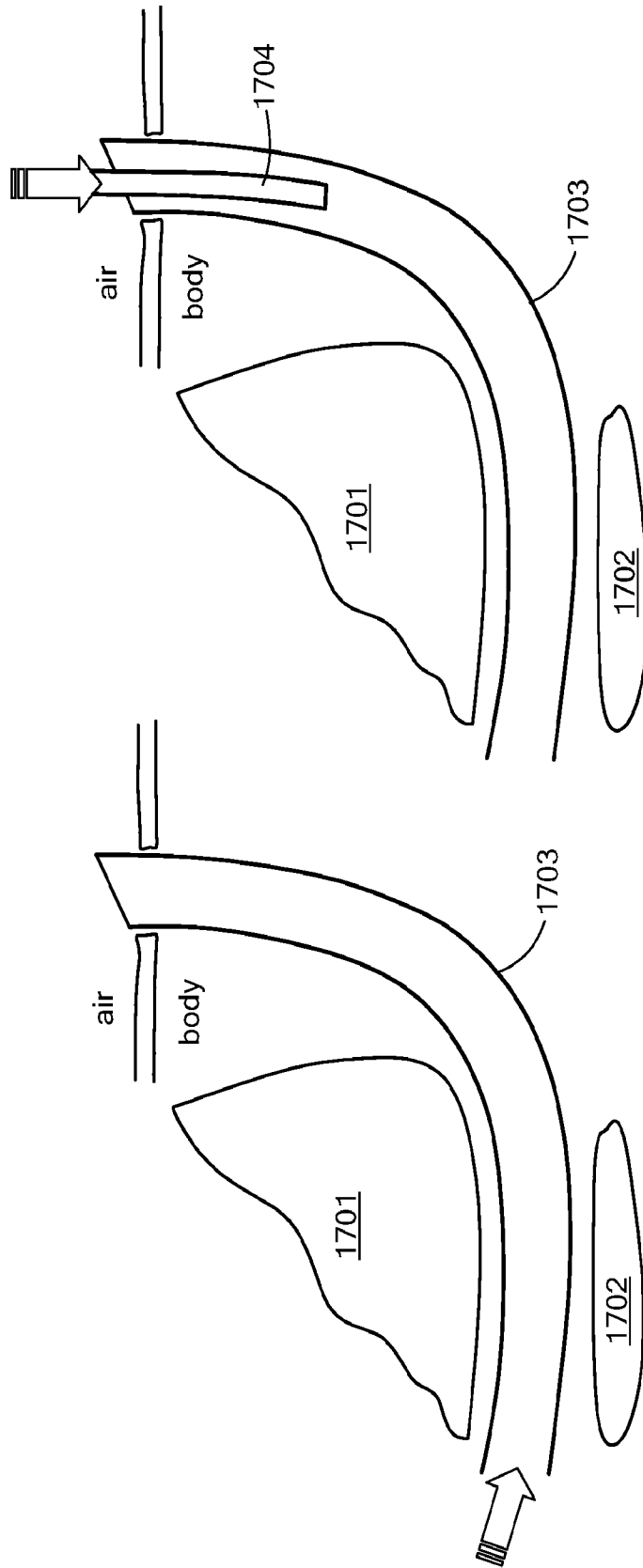

FIG. 17D

FIG. 17C

25/27

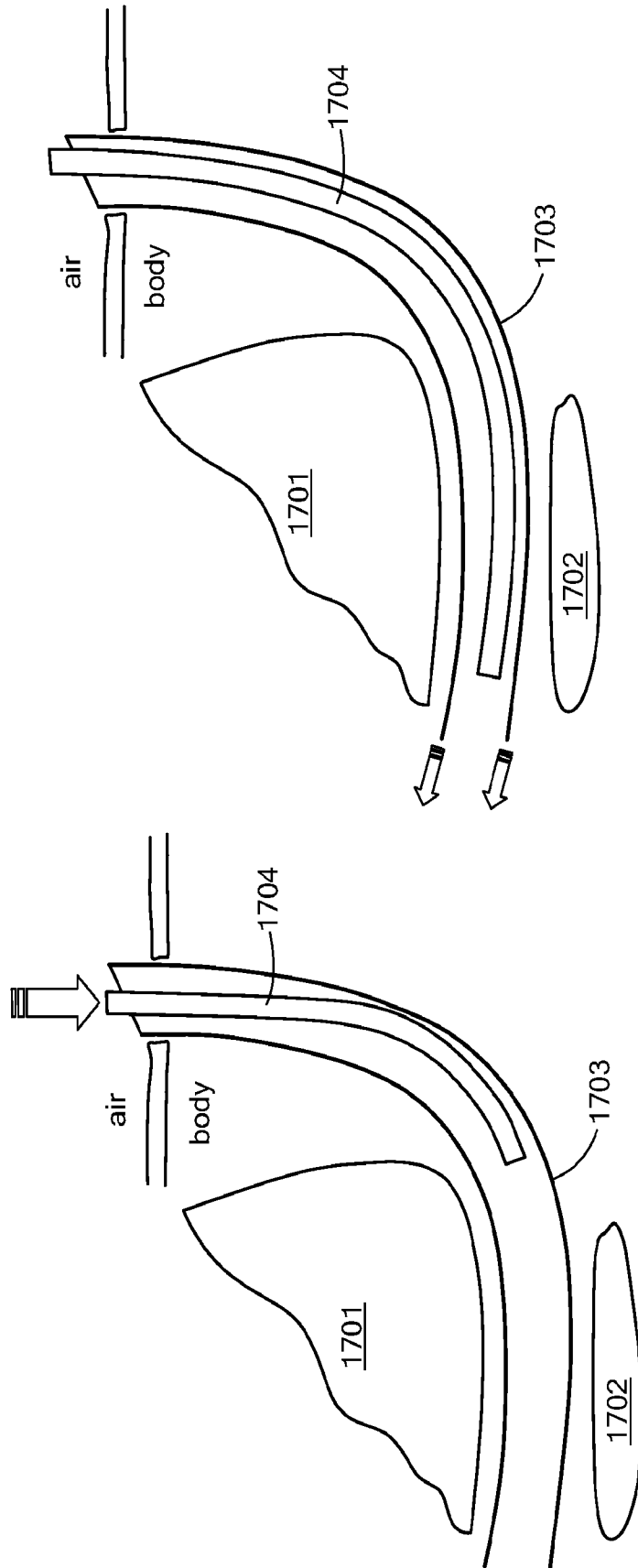

FIG. 17F

FIG. 17E

26/27

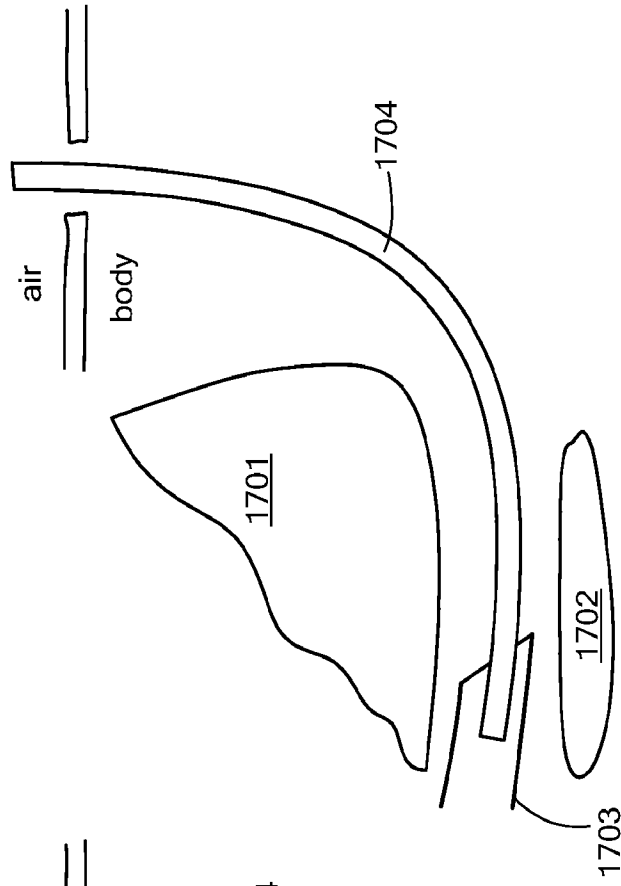

FIG. 17H

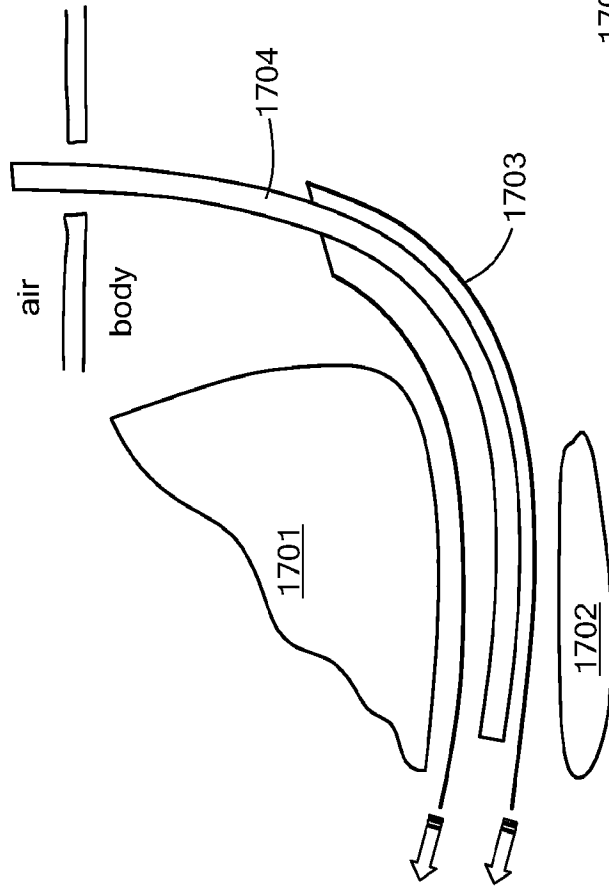

FIG. 17G

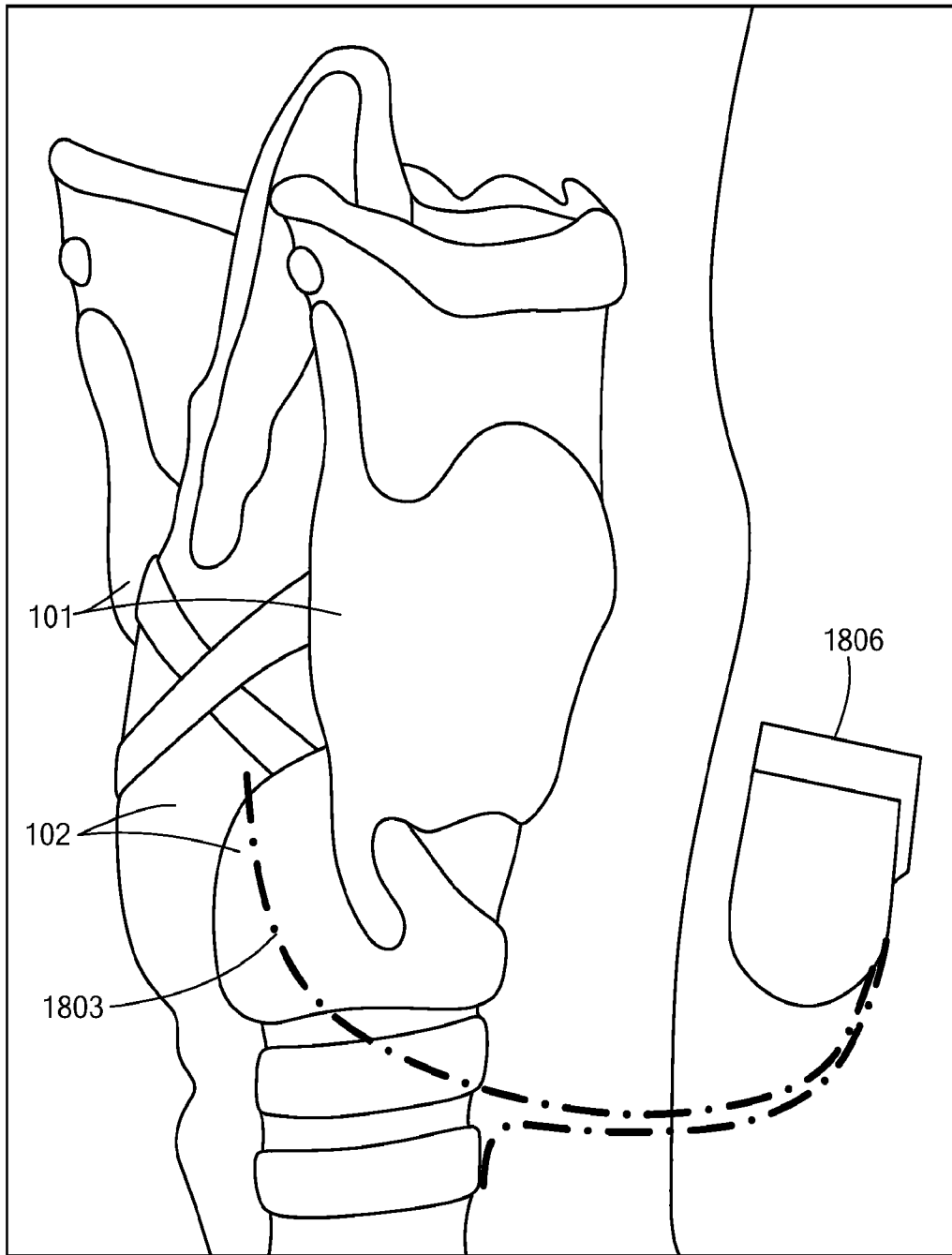

FIG. 18