

J. C. PETERS.
TUB FOR WASHING MACHINES.

APPLICATION FILED JULY 22, 1903.

2 SHEETS—SHEET 1.

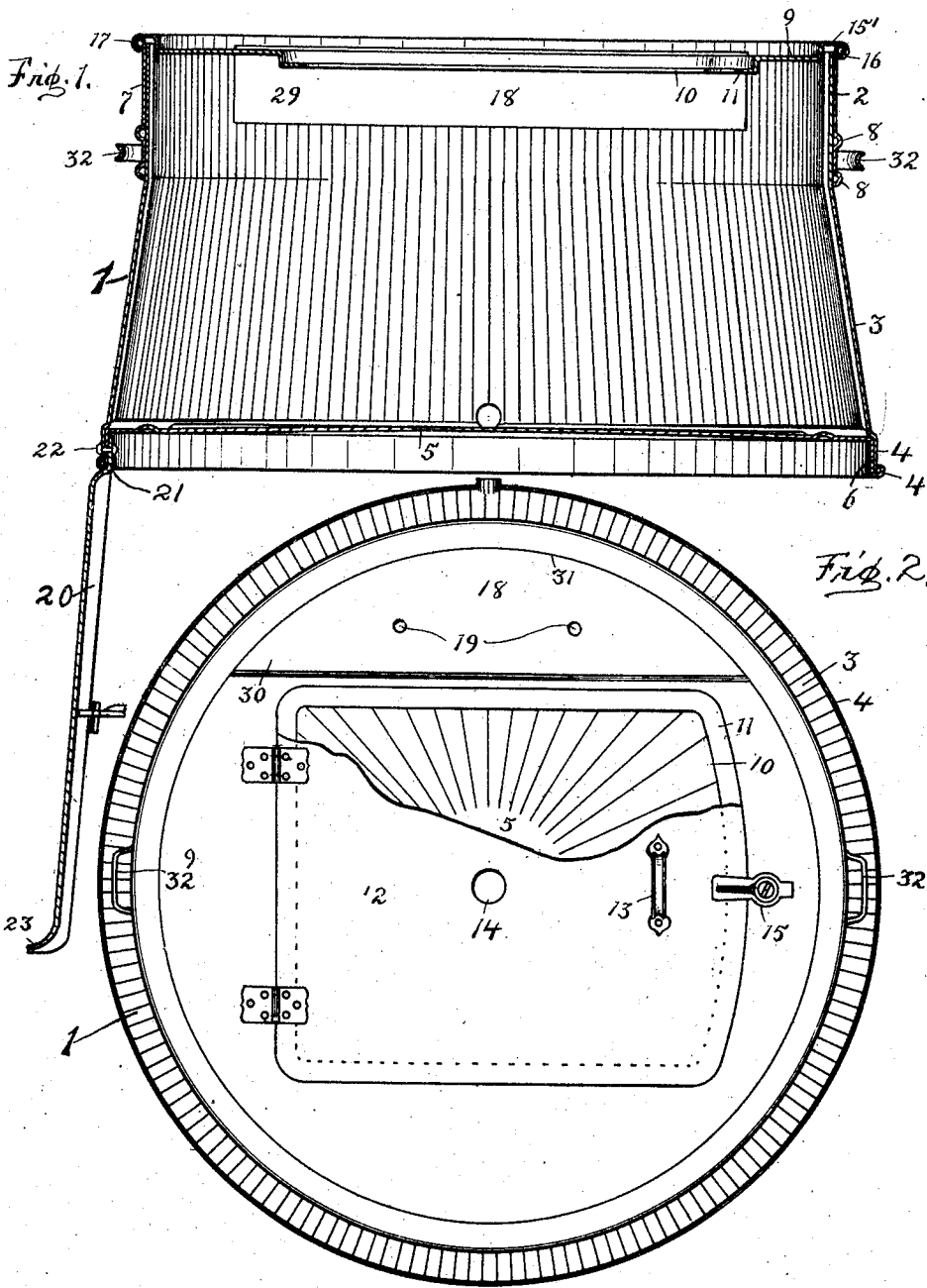

WITNESSES:
A. E. Burns
Augusta Viberg.

John C. Peters INVENTOR
Chapin & Denny
 Attorneys.

J. C. PETERS.
TUB FOR WASHING MACHINES.

APPLICATION FILED JULY 22, 1903.

2 SHEETS—SHEET 2.

Fig. 3.

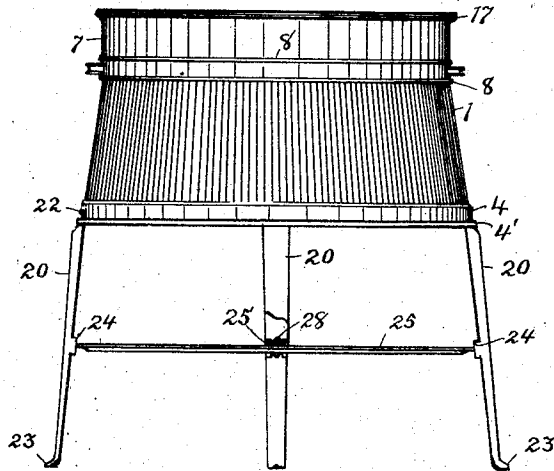

Fig. 5.

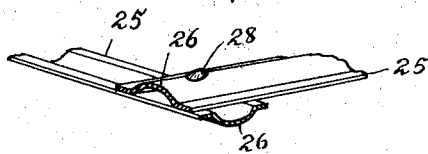

Fig. 4.

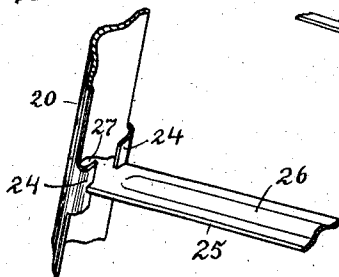
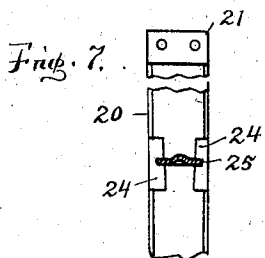
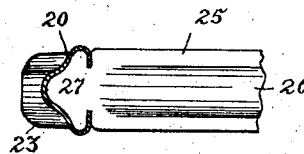

Fig. 6.



WITNESSES:

A. J. Burns
Augusta Viberg.

John C. Peters INVENTOR

BY *Chapin & Denny*

Attorneys.

UNITED STATES PATENT OFFICE.

JOHN C. PETERS, OF FORT WAYNE, INDIANA.

TUB FOR WASHING-MACHINES.

SPECIFICATION forming part of Letters Patent No. 780,910, dated January 24, 1905.

Application filed July 22, 1903. Serial No. 166,514.

To all whom it may concern:

Be it known that I, JOHN C. PETERS, a citizen of the United States, residing at Fort Wayne, in the county of Allen, in the State of Indiana, have invented certain new and useful Improvements in Tubs for Washing-Machines; and I do hereby declare that the following is a full, clear, and exact description of the invention, which will enable others skilled in the art to which it appertains to make and use the same, reference being had to the accompanying drawings, which form part of this specification.

My invention relates to improvements in tubs or suds-boxes for washing-machines.

The object of my present invention is to provide a corrugated sheet-metal tub for hand-operated washing-machines of novel construction and provided with a novel means for imparting strength and rigidity to the detachable supporting-legs.

My invention consists of a galvanized-iron tub so corrugated upon both its inner and outer surfaces as to present an ornamental and artistic exterior design, for which an application is now pending, and a perfect interior rubbing-surface, having an improved means for uniting the top and bottom to the sides thereof and for rendering the sides perfectly rigid without the use of hoops, a new form of supporting-legs, and improved means for imparting rigidity thereto.

Similar reference-numerals in the accompanying drawings indicate like parts throughout the several views, in which—

Figure 1 is a view of my invention in vertical central section taken through the handles and one of the supporting-legs with the lid omitted and showing the construction of the reinforced corrugated sides and the manner of uniting the top and bottom thereto. Fig. 2 is a plan view of the same, showing the lid closed and broken away in part and also showing the soap receptacle or recess. Fig. 3 is a side elevation of my invention with one of the supporting-legs broken away in part and one of the braces therefor in cross-section to show the manner of uniting these braces.

Fig. 4 is a perspective detail showing the manner of detachably uniting the said braces with the supporting-legs. Fig. 5 is a perspective detail of a section of the said braces at or near the middle of their length or point of union. Fig. 6 is a plan view of one of the legs, taken in cross-section with one of the braces connected therewith and broken away to show their interlocked engagement. Fig. 7 is a side elevation of one of the legs and illustrating the manner of connecting the brace thereto, the brace being shown in section.

Referring now particularly to Figs. 1 and 2 of the drawings, the tub-body is made of several pieces of sheet metal, constructed and rigidly united as follows: The cylindrical sides 1 are formed of one piece of transversely-corrugated sheet metal, whose ends are properly united by a water-tight seam and whose upper portion 2 is substantially vertical or cylindrical, while its lower and main portion 3 is made outwardly-flaring or conical, whereby the tub is slightly frusto-conical in contour. The lower edge of the portion 3 has a plain vertical flange 4, shouldered at its upper edge and upwardly turned at its lower edge.

The circular bottom 5 is radially corrugated and has its perimeter formed into a downturned annular flange 6 of substantially equal width with the flange 4 and has its lower edge upturned and pressed or rolled into a binding engagement with the lower edge of the flange 4, Fig. 1, forming a flattened bead 4', whereby the bottom 5 is rigidly and securely united to the sides of the tub. As the inner face of both the bottom and cylindrical sides are corrugated, they form an efficient rubbing-surface. The vertical or cylindrical portion 2 of the sides is surmounted and inclosed by a snugly-fitting plain band 7, having near its lower edge a plurality of annular strengthening and ornamental beads 8, and has its upper edge outwardly overturned with the adjacent edge of the top 9.

The circular top 9 has a central opening 10 of any desired contour surrounded by a re-

cessed or sunken flange 11, adapted to support a proper hinged top 12, whose upper face is thus flush with the upper face of the tub-top 9, has a proper handle 13 and a vertical central opening 14 for the upright agitator-shaft of any suitable washing-machine mechanism, and is firmly secured in position by means of a proper latch 15 upon the top 9. This top 9 is provided upon its perimeter with a raised horizontal flange 15', whose outer edge is downwardly and inwardly turned and, with the inclosed adjacent end of the band 7, is coiled about the wire 16 into a strong and firm bead 17. The top 9 has a recess or receptacle 18 for the soap and to form a place for the attachment of the wringer having proper drainage or outlet perforations 19.

The receptacle 18 may be variously formed, though preferably constructed of two pieces of metal, one of which forms the inner side 29 and the bottom 30, and the other piece forms the curved outer face 31, united to each other and to the tub by proper seams.

My improved tub is provided at diametrically opposite points and preferably between the annular beads 8 with proper handles 32.

The supporting-legs 20, four in number, are formed of a single piece of sheet metal of proper strength, corrugated, as shown, and having upon their upper end a flattened lug 21, laterally perforated for a pair of short bolts 22, by which they are rigidly secured to the inner face of the flange 4.

The legs 20 have their lower end bent outwardly to form a proper foot 23 and at a point approximately midway of their ends have a pair of lateral lugs 24 upon their inner face, Figs. 4 and 6, adapted to form a locked engagement with the adjacent ends of braces 25, which have a strengthening longitudinal corrugation 26 upon their outer faces and have their opposite ends provided with a reduced end 27, adapted to snugly fit within the said lugs 24 and engage the same. These braces are firmly connected midway of their ends, Fig. 5, by a proper bolt 28.

In crating the tub for shipment the braces 25 are detached and separated by removing the bolt 28 and disengaging the ends thereof from the lugs 24, after which the legs are detached from the tub by removing the bolts 22. As the legs and the corrugations 25 thereof are slightly tapering, it is obvious that while the braces can readily be removed upwardly from their engagement with the lugs 24 they cannot be forced downward, whereby when in position they cannot drop out or otherwise become disengaged in use.

It is obvious that as the sides of my tub are given great rigidity by the upright corrugations, the exterior band 7, the metallic top, and metallic corrugated bottom no hoops are necessary.

Having thus described my invention, what I desire to secure by Letters Patent is— 65

1. A sheet-metal tub of the class described, comprising a body tapering upwardly from its bottom to a point adjacent to its top and terminating thereat in a portion of uniform diameter, a sheet-metal top covering said body and terminating at its edges in a peripheral bead encircling the upper edge of the body, a sheet-metal band fitted upon the upper portion of said body and surrounding the portion thereof of uniform diameter, said band having its upper edge formed into a bead and surrounded by the peripheral bead of the top to lock said band upon the body, and supporting-legs connected to said body. 70 75

2. A sheet-metal tub of the class described, comprising a body having corrugations formed therein, said body tapering upwardly from its bottom to a point adjacent to its top and terminating thereat in a portion of uniform diameter, a sheet-metal top covering said body and terminating at its edges in a peripheral bead encircling the upper edge of the body, a sheet-metal band fitted upon the upper portion of said body and surrounding the portion thereof of uniform diameter, said band having its upper edge formed into a bead and surrounded by the peripheral bead of the top to lock said band upon the body, and supporting-legs connected to said body. 80 85 90

3. In a device of the class specified, a plurality of sheet-metal legs detachably secured at their upper ends as described, and having upon their inner face a pair of lateral lugs, and a plurality of diagonal braces rigidly united at their central portion and adapted for an interlocking union at their ends with the said lugs of the supporting-legs, in such a manner that when in position they impart great strength and rigidity to the legs, and yet are conveniently disengaged when it is desired to reduce the device to a knockdown condition. 95 100 105

4. In a tub of the class described, the combination with the tub proper, of a plurality of longitudinally - corrugated legs connected thereto, each of said legs having upon its inner face a pair of oppositely-arranged locking-lugs, and a series of braces extending between said legs, each of said braces having a reduced head at each of its ends, said heads fitting within the corrugations of the legs and being engaged by the locking-lugs, whereby said braces are held in engagement with the legs. 110 115

5. In a tub of the class described, the combination with the tub proper, of a plurality of longitudinally - corrugated legs connected thereto, each of said legs having upon its inner face a pair of oppositely-arranged locking-lugs, a series of diagonally-arranged braces extending between said legs, each of said 120 125

braces having a reduced head at each of its
ends, said heads fitting within the corrugations
of the legs and being engaged by the locking-
lugs, whereby said braces are held in engage-
5 ment with the legs, and means for uniting
said braces at their points of intersection.

Signed by me at Fort Wayne, in the county

of Allen and State of Indiana, this 15th day
of July, A. D. 1903.

JOHN C. PETERS.

Witnesses:

AUGUSTA VIBERG,
LULU E. BULMAHN.