

(19) **DANMARK**

(10) **DK/EP 3619468 T3**



(12) **Oversættelse af
europæisk patentskrift**

Patent- og
Varemærkestyrelsen

-
- (51) Int.Cl.: **F 21 V 19/00 (2006.01)** **F 21 V 23/00 (2015.01)** **F 21 V 29/75 (2015.01)**
- (45) Oversættelsen bekendtgjort den: **2024-10-14**
- (80) Dato for Den Europæiske Patentmyndigheds bekendtgørelse om meddelelse af patentet: **2024-09-18**
- (86) Europæisk ansøgning nr.: **18793906.1**
- (86) Europæisk indleveringsdag: **2018-04-27**
- (87) Den europæiske ansøgnings publiceringsdag: **2020-03-11**
- (86) International ansøgning nr.: **US2018029852**
- (87) Internationalt publikationsnr.: **WO2018204190**
- (30) Prioritet: **2017-05-03 US 201762500945 P** **2017-06-29 US 201715636923**
2017-07-17 US 201715651941 **2017-08-16 US 201715678880**
2017-08-16 US 201715678885 **2017-08-16 US 201715678855**
- (84) Designerede stater: **AL AT BE BG CH CY CZ DE DK EE ES FI FR GB GR HR HU IE IS IT LI LT LU LV MC MK MT NL NO PL PT RO RS SE SI SK SM TR**
- (73) Patenthaver: **Fluence Bioengineering, 4129 Commercial Center Drive , Suite 450, Austin, TX 78744, USA**
- (72) Opfinder: **DUONG, Dung, 12009 Uplands Ridge Drive, Bee Cave, TX 78738, USA**
JOHNSON, Randall, 9409 Prince charles Drive, Austin, TX 78730, USA
KLASE, Nicholas, 150 Post Oak Lane, Driftwood, TX 78619, USA
- (74) Fuldmægtig i Danmark: **Zacco Denmark A/S, Arne Jacobsens Allé 15, 2300 København S, Danmark**
- (54) Benævnelse: **Systemer og fremgangsmåder til et kølelegeme**
- (56) Fremdragne publikationer:
EP-A1- 2 208 922
CN-Y- 201 166 344
JP-A- S6 123 349
KR-U- 20100 012 997
US-A1- 2007 091 568
US-A1- 2013 155 673
US-A1- 2014 049 964
US-A1- 2014 318 153
US-A1- 2015 280 038

DESCRIPTION

Description

BACKGROUND INFORMATION

Field of the Disclosure

[0001] The invention relates to a method for manufacturing a fin and to a heat sink. An extruded heat sink having rails and fins parallel to the longitudinal axis of the heat sink is known e.g. from document US2014049964 A1. More particularly, embodiments disclose a heat sink configured to dissipate heat caused by a light fixture, wherein the heat sink includes exposed fins that allow for additional air flow.

Background

[0002] Greenhouses are buildings or complexes in which plants are grown. For various reasons including price, it is typically ideal for greenhouses to operate with as much natural sunlight as possible. To supplement natural light from the sun, high powered lights are used within greenhouses when the sun or other natural light does not provide enough light for optimal plant growth.

[0003] However, the operation of the high powered lights is more costly than utilizing free sunlight. More so, conventional high powered lights are larger in size, which blocks the incoming free sunlight. Furthermore, the blocking of the incoming sunlight causes shading on the plants within the greenhouse, which negatively impacts the grower's productivity.

[0004] Although light emitting diodes (LEDs) are more efficient than traditional high powered lights, their manufacturing costs are higher. Additionally, the LEDs cause excessive shading based on requiring larger fixtures to dissipate heat. To circumvent the large fixtures required to dissipate the heat, some manufacturers have attempted to build smaller LED fixtures that use active cooling fans. However, in greenhouse environments, active cooling fans quickly clog with dirt, bugs, etc. This causes the LED fixtures with active cooling fans to quickly become inoperable.

[0005] Conventional LED fixtures that do not include active cooling fans use traditional linear heat sinks. However, traditional linear heat sinks include wings that extend in a direction

parallel with a central axis of the conventional LED fixtures. Heat generated through conventional LED fixtures may dissipate based on convection, conduction or radiation. However, due to LED fixtures being suspended, there is minimal heat dissipation via conduction. Radiation is a function of the fixture temperature and may be significant, and convection is the primary method to dissipate heat. In applications, air particles remove heat from the fixture through air movement. For longer heat sinks, air movement within the middle of the fixtures is minimal. This severely limits the amount of power conventional LED fixtures can consume because additional power consumption leads to more heat.

[0006] Accordingly, needs exist for more effective and efficient systems and methods for heat sinks with exposed fins allowing for additional air flow.

SUMMARY

[0007] The present invention is set out by the appended independent claims and dependent claims.

BRIEF DESCRIPTION OF THE DRAWINGS

[0008] Non-limiting and non-exhaustive embodiments of the present invention are described with reference to the following figures, wherein like reference numerals refer to like parts throughout the various views unless otherwise specified.

FIGURE 1 depicts a cross flow heat sink, according to an embodiment.

FIGURE 2 depicts a cross flow heat sink, according to an embodiment.

FIGURE 3 depicts method of manufacturing a cross flow heat sink, according to an embodiment.

FIGURE 4 depicts method of using a cross flow heat sink, according to an embodiment.

FIGURE 5 depicts an unassembled cross flow heat sink, according to an embodiment.

FIGURE 6 depicted air flow lines generated by a heat source below the heat sink, according to an embodiment.

FIGURE 7 illustrates a method for a heat sink with a rib, according to an embodiment.

DETAILED DESCRIPTION

[0009] Embodiments utilize a series of exposed fins that increase the surface area of the heat sink creating additional air flow. The fins are exposed on both sides of a central axis of the heat sink and an upper surface of the heat sink. This allows cooler air to be drawn internally towards the central axis of the heatsink, above the heat source, and flow upward and out of the heat sink. This process may cool the fins by passively moving cooler air into the body of the heat sink. Additionally, the spacing between the fins may be wide enough to allow for air to freely enter the heatsink via the sides of the fins and/or through exposed lower surfaces of the fins.

[0010] FIGURE 1 depicts a cross flow heat sink 100, according to an embodiment. Cross flow heat sink 100 may be configured to dissipate heat from a heat source, such as a light fixture, wherein the light fixture may be positioned under heat sink 100. In a conventional linear heat sink, the heat generated from the heat source flows around a solid heat sink. In cross flow heat sink 100, the generated heat may be configured to flow through fins 110, and into spaces between fins 110. This may more rapidly and efficiently dissipate the generated heat. Heat sink 100 may include fins 110 and rails 120.

[0011] Fins 110 are extrusions from a unitary block of metal, such as aluminum. The extrusions consist of fins extending from an upper surface 140 of the unitary block of metal towards or to base 130, wherein the extrusions are formed by inserting the unitary block of metal through a die that include fin portions. Remaining portions of the unitary block of metal may form fins 110 via the negative of the die. The extrusions to fins 110 extend from a first edge 112 to a second edge 114 of heat sink 100. As such, the extrusions form fins that extend across the central axis of heat sink 100. In embodiments, the extrusions may create fins extending from first edge 112 to second edge 114. The extrusions may cause a plurality of evenly spaced fins 110 from a first end 116 to a second end 118 of heat sink 100. For example, each extrusion may cause fins 110 to be 1/6th of inch spaced from each other. However, in other embodiments fins 110 may have different even spacing, such as 1/3rd spacing, 1/4th inch spacing, etc.

[0012] Fins 110 have planar edges 112, 114, 140. Accordingly, sides of fins 110 extend in a direction perpendicular to the central axis of heat sink 100, and the upper surface 140 of fins 110 extend in a direction that is perpendicular to planar edges 112, 114.

[0013] Base 130 is formed simultaneously with the fins 110 by inserting the unitary block of metal through the die.

[0014] Rails 120 are coupled to base 130 via coupling mechanisms, such as screws 122, fasteners, etc. In embodiments, rails 120 may be bonded to base 130 via welding, adhesives, coupling mechanism, and/or any other type of fastening scheme. Rails 120 extend from first end 116 to second end of heat sink 118. Rails 120 may be configured to add rigidity and support for fins 110. Rails 120 may include planar external sidewalls, and tapered internal sidewalls 124. The internal sidewalls 124 may extend outward from a position below base 130 to the planar external sidewalls.

[0015] FIGURE 2 depicts a cross flow heat sink 100, according to an embodiment. Elements depicted in FIGURE 2 may be described above. For the sake of brevity, an additional description of these elements is omitted.

[0016] As depicted in FIGURE 2, base 130 forms a lower surface of fins 110, wherein base 130 is simultaneously with fins 110 by inserting the unitary block of metal into the die. Therefore, a secondary operation is not be necessary to create a continuously planar base 130.

[0017] Furthermore, rails 120 may be affixed to base 130 via screws 122.

[0018] FIGURE 3 illustrates a method 300 for manufacturing a heat sink, according to an embodiment. The operations of method 300 presented below are intended to be illustrative. In some embodiments, method 300 may be accomplished with one or more additional operations not described, and/or without one or more of the operations discussed.

[0019] At operation 310, a block of metal is inserted into a die. The may be utilized to cut or shape the block of metal to form fins and a base. The negative of the die may form a cross flow heat sink.

[0020] At operation 320, a base and fins are simultaneously formed by operation 310, wherein the block of metal is extruded to create a plurality of fins and the base. The extrusions may extend from an upper surface of the block of metal towards a lower surface of the block of metal, which is formed by the base. Additionally, the extrusions may occur across the width of the heat sink, which may create at least three exposed edges and a hollow chamber between adjacent.

[0021] At operation 330, rails are coupled to the base via coupling mechanisms. The rails may have a first ends coupled to the outer sidewalls of the base, and second ends positioned underneath the base, wherein the second ends may not be directly coupled to the base. The rails may be utilized to couple multiple sections of extruded metal together to form a continuous heat sink.

[0022] FIGURE 4 illustrates a method 400 for utilizing a heat sink, according to an embodiment. The operations of method 400 presented below are intended to be illustrative. In some embodiments, method 400 may be accomplished with one or more additional operations not described, and/or without one or more of the operations discussed. Additionally, the order in which the operations of method 400 are illustrated in FIGURE 4 and described below is not intended to be limiting.

[0023] At operation 410, air below a heat sink may be heated by a light fixture positioned directly below the heat sink.

[0024] At operation 420, the heated air may travel upward and around rails of the heat sink.

[0025] At operation 430, the heated air may travel into the body of the heat sink towards a central axis of the heat sink via extrusions on both sides of the heat sink between fins.

[0026] At operation 440, the heated air may conduct upward from a position proximate to the central axis of the heat sink above the light source, and away from the heat sink via extrusions between fins on the upper surface of the heat sink. Accordingly, as hot air rises, cooler air may be drawn into the heatsink. This process may cool the fins.

[0027] FIGURE 5 depicts an unassembled cross flow heat sink 500, according to an embodiment. As depicted in FIGURE 5, cross flow heat sink 500 may be comprised of various sections 510 of fins, wherein sections 510 are coupled together along a longitudinal axis of heat sink 500 via rails 120. As such, the length of the heat sink may be based on the number of sections 510 of heat sink 500 that are positioned adjacent to each other.

[0028] As depicted in FIGURE 6 it is desired to increase the heat flow from the heat source through the fins. By increasing the surface area of the heat sink 700 via the fins, as hotter air 730 rises cooler air is draw into the heatsink 700. The cooler air may cool the fins.

[0029] As depicted by air flow lines 730 in FIGURE 6, heat generated by a heat source below the heat sink 700 may travel around an overhang and towards a central axis of the heat sink 700. The hotter air positioned proximate to the central axis may rise due to cooler air entering the hat sink via the fins. Due to the fins created by the extrusions, the hotter air may be able to travel laterally and vertically through the heat sink.

[0030] Furthermore, the heat sink may include a rib 710. Rib 710 may extend across the central axis of the heat sink. However, rib 710 may not extend across the entire height of the fins. Rib 710 may be formed by not extruding across the entire height of a unitary block of metal along the central axis of heat sink 700. Rib 710 may be formed by the un-extruded block of metal, wherein two fins are formed on both sides of rib 710 by fully extruding the entire height of unitary block of metal on both sides of rib 710.

[0031] Additionally, the upper surface 720 of the fins may be extruded to form contours, depressions, grooves, ridges, projections, etc. By having a non-planar upper surface 720, turbulences may be created. The turbulences may cause more efficient air flow through the fins and heat sink.

[0032] FIGURE 7 illustrates a method 800 for a heat sink with a rib, according to an embodiment. The operations of method 800 presented below are intended to be illustrative. In some embodiments, method 800 may be accomplished with one or more additional operations not described, and/or without one or more of the operations discussed. Additionally, the order in which the operations of method 800 are illustrated in FIGURE 7 and described below is not intended to be limiting.

[0033] At operation 810, air below the heat sink may be heated by a light fixture positioned directly below the heat sink.

[0034] At operation 820, the heated air may travel around angled protrusions on the base of the heat sink, wherein the ends of the angled protrusions is positioned between the rib and the ends of the fins.

[0035] At operation 830, the heated air may enter the heat sink via partially exposed lower surfaces of the fins, wherein the lower surface of the fins are partially exposed from the first end of the protrusions to outer edges of the fins.

[0036] At operation 840, the heated air may conduct upward from a position proximate to the central axis of the heat sink above the light source on both sides of the rib. As hot air rises, cooler air may be drawn into the heatsink. This process may cool the fins.

REFERENCES CITED IN THE DESCRIPTION

Cited references

This list of references cited by the applicant is for the reader's convenience only. It does not form part of the European patent document. Even though great care has been taken in compiling the references, errors or omissions cannot be excluded and the EPO disclaims all liability in this regard.

Patent documents cited in the description

- US2014049964A1 [0001]

P a t e n t k r a v

1. Fremgangsmåde til fremstilling af en kølelegeme med en central akse, omfattende:

5 dannelse af en flerhed af finner, der strækker sig på tværs af kølelegemets centrale akse fra en første ende (116) af kølelegemet til en anden ende (118) af kølelegemet ved at ekstrudere en enhedsblok af metal;

 samtidig dannelse af en base med flerheden af finner, der er placeret under flerheden af finner;

10 koblingsskinner til basen, der strækker sig fra den første ende (116) af kølelegemet til en anden ende (118) af kølelegemet.

 hvor finnerne har plane kanter;

 hvor siderne af finnerne strækker sig i en retning vinkelret på kølelegemets centrale akse.

15

2. Fremgangsmåde ifølge krav 1, yderligere omfattende:

 at skabe mindst tre frilagte overflader mellem en første finne af flerheden af finner og en anden finne af flerheden af finner.

20

3. Fremgangsmåde ifølge krav 1, hvor skinnerne er dannet af et andet materiale end enhedsblokken af metal.

4. Fremgangsmåde ifølge krav 3, hvor skinnerne er dannet af aluminium, og enhedsblokken af metal er en aluminiumsblok.

25

5. Fremgangsmåde ifølge krav 1, hvor ekstruderingerne er jævnt fordelt.

6. Fremgangsmåde ifølge krav 1, yderligere omfattende:

 kobling af de første ender af skinnerne til en ydre sidevæg af basen; og

30

 placering af skinnernes anden ende under basen.

7. Kølelegeme med en central akse omfattende:

5 en flerhed af finner, der strækker sig på tværs af kølelegemets centrale akse fra en første ende (116) af kølelegemet til en anden ende (118) af kølelegemet, hvor flerheden af finner er dannet ved at ekstrudere en enhedsblok af metal, hvor ekstruderingerne forårsager afstand mellem enhver af flerheden af finner; en base, der samtidigt er dannet med flerheden af finner og placeret under flerheden af finner;

10 skinner koblet til basen, der strækker sig fra den første ende (116) af kølelegemet til en anden ende (118) af kølelegemet; hvor finnerne har plane kanter; hvor siderne af finnerne strækker sig i en retning vinkelret på kølelegemets centrale akse.

15

8. Kølelegeme ifølge krav 7, hvor ekstruderingerne skaber mindst tre udsatte overflader mellem en første finne af flerheden af finner og en anden finne af flerheden af finner.

20 **9. Kølelegeme ifølge krav 7, hvor skinnerne er dannet af et andet materiale end enhedsblokken af metal.**

10. Kølelegeme ifølge krav 7, hvor skinnerne er dannet af aluminium, og enhedsblokken af metal er en aluminiumsblok.

25

11. Kølelegeme ifølge krav 7, hvor ekstruderingerne er jævnt fordelt.

12. Kølelegeme ifølge krav 7, hvor første ender af skinnerne er koblet til en ydre sidevæg af basen, og andre ender af skinnerne er placeret under basen.

13. Kølelegeme ifølge krav 7, hvor skinnerne indbefatter en vinklet sidevæg og en plan sidevæg.

DRAWINGS

Drawing

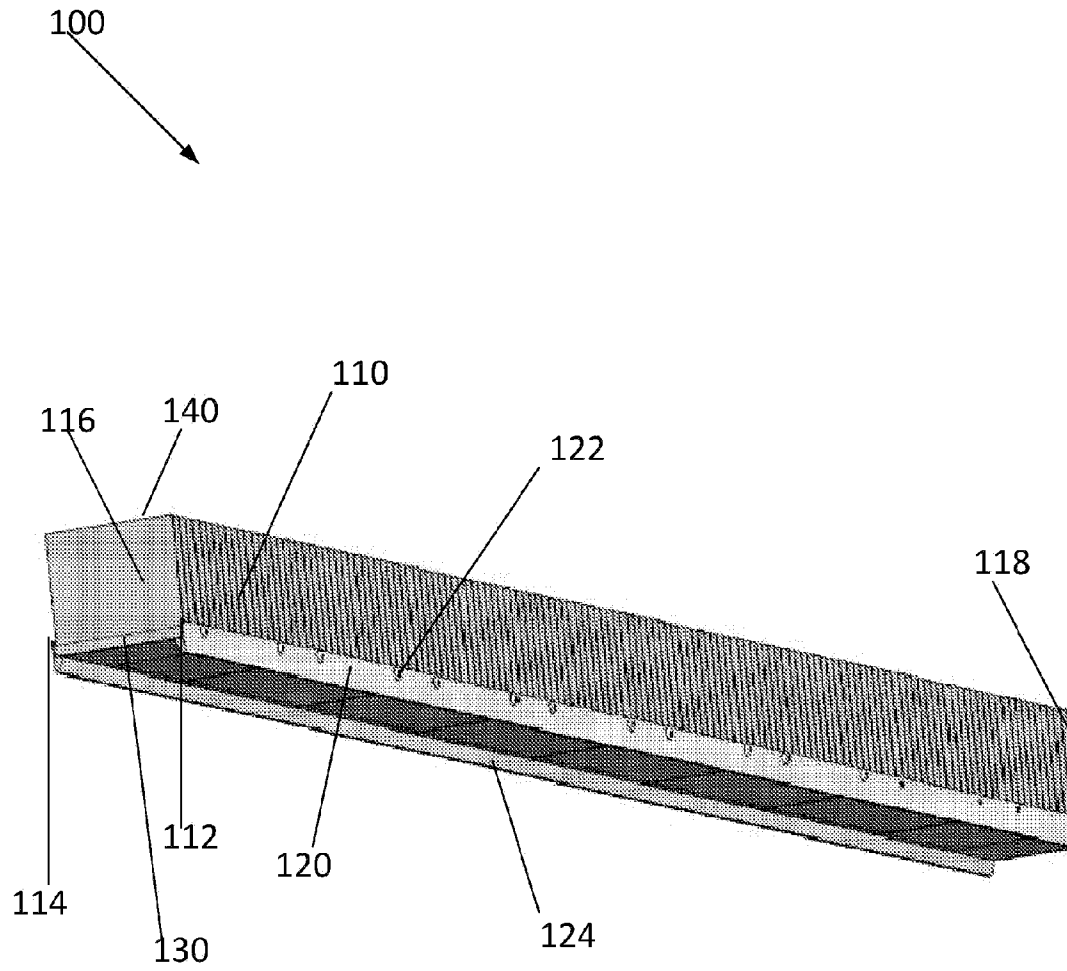

FIGURE 1

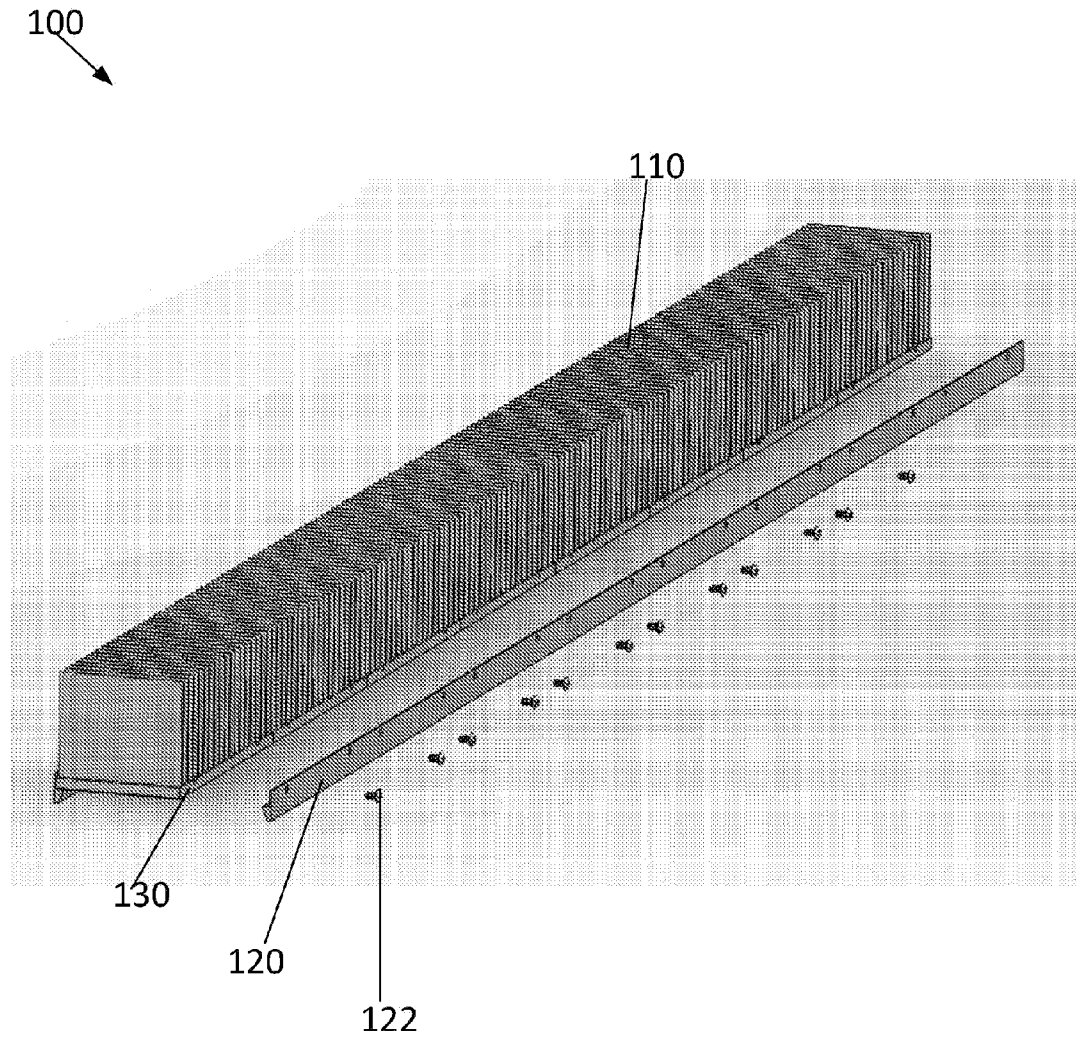

FIGURE 2

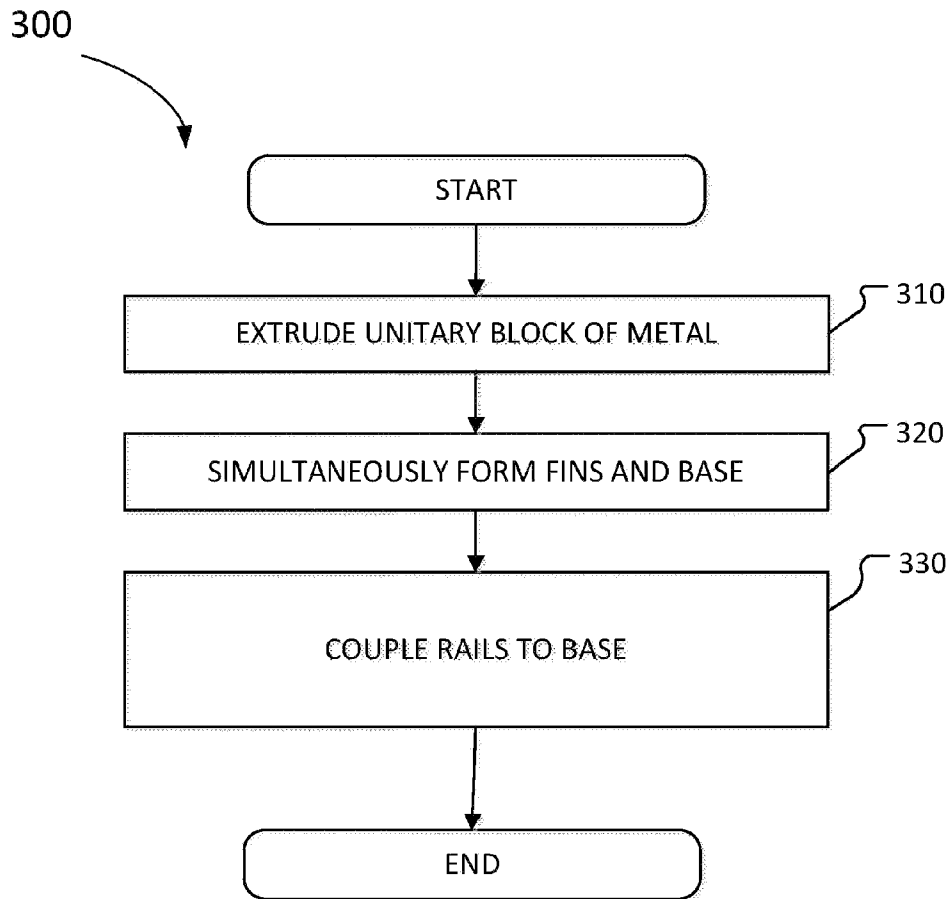

FIGURE 3

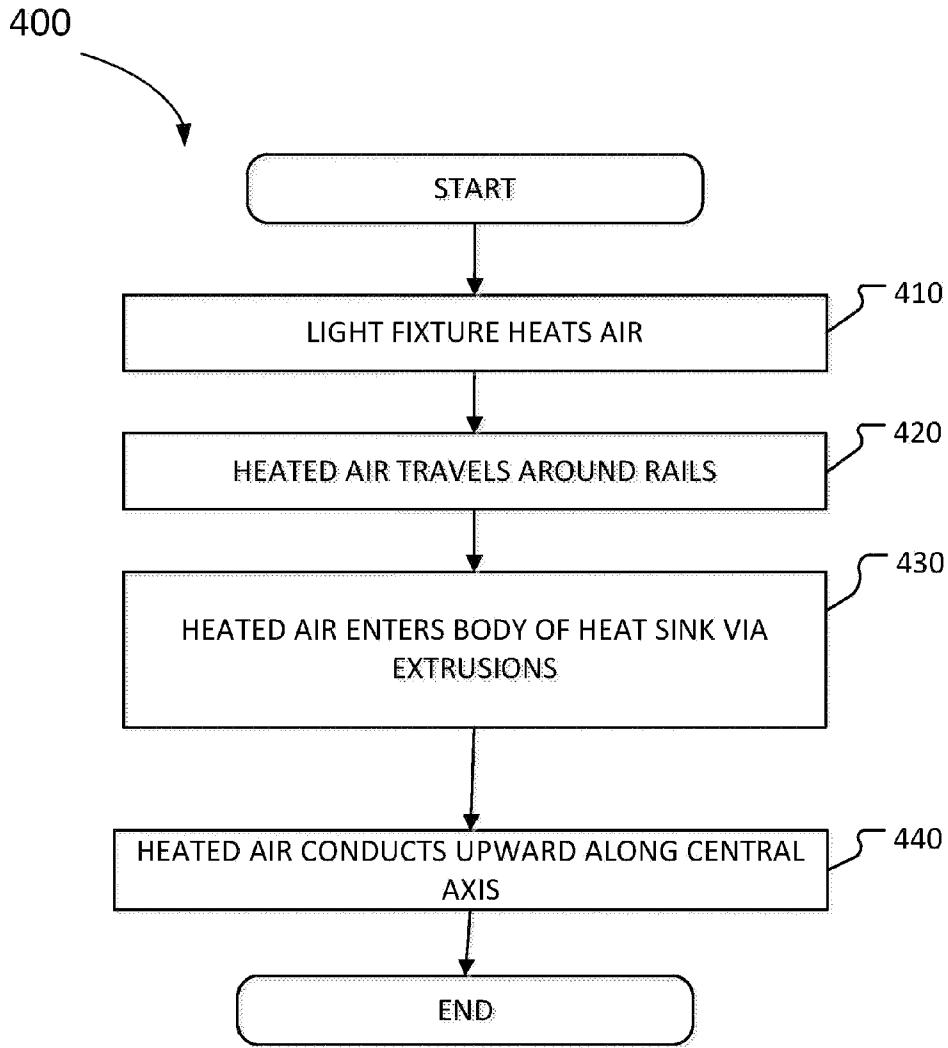

FIGURE 4

500

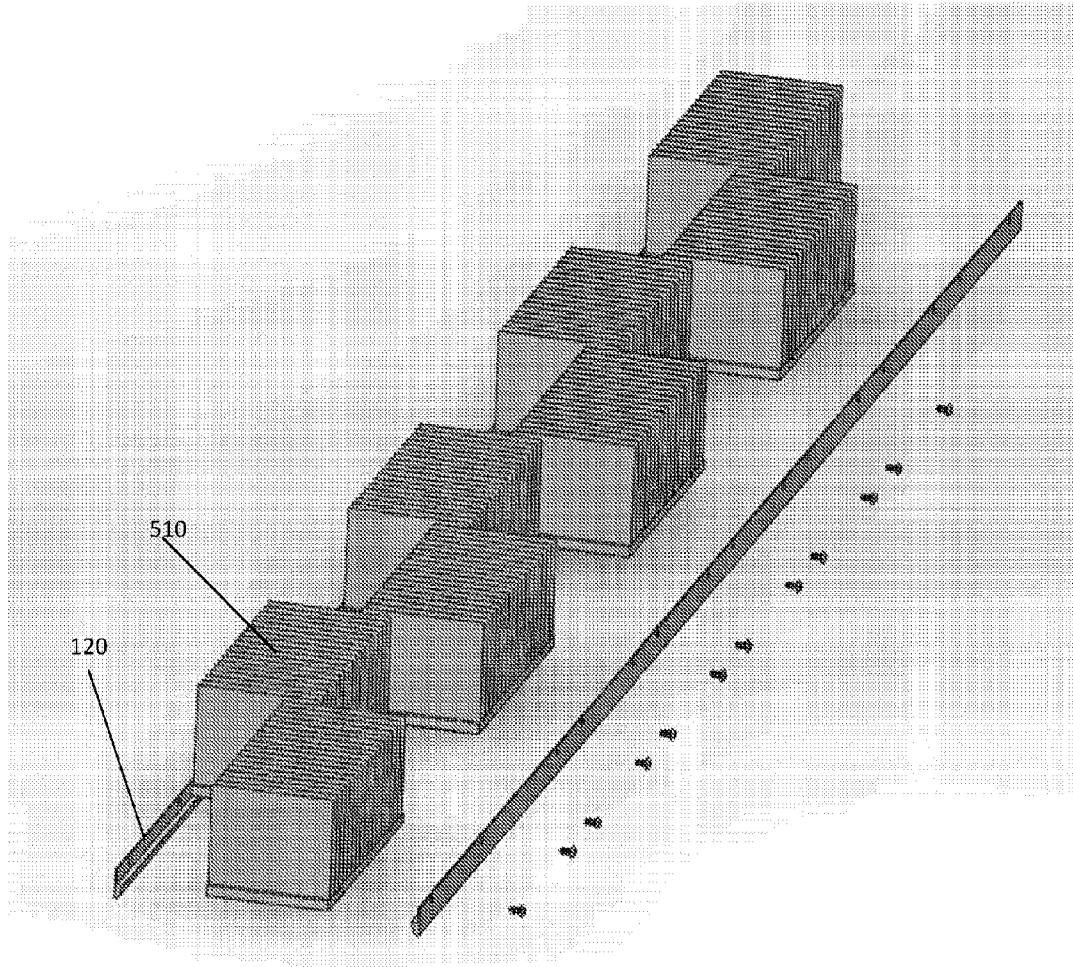

FIGURE 5

700

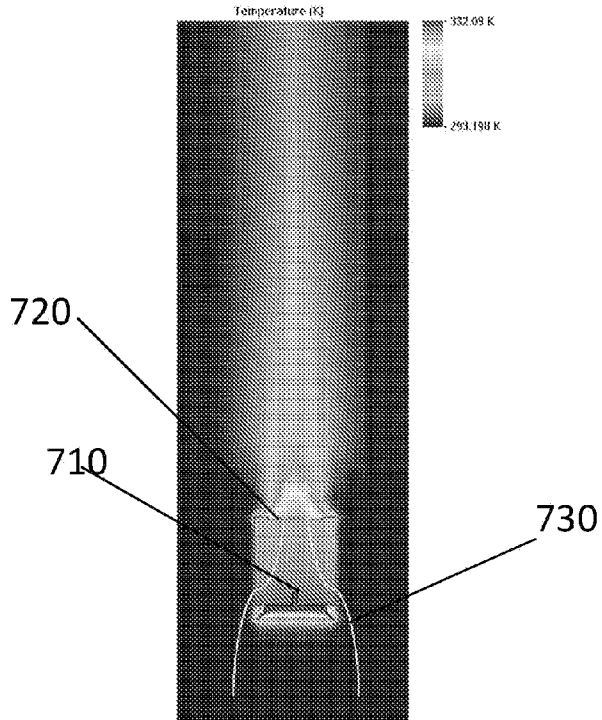

FIGURE 7

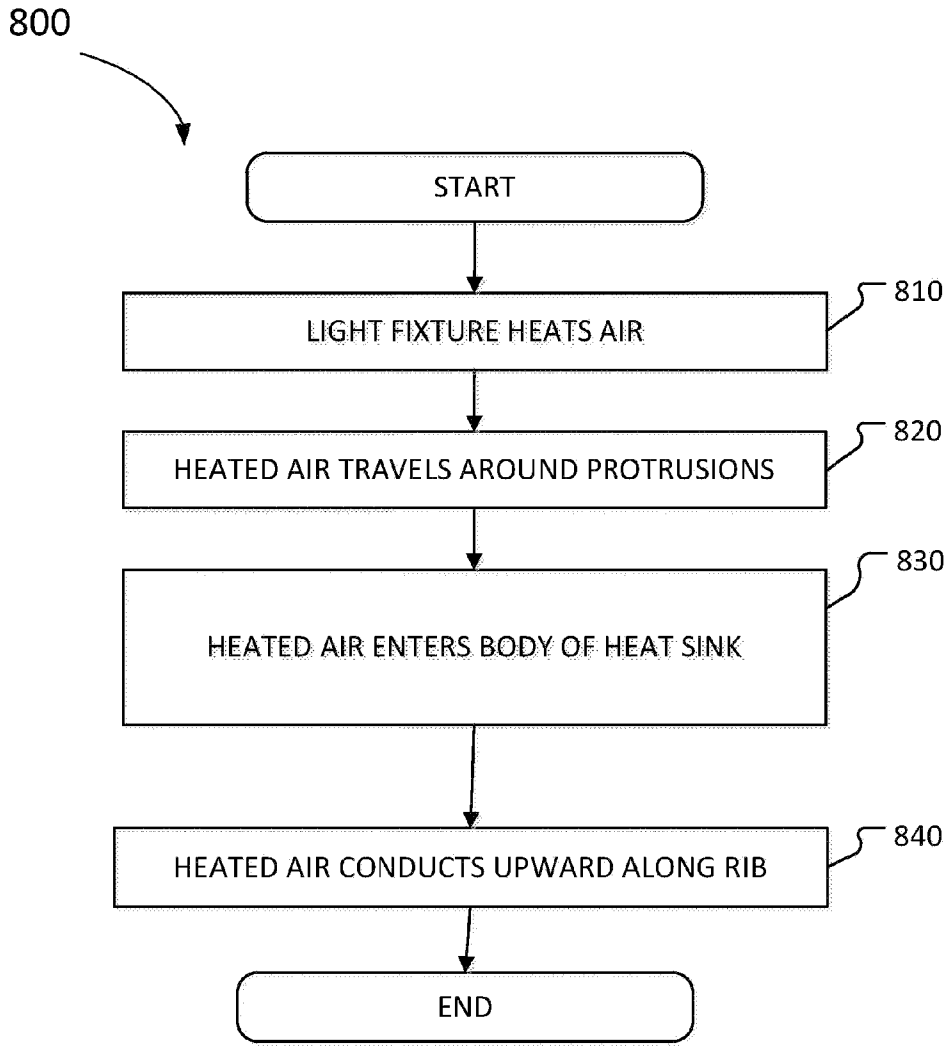

FIGURE 8