



(43) International Publication Date  
27 October 2016 (27.10.2016)

(51) International Patent Classification:  
H01Q 1/24 (2006.01)

(21) International Application Number:  
PCT/US2015/050583

(22) International Filing Date:  
17 September 2015 (17.09.2015)

(25) Filing Language: English

(26) Publication Language: English

(30) Priority Data:  
62/150,062 20 April 2015 (20.04.2015) US

(71) Applicant: THOMSON LICENSING [FR/FR]; 1-5 rue  
Jeanne d'Arc, 92130 Issy-les-Moulineaux (FR).

(72) Inventors: BOSE, William Hofmann; 3288 Valley  
Branch Road, Nashville, Indiana 47448 (US). HUNT,  
Mickey Jay; 6876 East Ann St., Camby, Indiana 46113  
(US).

(74) Agents: SHEDD, Robert D. et al.; Thomson Licensing  
LLC, 4 Research Way, 3rd Floor, Princeton, New Jersey  
08540 (US).

(81) Designated States (unless otherwise indicated, for every  
kind of national protection available): AE, AG, AL, AM,  
AO, AT, AU, AZ, BA, BB, BG, BH, BN, BR, BW, BY,  
BZ, CA, CH, CL, CN, CO, CR, CU, CZ, DE, DK, DM,  
DO, DZ, EC, EE, EG, ES, FI, GB, GD, GE, GH, GM, GT,  
HN, HR, HU, ID, IL, IN, IR, IS, JP, KE, KG, KN, KP, KR,  
KZ, LA, LC, LK, LR, LS, LU, LY, MA, MD, ME, MG,  
MK, MN, MW, MX, MY, MZ, NA, NG, NI, NO, NZ, OM,  
PA, PE, PG, PH, PL, PT, QA, RO, RS, RU, RW, SA, SC,  
SD, SE, SG, SK, SL, SM, ST, SV, SY, TH, TJ, TM, TN,  
TR, TT, TZ, UA, UG, US, UZ, VC, VN, ZA, ZM, ZW.

(84) Designated States (unless otherwise indicated, for every  
kind of regional protection available): ARIPO (BW, GH,  
GM, KE, LR, LS, MW, MZ, NA, RW, SD, SL, ST, SZ,  
TZ, UG, ZM, ZW), Eurasian (AM, AZ, BY, KG, KZ, RU,  
TJ, TM), European (AL, AT, BE, BG, CH, CY, CZ, DE,  
DK, EE, ES, FI, FR, GB, GR, HR, HU, IE, IS, IT, LT, LU,  
LV, MC, MK, MT, NL, NO, PL, PT, RO, RS, SE, SI, SK,  
SM, TR), OAPI (BF, BJ, CF, CG, CI, CM, GA, GN, GQ,  
GW, KM, ML, MR, NE, SN, TD, TG).

Published:

— with international search report (Art. 21(3))

(54) Title: STRAIN RELIEF ANTENNA WIRING CONNECTOR IN AN ELECTRONIC DEVICE

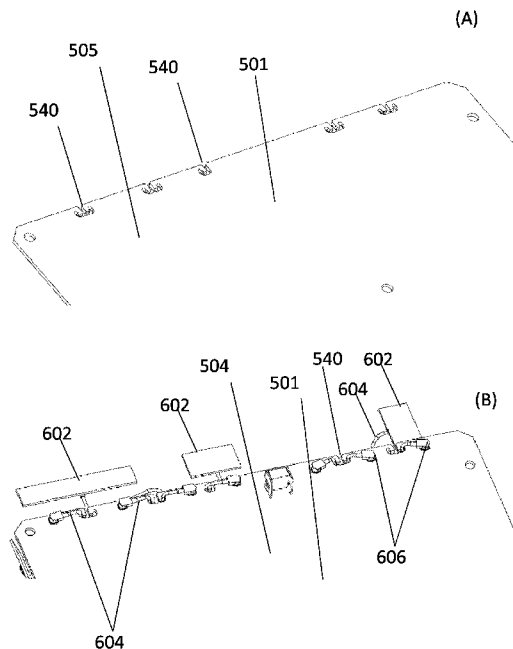

FIG. 41

(57) Abstract: A method is provided for manufacturing an electronic device that includes configuring one or more printed circuit boards with a plurality of antennas connected to at least one printed circuit board having wire securing slots. The electronic device can have a vertical orientation and an outer casing that includes a case bottom piece, a case top front piece and a case top back piece. The features can include providing staging slots in the case top back piece for holding the board at an angle with respect to the interior surface of the case top back piece to permit connections to the printed circuit board which can include connecting antenna wires to antenna connectors on the printed circuit board in which the antenna wires secured in the wire securing slots prior to connecting to the antenna connectors. The printed circuit board can be attached to only one side wall of one of the case front top piece or the case top back piece.

**STRAIN RELIEF ANTENNA WIRING CONNECTOR IN AN ELECTRONIC DEVICE**CROSS-REFERENCE TO RELATED APPLICATIONS

[0001] This application claims the benefit of U.S. Provisional Application Serial  
5 No. 62/150,062, filed April 20, 2015, which is incorporated by reference herein in its  
entirety.

FIELD

[0002] The present principles relate generally to electronics and, more  
10 particularly, to an electronic apparatus and antenna mounting arrangement within an  
electronic device.

BACKGROUND

[0003] Electronic devices such as set-top boxes are typically assembled  
15 apparatuses having a plurality of walls and other components. These other components  
can include printed circuit boards, heat sinks or heat spreader, wires, hard drives, smart  
card assemblies, and antennas. The plurality of walls and components make the  
assembly of these devices quite challenging in high volume manufacturing  
environments. As such, there is a need to insure that the components are staged,  
20 mounted, and installed in a manner that is fast and safe for the components. Further,  
there is a need to insure that the components are inspectable and designed in a manner  
that makes their installation as reversible as possible for rework in the factory or in the  
field.

[0004] As such, some devices such as the vertically oriented set top box disclosed in International Application No. PCT/US15/17791 filed on February 26, 2015 incorporate screwless attachment concepts to assemble the housings of the devices in such a way that the access to the devices in the field can be performed in a safe  
5 efficient manner by an authorized person without the need to undue screws. Such designs as in the above mentioned application make gaining access to the interior components of these devices more convenient and reduce excessive handling.

[0005] The casings of the vertically oriented set top boxes and gateway devices are relatively tall. The bases are generally narrow. With such a geometry, these designs  
10 present more challenges than the horizontally oriented set top boxes for screwless housing assembling. The reason is it is difficult to include a locking mechanism in these tall boxes that can extend from the top side to the bottom side of the boxes and yet still be able to house the plurality of necessary components which can include a plurality of antennas without interfering with the locking mechanism.

[0006] The need for a plurality of antennas in these vertically oriented set top  
15 boxes or gateway devices particularly presents a challenge. The problem is that in some designs up to 7 antennas are required, which means that additional wires must be used to connect the antennas to a circuit board and additional fixtures or antenna supports must be installed in the devices to support the antennas. Further, the antennas  
20 not only involve extra handling of the work product in the factory that place other components at risk and drive up manufacturing cost, but also these antennas have a propensity for electrostatic discharge in use. As such, designers must ensure that the antennas are adequately shielded in these devices which tend to be quite crowded.

Thus, the need exists for an antenna mounting system that is commensurate with the screwless attachment concepts and yet do not pose the risk of electrostatic discharge to and from the antennas.

[0007] These and other drawbacks and disadvantages presented by vertically oriented electronic devices are addressed by the present principles, which are directed to a vertical electronic apparatus and associated printed circuits. However, it can be understood by those skilled in the art that the principles can be taken advantage of in horizontally oriented devices as well.

10 SUMMARY

[0008] According to the present principles, a method is provided for manufacturing an electronic device that includes configuring one or more printed circuit boards with a plurality of antennas 602 connected to at least one printed circuit board having wire securing slots 540. The electronic device can have a vertical orientation and an outer casing that includes a case bottom piece, a case top front piece and a case top back piece. The features can include providing staging slots 230 in the case top back piece for holding the board 501 at an angle with respect to the interior surface of the case top back piece to permit connections to the printed circuit board which can include connecting antenna wires 604 to antenna connectors 606 on the printed circuit board in which the antenna wires 604 secured in the wire securing slots 540 prior to connecting to the antenna connectors. The printed circuit board can be attached to only one side wall of one of the case front top piece or the case top back piece.

[0009] According to the present principles, a method is provided for constructing a sub-assembly for incorporating into a plurality of different set top boxes and gateway devices that includes forming a plurality of slots along an edge of a printed circuit board, arranging a plurality of electrical connectors on a side of the printed circuit board adjacent to the edge, providing a plurality of antennas with respective lead wires, securing the respective lead wires in respective ones of the slots, and operatively connecting the lead wires to respective ones of the electrical connectors. The method can include supporting the antennas from a position above the printed circuit board and can include positioning the electrical connectors laterally with respect to the slots, in a direction parallel to the edge of the printed circuit board. The slots can be configured to be substantially T-shaped, substantially J-shaped, substantially L-shaped, or substantially check-mark (✓) shaped.

[0010] According to the present principles, an electronic device 200 such as a set top box or gateway device is provided that comprises a printed circuit board 501 having wire securing slots 540 along an edge of the printed circuit board and electrical connectors 606 on a side 504 of the printed circuit board adjacent to the edge and electronic components 602 having wires 604 extending therefrom in which the wires are each secured in one of the wire securing slots and connected to one of the electrical connectors. The wire securing slots can be substantially a J-shape, substantially a check design (✓) shape, substantially a T-shape, or substantially an L- shape. The electronic components can be antennas and the electrical connectors can each be positioned laterally with respect to the wire securing slots in a direction parallel to the edge of the printed circuit board. The electronic device can further comprise an antenna

bracket 601 that supports the antennas. The electronic device can further comprise a casing that is a vertically oriented structure in which the height of the casing is greater than horizontal widths of each of its sides and all horizontal depths of the casing. The antenna bracket can be positioned above the printed circuit board. The printed circuit  
5 board can be positioned vertically and the edge can be an upper edge of the printed circuit board. The antenna bracket can be a polygonal structure having at least two sides 603 that support the antennas. The printed circuit board can be secured to a rear wall 206 of the casing and can be parallel to the rear wall. The antenna bracket can also be secured to the rear wall (206) of the casing. The wires of the antennas can be routed  
10 to one of the sides of the antenna bracket and down to the wire securing slots. The rear wall can have at least one staging slot (230) in the at least one staging slot is configured to temporarily support the printed circuit board during assembly of the electronic device. The staging slot can be one elongated slot.

15 BRIEF DESCRIPTION OF THE DRAWINGS

[0011] The present principles can be better understood in accordance with the following exemplary figures, in which:

[0012] FIG. 1 is a perspective view of a vertically oriented electronic device 200 to which the current principles are applied;

20 [0013] FIG. 2 is a disassembled perspective view of the vertically oriented electronic device 200;

[0014] FIG. 3 is a perspective view of a retention clip 214;

[0015] FIG. 4 is a perspective view of the casing that shows how the pieces of the casing are assembled;

[0016] FIG. 5 is a perspective view of the casing that shows a case back retaining element;

[0017] FIG. 6 is a perspective view of the casing that shows a cross-section of an interlock;

5 [0018] FIG. 7 is a perspective view of the casing that shows an opening on the case front;

[0019] FIG. 8 is a perspective view of the retaining elements of the vertically oriented electronic device 200;

10 [0020] FIG. 9 is another perspective view of the retaining elements of the vertically oriented electronic device 200;

[0021] FIG. 10 is a disassembled perspective view of the vertically oriented electronic device 200;

[0022] FIG. 11 is a bottom perspective view of the vertically oriented electronic device 200 and the retention clips 214;

15 [0023] FIGs. 12-14 are various views of the retention clips 214;

[0024] FIG. 15 is a perspective view of the case bottom piece 213;

[0025] FIGs. 16 and 17 are perspective views showing how the bottom piece 213 engages the case top front piece and the case top back piece;

20 [0026] FIG. 18 is a bottom perspective view of the vertically oriented electronic device 200;

[0027] FIG. 19 is a view of the release fixture 300;

[0028] FIG. 20 is a flow diagram showing an exemplary method 2100 for assembling an electronic device having a case bottom piece, a case top front piece, and a case top back piece, commensurate with an embodiment of the present principles;

[0029] FIG. 21 is a flow diagram showing an exemplary method 2200 for  
5 disassembling an electronic device having a case bottom piece, a case top front piece, and a case top back piece, commensurate with an embodiment of the present principles;

[0030] FIGs. 22-25 show perspective views of circuit board assembly configuration 500 having wire securing slots 540 on one of the printed circuit boards to  
10 which the current principles are applied;

[0031] FIG. 26 is a perspective view of the circuit board assembly configuration 500 highlighting the connector 503 to which the current principles are applied;

[0032] FIGs. 27-28 are interior perspective views of the vertically oriented electronic device 200 showing the circuit board assembly configuration 500 to which the  
15 current principles are applied;

[0033] FIG. 29 is a flow diagram showing an exemplary method 4800 for assembling an electronic device having a case bottom piece, a case top front piece, and a case top back piece having printed circuit board staging slots 230, and a printed circuit board having wire securing slots 530, to which the current principles are applied;

20 [0034] FIG. 30 shows a rear perspective view of the set top box without the case, in which a plurality of antennas 602 are distributed over the circuit boards 501 and 502;

[0035] FIG. 31 shows various perspective interior views of the rear wall 206 with different components thereon to which the current principles are applied;



[0036] FIG. 32 shows a perspective view of a single unitary antenna bracket 601 that supports the plurality of antennas 602 within the electronic device according to the current principles;

[0037] FIG. 33 shows a rear perspective view of the antenna bracket 601 in  
5 relation to the circuit board 501 according to the current principles;

[0038] FIG. 34 shows various perspective views of the antenna bracket 601 and the pocket 605 therein which support the antennas 602 according to the current principles;

[0039] FIG. 35 shows a perspective view of the antenna bracket 601 and the  
10 antenna wires 604 routed to one bracket wall 603 according to the current principles;

[0040] FIG. 36 shows a perspective view of the antenna bracket 601 and the antenna wire 604 routed to one bracket wall 603 and toward the first printed circuit board 501 on the rear wall 206 of the electronic device according to the current principles;

15 [0041] FIG. 37 shows a rear perspective view of the antenna bracket 601 and the antenna wires 604 routed to one bracket wall 603 and down to the first printed circuit board 501 according to the current principles;

[0042] FIG. 38 shows two perspective views of the rear wall 206 having slots 230 thereon that facilitate easy installment of the antenna wires 604 to the connectors 606  
20 on the first printed circuit board 501;

[0043] FIG. 39 shows a perspective view of the rear wall 206 in which the antenna wires 604 are connected to the connectors 606 on the first printed circuit board 501 and in which the first printed circuit board is staged in the staging slots 230; and

[0044] FIG. 40 shows a perspective view of the rear wall 206 in which the first printed circuit board attached to the rear wall following the connecting of the antenna wires 604 and the removal of the first printed circuit board 501 from the staging slots 230; and

5 [0045] FIG. 41 shows two perspective views of the first printed circuit board 501 having the wire securing slots 540 thereon.

#### DESCRIPTION OF EMBODIMENTS

[0046] FIG. 1 shows a perspective view of a vertically oriented electronic device  
10 200 that houses an antenna bracket 601 and antennas 602. The device can include a top 210, a front wall 208, a rear wall 206, side walls 204, and a base 205.

[0047] FIG. 2 shows the three principal pieces of the vertically oriented electronic device 200. The three pieces are the case bottom piece 213, the case top front piece 211, and the case top back piece 212. The case top front piece 211 and the case top  
15 back piece 212 are upper parts of the device 200.

[0048] FIG. 3 is a perspective view of a retention clip 214 which can be optionally composed of metal and is utilized to engage and secure the case bottom piece 213 to the case top front piece 211 and/or the case top back piece 212. The retention clip 214 is positioned toward the bottom of the electronic device and is a key part of the locking  
20 mechanism applied on the electronic device. By having the retention clip 214 at the bottom, the antenna bracket 601 and the antennas 602 can be positioned at the other end of the electronic device; hence, the antenna bracket 601 (shown in FIG. 36 at the top end of the rear wall 206) and the antennas 602 do not interfere with locking and/or

unlocking of the electronic device. Additionally, the use of the retention clip 214 in concert with other features to be described permits easy access to the antenna bracket 601 and the antennas 602 when needed. The retention clip 214 can be part of a screwless locking mechanism positioned adjacent to the base 205 of the electronic device and can be remote from the antennas in the antenna bracket 601, especially when they are positioned adjacent to the top 210.

[0049] FIG. 4 shows how the case top front piece 211 is slid back onto the case top back piece 212 of the electronic device 200, and then up into retaining elements in order to lock the two pieces together such that internal electronic components can be housed therein when the assembly is finalized.

[0050] FIGs. 5-7 show the specific engagement mechanism 215, 216, 217 to which the current principles are applied. A protruding ledge 216 extends inwardly from the interior surface of one of the vertical walls of one of the pieces. The protruding ledge 216 includes a protrusion 215 that engages a protrusion receiving opening 217 on the case top front piece 211. The protrusion receiving openings 217 are generally horizontal ledges that have upstanding peripheral walls to make a slot that can receive the protrusions 215. The slots can be oversized in the dimension that is perpendicular to the interior surfaces of the vertical walls from which the horizontal ledge extends, or the slots can be oversized along its long lateral axis. The slot can be narrow along the dimension parallel to the vertical walls or along the horizontal ledge's short lateral axis to snugly fix the protrusions 215. The protruding ledge 216, the protrusions 215, and the protrusion receiving openings 217 form a screwless engagement structure 977. The arrangement of the protruding ledges 216 and the protrusions 215 can be spaced from

the interior top surface of the case top 210 to permit the antenna bracket 601 and the antennas 602 to be positioned at a lateral level between the interior top surface of the case top 210 and the protruding ledges 216 and the protrusions 215. This permits the antenna bracket 601 and the antennas 602 from interfering with the locking and/or

5 unlocking the pieces of the electronic device. FIGs. 8 and 9 show further perspective views of the retaining elements that are used to engage the case top front piece 211 with the case top back piece 212. FIG. 8 shows ribs 218 that are positioned above the protrusion receiving openings 217 and also extend inwardly from the interior surface of one of the vertical walls of the front piece 211. The ribs 218 would interfere with the

10 case rear retention element if an assembly start position is attempted that is too low. FIG. 9 shows that a chamfer 299 guides the case top 210 to an acceptable start location. Rib 218 prevents case front from starting in a position that is too low by preventing excessive case travel which can damage components.

[0051] FIG. 10 is a disassembled perspective view of the vertically oriented

15 electronic device 200 showing the interior of the case top front piece 211 and the case top back piece 212 of the electronic device 200 to which the current principles are applied. The retention protrusions 291, the retention openings 292, and the over travel prevention portions 293 are shown in FIG. 10.

[0052] FIG. 11 is a bottom perspective view of the vertically oriented electronic

20 device 200 in which the case bottom piece 213 is not attached.

[0053] FIGs. 12-14 are various views of the retention clip 214 to which the current principles are applicable. The retention clip 214 can be optionally composed of metal. The views show that the case top front piece 211 and the case top back piece 212 can

be attached to one another and can then be attached to the case bottom piece 213 using the retention clips 214. The retention clips 214 are retained by elements on the case top front piece 211 and the case top back piece 212. The clip 214 is generally V-shape and includes an anchor portion 220 which is one side of the V-shape. The anchor portion 220 has a rectangular planar shape and has an aperture 277 that fits into an anchor base 221 of the case top front piece 211 and the case top back piece 212. FIG. 14 shows how the aperture 277 of the anchor portion 220 engages a protrusion 221A in the anchor base 221 such that an inward pointing ledge at the top of the anchor portion 220 grasps a top portion of the anchor base 221 and a bottom inner wedge grasps the bottom portion of the anchor base 221 to secure the retention clip 214. This permits a locking portion 219 of the clip 214, which is the other side of the V-shape, to engage with elements of the case bottom piece 213 to close or assemble the electronic device 200. In particular, referring to Figs. 15-16, the top of the locking portion 219 can have a horizontal ledge that extends inwardly to contact a bottom surface of a clip engaging element 222. The locking portion 219 can further have an upward extension at the edge of the horizontal ledge to engage an edge of the bottom surface of the clip engaging element 222. As shown in 17, the outward spring force of the clip 214 causes the locking portion to move outward to engage the element 222. Although a V-shape is shown, a U-shape could be employed as well and both sides of the V or U-shape part can have different heights. The retention clip 214 and the engaging elements 222 can be part of a screwless locking mechanism positioned adjacent to the base 205 of the electronic device and can be remote from the antennas in the antenna bracket 601 which can be positioned adjacent to the top 210 of the electronic device.

[0054] FIG. 15 is a perspective view of the case bottom piece 213, which shows the base 205 and the clip engaging elements 222 that extend vertically upward from the bottom piece 213 to which the current principles are applied. The clip engaging elements 222 are designed to engage the locking portion 219 of the clips 214 on the case top front piece 211 and the case top back piece 212. A screwless clip and spring mechanism 288 is formed from the clips 214 and the clip engaging elements 222.

[0055] FIGs. 16 and 17 are perspective views showing how the case bottom piece 213 engages the case top front piece 211 and the case top back piece 212 to which the current principles are applied. Release finger 301 pushes the locking portion 219 inward to disengage the locking portion 219 as it enters an aperture 223.

[0056] FIG. 18 is a bottom perspective view of the vertically oriented electronic device 200 to which the current principles are applicable. The reason is that the apertures 223 for the unlocking are remote from the antenna bracket 601 and the antennas 602.

[0057] FIG. 19 is a view of a release fixture 300 to which the current principles are applied. FIGs. 16-19 show the release aperture 223 in base 205. A release finger 301 on a base of a release fixture 300 is permitted to enter the release aperture 223 to push the locking portion 219 inward toward the anchor portion 220, thereby removing the top portion of the locking portion 219 from the engaging element 222. This can be understood also with reference to FIG. 18 in which the release finger 301 (not shown in FIG. 18) will contact the outer edge of the locking portion 219 and move the locking portion 219 away from the engaging element 222.

[0058] FIG. 20 is a flow diagram showing an exemplary method 2100 for assembling an electronic device having a case bottom piece, a case top front piece, a case top back piece, an antenna bracket and antennas mounted therein. Here, at step 2105, the antenna bracket 601 is mounted onto an interior vertical wall of the case top front piece or case top back piece or mounted to a component that is mounted to the interior vertical wall of the case top front piece or case top back piece. At step 2110, the case top front piece 211 is attached to the case top back piece 212 to form a top structure 210 using a screwless engagement structure 977. At step 2120, the top structure 210 is attached to the case bottom piece 213 using a plurality of screwless clip and spring mechanisms 288. The case top back piece 212 includes printed circuit board staging slots 230 which are described in greater below.

[0059] The issue that arise with the antennas within the method above is that the antennas must be electronically connected to the antenna connectors on one or more printed circuits and it is difficult to make the plurality of connections. This difficulty can arise with other connections to the one or more printed circuits, because it is difficult to make certain connections when the circuit boards in already attached to casing walls and because it is difficult to hold the circuit boards still with one hand and make a plurality of connections with the other.

[0060] FIG. 21 is a flow diagram showing an exemplary method 2200 for disassembling an electronic device having a case bottom piece, a case top front piece, and a case top back piece having the antenna bracket 601 mounted therein. The method 2200 is applied to an assembled condition, wherein the case top front piece is attached to the case top back piece 212 to form a top structure 210 using a screwless

engagement structure 977, and the top structure is attached to the case bottom piece using a plurality of screwless clip and spring mechanisms 288. At step 2210, a release fixture 300 is moved vertically upward to cause the release fingers 301 to also move vertically upward toward a bottom of the electronic device to simultaneously disengage a locking portion 219 of each of the plurality of screwless clip and spring mechanisms 288, thereby allowing the case top front piece 211 and the case top back piece 212 to be removed upward from the case bottom piece 213. At step 2220, the case top front piece 211 slides down with respect to the case top back piece 212 to disengage the screwless engagement structure 977 and separate the case top front piece 211 from the case top back piece 212 such that electronic components included within the electronic device can be accessed.

[0061] The electronic device 200 can be a set-top box or the like and can be vertically oriented such that the height of the device is higher than the width of the front vertical surface and/or the rear vertical surface and/or the lateral depth. The lateral cross section can be a quadrilateral shape in which the front and back are parallel and the side surfaces are not parallel to one another. The device can be designed such that the release fixture and release fingers move vertically upward toward the bottom of the device to simultaneously disengage the plurality of the locking portions to allow the case top front piece 211 and the case top back piece 212 to be removed upward from the case bottom piece 213. The case top front piece 211 and the case top back piece 212 can then further be detached from one another by moving the case top in a motion opposite to that shown in FIG. 5 to attach the two pieces (case top front piece 211 and case top back piece 212). With the two pieces 211 and 212 attached, the assembly can be



reassembled or assembled by aligning the clip engaging elements 222 with the clip 214 when the release fixture is removed or not present.

[0062] As noted above, the electronic device 200 can be a quadrilateral generally in which the front and back are parallel and the side surfaces are not parallel to one another. However, the general quadrilateral shape can include some additional vertical connecting surfaces to make at least two additional minor surfaces (i.e. substantially smaller vertical surfaces) 280 between the rear wall 206 and side walls 204 (as shown in Fig. 4).

[0063] Further disclosed is a method of making a printed circuit board to printed circuit board electrical connection or configuration 500 when a second printed circuit board 502 is positioned at a right angle to the primary printed circuit board 501. This can include the second PCB being connected behind the primary PCB on the component side 504 and the second printed circuit board being positioned on a non-component or bottom side 505 of the primary PCB. The connection for the two PCBs is through connector 503.

[0064] FIGs. 22-25 show perspective views of circuit board assembly configuration 500 which can be employed in the vertically oriented electronic device 200 to which the current principles are applied. These views show wire securing slots 540 on the primary printed circuit board 501 along its upper edge. These slots 540 can be associated with connectors 606 which can be antenna connectors for antenna wires 604. The small plan view cross-section area of the configuration 500 from a bottom perspective makes the configuration 500 commensurate with the screwless casing design of the vertically oriented electronic device 200. The reason is the plan view

cross-section can effectively be a T-shape that can be positioned by design to avoid the screwless locking mechanism or vis-versa. Further, by having the antenna bracket 601 mounted in the finished product at heights in the device in which most of the antenna bracket 601 is above the top edge of the vertically oriented primary printed circuit board 501 makes the arrangement of the internal components further commensurate with the screwless casing design. With such an arrangement, the locking elements of the housing and the associated release fixture and release fingers for disassembly can be more freely positioned to avoid contacting or interfering with the printed circuit boards and/or other components. If one of the circuit boards were to be horizontally positioned, there would be less positions and greater constraints on the positioning of the locking elements of the housing and associated release fixture and release fingers. The circuit boards would need to be smaller and/or need to be positioned at higher locations with the device.

[0065] Since a component side 504 of PCB 501 can face a rear wall 206 of the housing of the electronic device, a problem is that access to the components on the component side 504 and access to a secondary PCB 502 may need to be made through an undesirable cable. Cables add cost and a point of potential failure. However, the connector 503 in FIG. 23 provides a way for the secondary PCB 502 to be directly attached to the primary PCB 501 in which the secondary PCB 502 is inserted into the connector 503. This arrangement reduces cost, improves quality and makes assembly easier, with fewer possibilities for assembly error.

[0066] Because the PCB arrangement shown in FIGS. 22 and 23 reduces the number of cables, it makes room for the use of the plurality antenna cables or wires 604

needed to transmit antenna electrical signal within the device. As observed in FIG. 24, if the antenna connectors 606 are positioned near the top edge of the first printed circuit board 501, it is possible to have the antenna connectors 606 on the component side 504. As such, the antenna wires 604 can be short and the overall number of  
5 cables/wires within the device itself can be kept to a minimum number.

[0067] Also, having the connector 503 being elongated to run along the major axis adds stability to the support of second PCB 502 and such a configuration of the connector 503 being positioned in a central portion of the primary board 501 allows the second board 502 to fit more conveniently in the casing in which case top front piece  
10 211 has a tapered shape in which the casing narrows to the front wall 208.

[0068] As shown in FIG. 25, in an embodiment, a portion of the second printed circuit board 502 includes an extension 591 of the second printed circuit board from a plane 592 that substantially abuts a surface of the second printed circuit board when the first printed circuit board 501 is connected to the second printed circuit board by the  
15 connector 503. Contacts 588 are arranged on the extension 591.

[0069] FIG. 26 is a cross sectional perspective view of a circuit board assembly configuration 500 highlighting the connector 503 and showing the contacts 506 that are on the interior cavity 508 of the connector 503 to which the current principles are applied. The connector 503 can be a rectangular structure having peripheral walls 507.  
20 The rectangular structure can have a leading edge 510 that can be a flange that faces the component side 504 of the PCB 501 and contacts the PCB 501 and a portion of the connector 503 that protrudes through aperture 509 in the first PCB 501. The connector 503 can extend back to the panel jack at the panel jack opening or can be connected to

a cable running to the panel jack. The panel jack can be on the rear wall 206 of the electronic device or can be a part of the rear wall. The rear wall 206 can be part of the case top back piece 212 in which some of the lower rectangular features on the piece 212 in FIG. 11 can represent a panel jack.

5 [0070] FIGs. 27-28 show interior perspective views of the vertically oriented electronic device 200 illustrating the circuit board assembly configuration 500 to which the current principles are applied. These views show that the primary PCB 501 can be screwed, bolted, or secured to the rear case or the case top back piece 212.

[0071] The view in FIG. 28 further illustrates that the secondary PCB 502 can  
10 have a heat spreader or heat sink 512 on one of its sides. The heat spreader or heat sink 512 can have a central contact portion 513 that thermally contacts the PCB 502 or heat generating components thereon. The spreader or sink 512 can have a planar peripheral portion that permits heat to be radiated or convected away from the PCB 502.

[0072] In an embodiment, the heat spreader or heat sink 512 can be generally  
15 parallel to the PCB 502 and both heat spreader or heat sink 512 and PCB 502 can be perpendicular to the PCB 501. The heat spreader or heat sink 512 can further provide structural support for the second PCB 502. Here, the heat spreader or heat sink 512 can have a base edge with a vertical ledge 588 that connects to the first PCB 501 or the case back 212 to support by the heat spreader 512 and in turn the heat spreader 512  
20 support the second PCB 502 through contact points 514 (which can be screws or bolts or the like). The contact points 514 can work in conjunction with connector 503 to support the PCB 502. The contact points can run along an edge of the PCB 502 opposite the edge of PCB 502 having the base edge (support edge). Other mechanical

connection features 799, such as screws or bolts, can secure the main board 501 to the electronic device 200.

[0073] FIG. 29 shows an exemplary method 4800 for assembling an electronic device having a case bottom piece, a case top front piece, and a case top back piece having printed circuit board (PCB) staging slots 230. At step 4801, one can provide an interior vertical wall of a case piece 206 having PCB staging slots 230 attached or formed thereon. These staging slots 230 will be discussed in more detail below and are shown in FIGs. 31, 33, 36, 38, and 39. At step 4802, the antenna bracket 601 with antennas 602 can be mounted onto the interior vertical wall or to a component thereon. It should be understood that alternatively the antennas 602 can be added to the bracket 601 after the mounting of the bracket. At step 4803, the PCB 501 is provided having wire securing slots 540 and the antenna wires 604 can then be inserted into the wire securing slots 540 in which the wire securing slots can be an L-shape to support one wire or a T-shape (i.e. made by an L-shape and its mirror image combined) to support two wires in which the T-shape is inverted compared to the L and one wire goes to the left side and one wire goes to the right side of the line segment of the T-shape that is parallel to the edge of the printed circuit board. The L-shape and T-shape cutouts are shown in Fig. 31D which is a magnified view of Fig. 31C in the wire securing slots region 541. At step 4804, an edge of the printed circuit board 501 is inserted into the staging slots 230 such that the printed circuit board (PCB) stands at an angle with respect to the interior vertical wall, and the antenna wires 604 can be connected to antenna connectors 606 on the printed circuit board. This is an intermediate process step and shown in FIG. 38. These steps 4802 and 4803 can also be used or can

alternatively be used to make other connections to the printed circuit board or printed circuit boards. At step 4804, the printed circuit board is removed from the staging slots and is attached to the interior vertical wall. At step 4805, the case piece having the printed circuit board is attached to other case pieces and the casing is closed to  
5 complete the assembly of the electronic device 200. This method 4800 can include one or multiple printed circuit boards in an electronic device 200. The mounting of the bracket can include the use of screws, bolts or the like. The method can include connecting the second printed circuit board 502 to the first printed circuit board 501 in a perpendicular configuration 500 by the connector 503 on the first printed circuit board  
10 501, by passing a portion of the second printed circuit board 502 through a second side of the first printed circuit board 501 to engage the connector 503 on the first side of the printed circuit board 501. The method can also include providing a structural support for a heat spreader or heat sink 512 having at least a portion thereof thermally contacting the second printed circuit board 502 or one or more heat generating components on the  
15 second printed circuit board 502, by connecting a vertical ledge of the heat spreader or heat sink 512 to the first printed circuit board 501 or to the case top back piece 212.

[0074] Although the staging slots have been beneficial, an embodiment of the current principles includes features as described in Fig. 29, but with no staging slots for the supporting the printed circuit board while the antenna wires are inserted in the wire  
20 securing slots. Instead the circuit board with the wire securing slots can be appropriately staged by something other than the staging slots such that the wires can be inserted in the wire securing slots.

[0075] FIG. 30 shows the feature of the set top box without the case in which a plurality of antennas 602 are distributed over the printed circuit boards 501 and 502 and outside the peripheries of one or both of the orthogonally arranged printed circuit boards 501 and 502. An embodiment can include only one board and less than 7 antennas.

5 Here, the first printed circuit board 501 with a board heat spreader and heat sink 520 (in which "board" refers to the heat sink or spreader being associated with the circuit board) is attached to one side of the first printed circuit board 501 that is opposite the side that connects to the second printed circuit board 502. The board heat spreader and heat sink 520 is between the first printed circuit board 501 and the rear wall 206 of the case  
10 top back piece 212 of the casing of the electronic device. The antennas 602 are connected to one of the circuit boards and, in this embodiment, are all attached to the first printed circuit board 501. The antennas 602 can be connected to the antenna connector 606 on the first printed circuit board 501 by way of the antenna wires 604. The antennas can be WIFI antennas and can be vertically oriented in the vertically  
15 oriented set top box as shown and positioned adjacent to the top 210 between the outer top peripheral edges of the printed circuit boards and the top 210 of the set top box. The antennas positioned along the rear wall 206 can be parallel to the rear wall 206 and laterally positioned to be between a vertical plane extending from the plane of the first printed circuit board 501 and the rear wall 206. The antennas 602 can be laminated  
20 antenna printed circuit boards.

[0076] FIG. 31A shows the rear wall 206 of the case top back piece 212 that is omitted in FIG. 30. FIG. 31B shows the board heat spreader and/or heat sink 520 positioned adjacent to the rear wall, and FIG. 31C shows the first printed circuit board

501 which is connected to the board heat spreader and/or heat sink 520 thereover.

These figures also show the staging slots 230 positioned on the interior wall of the rear wall 206.

[0077] Inspection of FIG. 30 shows that interior volume of vertically oriented  
5 electronic devices can be quite crowded with a complex arrangement of components  
that comprise circuit boards, the components on the circuit boards, and the components  
to which the circuit board components are physically or electronically connected. This  
crowdedness and complexity is further enhanced when a plurality of antennas is need,  
because the conventional arrangement of the antennas involves having its own  
10 independent support. This, in turn, adds to the number of interior components that must  
be individually staged, isolated from other components and installed. Further, in these  
vertically oriented electronic devices, it turns out that there are spatial constraints and  
inefficiencies with the individual supports. In other words, the need for rapid assembly in  
high volume factories makes it difficult to manufacture such devices in which the  
15 antennas are individually supported with their own supports.

[0078] In view of the above mentioned issues with individual supports and the  
need to shield and connect antennas, a single unitary antenna bracket 601 provided  
and shown in FIG. 32 for holding the plurality of antennas 602 and the staging slots 230  
provided and shown in FIG. 31 are helpful. The perspective view of FIG. 32 shows the  
20 antenna bracket 601 that holds multiple antennas and antenna wires 604. The antenna  
bracket includes multiple bracket walls or sides 603 to form a polygon structure and  
antenna pockets 605 supported on at least two bracket walls, wherein the antennas fit  
within the pockets and the pockets prevent electrostatic discharge to and/or from the



antennas. The antenna bracket 601 can have rounded corners and the sides 603, and the corners can follow or generally follow the interior contour of the vertical walls of the casing. FIG. 33 show a rear perspective view of the antenna bracket 601 in relation to the printed circuit board 501 and in relation to the staging slot 230. FIG. 36 further

5 shows the wire securing slots region 541 in which the plurality of the wire securing slots 540 can be distributed along an end of the printed circuit board 501.

[0079] FIG. 34 shows various perspective views of the antenna bracket 601 and how the antennas 602 slide into the pockets 605. In particular, the corner region 610 of the bracket 601 highlighted in FIG. 34A is enlarged in FIGs. 34B and 34C to show how  
10 the antenna 602 can be inserted into and supported by the pockets 605. The pockets 605 have a hollow structure with two broad walls parallel to the broad surfaces of the antenna and two openings. The pockets can further include two narrow opposing end walls that bridge the two broad walls. One opening can be at the top for the antenna to slide into and another opening at the bottom for the antenna wire 604 to extend through  
15 to connect preferably to one of the printed circuit boards.

[0080] FIG. 35 shows a perspective view of the antenna bracket 601 and how the antenna wires 604 can be routed to one bracket wall 603. This view along with the view in FIG. 30 shows that the antenna wires 604 can be routed from end of the antenna pockets 605 along the bracket walls 603 toward one of the bracket walls 603 and  
20 downward toward the antenna connector 606. Also, FIG. 35 and FIG. 34 show that the antenna bracket 601 can have mounting apertures 611 on at least one of its walls 603 to secure the bracket 601 to a wall of the housing of the electronic device or to a printed circuit board.

[0081] FIG. 36 shows a perspective view of the antenna bracket 601 and how the antenna wire 604 can be routed to one bracket wall 603 and down to the first printed circuit board 501 between the first printed circuit board 501 and the rear wall 206. The wires 604 can connect to connectors 606 at the edge of the first printed circuit board 501. This view shows that the bracket 601 and the printed circuit board can both be attached to the same wall 206 of the housing of the electronic device. FIG. 36 shows that the antenna bracket 601 can be positioned above the staging slots 230 and the printed circuit board 501 can be positioned below the staging slot 230 in the final configuration, after the antenna wires 604 are attached and the circuit board 501 is removed from the staging slots. FIG. 36 further shows the wire securing slots region 541 in which the plurality of the wire securing slots 540 can be distributed along an end of the printed circuit board 501.

[0082] FIG. 37 shows a rear perspective view of the antenna bracket 601 and how the antenna wire 604 can be routed to one bracket wall 603 and down to the first printed circuit board 501 and connect to antenna connector 606 at the edge of the first printed circuit board 501. This view shows that the bottom edge of the bracket wall 603 to which each of the wires 604 are routed can be separated from the top edge of the printed circuit board 501 to which the wires 604 are routed.

[0083] Although quite helpful, the implementation of the antenna bracket 601 shown in FIG. 37 has problems. It is difficult to attach the wires 604 when the first printed circuit board 501 is already attached to rear wall 206, because there are spatial constraints that do not allow for easy access to the side of the printed circuit board 501 that faces the rear wall 206. It is also difficult to attach the wires 604 to the connectors

when the bracket 601 is already attached to the wall 206 and the circuit board is not yet attached, because one needs to hold the circuit board 501 up with one hand and then try to connect each wire 604 individually. This is tedious and time consuming and requires great care, because the wires 604 are kept at short lengths to ensure they fit in

5 the housing, to ensure they do not interfere or entangle with other components, and to save on material costs. Attaching the wires to the circuit board before both the bracket and circuit board are connected to the rear wall 206 is also problematic, because some wires tend to disconnect due the difficulty in handling the bracket and board together when they are separate components that are intentionally not rigidly bound together.

10 The method 4800 in FIG. 29 addresses this problem with the introduction of the staging slots 230.

[0084] As such, the solution to ensure easy connections of the wires 604 to the connectors 606 on the first printed circuit board 501 can be better understood with reference to FIGs. 38A and 38B and the method described in FIG. 29. FIG. 38A is a

15 magnified view of section 570 of the intermediate assembly shown in FIG. 38B. In the view shown in Fig. 38A, the antenna wires 604 are not yet inserted into the wire securing slots 540. After the board heat sink is attached to the back wall 206 as shown in FIG. 31B, the circuit board 501 can be placed in staging slots 230. As such, the rear wall 206 of the casing of the electronic device includes staging slots 230 that are

20 adapted to support the circuit board in a vertical or upstanding position with respect to the rear wall 206, which is oriented horizontally to permit access and viewing of the underside of the printed circuit board. Once the antenna wires 604 are attached to the connectors 606, the circuit board 501 is removed from the staging slots 230 and

oriented parallel to the rear wall for the remaining steps and final assembly which is shown in FIG. 31C that omits the bracket. There can be two staging slots 230 which can have C-shapes, U-shaped or V-shaped profiles in which the open ends face one another. These profiles of the staging slots can extend perpendicularly inward from the rear wall 206 to have a sufficient depth to be able to support the printed circuit board which can be parallel to the bracket 601 at point in this temporary state.

5 [0085] FIG. 39 shows the antenna wires 604 attached to the connectors 606. At this point, the circuit board 501 can be removed from the staging slots 230 and oriented parallel to the rear wall 206 for the remaining steps and final assembly.

10 [0086] FIG. 40 shows the circuit board 501 after being removed from the staging slots 230 and oriented parallel to the rear wall for the remaining step and final assembly.

[0087] FIG. 41A shows a perspective view of the non-component/bottom side 505 of the first printed circuit board 501 having the wire securing slots 540 thereon.

15 [0088] FIG. 41B shows a perspective view of the component side 504 of printed circuit board 501 having the wire securing slots 540 thereon.

[0089] The implementation of the wire securing slots 540 shown in FIG. 41 has been proven to be quite helpful in the assembling of the vertically oriented electronic device 200 having the antenna brackets 601. The wire securing slots 540 removes or substantially reduces the strain on the antenna wires that invariably occurs and causes some coaxial connectors of the antenna wires 604 to unplug after the plugging step. This might occur in the various methods for assembling the device. For example, in the case with the following order of steps: placing the rear wall 206 of the casing on a bench; adding or installing the heat spreader or heat sink 512 to the rear wall; adding or

installing the antenna bracket 601 to the rear wall 206; placing the printed circuit board 501 on the bench; plugging the antenna wires 604 onto coaxial antenna connectors 606; adding the printed circuit board 501 with antennas 602 to the rear wall; routing the antenna wires 604 and antennas 602 to proper locations in the bracket.

5 [0090] With the implementation of the wire securing slots 540, the step of plugging the antenna wires can include sliding and/or securing the antenna wires 604 into the wire securing slots such that there is no strain between the antennas wire as it comes out from the wire securing slot 540 and extends to the antenna connector 606 on the printed circuit board.

10 [0091] In sum, FIG. 41 shows a solution to the antenna wire strain problem. The solution is the additional step or feature of adding wire securing slots 540 on the printed circuit board. As illustrated in the figures, there can be two types of wire securing slots 540: a single hook and a double hook cutout that curve from an edge of the printed circuit board 501. The hooks or slots of the wire securing slots 540 can have a J-shape  
15 or an L-shape cutout in the plane of the applicable printed circuit board. The advantage of the double hook is that one double hook takes up less room than 2 single hooks to accommodate two wires. If the L-shape is used and a single cutout is desired to accommodate two wires, a T-shape can be employed. The orientation of the T-shape would be inverted compared to the L-shape or the J-shape. The feature of the wire  
20 securing slots 540 can be incorporated with any of the assembly process. The key is that the J-space or L-shape permits the edge of the board 501 to hold the wire while the end of the wire 604 is connected. The J-space or L-shape grasps or holds the wire securely to permit the manipulation of the dangling or free portion of the antenna wire

604. The J-shape can include a flat bottom portion at the bottom of the J and a short curled portion (upward portion). The opening of the slot width must be large enough to accommodate the width of the wire; however, the wire securing slot 540 can taper down so the wire can be gripped tighter as the wire is advanced in the slot. The wire 602 can be secured in in the wire securing slots 540 by pushing the wire into the slot in a direction in the plane of the board and parallel to the linear part of the J-shape near the opening. The downward portion of the J-shape or L-shape can be perpendicular to the edge of the printed circuit board. The antenna wire 602 can remain in the wire securing slot 540 after the connection to the connector 606. The wire 602 can rest at the bottom of the J-shape or L-shape or can rest at the short curled up portion of the J-shape if the J-shape is employed. Although a J-shape and an L-shape have been disclosed here, other effective shapes are also possible that can include some longer entrance portion (downward portion), some bottom portion or cusp portion and some upward portion back toward the edge of the board. For example, different versions of a check design (✓) can be utilized, which can include one or both strokes (i.e. upward and downward) at an acute angle with the edge of the printed circuit board or one stroke perpendicular to the edge of the printed circuit board.

[0092] It should be noted that all examples and conditional language recited herein are intended for pedagogical purposes to aid the reader in understanding the present principles and the concepts contributed by the inventors to furthering the art, and are to be construed as being without limitation to such specifically recited examples and conditions.

[0093] Moreover, all statements herein reciting principles, aspects, and embodiments of the present principles, as well as specific examples thereof, are intended to encompass both structural and functional equivalents thereof. Additionally, it is intended that such equivalents include both currently known equivalents as well as  
5 equivalents developed in the future, i.e., any elements developed that perform the same function, regardless of structure.

[0094] Although the illustrative embodiments have been described herein with reference to the accompanying drawings, it is to be understood that the present principles are not limited to those precise embodiments, and that various changes and  
10 modifications may be effected therein by one of ordinary skill in the pertinent art without departing from the scope of the present principles. All such changes and modifications are intended to be included within the scope of the present principles. For example, although the embodiments generally refer to the components with a vertically oriented electronic device in which the vertical height of the device can be greater than the  
15 horizontal length of each of the side walls, the principles are intended to be useful and are intended to include horizontally oriented electronic device.

[0095] Additionally, although the sides of the vertically oriented electronic device as well as other components are characterized as being “vertical” or “vertically oriented,” it should be understood that these expression are intended to include surfaces which  
20 may have some curvature or some small deviations from being completely vertical (e.g. +/-10° from vertical can be considered vertical).

[0096] Also, it is intended that the expressions “rear” and “front,” the expressions “top” and “bottom,” and the expressions “vertical” and “horizontal,” as well as other

complementary terms are intended to be construed from the perspective of the observer of the figures; and as such, these expression can be interchanged depending upon the direction that the observer observes the device.



## CLAIMS:

1. An electronic device (200) comprising:

5 a printed circuit board (501) having wire securing slots (540) along an edge of the printed circuit board and electrical connectors (606) on a side (504) of the printed circuit board adjacent to the edge; and

electronic components (602) having wires (604) extending therefrom, the wires each being secured in one of the wire securing slots and connected to one of the electrical connectors.

10

2. The electronic device of claim 1, wherein the wire securing slots are substantially a J-shape or substantially a check design (✓) shape.

15 3. The electronic device of claim 1, wherein the wire securing slots are substantially a T-shape or substantially an L-shape.

4. The electronic device of claim 1, wherein the electronic components are antennas and the electrical connectors are each positioned laterally with respect to the wire securing slots in a direction parallel to the edge of the printed circuit board.

20

5. The electronic device of claim 4, further comprising an antenna bracket (601) supporting the antennas.

25 6. The electronic device of claim 1, wherein the electronic device is a set top box or gateway device, the wire securing slots are substantially a J-shape, substantially a check design (✓), substantially an L-shape, or substantially a T-shape, and the electronic components are antennas,

7. The electronic device of claim 1, wherein:

the electronic components are antennas;

5 the electronic device is a set top box or gateway device having a casing that is a vertically oriented structure in which the height of the casing is greater than horizontal widths of each of its sides and all horizontal depths of the casing; and

the electronic device comprises an antenna bracket (601) positioned above the printed circuit board and supporting the antennas.

10 8. The electronic device of claim 7, wherein:

the printed circuit board is positioned vertically and the edge is an upper edge of the printed circuit board; and

the antenna bracket (601) is a polygonal structure having at least two sides (603) in which some of the antennas are on at least two of the sides.

15

9. The electronic device of claim 8, wherein:

the printed circuit board secured to a rear wall (206) of the casing and parallel to the rear wall;

the antenna bracket are secured to a rear wall (206) of the casing; and

20 the wires of the antennas are routed to one of the sides of the antenna bracket and down to the wire securing slots.

10. The electronic device of claim 9, wherein the electrical connectors are each positioned laterally with respect to the wire securing slots in a direction parallel to the  
25 edge of the printed circuit board.

11. The electronic device of claim 1, wherein:

the electronic components are antennas;

the electronic device is a set top box or gateway device; and

5 the electronic device comprises an antenna bracket (601) positioned above the printed circuit board and supporting the antennas.

12. The electronic device of claim 11, wherein:

10 the printed circuit board is positioned vertically and the edge is an upper edge;  
and

the antenna bracket (601) is a polygonal structure having at least two sides (603) in which some of the antennas are on at least two of the sides.

13. The electronic device of claim 12, wherein:

15 the printed circuit board secured to a rear wall (206) of the electronic device and parallel to the rear wall;

the antenna bracket are secured to a rear wall (206) of the casing;

the wires of the antennas are routed to one of the sides of the antenna bracket and down to the wire securing slots; and

20 the wire securing slots are substantially a J-shape, substantially a check design (✓) shape, substantially an L-shape, or substantially a T-shape.

14. The electronic device of claim 13, wherein:

the electronic device has a casing that is a vertically oriented structure; and

25 the rear wall has at least one staging slot (230), the staging slots are configured to temporarily support the printed circuit board during assembly of the electronic device.

15. A method of constructing a set top box or gateway device (200) having a casing comprising:

providing a printed circuit board (501) having wire securing slots (540) along an edge of the printed circuit board and electrical connectors (606) on a first side (504) of the printed circuit board adjacent to the edge;

routing wires (604) of electronic components (602) into the wire securing slots (540) such that the wires enter through a second side (505) of the printed circuit board and exit the first side;

connecting the wires to the electrical connectors;

attaching the printed circuit board to a wall (206) of the casing; and

closing the casing.

16. The method of claim 15 further comprising forming wire securing slots by cutting or punching substantially a J-shape, a substantially check design (✓) shape, substantially an L-shape, or substantially a T-shape groves along the edge of the printed circuit board.

17. The method of claim 15 further comprising:

providing an antenna bracket (601) having a polygonal structure having at least two sides (603), at least two of the sides having pockets (605) for supporting at least one of the electronic components, wherein the electronic components are antennas;

routing the wires of the antennas into the pockets of the antenna bracket; and

mounting the antenna bracket to the wall of the casing.

18. The method of claim 17, wherein the casing is a vertically oriented structure and the printed circuit board is oriented vertically and parallel to the wall.

19. The method of claim 18, wherein the edge of the printed circuit board having the wire securing slots is an upper edge of the printed circuit board and the edge is at a lower lateral position than the antenna bracket upon the closing of the casing.

20. The method of claim 19 further comprising:

holding the printed circuit board in staging slots (230) on the wall of the casing during the connecting of the wires such that the printed circuit board is at an angle with respect to the wall; and

removing the printed circuit board from the staging slots on the wall for the mounting of the printed circuit board.

21. A method for constructing a sub-assembly for incorporating into a plurality of different set top boxes and gateway devices, comprising:

forming a plurality of slots along an edge of a printed circuit board;

arranging a plurality of electrical connectors on a side of said printed circuit board adjacent to said edge;

providing a plurality of antennas with respective lead wires;

securing said respective lead wires in respective ones of said slots; and,

operatively connecting said lead wires to respective ones of said electrical connectors.

22. The method of claim 21, further comprising: supporting said antennas from a position above said printed circuit board.

23. The method of claim 22, further comprising: positioning said electrical connectors laterally with respect to said slots, in a direction parallel to said edge of said printed circuit board.

24. The method of claim 21, further comprising:

configuring said slots to be substantially T-shaped, substantially J-shaped, substantially L-shaped, or substantially check-mark (✓) shaped.

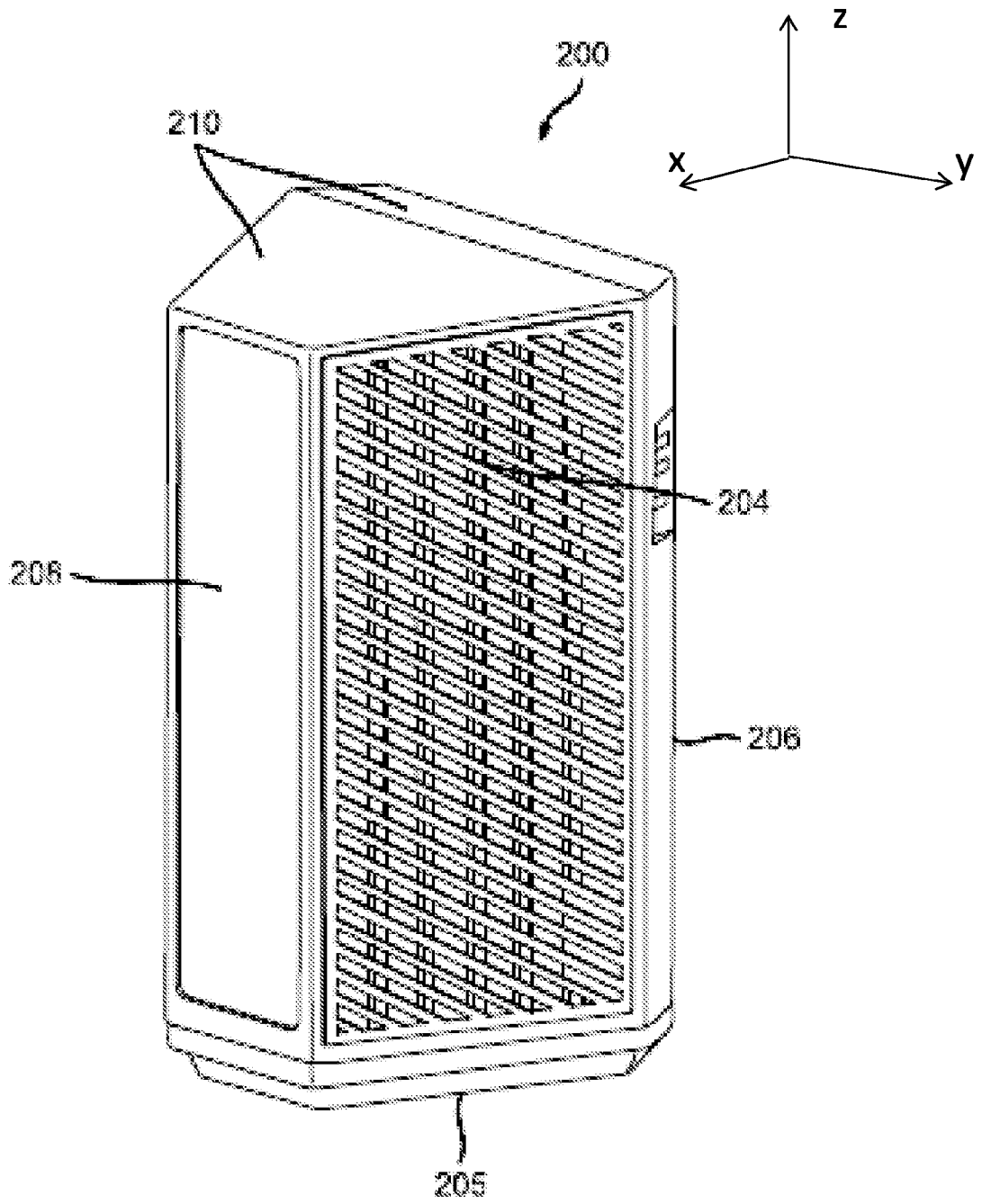

FIG. 1

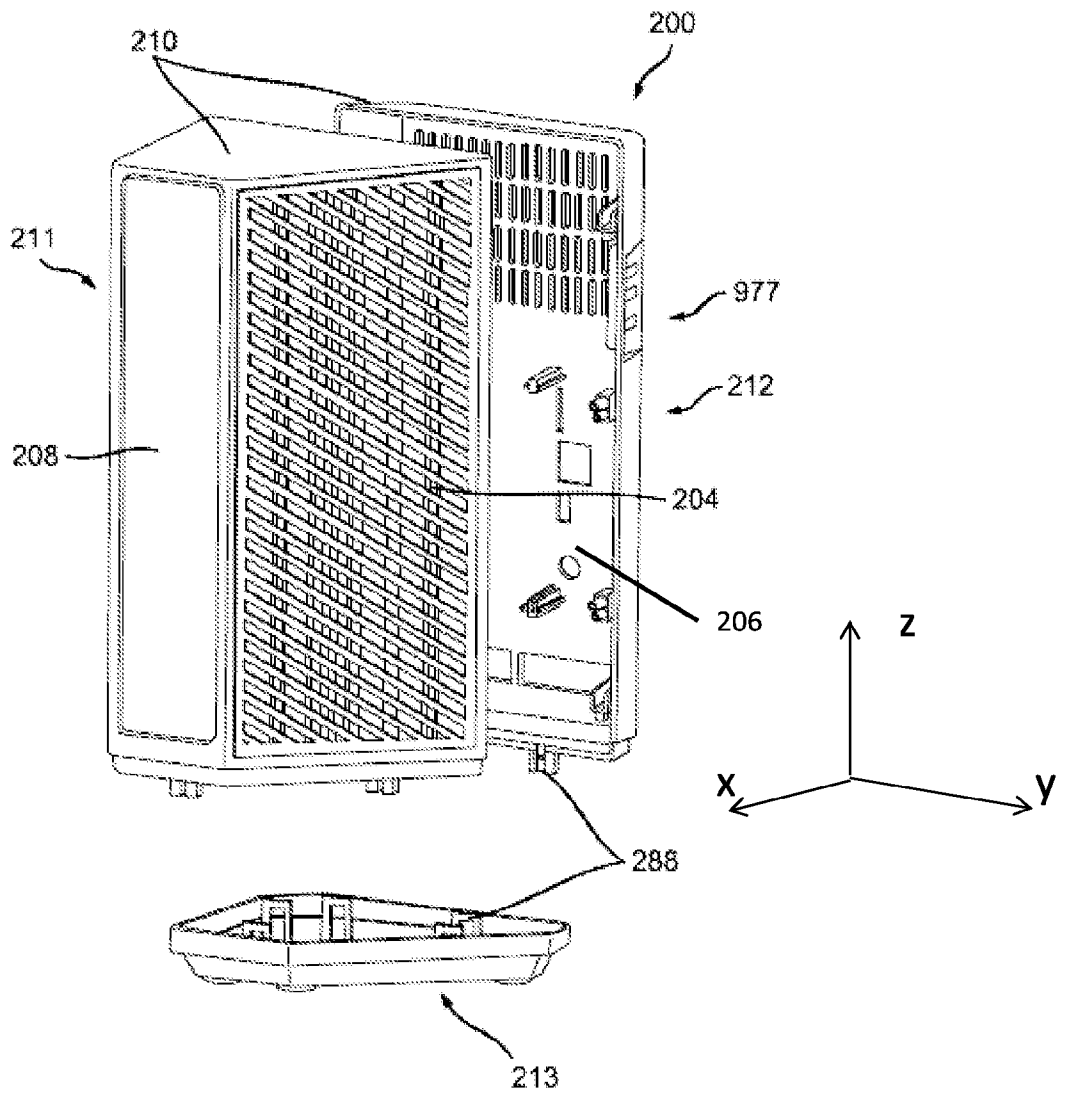

FIG. 2

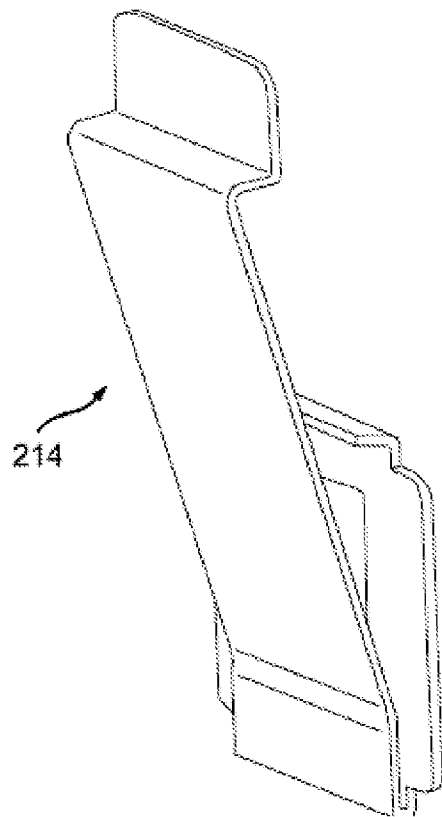

FIG. 3



4/33

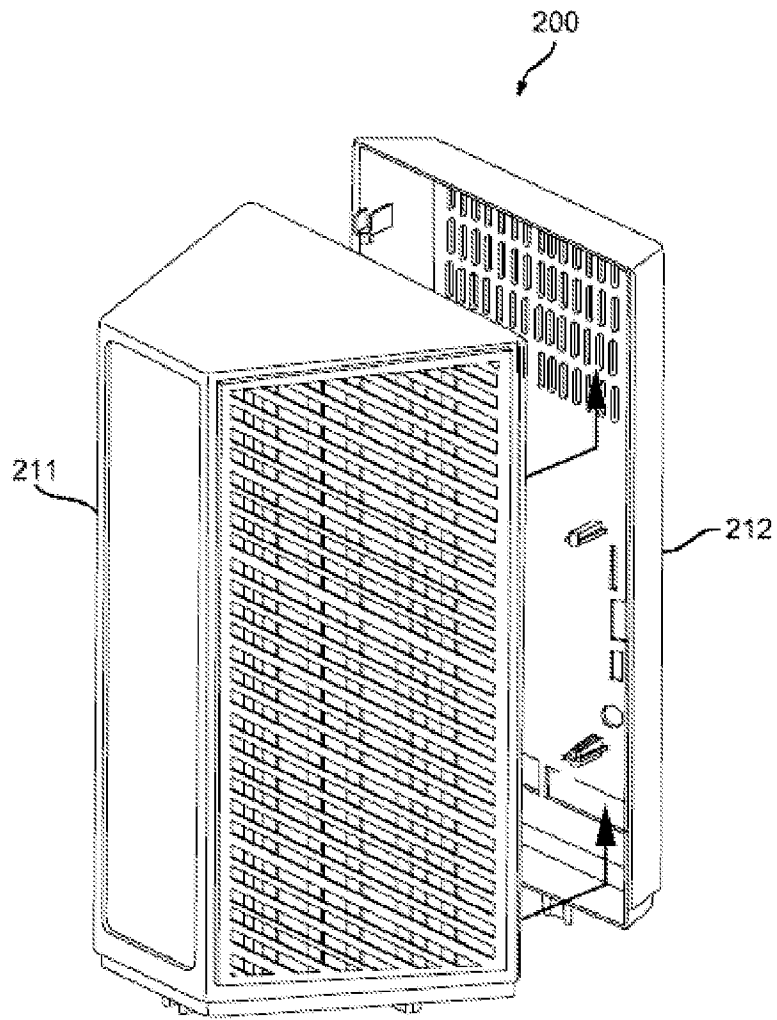

FIG. 4

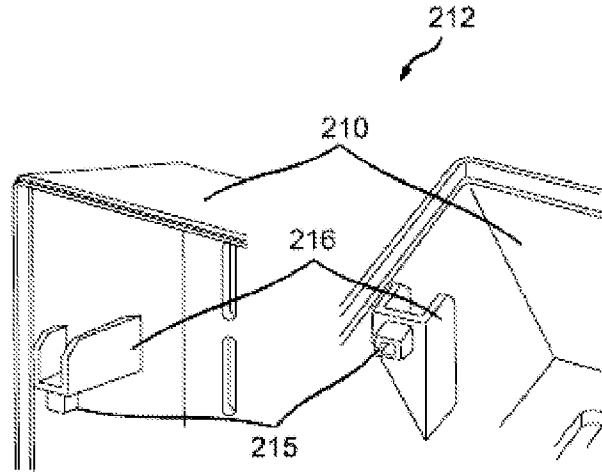

FIG. 5

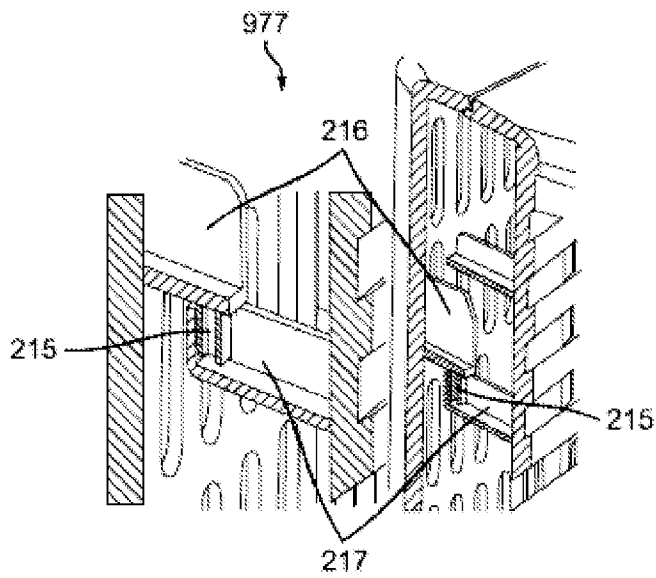

FIG. 6

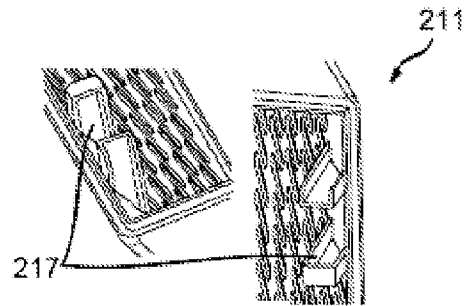

FIG. 7

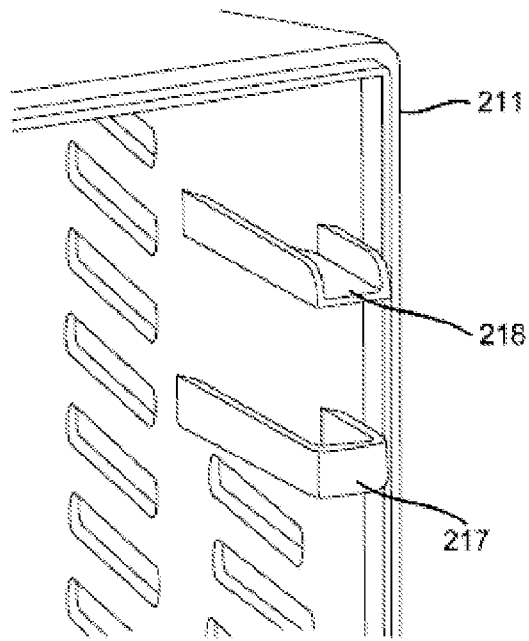

FIG. 8

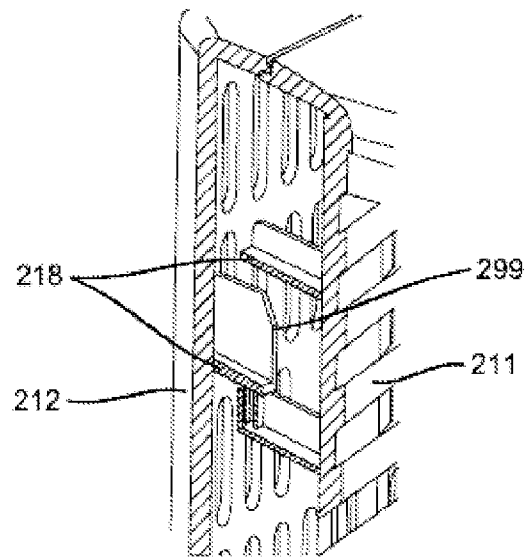

FIG. 9

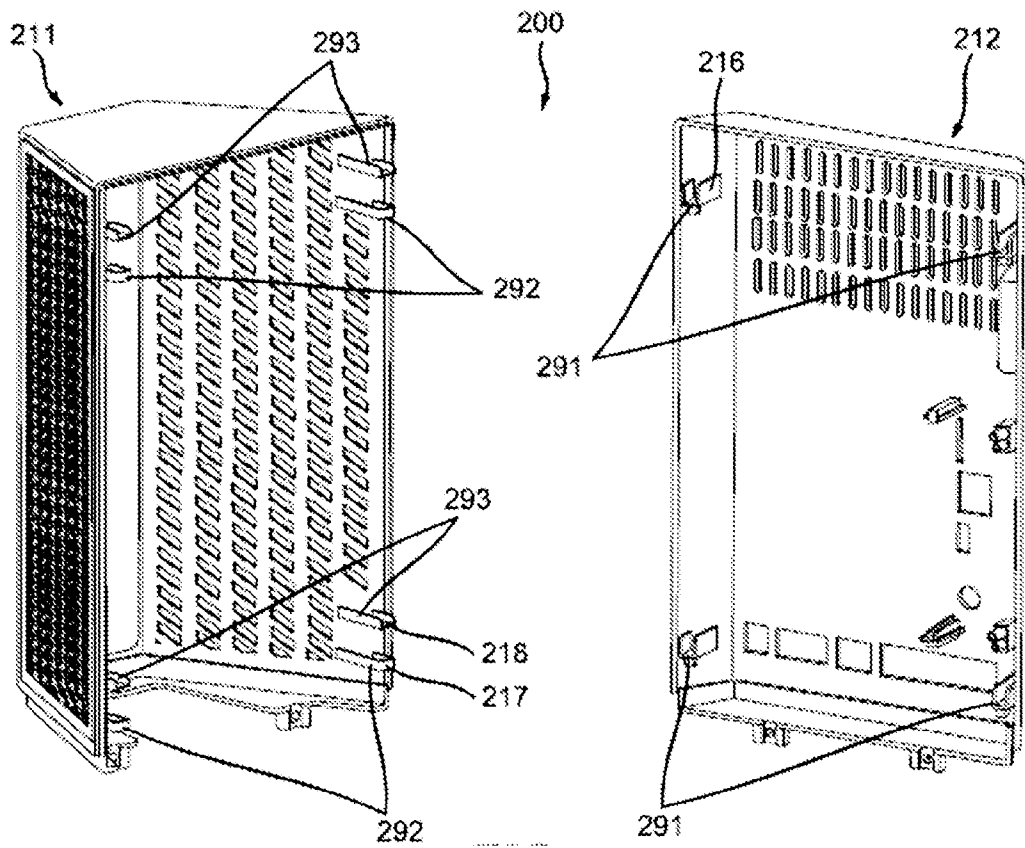

FIG. 10

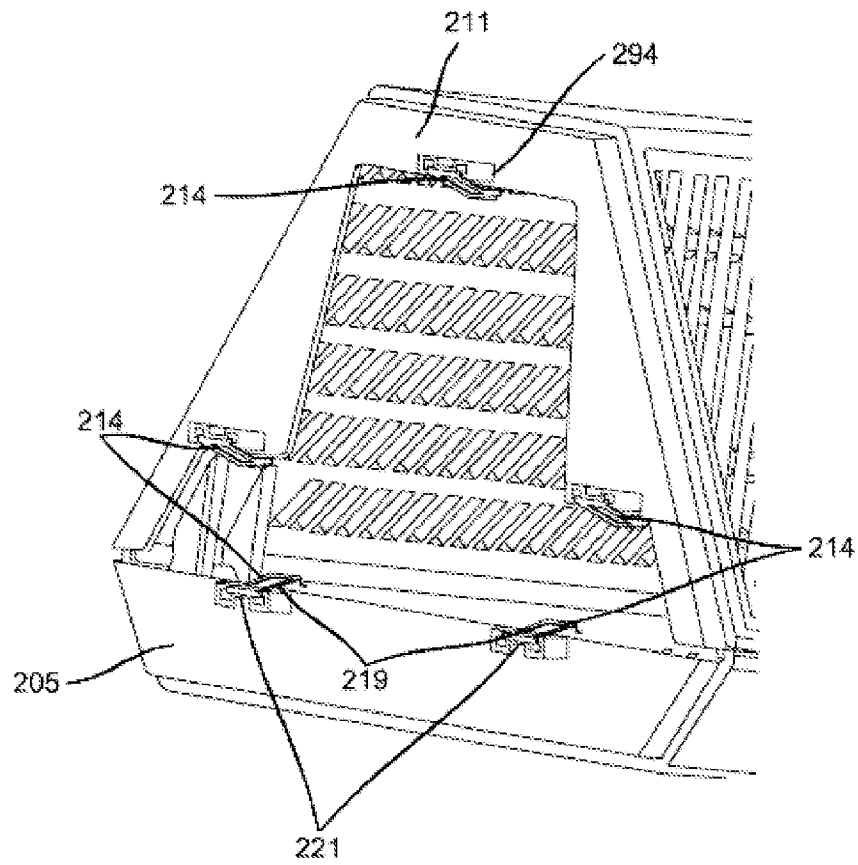
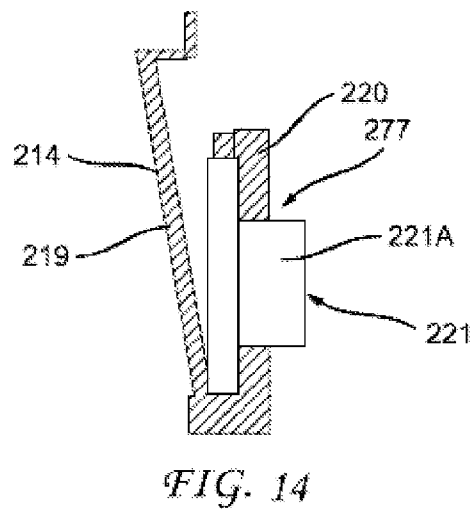
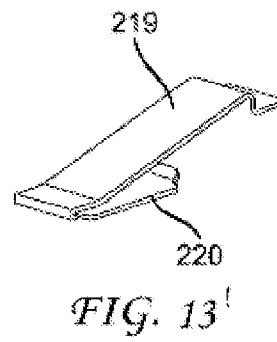
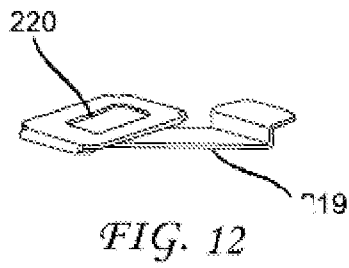

FIG. 11



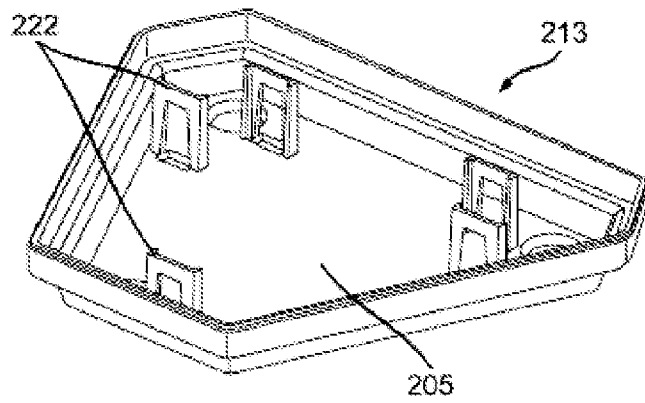

FIG. 15

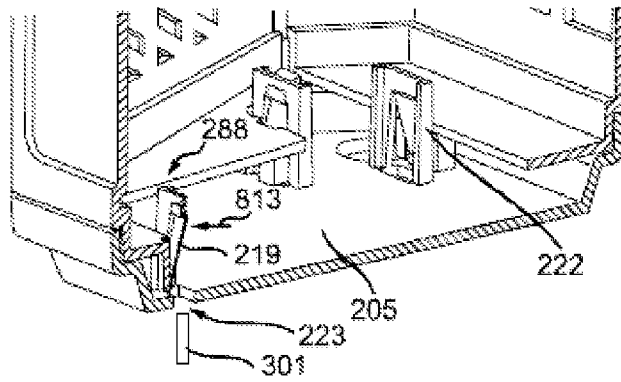

FIG. 16



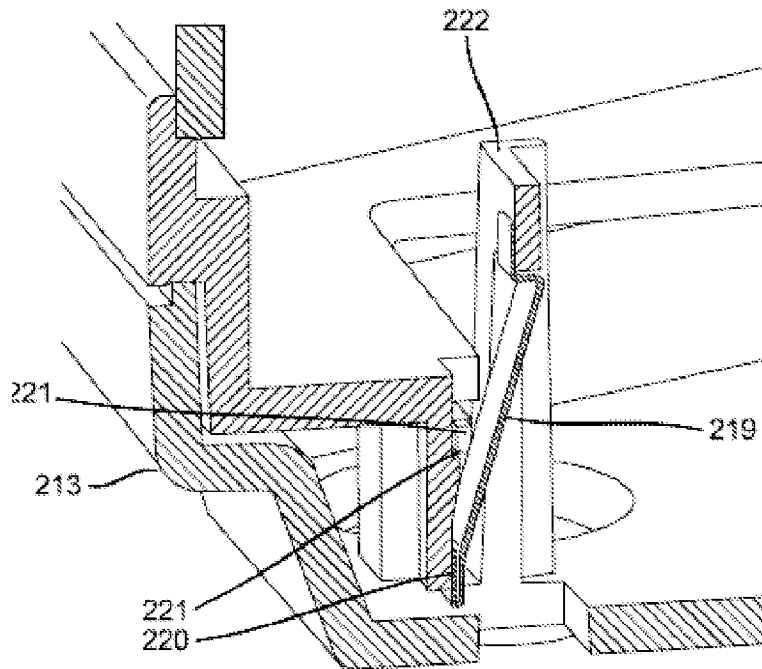

FIG. 17

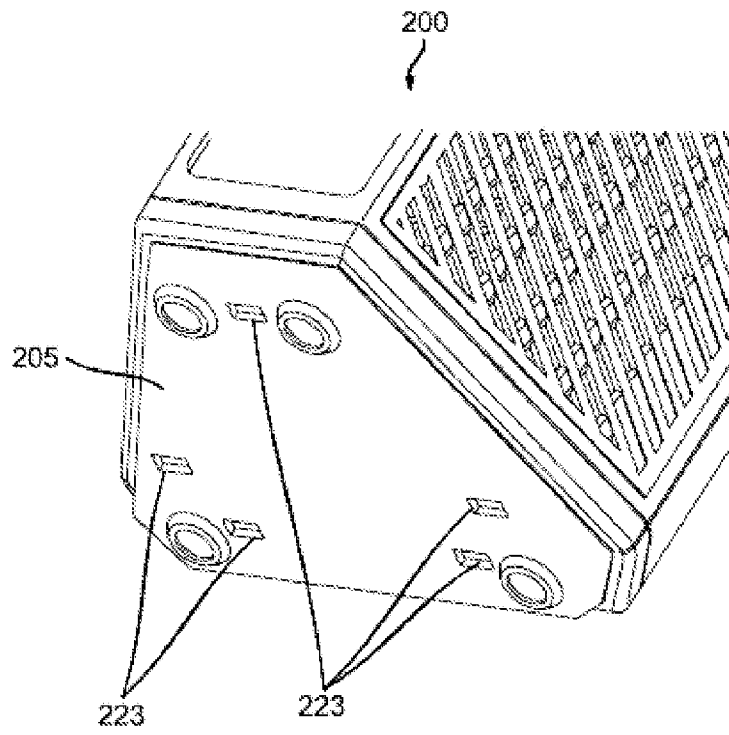

FIG. 18

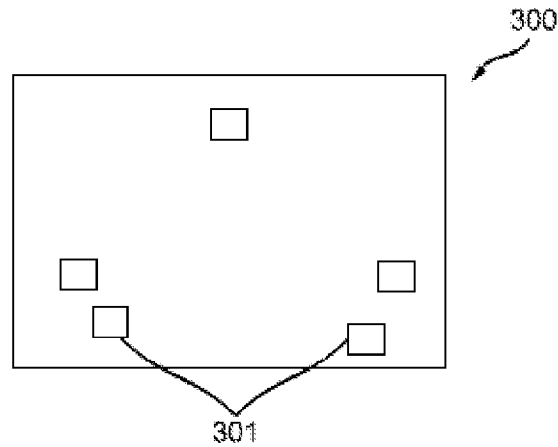

FIG. 19

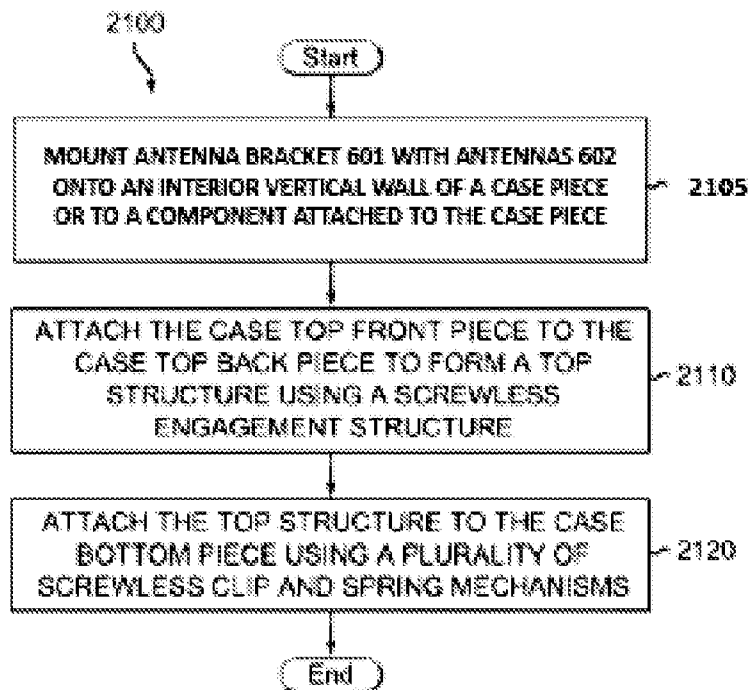

FIG. 20

15/33

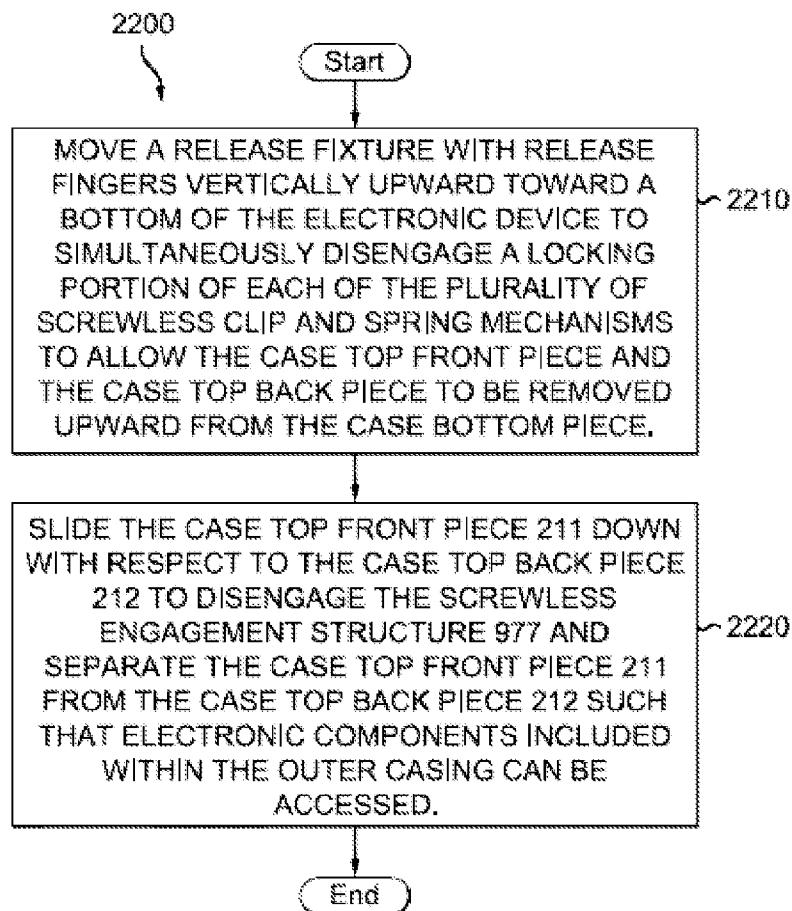

FIG. 21

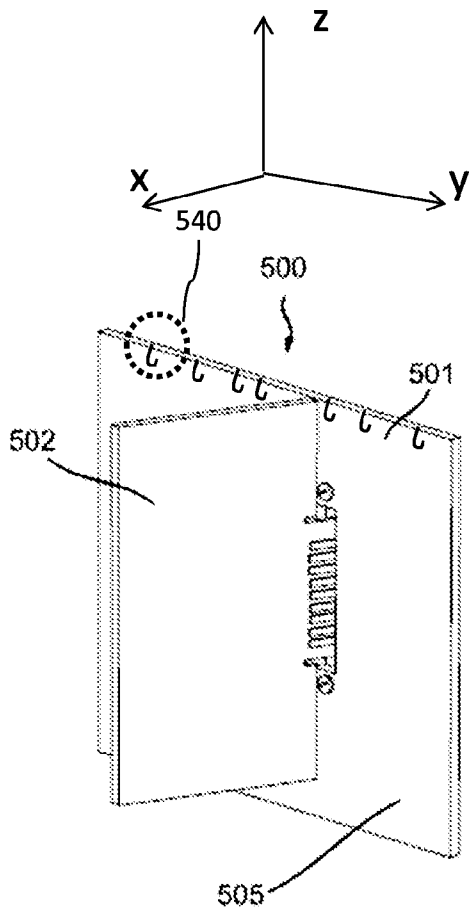

FIG. 22

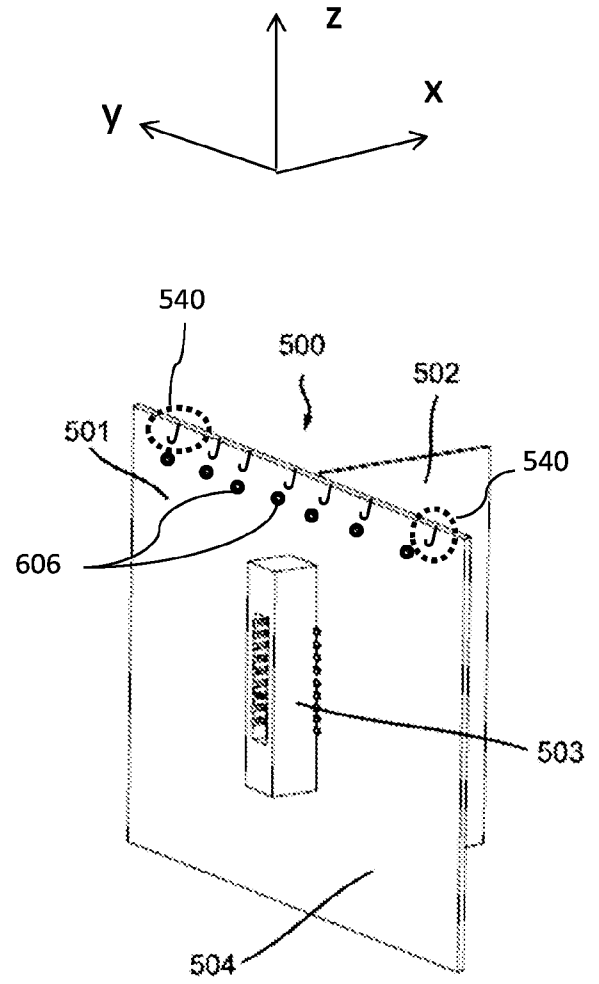

FIG. 23

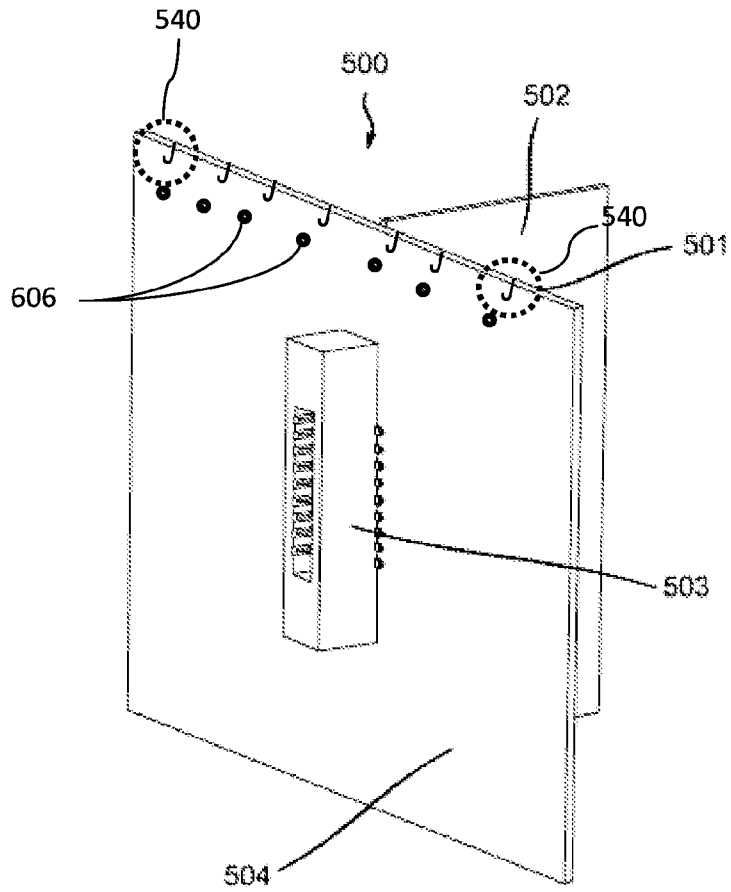

FIG. 24

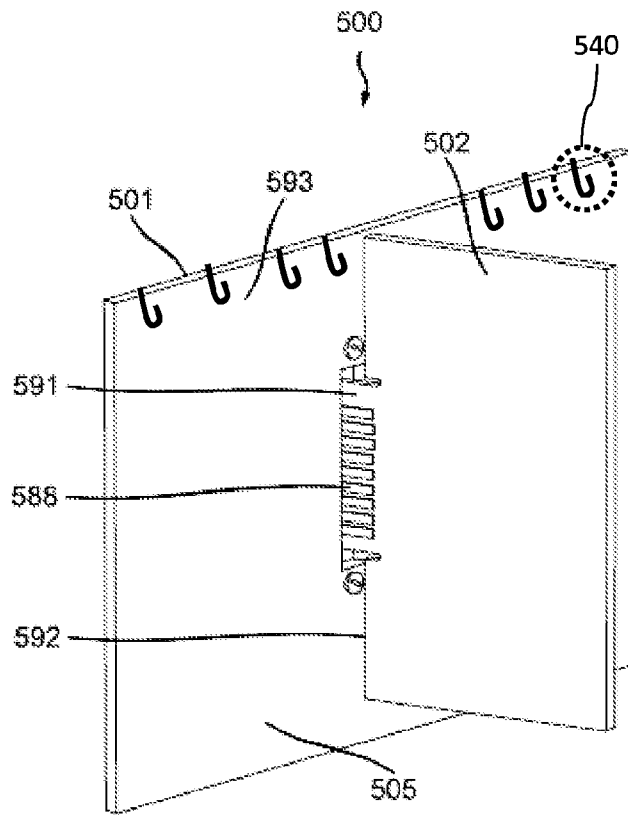

FIG. 25

19/33

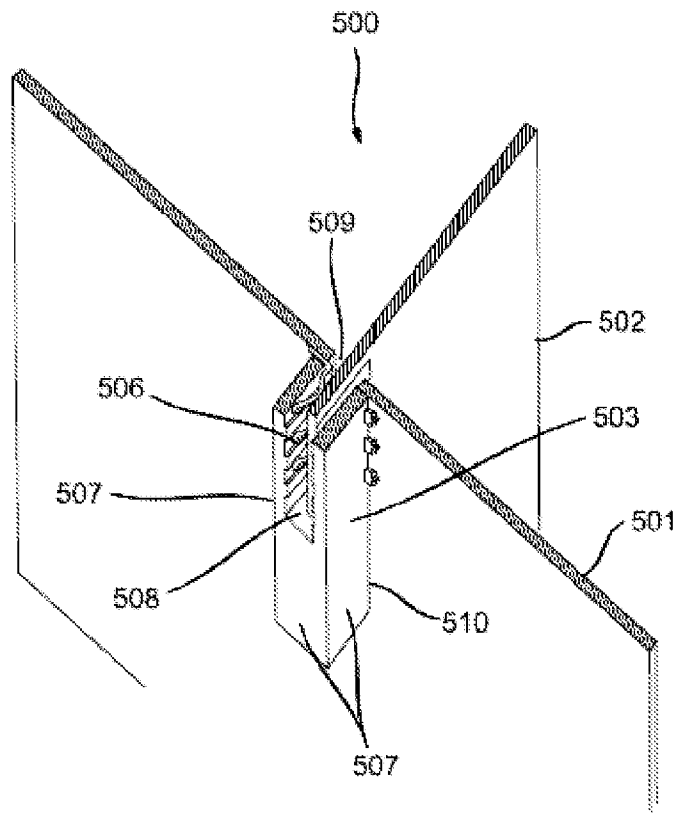

FIG. 26



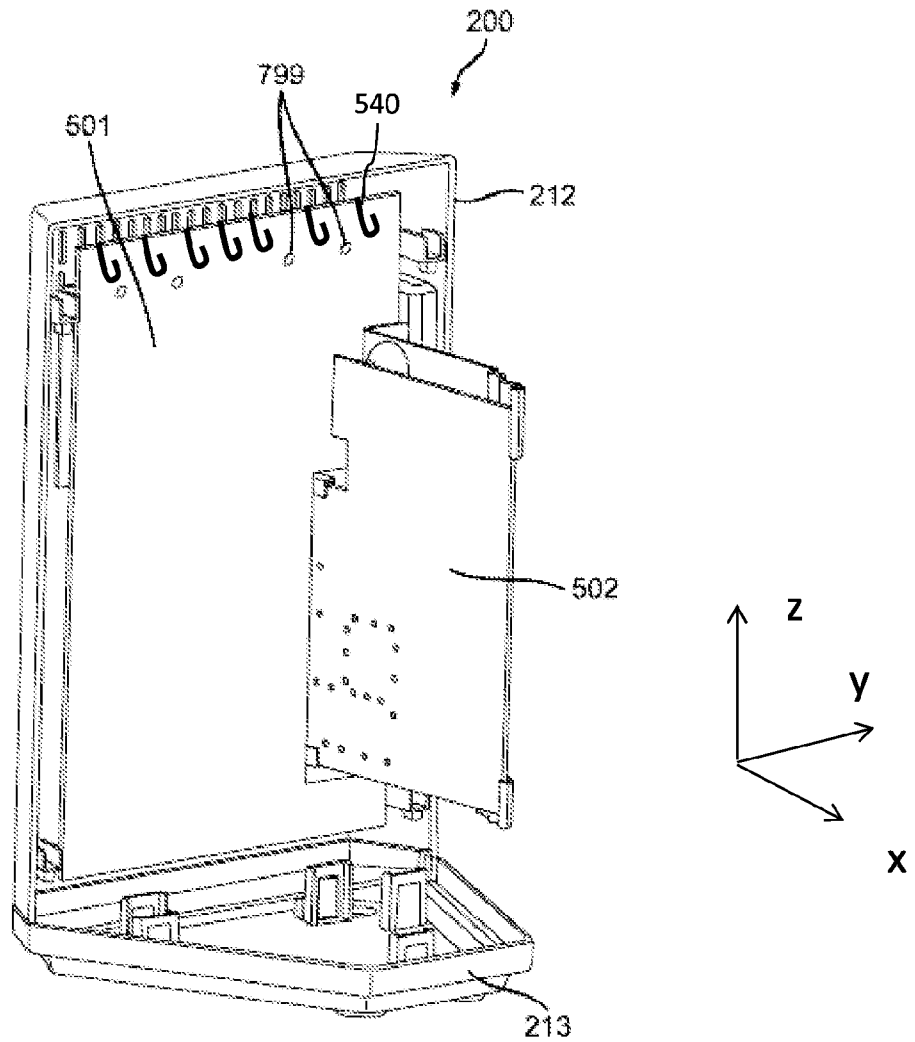

FIG. 27

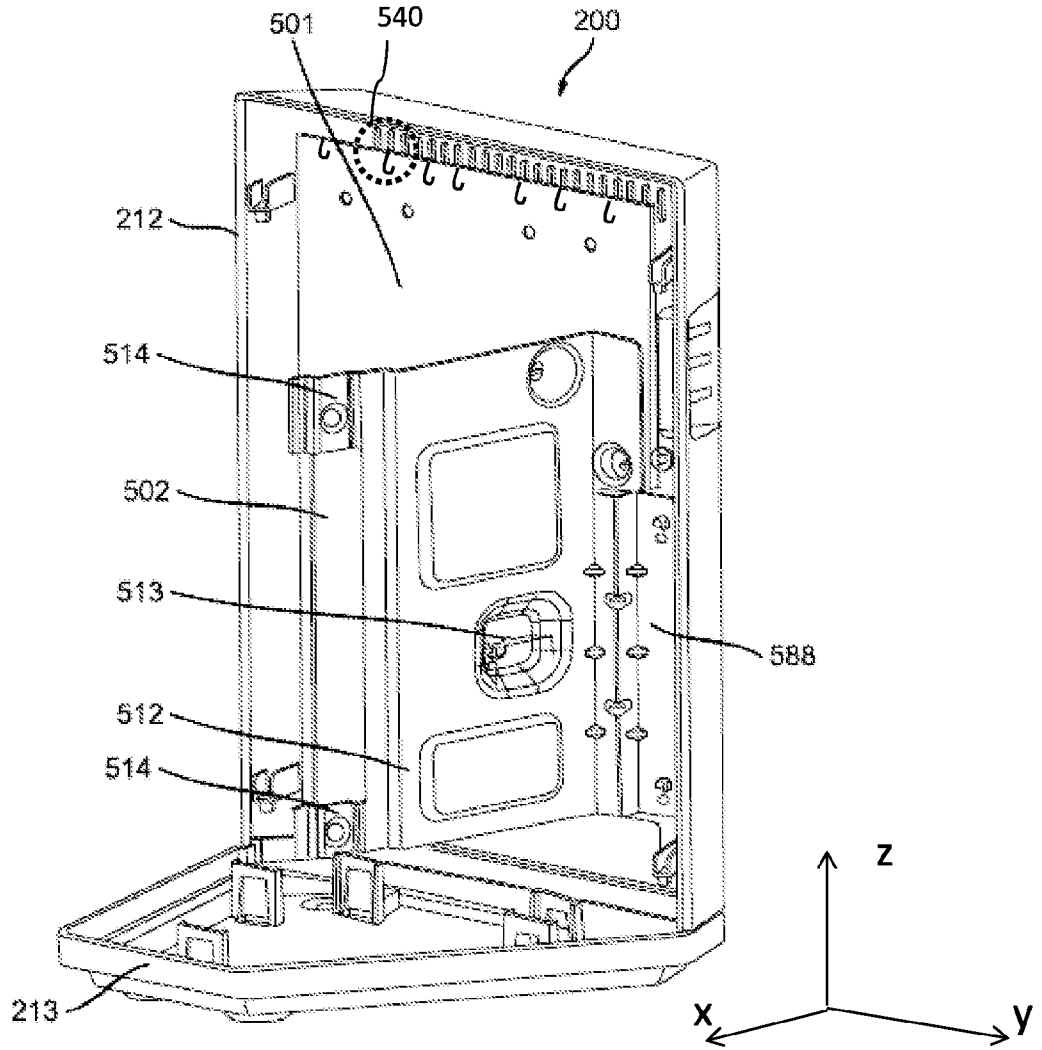

FIG. 28

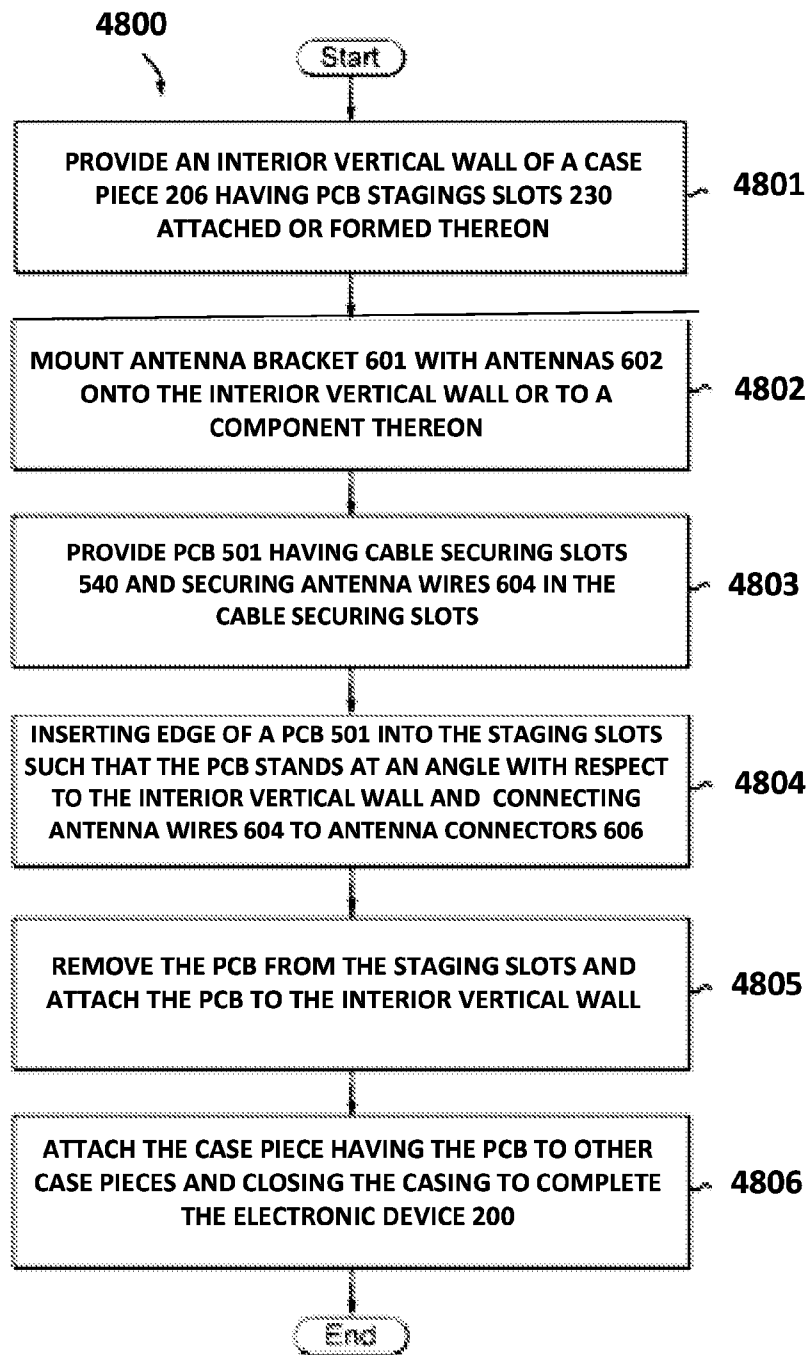

FIG. 29

23/33

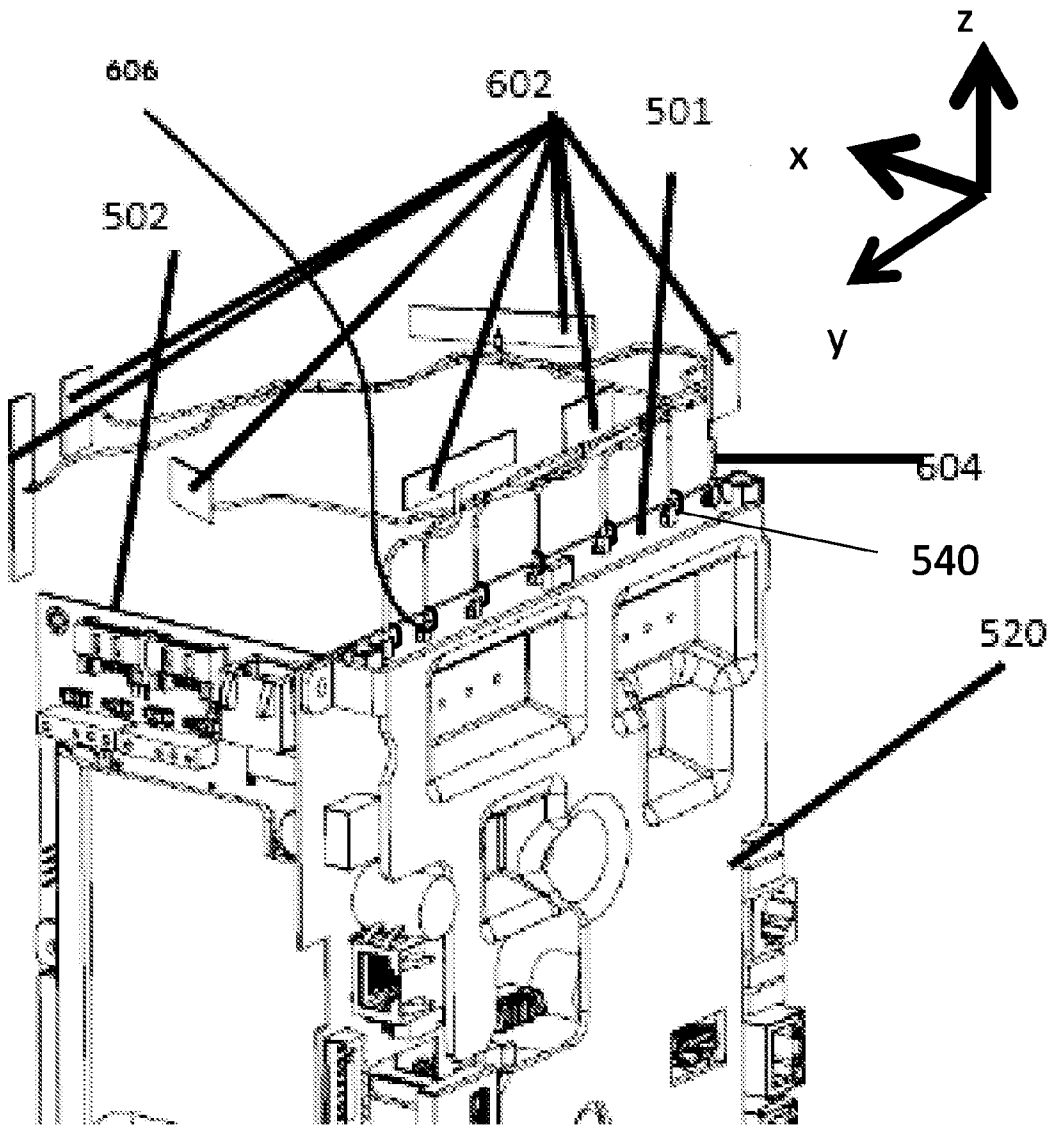

FIG. 30

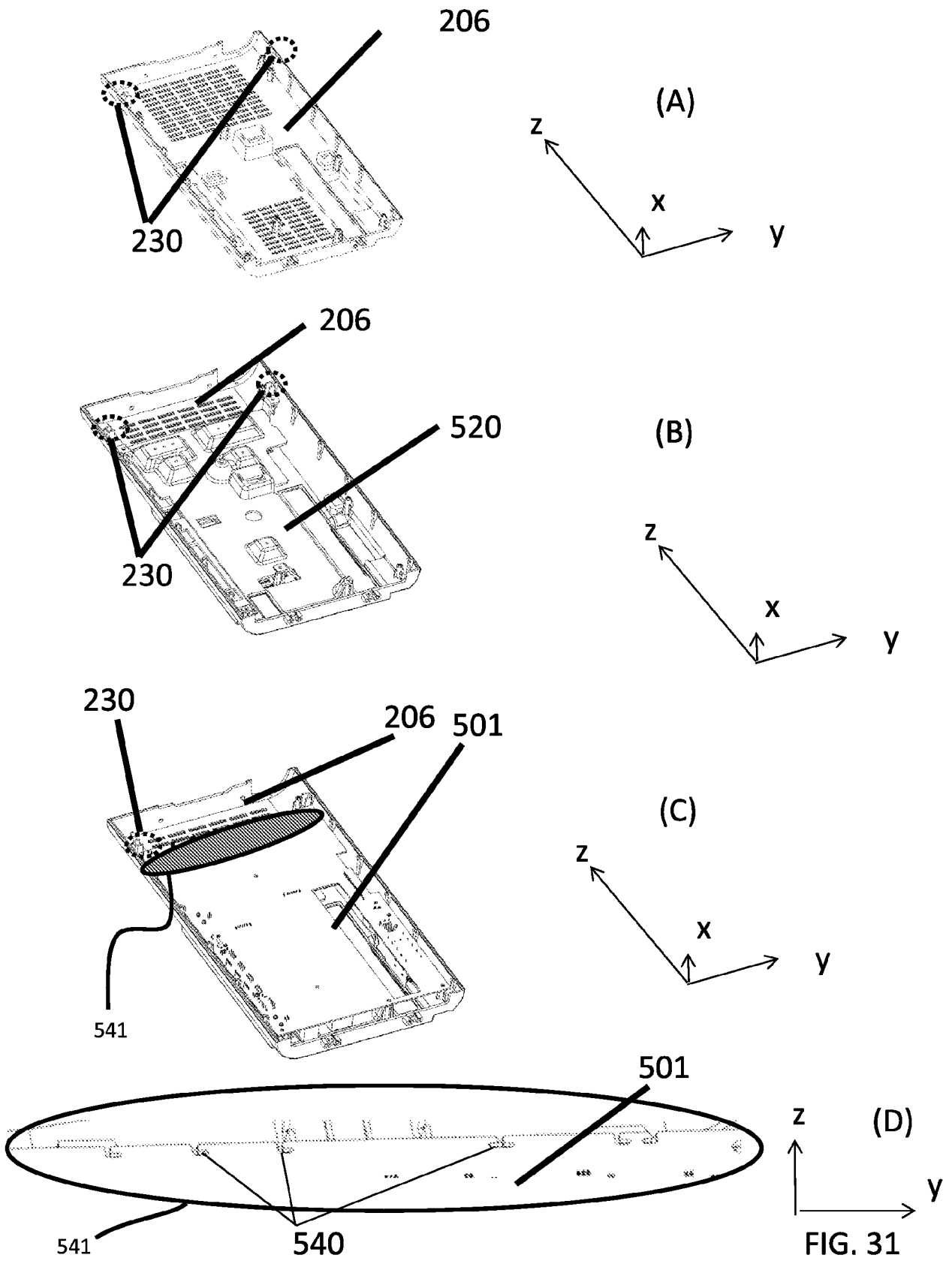

FIG. 31

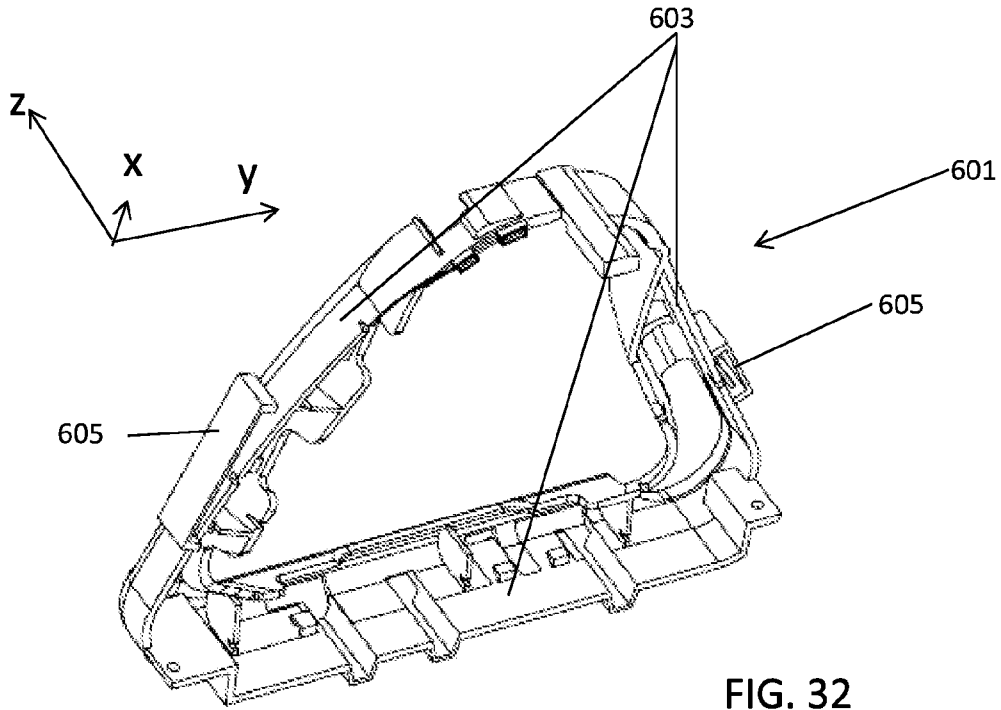

FIG. 32

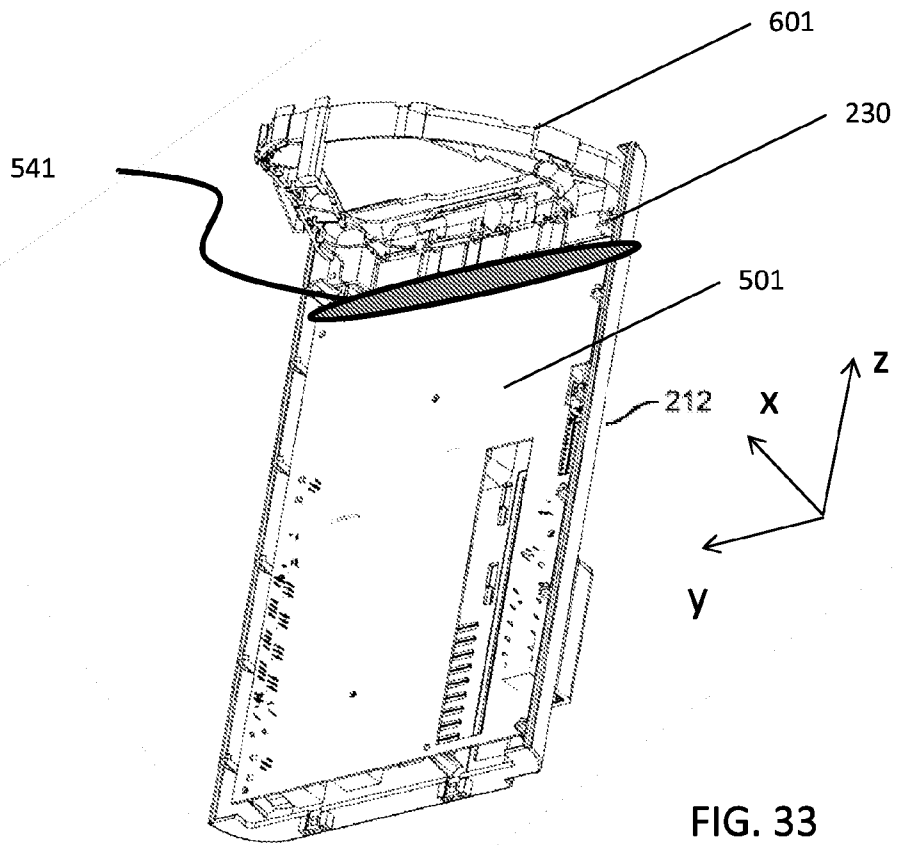

FIG. 33

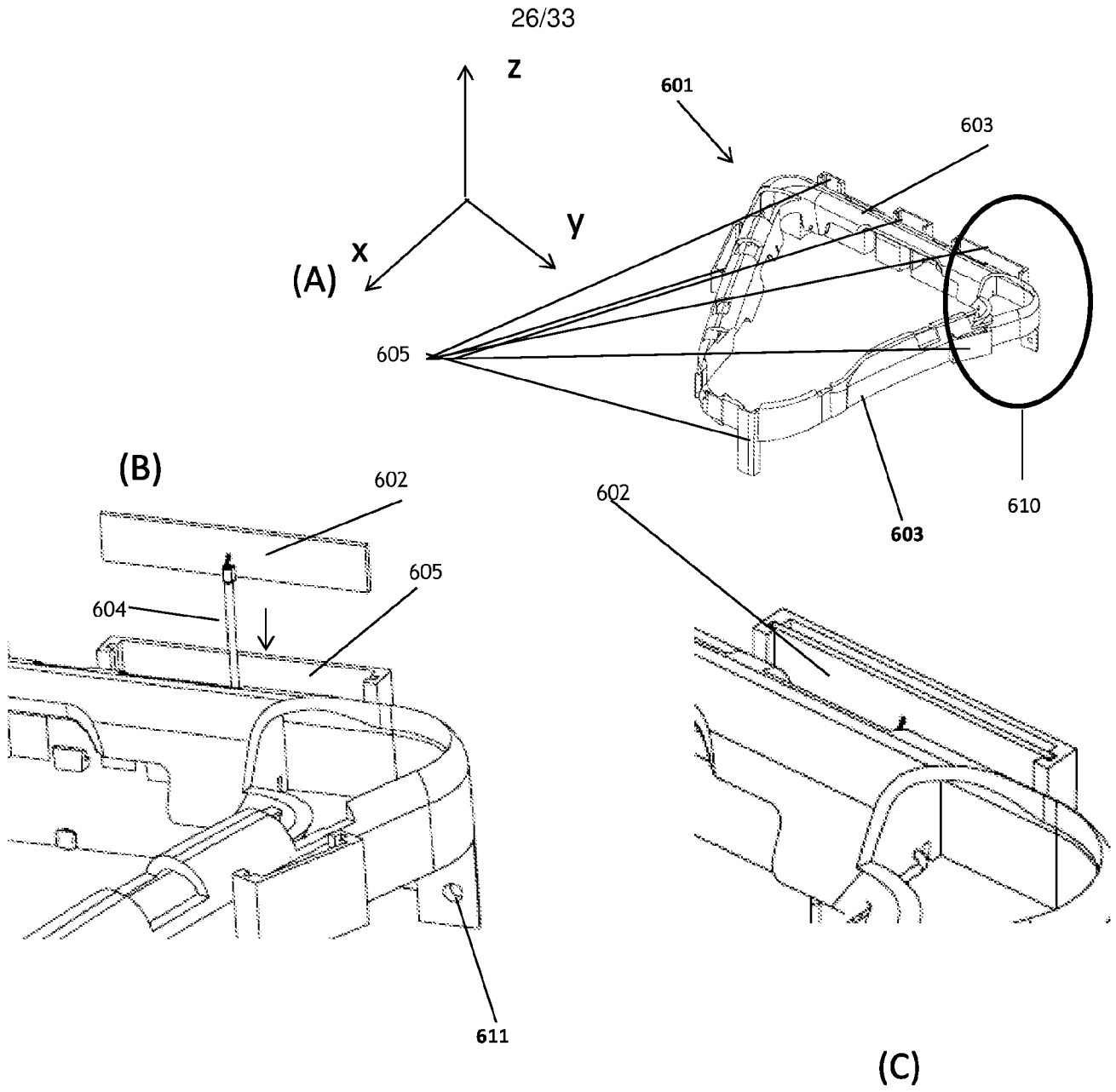

FIG. 34

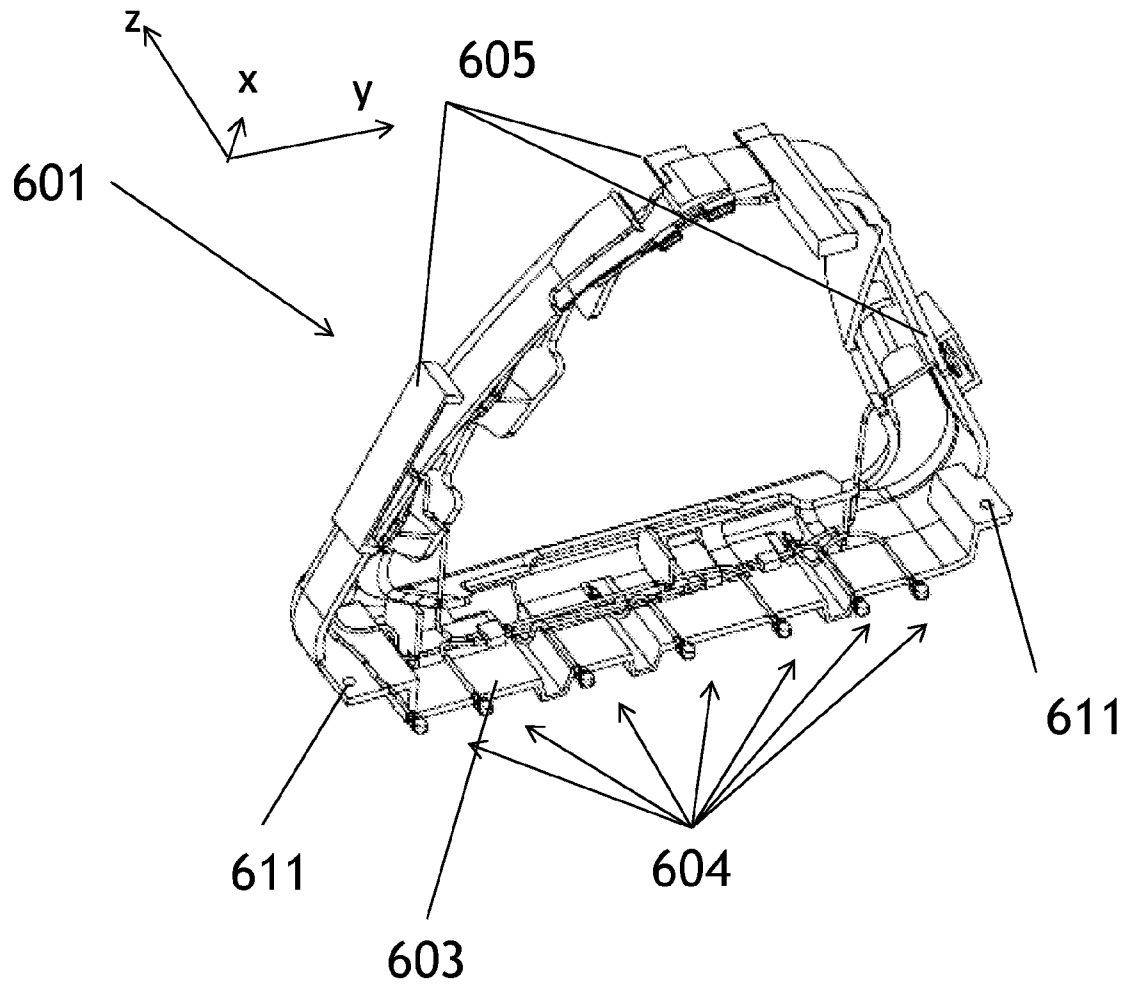

FIG. 35



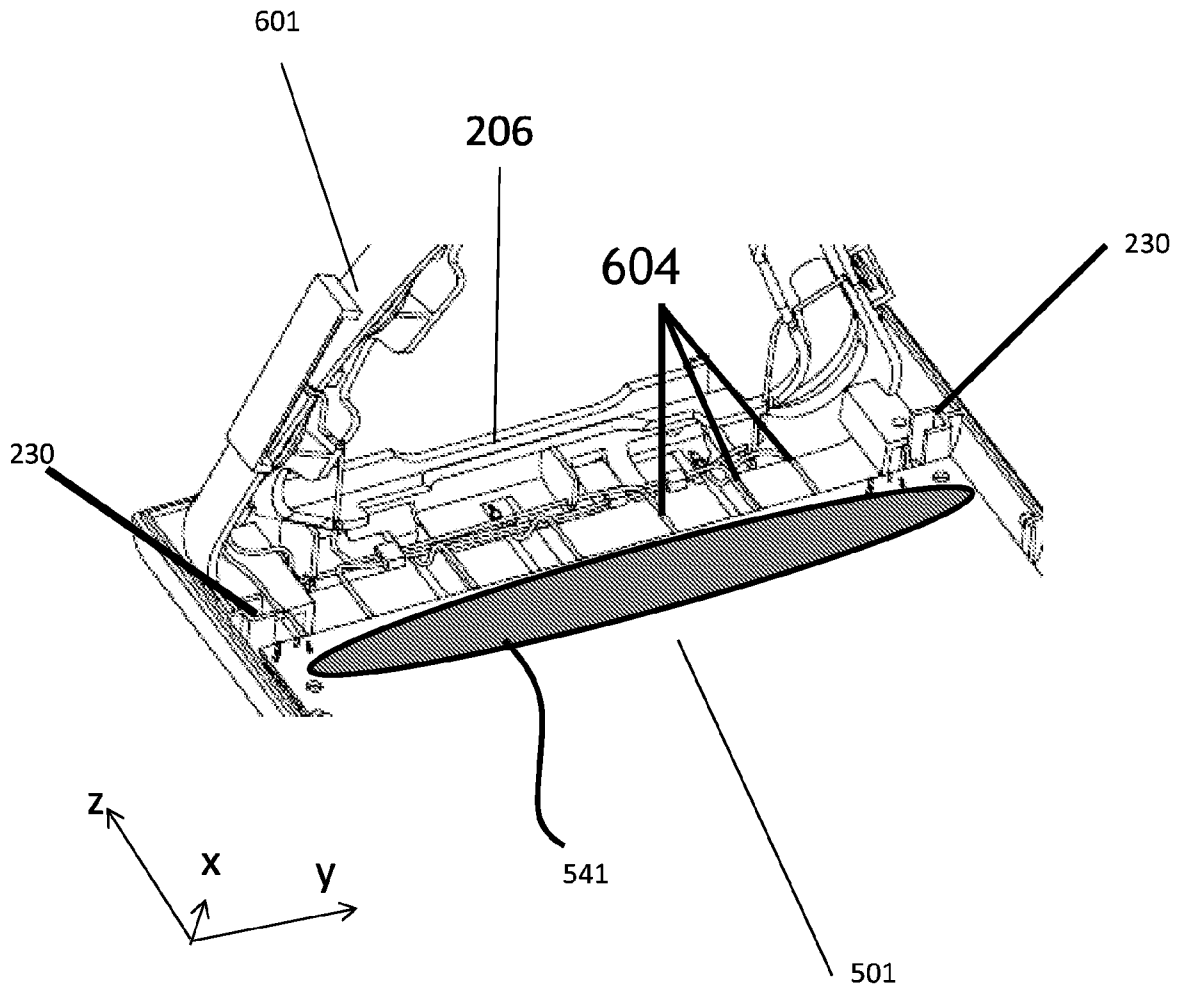

FIG. 36

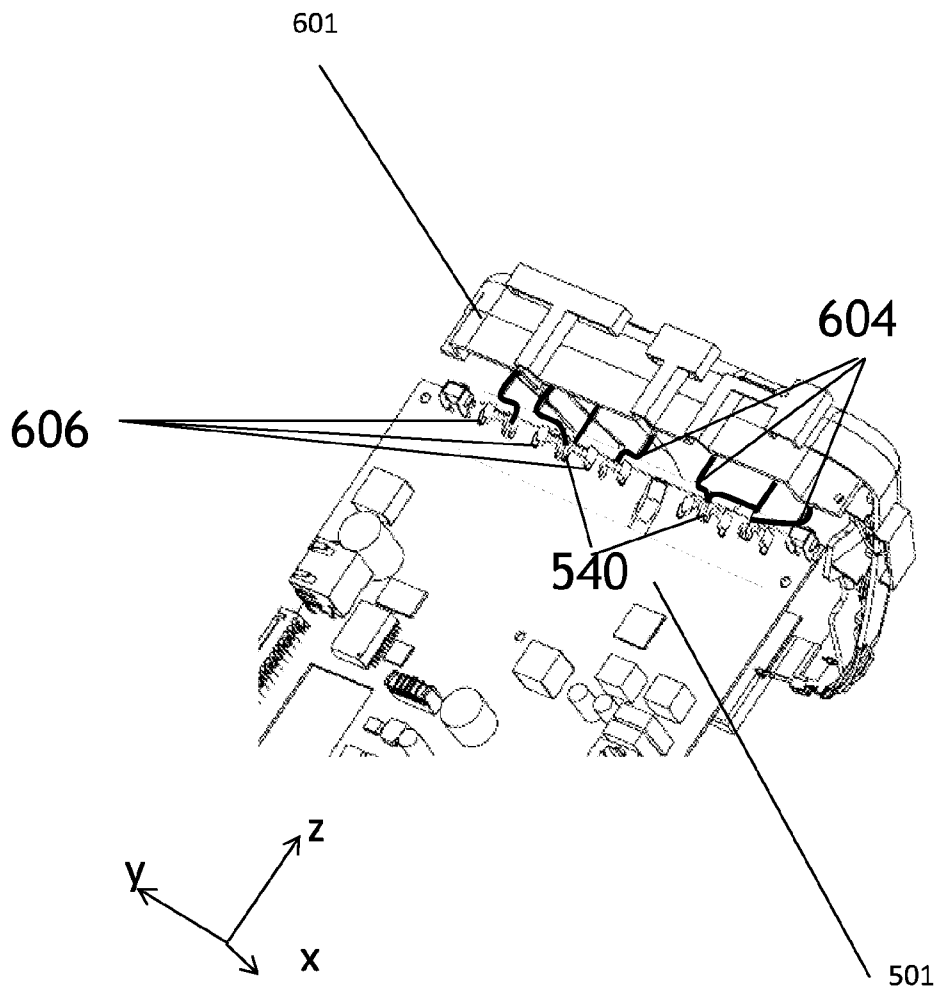
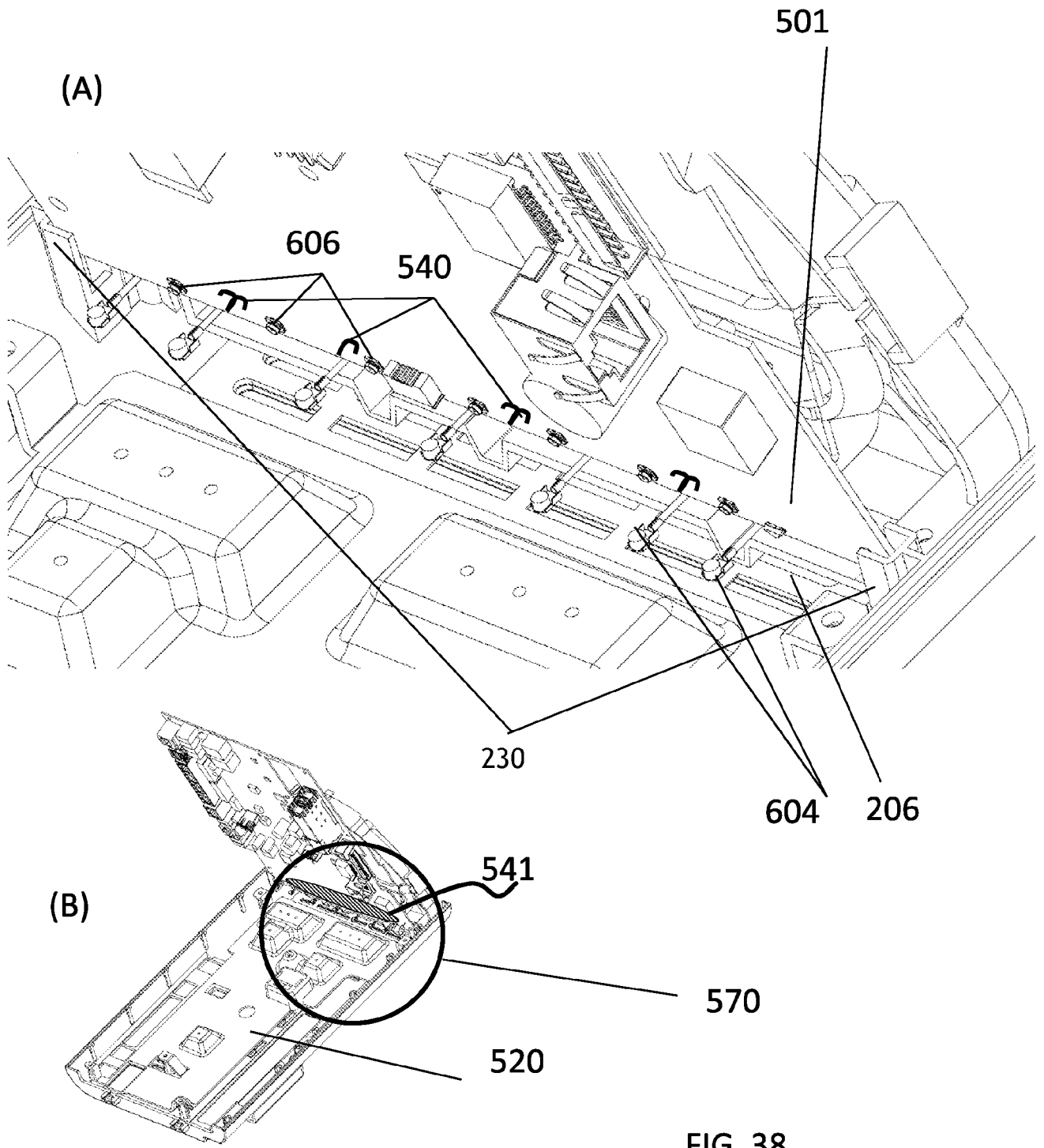

FIG. 37



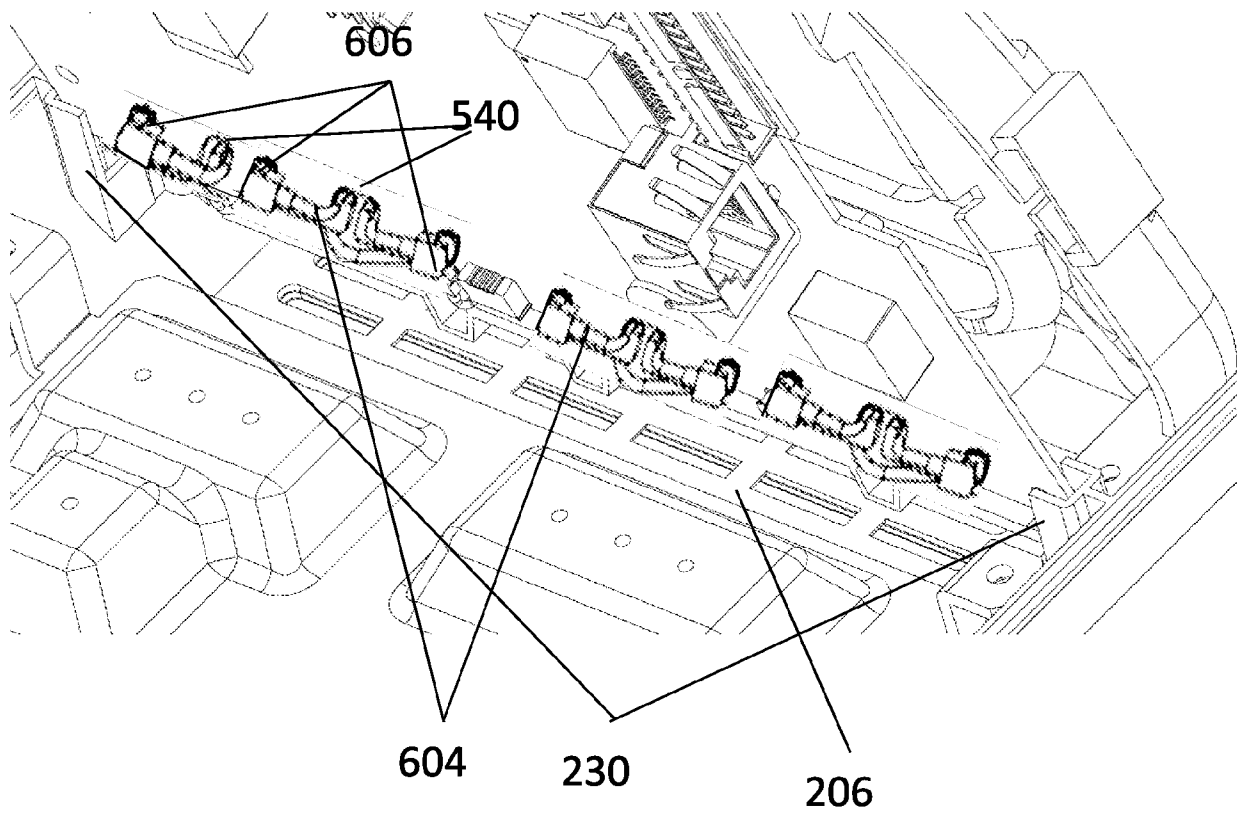

FIG. 39

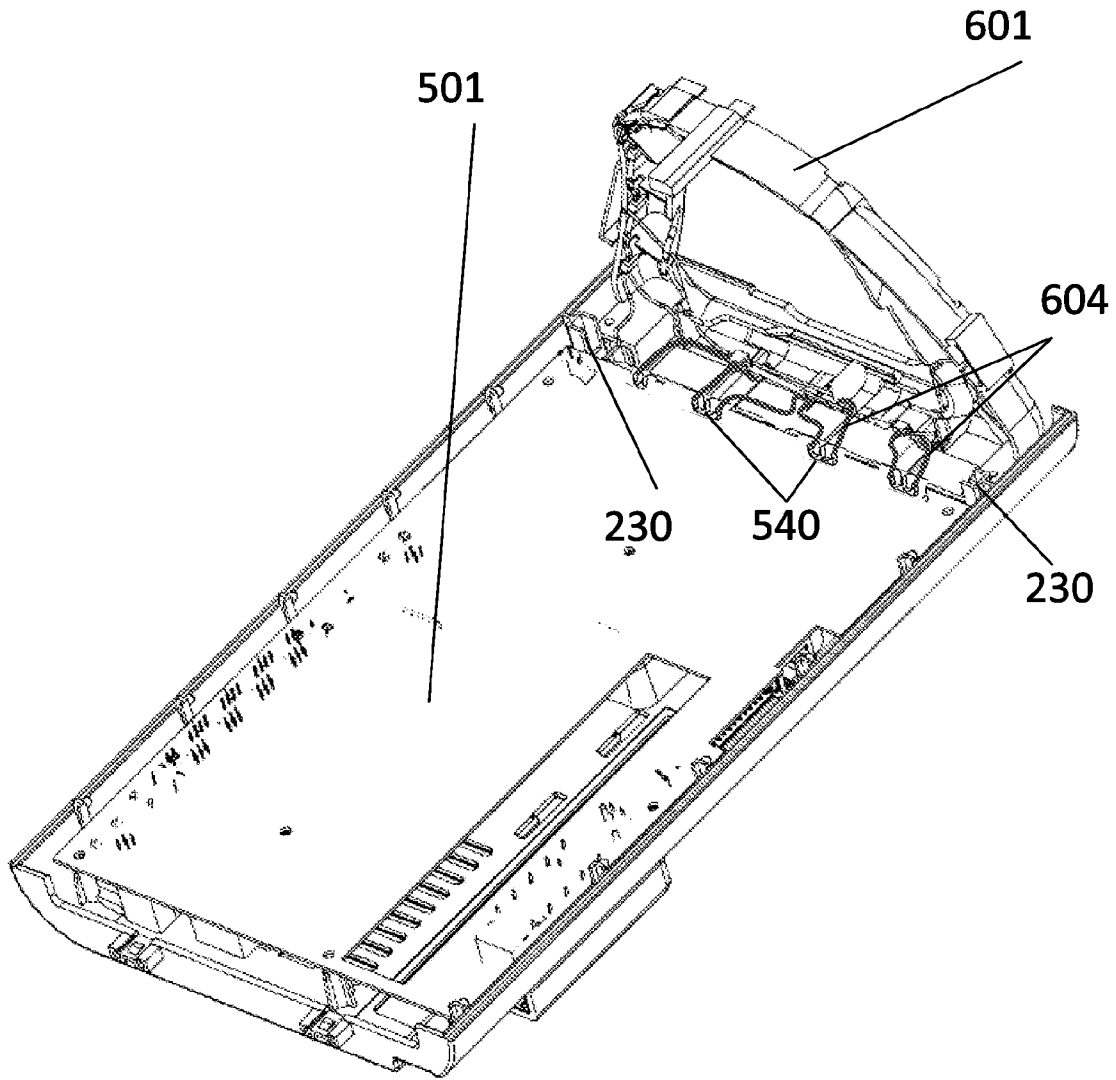

FIG. 40

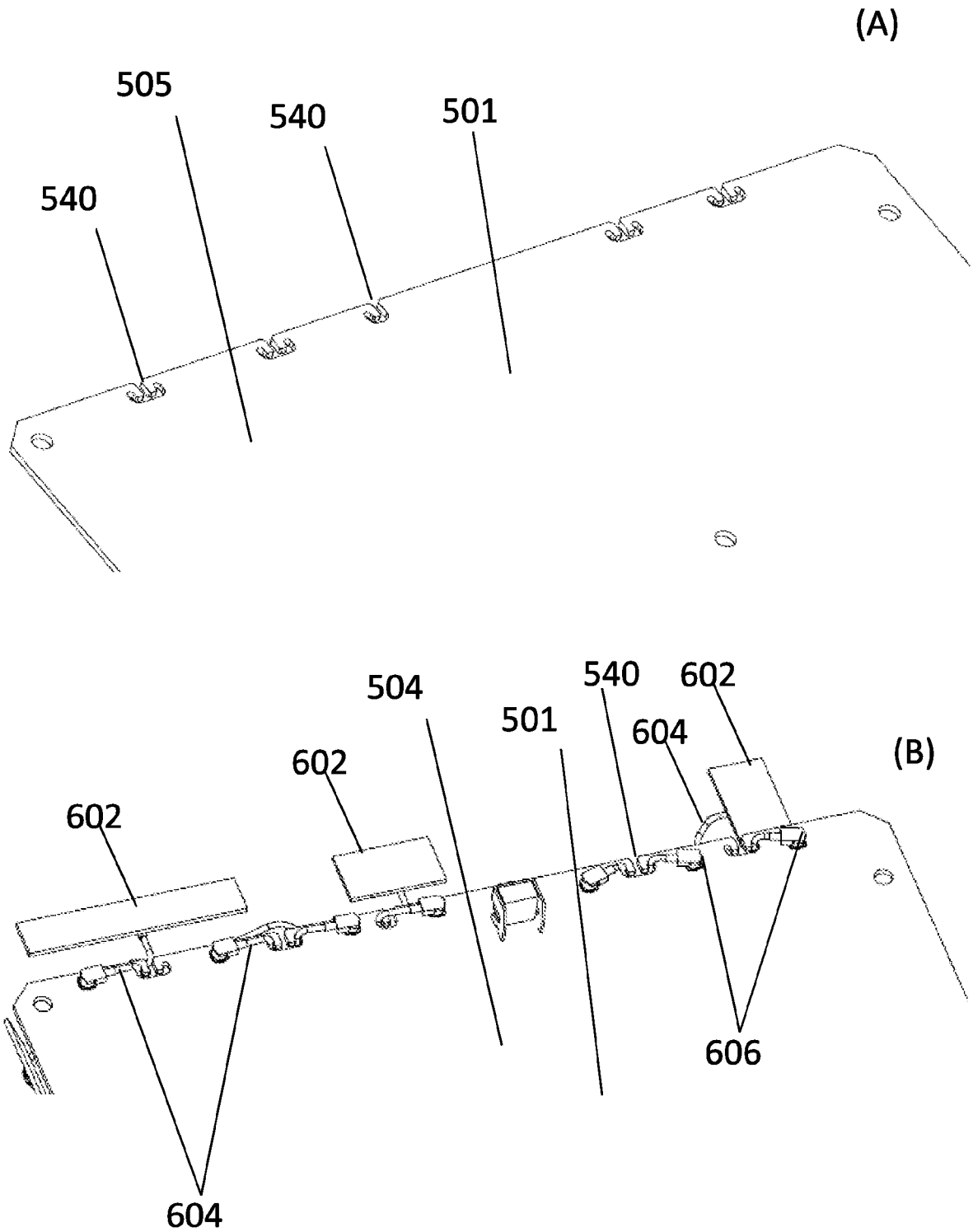

FIG. 41

INTERNATIONAL SEARCH REPORT

International application No.  
PCT/US2015/050583

<p><b>A. CLASSIFICATION OF SUBJECT MATTER</b>                  IPC(8) - H01Q 1/24 (2015.01)                  CPC - H01Q 1/243 (2015.10)                  According to International Patent Classification (IPC) or to both national classification and IPC</p>																										
<p><b>B. FIELDS SEARCHED</b></p> <p>Minimum documentation searched (classification system followed by classification symbols)                  IPC(8) - H01Q 1/24 (2015.01)                  USPC - 343/702, 718, 720, 725, 729, 767, 770, 776, 814, 826, 845, 846</p> <p>Documentation searched other than minimum documentation to the extent that such documents are included in the fields searched                  CPC - H01Q 1/38, 1/242, 1/243, 1/244, 9/0421 (2015.10) (keyword delimited)</p> <p>Electronic data base consulted during the international search (name of data base and, where practicable, search terms used)                  Orbit, Google Patents, Google Scholar, Google.                  Search terms used: pcb, circuit board, secure, fastening, attach, mount, slot, slit, opening, channel, ditch, cavity, antenna, wire, bracket, frame, support, set top box, gateway, internet, wireless, computer, housing, enclosure, polygonal, pocket, socket, vertical</p>																										
<p><b>C. DOCUMENTS CONSIDERED TO BE RELEVANT</b></p> <table border="1"> <thead> <tr> <th>Category*</th> <th>Citation of document, with indication, where appropriate, of the relevant passages</th> <th>Relevant to claim No.</th> </tr> </thead> <tbody> <tr> <td>X ----- Y</td> <td>✓ CN101808461 A (BEIJING VAST DIGITAL CO LTD) 18 August 2010 (18.08.2010) see machine translation</td> <td>1, 4, 5 ----- 2-3, 6-24</td> </tr> <tr> <td>Y</td> <td>✓ CN204119658 U (SHENZHEN GONGJIN ELECTRONIC CO) 21 January 2015 (21.01.2015) see machine translation</td> <td>2, 3, 6, 13, 14, 16, 24</td> </tr> <tr> <td>Y</td> <td>US 6,456,242 B1 (CRAWFORD) 24 September 2002 (24.09.2002) entire document</td> <td>6-24</td> </tr> <tr> <td>A</td> <td>US 8,344,950 B2 (SU) 01 January 2013 (01.01.2013) entire document</td> <td>1-24</td> </tr> <tr> <td>A</td> <td>US 2013/0162499 A1 (POCHOP et al.) 27 June 2013 (27.06.2013) entire document</td> <td>1-24</td> </tr> <tr> <td>A</td> <td>US 2012/0086553 A1 (WILKINSON et al.) 12 April 2012 (.04.2012) entire document</td> <td>1-24</td> </tr> <tr> <td>A</td> <td>US 7,365,697 B2 (NAITO) 29 April 2008 (29.04.2008) entire document</td> <td>1-24</td> </tr> </tbody> </table>			Category*	Citation of document, with indication, where appropriate, of the relevant passages	Relevant to claim No.	X ----- Y	✓ CN101808461 A (BEIJING VAST DIGITAL CO LTD) 18 August 2010 (18.08.2010) see machine translation	1, 4, 5 ----- 2-3, 6-24	Y	✓ CN204119658 U (SHENZHEN GONGJIN ELECTRONIC CO) 21 January 2015 (21.01.2015) see machine translation	2, 3, 6, 13, 14, 16, 24	Y	US 6,456,242 B1 (CRAWFORD) 24 September 2002 (24.09.2002) entire document	6-24	A	US 8,344,950 B2 (SU) 01 January 2013 (01.01.2013) entire document	1-24	A	US 2013/0162499 A1 (POCHOP et al.) 27 June 2013 (27.06.2013) entire document	1-24	A	US 2012/0086553 A1 (WILKINSON et al.) 12 April 2012 (.04.2012) entire document	1-24	A	US 7,365,697 B2 (NAITO) 29 April 2008 (29.04.2008) entire document	1-24
Category*	Citation of document, with indication, where appropriate, of the relevant passages	Relevant to claim No.																								
X ----- Y	✓ CN101808461 A (BEIJING VAST DIGITAL CO LTD) 18 August 2010 (18.08.2010) see machine translation	1, 4, 5 ----- 2-3, 6-24																								
Y	✓ CN204119658 U (SHENZHEN GONGJIN ELECTRONIC CO) 21 January 2015 (21.01.2015) see machine translation	2, 3, 6, 13, 14, 16, 24																								
Y	US 6,456,242 B1 (CRAWFORD) 24 September 2002 (24.09.2002) entire document	6-24																								
A	US 8,344,950 B2 (SU) 01 January 2013 (01.01.2013) entire document	1-24																								
A	US 2013/0162499 A1 (POCHOP et al.) 27 June 2013 (27.06.2013) entire document	1-24																								
A	US 2012/0086553 A1 (WILKINSON et al.) 12 April 2012 (.04.2012) entire document	1-24																								
A	US 7,365,697 B2 (NAITO) 29 April 2008 (29.04.2008) entire document	1-24																								
<p><input type="checkbox"/> Further documents are listed in the continuation of Box C.      <input type="checkbox"/> See patent family annex.</p>																										
<p>* Special categories of cited documents:</p> <table border="0"> <tr> <td>"A" document defining the general state of the art which is not considered to be of particular relevance</td> <td>"T" later document published after the international filing date or priority date and not in conflict with the application but cited to understand the principle or theory underlying the invention</td> </tr> <tr> <td>"E" earlier application or patent but published on or after the international filing date</td> <td>"X" document of particular relevance; the claimed invention cannot be considered novel or cannot be considered to involve an inventive step when the document is taken alone</td> </tr> <tr> <td>"L" document which may throw doubts on priority claim(s) or which is cited to establish the publication date of another citation or other special reason (as specified)</td> <td>"Y" document of particular relevance; the claimed invention cannot be considered to involve an inventive step when the document is combined with one or more other such documents, such combination being obvious to a person skilled in the art</td> </tr> <tr> <td>"O" document referring to an oral disclosure, use, exhibition or other means</td> <td>"&amp;" document member of the same patent family</td> </tr> <tr> <td>"P" document published prior to the international filing date but later than the priority date claimed</td> <td></td> </tr> </table>			"A" document defining the general state of the art which is not considered to be of particular relevance	"T" later document published after the international filing date or priority date and not in conflict with the application but cited to understand the principle or theory underlying the invention	"E" earlier application or patent but published on or after the international filing date	"X" document of particular relevance; the claimed invention cannot be considered novel or cannot be considered to involve an inventive step when the document is taken alone	"L" document which may throw doubts on priority claim(s) or which is cited to establish the publication date of another citation or other special reason (as specified)	"Y" document of particular relevance; the claimed invention cannot be considered to involve an inventive step when the document is combined with one or more other such documents, such combination being obvious to a person skilled in the art	"O" document referring to an oral disclosure, use, exhibition or other means	"&" document member of the same patent family	"P" document published prior to the international filing date but later than the priority date claimed															
"A" document defining the general state of the art which is not considered to be of particular relevance	"T" later document published after the international filing date or priority date and not in conflict with the application but cited to understand the principle or theory underlying the invention																									
"E" earlier application or patent but published on or after the international filing date	"X" document of particular relevance; the claimed invention cannot be considered novel or cannot be considered to involve an inventive step when the document is taken alone																									
"L" document which may throw doubts on priority claim(s) or which is cited to establish the publication date of another citation or other special reason (as specified)	"Y" document of particular relevance; the claimed invention cannot be considered to involve an inventive step when the document is combined with one or more other such documents, such combination being obvious to a person skilled in the art																									
"O" document referring to an oral disclosure, use, exhibition or other means	"&" document member of the same patent family																									
"P" document published prior to the international filing date but later than the priority date claimed																										
<p>Date of the actual completion of the international search 29 October 2015</p>		<p>Date of mailing of the international search report <b>04 DEC 2015</b></p>																								
<p>Name and mailing address of the ISA/                  Mail Stop PCT, Attn: ISA/US, Commissioner for Patents                  P.O. Box 1450, Alexandria, Virginia 22313-1450                  Facsimile No. 571-273-8300</p>		<p>Authorized officer                  Blaine Copenheaver                  PCT Helpdesk: 571-272-4300                  PCT OSP: 571-272-7774</p>																								