



(51) International Patent Classification:
A63F 13/12 (2006.01)

(21) International Application Number:
PCT/US2012/043617

(22) International Filing Date:
21 June 2012 (21.06.2012)

(25) Filing Language: English

(26) Publication Language: English

(71) Applicant (for all designated States except US): **KONAMI GAMING, INCORPORATED** [US/US]; 585 Trade Center Drive, Las Vegas, NV 89119 (US).

(72) Inventors; and

(75) Inventors/Applicants (for US only): **OKUAKI, Masato** [JP/JP]; c/o Konami Gaming, Incorporated, Japan Branch, 5-1-1, Higashihara, Zama-shi, Kanagawa, 252-0004 (JP). **INOUE, Atsushi** [JP/JP]; c/o Konami Gaming, Incorporated, Japan Branch, 5-1-1, Higashihara, Zama-shi, Kanagawa, 252-0004 (JP). **SHIMIZU, Toshiaki** [JP/JP]; c/o Konami Gaming, Incorporated, Japan Branch, 5-1-1, Higashihara, Zama-shi, Kanagawa, 252-0004 (JP). **HIRAI, Tomoaki** [JP/JP]; c/o Konami Gaming, Incorporated, Japan Branch, 5-1-1, Higashihara, Zama-shi, Kanagawa, 252-0004 (JP). **SAZAKI, Taisuke** [JP/JP]; c/o Konami

Gaming, Incorporated, Japan Branch, 5-1-1, Higashihara, Zama-shi, Kanagawa, 252-0004 (JP).

(74) Agents: **YEE, James, R.** et al.; Howard & Howard Attorneys PLLC, 450 West Fourth Street, Royal Oak, MI 48067 (US).

(81) Designated States (unless otherwise indicated, for every kind of national protection available): AE, AG, AL, AM, AO, AT, AU, AZ, BA, BB, BG, BH, BR, BW, BY, BZ, CA, CH, CL, CN, CO, CR, CU, CZ, DE, DK, DM, DO, DZ, EC, EE, EG, ES, FI, GB, GD, GE, GH, GM, GT, HN, HR, HU, ID, IL, IN, IS, JP, KE, KG, KM, KN, KP, KR, KZ, LA, LC, LK, LR, LS, LT, LU, LY, MA, MD, ME, MG, MK, MN, MW, MX, MY, MZ, NA, NG, NI, NO, NZ, OM, PE, PG, PH, PL, PT, QA, RO, RS, RU, RW, SC, SD, SE, SG, SK, SL, SM, ST, SV, SY, TH, TJ, TM, TN, TR, TT, TZ, UA, UG, US, UZ, VC, VN, ZA, ZM, ZW.

(84) Designated States (unless otherwise indicated, for every kind of regional protection available): ARIPO (BW, GH, GM, KE, LR, LS, MW, MZ, NA, RW, SD, SL, SZ, TZ, UG, ZM, ZW), Eurasian (AM, AZ, BY, KG, KZ, RU, TJ, TM), European (AL, AT, BE, BG, CH, CY, CZ, DE, DK, EE, ES, FI, FR, GB, GR, HR, HU, IE, IS, IT, LT, LU, LV, MC, MK, MT, NL, NO, PL, PT, RO, RS, SE, SI, SK, SM, TR), OAPI (BF, BJ, CF, CG, CI, CM, GA, GN, GQ, GW, ML, MR, NE, SN, TD, TG).

[Continued on next page]

(54) Title: GAME MACHINE, CONTROL METHOD OF CONTROLLING COMPUTER, COMPUTER PROGRAM, AND LAYOUT SETTING METHOD

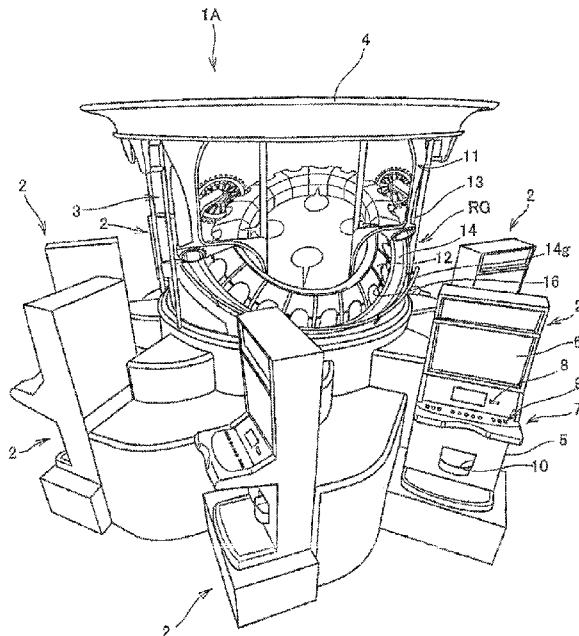

Fig. 1

(57) Abstract: A game machine (1A) includes: a first game unit (3a) that provides a first game in a predetermined use direction (S); at least one second game unit (2) that is arranged around the first game unit (3a) and provides a second game related to the first game; a rotary drive device (24) that rotates the first game unit (3 a) so that the predetermined use direction (S) faces a direction of the second game unit (2) at least once. And, the game machine (1A) acquires positional information for specifying a position of the second game unit (2) during rotation of the first game unit (3a), determines a position of them based on the positional information and, controls the rotary drive device (24) such that the predetermined use direction (S) faces the direction of the second game unit when the first game unit (3 a) provides the first game.

WO 2013/191702 A1

Published:

— *with international search report (Art. 21(3))*

**GAME MACHINE, CONTROL METHOD OF CONTROLLING
COMPUTER, COMPUTER PROGRAM, AND LAYOUT SETTING METHOD**

Technical Field

[0001] The present invention relates to a game machine or the like including a first game unit that provides a first game and a second game unit that provides a second game related to the first game.

Background Art

[0002] A game machine has been known that includes a center unit providing a center game, satellite units each providing an opportunity to play a center game, and station units each providing an opportunity to play a satellite unit (for example, see Patent Literature 1).
Patent Literature 1: Japanese Patent No. 4331173.

Summary of Invention

Technical Problem

[0003] In the game machine disclosed in Patent Literature 1, each satellite unit provides each corresponding station unit with a game. For this reason, it is desirable to arrange each satellite unit and each corresponding station unit with a predetermined positional relation. This is similarly applied to a relation between the satellite unit and the center unit. For this reason, it takes time to arrange the units. Further, the layout becomes limited.

[0004] In this regard, it is an object of the present invention to provide a game machine, a control method of controlling a computer, a computer program and, a layout setting method, which are capable of easily arranging a first game unit and a second game unit.

[0005] In order to solve the above problems, a game machine of the present invention comprises: a first game unit that provides a first game in a predetermined use direction; at least one second game unit that is arranged around the first game unit and provides a second game related to the first game; a rotary drive device that rotates the first game unit so that the predetermined use direction faces a direction of the second game unit at least once; a positional information acquiring device that acquires positional information for specifying a position of the second game unit during rotation of the first game unit; a position determining device that determines a position of the second game unit based on the positional information acquired by the positional information acquiring device; and a rotation control device that controls the rotary drive device based on a determination result of the position determining device such that the rotary drive device rotates the first game unit and the predetermined use direction faces the direction of the second game unit when the first game unit provides the first game.

[0006] According to the present invention, layout information of the second game unit is acquired during rotation of the first game unit, and the position of the second game unit is determined based on the layout information. Based on the determination result, rotation of the first game unit is controlled such that the use direction faces a direction of the second game unit to which the first game should be provided. In other words, the position of the second game unit is acquired based on an installation result, and the use direction of the first game unit is adjusted based on the acquisition result. For this reason, the second

game unit can be arbitrarily arranged around the first game unit to the extent that the direction of the second game unit matches the use direction. Thus, a positional relation between the first game unit and the second game unit does not need to be considered at the time of the layout. Accordingly, the first game unit and the second game unit can be easily arranged.

[0007] Also, in order to solve the above problems, a control method of controlling a computer of the present invention is a control method of controlling a computer incorporated into a game machine comprising: a first game unit that provides a first game in a predetermined use direction; at least one second game unit that is arranged around the first game unit and provides a second game related to the first game; a rotary drive device that rotates the first game unit so that the predetermined use direction faces a direction of the second game unit at least once, and wherein the control method of controlling the computer comprises the steps: a positional information acquiring step that acquires positional information for specifying a position of the second game unit during rotation of the first game unit; a position determining step that determines a position of the second game unit based on the positional information acquired by the positional information acquiring step; and a rotation control step that controls the rotary drive device based on a determination result of the position determining step such that the rotary drive device rotates the first game unit and the predetermined use direction faces the direction of the second game unit when the first game unit provides the first game.

[0008] Further, in order to solve the above problems, a computer program for a game machine of the present invention is a computer program for a game machine being configured to cause a computer, which is incorporated into a game machine comprising: a

first game unit that provides a first game in a predetermined use direction; at least one second game unit that is arranged around the first game unit and provides a second game related to the first game; a rotary drive device that rotates the first game unit so that the predetermined use direction faces a direction of the second game unit at least once, to function as: a positional information acquiring device that acquires positional information for specifying a position of the second game unit during rotation of the first game unit; a position determining device that determines a position of the second game unit based on the positional information acquired by the positional information acquiring device; and a rotation control device that controls the rotary drive device based on a determination result of the position determining device such that the rotary drive device rotates the first game unit and the predetermined use direction faces the direction of the second game unit when the first game unit provides the first game. It is possible to actualize a game machine of the present invention by executing the computer program or the control method of controlling a computer of the present invention.

[0009] Furthermore, in order to solve the above problems, a layout setting method of the present invention is a layout setting method applied to a game machine comprising a first game unit that provides a first game in a predetermined use direction, at least one second game unit that is arranged around the first game unit and provides a second game related to the first game, and a rotary drive device that rotates the first game unit so that the predetermined use direction faces a direction of the second game unit at least once, wherein the layout setting method comprises the steps: a step that rotates the first game unit through the rotary drive device; and a position setting step that sets a position at

which the predetermined use direction faces the second game unit during rotation of the first game unit as a position of the second game unit.

Brief Description of Drawings

[0010] Fig. 1 is an external appearance diagram of a game machine according to a first embodiment of the present invention.

[0011] Fig. 2 is a schematic enlarged view of a center unit.

[0012] Fig. 3 is a schematic enlarged view of a base unit.

[0013] Fig. 4 is a functional block diagram illustrating a schematic configuration of a control system of the game machine according to the first embodiment.

[0014] Fig. 5 is a schematic plane view when a game machine is viewed from the top.

[0015] Fig. 6 is a flowchart illustrating the flow of a layout setting method.

[0016] Fig. 7 is a diagram illustrating an example of a layout check screen.

[0017] Fig. 8 is a diagram illustrating an example of content of station management data.

[0018] Fig. 9 is a diagram illustrating an example of a flowchart of a center unit moving process routine.

[0019] Fig. 10 is a functional block diagram illustrating a schematic configuration of a control system of a game machine according to a second embodiment.

[0020] Fig. 11 is a diagram illustrating an example of a flowchart of a layout setting process routine.

[0021] Fig. 12 is a diagram illustrating the layout of station units according to a first modified embodiment.

[0022] Fig. 13 is a diagram illustrating the layout of station units 2 according to a second modified embodiment.

Description of Embodiments

First Embodiment

[0023] Hereinafter, a game machine according to a first embodiment of the present invention will be described with reference to the accompanying drawings. Fig. 1 is an external appearance diagram of the game machine according to the first embodiment of the present invention. As illustrated in Fig. 1, a game machine 1A includes 8 station units 2 (only 7 units are illustrated in Fig. 1) as a second game unit, a center unit 3, and an outer unit 4. The outer unit 4 is positioned so as to surround the center unit 3 and interposed between each station unit 2 and the center unit 3. The 8 station units 2 are arranged around the center unit 3 with the outer unit 4 interposed therebetween. In addition, the number of station units 2 may be an appropriate number. For example, the number of station units 2 may be one.

[0024] The station unit 2 provides, for example, a slot game as a second game in exchange for consumption of coins as a game value. The slot game refers to a well-known game in which displays of symbols change according to a lottery result, and a predetermined privilege is given when a combination of changed displays of symbols forms a predetermined winning arrangement. The station unit 2 includes a housing 5. A station monitor 6 is disposed on a front surface of the housing 5. A game screen for executing a slot game is displayed on the station monitor 6. For example, a liquid crystal display device is used as the station monitor 6. A control panel 7 is disposed

below the station monitor 6. The control panel 7 includes a coin insertion slot 8 and an operation device 9. For example, the operation device 9 includes an operation member such as a button switch for performing various operations including a betting operation or the like. A coin-payout opening 10 is disposed below the control panel 7.

[0025] Meanwhile, the center unit 3 provides a so-called roulette game (an opportunity of a lottery) as a first game when a predetermined game condition is satisfied with the station unit 2. The roulette game refers to a well-known game that executes a lottery using a circular roulette wheel and a ball that rotationally moves along the outer circumference of the roulette wheel. Typically, the roulette wheel includes pockets for accommodating a ball, and the pockets are disposed along the outer circumference of the roulette wheel. And, a privilege is provided corresponding to a pocket into which a ball has gotten. For example, a condition whose requirement is satisfied when specific symbols form a winning arrangement in a slot game is employed as the predetermined game condition. In addition, the predetermined game condition is not limited to this embodiment. For example, various conditions related to the slot game such as a condition satisfied when a winning arrangement is formed a predetermined number of times or more or a condition satisfied when a specific winning arrangement is formed may be used as the predetermined game condition. Alternatively, when a game other than a slot game is executed by the station unit 2, various conditions related to the game may be employed as the predetermined game condition.

[0026] The center unit 3 includes a center monitor 11 and a roulette game unit RG. The roulette game unit RG includes a roulette ring 12, a ball feeding mechanism 13, and a ball guidepath 14. The roulette ring 12 is arranged such that a front side (a side at which the

station unit 2 is arranged) of the roulette ring 12 is positioned downwardly, a rear side of an opposite side is positioned upwardly, and so the roulette ring 12 is inclined. Further, the roulette ring 12 is arranged below the center monitor 11 so that the rear side of the roulette ring 12, i.e., an upper portion of the inclination is hidden by the center monitor 11. The roulette ring 12 is rotationally driven in a predetermined direction at a predetermined speed by a ring drive mechanism (not illustrated), and then the rotation is stopped at an appropriate timing by a brake unit (not illustrated). Pockets 16 are disposed around the roulette ring 12. Each pocket 16 is associated with a predetermined privilege.

[0027] The ball feeding mechanism 13 is a mechanism for feeding a ball to the ball guidepath 14. In other words, the ball is fed to the ball guidepath 14 by the ball feeding mechanism 13. The ball guidepath 14 is formed to extend along the outer circumference of the roulette ring 12. A guard 14g for limiting a movement of a ball is disposed at an outer circumference side of the ball guidepath 14, i.e., the opposite side of the roulette ring 12. The guard 14g restricts a movement of a ball to prevent the ball from being led astray from the ball guidepath 14. That is, the ball guidepath 14 is formed to restrict a moving range of a ball fed by the ball feeding mechanism 13 to a certain range so that the ball can be guided to the pocket 16 of the roulette ring 12.

[0028] Meanwhile, the center monitor 11 displays an image for making up for the hidden portion of the roulette ring 12. Specifically, as illustrated in Fig. 1, the center monitor 11 display an image corresponding to the hidden portion of the roulette ring 12 such that the image has continuity with the roulette ring 12. With the rotation of the roulette ring 12, an image corresponding to the roulette ring 12 displayed on the center monitor 11

rotates so as to virtually show the rotation of the roulette ring 12. Similarly, when the roulette ring 12 stops, the image corresponding to the roulette ring 12 displayed on the center monitor 11 also stops. The display of the image is realized by simulating an operation of the roulette ring 12, that is, rotation and stop of the roulette ring 12.

[0029] When a roulette game starts, the roulette ring 12 starts rotation. The ball feeding mechanism 13 feeds a ball to the ball guidepath 14. The fed ball travels along the ball guidepath 14. Since the roulette ring 12 is inclined such that the front side is positioned downwardly, the ball guidepath 14 is similarly inclined. Thus, the fed ball travels toward the opposite side of the ball feeding mechanism 13 along the ball guidepath 14, but the ball changes its traveling direction in the middle of the inclination and so travels to return to the ball feeding mechanism 13 side. After this travel is repeated several times, the traveling range of the ball converges to the lowermost position of the ball guidepath 14, i.e., the lowermost position of the roulette ring 12. Then, the ball goes into any one pocket 16 (mainly, the pocket 16 at the lowermost position at an appropriate time) of the roulette ring 12 at an appropriate time. A player is given a predetermined privilege associated with the pocket 16 into which the ball has gone.

[0030] The center unit 3 will be described in further detail with reference to Figs. 2 and 3. Fig. 2 is a schematic enlarged view of the center unit 3. As illustrated in Fig. 2, the center unit 3 includes a center game unit 3a functioning as a first game unit and a base unit 3b. The center game unit 3a and the base unit 3b are units independent of each other. In other words, the center game unit 3a and the base unit 3b can be conveyed or arranged independently of each other in a unit of only the center game unit 3a, only the

base unit 3b, or the like. The center game unit 3a is arranged on the base unit 3b. The center monitor 11 and the roulette game unit RG are provided on the center game unit 3a.

[0031] Fig. 3 is a schematic enlarged view of the base unit 3b. As illustrated in Fig. 3, a base 20 is disposed on the base unit 3b. The base 20 is formed in a triangular form in which three corners of the base 20 are chamfered and so three chamfered portions 20a are formed. Leveling machines 21 are disposed on two of the three chamfered portions 20a. The leveling machine 21 is a machine for adjusting an inclination of the base 20. More specifically, the leveling machine 21 is arranged so as to move the chamfered portion 20a up or down. In other words, the base 20 is configured to be able to move the two chamfered portions 20a up or down based on the position of the remaining one chamfered portion 20a1. Thus, the base 20 is configured to be able to adjust an inclination of the one chamfered portion 20a1 or an inclination of the two sides extending from the one chamfered portion 20a1. The center game unit 3a is arranged such that the lowermost position of the roulette ring 12 corresponds to the one chamfered portion 20a1 (the chamfered portion 20a1 used as the reference for inclination adjustment).

[0032] A roller 22 is provided on the upper side of the base 20. A support table 23 is provided on the roller 22. The support table 23 is a table for supporting the center game unit 3a. In other words, the center game unit 3a is arranged on the support table 23. The support table 23 is configured to be able to rotate on a center C of the support table 23. A rotary drive source 24 for rotationally driving the support table 23 is provided in the base 20. In other words, the center game unit 3a is arranged so as to be rotationally driven by the rotary drive source 24 through the support table 23. The rotary drive source 24 functions as a rotary drive device of the present invention.

[0033] Next, a configuration of a control system of the game machine 1A will be described with reference to Fig. 4. Fig. 4 is a functional block diagram illustrating a schematic configuration of a control system of the game machine 1A. As illustrated in Fig. 4, the game machine 1A includes a station control unit 30 and a center control unit 40. The station control unit 30 is configured as a computer unit that controls the station unit 2. Specifically, the station control unit 30 is configured as a computer unit that includes a microprocessor, and other peripheral devices necessary for an operation thereof such as a main storage device or the like. The station control unit 30 is provided for each station unit 2 as a component of the station unit 2. The center control unit 40 and each station control unit 30 are connected to each other so that transmission and reception of information can be performed therebetween.

[0034] Further, an external storage device 31 is connected to the station control unit 30. As the external storage device 31, for example, there are used storage media that retain stored information even after power is turned off such as a magnetic storage medium including a hard disk or the like, an optical storage medium including a DVD-ROM or the like, or a non-volatile semiconductor memory including an EEPROM or the like.

[0035] The external storage device 31 stores a game program 32 and game data 33. The game program 32 refers to a program necessary for the station unit 2 to execute the slot game. The game data 33 refers to a variety of data used when the game program 32 is executed. The game program 32 is appropriately read and executed by the station control unit 30. The game data 33 is also appropriately read and referred to by the station control unit 30. The game data 33 includes a variety of data such as reel data, sound effect data, and dividend data, but an illustration thereof is omitted.

[0036] As the game program 32 is executed, the station control unit 30 executes a process necessary for the station unit 2 to provide a slot game. For example, the station control unit 30 executes a process of changing a display of symbols, a process of generating a random number with a predetermined number of digits, a process for a lottery of symbols to be displayed after a change using the random number, and a process for determining whether or not a combination of symbols after a change has formed a winning arrangement. In addition, a random number may be generated by a physical device into which an electronic circuit is incorporated.

[0037] Further, the operation device 9 and the station monitor 6 is connected to the station control unit 30. The operation device 9 outputs a signal corresponding to a player's operation to the station control unit 30. The station monitor 6 displays an image corresponding to an image signal output from the station control unit 30. The station control unit 30 executes a game by a predetermined procedure according to the game program 32 with reference to the output signal of the operation device 9. Because of these, the station control unit 30 causes a game screen corresponding to a status of a slot game to be displayed on the station monitor 6.

[0038] Further, a coin insertion device 34 and a dispensing device 35 which respectively function as an input device or an output device necessary to execute a slot game are connected to the station control unit 30. The coin insertion device 34 accepts an inserted coin as counter value for playing a game through the coin insertion slot 8. Then, the coin insertion device 34 outputs a signal corresponding to an amount of inserted coins to the station control unit 30.

[0039] The dispensing device 35 pays a coin to a player as a dividend of a game according to an instruction from the station control unit 30. A coin is paid through the coin-payout opening 10. In addition, a counter value to be received and a dividend for a player are not limited to a coin. For example, an alternative currency such as a metal, a token, or the like may be used. Alternatively, an accounting method capable of exchanging a currency value or a game value through an exchange of an electronic currency or other electronic information may be used. In this case, an information communication device for mutually exchanging electronic information, a storage medium for storing exchanged information, and the like may be used instead of the coin insertion slot 8 and the coin-payout opening 10.

[0040] Meanwhile, the center control unit 40 is configured as a computer unit that controls the center unit 3. Specifically, the center control unit 40 is configured as a computer unit that includes a microprocessor, and other peripheral devices necessary for an operation thereof such as a main storage device or the like. The roulette game unit RG, the leveling machine 21, the rotary drive source 24, and the inclination sensor 45 are connected to the center control unit 40. The inclination sensor 45 is a sensor for detecting an inclination of the center game unit 3a. The inclination sensor 45 is disposed in the base 20. More specifically, the inclination sensor 45 is disposed near the chamfered portion 20a1 so as to correspond to the chamfered portion 20a1 used as the reference of inclination adjustment. In other words, the inclination sensor 45 detects an inclination of the center game unit 3a, that is, an inclination of the roulette ring 12 based on an inclination of the base 20. In addition, two or more inclination sensors 45 may be

disposed corresponding to the chamfered portions 20a so as to be able to detect inclinations of the chamfered portions 20a, respectively.

[0041] Further, an external storage device 41 is connected to the center control unit 40. As the external storage device 41, for example, there is used storage media that retain stored information even after power is turned off such as a magnetic storage medium including a hard disk or the like, an optical storage medium including a DVD-ROM or the like, a non-volatile semiconductor memory including an EEPROM or the like.

[0042] The external storage device 41 stores a center unit program 42 and a center unit data 43. The center unit program 42 refers to a program necessary for the center unit 3 to execute the roulette game. The center unit data 43 refers to a variety of data used when the center unit program 42 is executed. As an example of a variety of data, the center unit data 43 includes a station management data 43a as management information. The station management data 43a is data for managing the position of each station unit 2 or the like. The details of the station management data 43a will be described later.

[0043] The center unit program 42 is appropriately read and executed by the center control unit 40. The center unit data 43 is appropriately read and referred to by the center control unit 40. In addition, the center unit data 43 includes a variety of data such as sound effect data, dividend data in addition to the station management data 43a, but an illustration thereof is omitted.

[0044] As the center unit program 42 is executed, the center control unit 40 executes various processes necessary for the center unit 3 to provide the roulette game. For example, the center control unit 40 executes a process for controlling the roulette game unit RG. This process includes control of various mechanisms included in the roulette

game unit RG such as the ball feeding mechanism 13, the ring drive mechanism (not illustrated), and the brake unit (not illustrated). The process executed by the center control unit 40 includes a process for simulating rotation of the roulette ring 12 and a process for causing an image corresponding to the roulette ring 12 to be displayed on the center monitor 11 based on the processing result of the simulation process. Besides, for example, the process executed by the center control unit includes a process for controlling an operation of the leveling machine 21 based on an output result of the inclination sensor, a process for managing the layout of the station units 2, and a process for controlling an operation of the rotary drive source 24 such that a direction of the center game unit 3a is changed. The process executed by the center control unit 40 will be described later.

[0045] Next, a layout management of the station units 2 will be described with reference to Fig. 5. Fig. 5 is a schematic plane view when the game machine 1A is viewed from the top. In Fig. 5, a dotted line represents the center unit 3. As illustrated in Fig. 5, the outer unit 4 is interposed between the station units 2 and the center unit 3. A predetermined interval H is left between the outer unit 4 and the center unit 3. In other words, the outer unit 4 functions as a barrier to form an interval between the center unit 3 and the station unit 2.

[0046] A use direction used to provide a roulette game is limited to a direction in which the roulette ring 12 is inclined. In other words, the use direction of the center unit 3 refers to a direction in which the lowermost portion of the roulette ring 12 is positioned. More specifically, the use direction S refers to a direction from the center C of the support table 23 to a lowermost position P of the roulette ring 12, that is, from the

rotational center C of the center game unit 3a to the lowermost position P of the roulette ring 12. In other words, one of radial directions extending from the rotational center C toward the outer circumference of the support table 23 is used as the use direction S. Here, the center game unit 3a is rotatable. The use direction S rotates with the rotation of the center game unit 3a. Thus, the center unit 3 can provide a roulette game in all directions around the center unit 3. In other words, the use direction S in which a roulette game is provided to each station unit 2, that is, each use direction S corresponding to each station unit 2 is a roulette game provision direction (a first provision direction).

[0047] Meanwhile, the station units 2 are arranged on the circumference around the outer unit 4 in order from a lower station unit 2a to a right station unit 2h in a right-hand turning (clockwise) direction so that the station units 2 can be positioned in the roulette game provision direction. The station units are arranged in the form of a windmill with respect to the center unit 3. More specifically, the following layout is made. First, a slot game is provided through the station monitor 6. Thus, a side at which the station monitor 6 is arranged is the front side. A player is positioned in the front and uses the station unit 2. For this reason, a direction extending from the station monitor 6 toward the player side corresponds to a slot game provision direction UD (a second provision direction). And, the station units 2 are arranged so as to cause the second provision direction UD to intersect with the first provision direction S. In other words, the center unit 3 is not arranged at a place where the sight line of the player who is playing the station unit 2 extends. When a roulette game is provided, the center game unit 3a

rotates to thereby position the use direction S to face the side of the player. In other words, a roulette game is provided from the side of the player.

[0048] The center unit 3 and the station units 2 are configured as units independently of each other. In other words, each of the station units 2 can be individually detached from or attached to the center unit 3 in one unit. Thus, an arbitrary number of station units 2 may be arranged at an arbitrary position around the outer unit 4. For this reason, a layout setting operation is executed at an appropriate time, for example, when the game machine 1A is installed or when the position or the like of the station unit 2 is changed. For example, a layout setting method of setting the position (for example, rotational angle) of each station unit 2 while rotating the center game unit 3a through the support table 23 is applied to implement an installation management operation.

[0049] The layout setting method will be described with reference to Figs. 5 to 7. Fig. 5 illustrates an example in which the use direction S is positioned downward in Fig. 5 (the use direction S corresponding to the right station unit 2h). For example, when this position is set as an initial position of the use direction S, in the layout setting method, the positions of the station units 2 are set during rotation of the center game unit 3a so as to rotate the use direction S once time in the right-hand turning direction L. Specifically, with the rotation of the center game unit 3a, the direction of the use direction S changes in order from the lower station unit 2a to the right station unit 2h. The position (which is represented by, for example, a central angle based on the initial position) of the station unit 2 is set during this rotation.

[0050] Fig. 6 is a flowchart illustrating the flow of the layout setting method. For example, the layout setting method of the example of Fig. 6 is executed by an

administrator of a facility where the game machine 1A is installed. As illustrated in Fig. 6, in the layout setting method of the example of Fig. 6, the center unit 3 is first installed (step S1). Next, the station units 2 are arranged around the center unit 3 (step S2). Subsequently, rotation of the center unit 3a starts (step S3). Then, the rotation of the center unit 3a stops at the position where the position of the station unit 2 corresponds to the use direction S (step S4). Then, attribute information of the station unit 2 positioned in the use direction S is input (step S5). For example, ID information unique to each station unit 2 is used as the attribute information. The ID information is used to identify each station unit 2. In other words, for example, the ID information of the station unit 2 positioned in the use direction S is input in step S5. For example, this input is executed by an executor of the layout setting method. For example, an input device (not illustrated) such as a keyboard is used for this input.

[0051] As the attribute information is input, the center control unit 40 acquires positional information corresponding to the current stop position (step S6). More specifically, a central angle between the initial position and the current stop position is calculated, and the central angle is acquired as the positional information. Subsequently, the station management data 43a is generated based on the attribute information input in step S5 (step S7). For example, this generation is achieved through a predetermined process executed by the center control unit 40. As an example, the predetermined process is executed with the input of the attribute information. The generated station management data 43a is stored in the external storage device 41. The station management data 43a is used for a variety of processes. In other words, with the input (step S5) of the attribute, the position and the attribute of the station unit 2 used for a variety of processes are set.

Next, it is determined whether or not the current stop position corresponds to the rotation start position (initial position) (step S8). For example, this determination may be executed each time the center control unit 40 generates the station management data 43a or may be executed by the executor of the layout setting method. When the determination result is positive, that is, when the current stop position corresponds to the rotation start position, the current layout setting ends.

[0052] However, when the current stop position does not correspond to the rotation start position, rotation of the center game unit 3a starts again (step S3). In other words, when the determination result of step S8 is negative, the process returns to step S3, the process of step S3 and the subsequent processes are executed again. In the layout setting method, the layout of the station units 2 is set during the rotation such that the use direction S faces the direction of the station unit 2 at least once time like this.

[0053] The layout setting result of the station units 2 can be checked through a layout check screen. Fig. 7 is a diagram illustrating an example of a layout check screen 50. As illustrated in Fig. 7, the layout check screen 50 includes a center image 51 and arrangement lines 52. The center image 51 is an image corresponding to the center unit 3. In other words, the center image 51 represents the position at which the center unit 3 is arranged. Each arrangement line 52 corresponds to each station unit 2. In other words, each arrangement line 52 represents the position of each station unit 2 with respect to the center unit 3. Specifically, the arrangement lines 52 radially extend centering on the center image 51 so as to correspond to the positions at which the station units 2 are arranged. Thus, an interval between the arrangement lines 52 corresponds to the central angle at which each station unit 2 is positioned with respect to the center unit

3. The ID information of the station unit 2 corresponding to the arrangement line 52 is displayed on the leading end (the opposite side of the center image 51) of the corresponding arrangement line 52. The ID information represents a correspondence relation between each arrangement line 52 and each station unit 2. For example, the layout check screen 50 is displayed on the center monitor 11 according to an operation of an administrator having a layout setting right. The station management data 43a is used to display the layout check screen 50.

[0054] Next, the details of the station management data 43a will be described with reference to Fig. 8. Fig. 8 is a diagram illustrating an example of content of the station management data 43a. As illustrated in Fig. 8, the station management data 43a includes information of acquisition No., information of position, and information of station ID as identification information. The station management data 43a is configured as a set of records described such that the above information is associated with one another.

[0055] The information of station ID refers to information for identifying each station unit 2. For example, the above-described ID information is used as the information of station ID. For example, a number with a predetermined number of digits is used as the ID information. In other words, for example, a number with a predetermined number of digits which is unique to each station unit 2 is described as the information of station ID.

[0056] The information of position refers to information representing the position of each station unit 2 with respect to the center unit 3. For example, information of the central angle represented based on the initial position of the use direction S is used as the information of position. Numbers in which the initial position is set "0" may be used as

the information of the central angle. In other words, for example, a number representing the central angle from the initial position is described as the information of position.

[0057] The information of acquisition No. refers to information representing an order in which layout setting is made in the layout setting method. For example, the station ID of the station unit 2 whose position is first set in the layout setting method may be associated with "1". In other words, for example, a number, such as 1, representing an order in which the information of position corresponding to each station ID is set is described as the information of acquisition No.

[0058] Next, a center unit moving process routine executed by the center control unit 40 will be described. As described above, the center unit 3 provides a roulette game through the roulette ring 12. The roulette ring 12 is arranged such that the use direction S is inclined. For this reason, a direction in which a roulette game is provided is limited. In other words, when a roulette game is provided, the position of the station unit 2 which is a provision destination of a roulette game preferably corresponds to the use direction S. The roulette game is provided to the player of the station unit 2 that satisfies a predetermined game condition. In other words, a provision destination of a roulette game changes within a range in which the station units 2 are arranged. The center unit moving process routine refers to a process for causing the use direction S to correspond to the position of the station unit 2 which is a provision destination of a roulette game.

[0059] Fig. 9 is a diagram illustrating an example of a flowchart of a center unit moving process routine executed by the center control unit 40. For example, the center control unit 40 executes the routine of Fig. 9 each time each station unit 2 satisfies a predetermined game condition. When the multiple station units 2 satisfy a

predetermined game condition, the routine of Fig. 9 is executed in an order in which the predetermined game condition is satisfied. In addition, the center control unit 40 may execute a well-known process necessary to execute a roulette game in addition to the center unit moving process routine, but a detailed description thereof will not be made.

[0060] When the routine of Fig. 9 starts, in step S11, the center control unit 40 first determines a provision destination of a roulette game, that is, an attribute of the station unit 2 that has satisfied a predetermined game condition. For example, this determination is achieved such that the station control unit 30 of the station unit 2 that has satisfied a predetermined game condition outputs a predetermined signal (including attribute information) to the center control unit 40. For example, the station ID is used as the attribute. In other words, the center control unit 40 determines the attribute (station ID) by acquiring the station ID of the station unit 2 that has satisfied a predetermined game condition based on the signal from the station control unit 30.

[0061] Next, in step S12, the center control unit 40 acquires the station management data 43a. Subsequently, in step S13, the center control unit 40 determines the position of the station unit 2 to which a roulette game is to be provided based on the determination result of step S11 and the station management data 43a acquired in step S12. This determination is achieved by acquiring the information of position included in the station management data 43a corresponding to the station ID acquired as the determination result of step S11.

[0062] Subsequently, in step S14, the center control unit 40 rotates the center game unit 3a based on the determination result of step S13 so that the use direction S faces the direction of the station unit 2 to which the roulette game is provided. More specifically,

the center control unit 40 controls an operation of the rotary drive source 24 such that the center game unit 3a rotates until the position of the station unit 2 of the provision destination corresponds to the use direction S. When this process ends, the center control unit 40 ends the current routine. Accordingly, the center game unit 3a rotates according to the position of the corresponding station unit 2 that has satisfied a predetermined game condition so that the use direction S faces the position of the station unit 2.

[0063] In addition, when the plurality of inclination sensors 45 are disposed so as to be able to detect inclinations of chamfered portions 20a, respectively, the routine of Fig. 9 may include a process for adjusting an inclination (Fig. 1 to Fig. 5 are referred to). Specifically, in a state in which the use direction S faces the position of the station unit 2 that has satisfied a predetermined game condition, the center control unit 40 may determine an inclined state of the roulette ring 12 based on the detection result of the inclination sensor 45 and may control an operation of the leveling machine 21 so that the roulette ring 12 forms a predetermined inclination. In this case, an inclination is further adjusted in a state in which the position of the station unit 2 that has satisfied a predetermined game condition corresponds to the use direction S. Thus, fairness of a roulette game is guaranteed through the use direction S is positioned in any direction.

[0064] As described above, according to the game machine 1A of this embodiment, the center unit 3 and the station unit 2 are configured independently of each other and arranged so as to form the predetermined interval H therebetween. Thus, influence of vibration or the like generated in the station unit 2 can be suppressed. In other words,

influence of wrongdoing conducted, for example, using vibration on the center unit 3 can be suppressed.

[0065] Further, the roulette game is provided when each station unit 2 satisfies a predetermined game condition. In other words, the roulette game serves as a sub game of a main game provided by the station unit 2. The sub game needs to be positioned to be viewable from the player of the main game. As the sub game, preferable is a game which is consistent regardless of the player's position, that is, a game in which a provision direction is not restricted. Thus, the center unit and the station unit of the conventional art have restrictions to a mutual positional relation and the type or the form of sub game for providing the sub game and the main game.

[0066] According to the game machine 1A of this embodiment, the position of each station unit 2 is set during single rotation of the center unit 3. In other words, each station unit 2 does not need to be arranged at the position which has been decided in advance. Accordingly, the game machine 1A, that is, the center unit 3 and the station units 2 can be easily arranged. Further, there is little restriction to the positional relation between the center unit 3 and each station unit 2. Accordingly, layout tolerance of each station unit 2 can be enhanced. As a result, a degree of freedom in a layout space of the game machine 1A can be enhanced. Further, by changing the layout of the game machine 1A, it is possible to provide a variation to a provision method of the game machine 1A. Furthermore, the position of the use direction S can change so as to correspond to the position of each station unit 2. Thus, a game in which a provision direction is restricted can be provided as a sub game. Thus, the type or the form of sub

game can be freely selected. Accordingly, amusement of the game machine 1A can be improved.

[0067] Furthermore, in the conventional game machine, the main game unit providing the main game and the sub game unit providing the sub game are arranged so that the first provision direction corresponds to the second provision direction. For example, the main game units are arranged such that the back sides thereof face the sub game unit side. That is, each station unit is arranged such that the sub game unit is positioned on an imaginarily extended line of the sight line of the player. In this case, the sub game unit needs to be configured so as to provide the sub game at the position higher than the main game unit. This is because a phenomenon that the sub game is not shown may occur when the sub game unit is positioned to be lower than the main game unit, since the two units have the same provision direction. For this reason, the sub game unit tends to be higher in height than the main game unit. Further, the player needs to take a posture casting his/her eyes up and so is likely to get tired easily.

[0068] According to the game machine 1A of this embodiment, the first provision direction S does not match the second provision direction UD. In other words, the center unit 3 is not positioned on an imaginarily extended line of the second provision direction UD. Then, the center unit 3 provides the roulette game from the side of the player. For this reason, the height of the roulette ring 12 can be lower than the height of the station unit 2. Thus, since the height of the center unit 3 can be suppressed, the height of the whole game machine 1A can be suppressed. Further, unlike the conventional layout, the station monitor 6 or the like is not positioned at the side. For this reason, the roulette game can be provided so as to be more easily viewable. Thus,

amusement of a game can be improved. Further, a posture facing the side tends to be smaller in the player's fatigue than a posture casting his/her eyes up. Thus, the player's fatigue can be suppressed.

[0069] In the above embodiment, the center control unit 40 functions as a positional information acquiring device and a management information generating device by executing step S6 and step S7 of the routine of Fig. 6, respectively, and functions as a position determining device and a rotation control device by executing the routine of Fig. 9. Further, the center control unit 40 functions as an attribute information acquiring device by acquiring the attribute information through the routine of Fig. 6.

[0070] In the above embodiment, the positional information is acquired with the input of the attribute information. However, the acquisition of the positional information is not limited to this embodiment. For example, the positional information of each station unit 2 may be acquired based on a capturing result of a camera that can capture an area around the center unit 3. Besides a camera, a detector capable of omni-directionally detecting an area around the center unit 3 may be used for position detection. In other words, a detecting device for detecting the position of each station unit 2 may be provided as a position detecting device.

[0071] Further, as the layout setting method, there may be applied a method using the photo sensor. As an example, the layout setting method like this is achieved by an operation which uses the plurality of photo sensors and a light-shielding device. Specifically, for example, the photo sensors (for example, 32 pieces) are provided on the top face side (the side of the support table 23) of the base 20 of base unit 3b. Further, for example, each photo sensor is arranged in the vicinity of the circumference of support table

23 along the circumferential direction at regular intervals so as to face the support table 23. In contrast, the light-shielding device is provided on the support table 23 so as to be able to shield each photo sensor during the rotation of the center game unit 3a. According to an arrangement like this, the light-shielding device shields each photo sensor in series during the rotation of the center game unit 3a. The operator stands in front of each station unit 2 and stops the rotation of the center game unit 3a when the center game unit 3a rotates and thereby the center game unit 3a positions at the front. For example, this stopping is achieved by a button which is provided on each station unit 2. And, with stopping of the rotation of the center game unit 3a, the position of the photo sensor which is shielded by the light-shielding device at last is stored as the position of the station unit 2. Further, for example, each station unit 2 is determined by the button which is used for stopping. In this way, the position of each station unit 2 is set by the repetition of the rotation of the center game unit 3a and the stopping in front of each station unit 2. As an example, the layout setting method like this may be applied.

Second Embodiment

[0072] Next, a game machine 1B according to a second embodiment of the present invention will be described. In the game machine 1B according to the second embodiment, there is executed a layout setting operation different from the game machine 1A according to the first embodiment. In order to execute this layout setting operation, the game machine 1B according to the second embodiment has a configuration different from the game machine 1A according to the first embodiment. In the following, the

same components as in the first embodiment are denoted by the same reference numerals, and thus a description thereof will not be made.

[0073] Fig. 10 is a functional block diagram illustrating a schematic configuration of a control system of the game machine 1B. As illustrated in Fig. 10, an infrared transmitter 60 functioning as an attribute information transmitting device is connected to the station control unit 30 of the game machine 1B according to the second embodiment. The infrared transmitter 60 is a device that outputs an infrared ray in a predetermined direction. For example, the infrared transmitter 60 is disposed on the back side of the station unit 2. Further, for example, the infrared transmitter 60 is arranged so as to output an infrared ray in a direction perpendicular to a display surface of the station monitor 6. The infrared transmitter 60 is controlled by the station control unit 30. The station control unit 30 controls an output of the infrared transmitter 60 so that the attribute information is included in the infrared ray. For example, blinking may be used to include the attribute information in the infrared ray output from the infrared transmitter 60.

[0074] Meanwhile, an infrared receiver 61 functioning as an attribute information receiving device is connected to the center control unit 40. The infrared receiver 61 is a device for receiving the infrared ray output from the infrared transmitter 60. For example, the infrared receiver 61 is disposed on the side surface of the center unit 3 so as to face the direction of the infrared transmitter 60. In order to receive the infrared ray output from the infrared transmitter 60, the infrared receiver 61 is arranged so as to correspond to the height at which the infrared transmitter 60 is arranged (or an output

angle of the infrared transmitter 60). A reception result of the infrared receiver 61 received is output to the center control unit 40.

[0075] Next, a layout setting process routine executed by the center control unit 40 will be described. Fig. 11 is a diagram illustrating an example of a flowchart of the layout setting process routine executed by the center control unit 40. For example, the center control unit 40 executes the routine of Fig. 11 each time a predetermined layout setting operation is executed.

[0076] When the routine of Fig. 11 starts, in step S21, the center control unit 40 first rotates the center game unit 3a one revolution. More specifically, the center control unit 40 controls an operation of the rotary drive source 24 such that the center game unit 3a rotates one revolution. Next, in step S22, the center control unit 40 acquires the attribute information of each station unit 2. For example, this acquisition is executed in the following way. First, the center control unit 40 receives the reception result of the infrared receiver 61 while rotation is being made one revolution in step S21. Then, the center control unit 40 determines the number of received infrared rays, a reception position (central angle), and the attribute information included in each infrared ray, based on the acquired reception result. As a result, the number, the positions, and the attributes of the station units 2 arranged around the center unit 3 are acquired. For example, the reception position may be calculated based on a reception time and a rotation speed. Further, the position or the attribute information may be determined and then stored each time the infrared ray is received during rotation.

[0077] Subsequently, in step S23, the center control unit 40 generates the station management data 43a based on the acquisition result of step S22, and then ends the

current routine. As a result, the station management data 43a including information about the number, the positions, the attributes of the station units 2 is generated. The station management data 43a is used for a variety of processes using the positions and the attributes of the station units 2. In other words, the number, the positions, the attributes of the station units 2 are automatically set through the routine of Fig. 11. In addition, in the example of Fig. 11, in step S21, the center game unit 3a rotates one revolution. However, the layout setting process routine is not limited to this embodiment. For example, rotation of the center game unit 3a may stop each time the infrared receiver 61 receives the infrared ray. In this case, the infrared ray transmitted from the infrared transmitter 60 can be received with a high degree of accuracy. In other words, the number, the positions, the attributes of the station units 2 can be set with a high degree of accuracy.

[0078] According to the game machine 1B of this embodiment, information such as the position of each station unit 2 with respect to the center unit 3 is automatically set. For this reason, time and effort or the like to set the position of each station unit 2 or the like are reduced. Accordingly, setting of the position or the like can be easily achieved.

[0079] In the above embodiment, the center control unit 40 functions as a positional information acquiring device, an attribute information acquiring device, and a management information generating device by executing the routine of Fig. 11.

[0080] In the second embodiment, the infrared transmitter 60 is used as the attribute information transmitting device, and the infrared receiver 61 is used as the attribute information receiving device. However, the attribute information transmitting device and the attribute information receiving device are not limited to this embodiment. For

example, a bar code including attribute information may be used as the attribute information transmitting device, and a camera capable of capturing the bar code may be used as the attribute information receiving device. The bar code is a sort of code which is created in conformity to a predetermined standard. The bar code functions as a sort of signal by conforming to a predetermined standard. Even in this case, the position of each station unit 2 or the like can be automatically set.

[0081] The present invention is not limited to the first embodiment and the second embodiment and can be embodied in an appropriate form. In the above embodiments, the station ID, that is, the identification information for identifying each station unit 2 is used as an example of the attribute information. However, the attribute information is not limited to this embodiment. For example, as the attribute information, there may be used information such as information representing the type of a game provided by each station unit 2, version information of a program and data used to provide a game, or the like. In this case, it is possible to provide a game machine that can easily acquire data for managing the type, the version, or the like of a game provided by each station unit 2.

[0082] In the above embodiments, the slot game functions as the main game, and the roulette game functions as the sub game. However, games provided by the center unit 3 and the station unit 2 are not limited to this embodiment. For example, contrary to the above embodiment, the center unit 3 may provide the main game, and the station unit 2 may provide the sub game. Furthermore, the sub game is not limited to the roulette game. For example, as the sub game, there may be provided a lottery game such as a pinball game, slot game, or the like. Much the same is true on the main game.

[0083] In the above embodiments, each station unit 2 is arranged such that the second provision direction UD intersects with the first provision direction. A variety of embodiments may be employed as a embodiment in which the second provision direction UD intersects with the first provision direction. For example, Fig. 12 is a diagram illustrating the layout of the station units 2 according to a first modified embodiment. As illustrated in Fig. 12, each station unit 2 may be arranged such that the second provision direction UD faces the first provision direction S, that is, such that the front side of the station unit 2 is positioned at the center unit 3 side. In this case, the center unit 3 is arranged so as to be positioned behind the player. The behind the player tends to less block the sight line rather than the side of the player. Thus, in this case, the height of the center unit 3 can be further decreased, and it is possible to provide the roulette game so as to be more easily viewable.

[0084] Fig. 13 is a diagram illustrating the layout of the station units 2 according to a second modified embodiment. As illustrated in Fig. 13, station units 2 may include a layout group G. The layout group G includes the station units 2 whose second provision direction UD faces the same direction. In the example of Fig. 13, 4 layout groups G each of which includes 3 station units 2 are configured by 12 station units 2. The layout groups G are arranged around the center unit 3 such that each layout group G forms one side of a rectangle. Consequently, the second provision directions UD of the two station units 2 included in each layout group G are positioned in a direction intersecting with the first provision direction S. For this reason, the game of the center unit 3 can be checked through a space between the station units. Thus, in this case, the height of the center unit 3 can be suppressed. Further, in this case, the station units 2 may be grouped using

the second provision direction UD. In this case, a game of a group unit (for example, a group competition type) can be provided in an aspect in which each group is physically graspable. Accordingly, amusement of a game can be improved. For example, the station units 2 may be arranged such that each second provision direction UD intersects with the first provision direction S (corresponds to a circumferential direction of the center unit 3) in addition to the embodiments.

Claims

What is claimed is:

1. A game machine comprising:
 - a first game unit that provides a first game in a predetermined use direction;
 - at least one second game unit that is arranged around the first game unit and provides a second game related to the first game;
 - a rotary drive device that rotates the first game unit so that the predetermined use direction faces a direction of the second game unit at least once;
 - a positional information acquiring device that acquires positional information for specifying a position of the second game unit during rotation of the first game unit;
 - a position determining device that determines a position of the second game unit based on the positional information acquired by the positional information acquiring device; and
 - a rotation control device that controls the rotary drive device based on a determination result of the position determining device such that the rotary drive device rotates the first game unit and the predetermined use direction faces the direction of the second game unit when the first game unit provides the first game.

2. The game machine according to claim 1, further comprising:
 - an attribute information acquiring device that acquires attribute information of the second game unit; and
 - a management information generating device that generates management

information in which the positional information is associated with the attribute information based on acquisition results of the attribute information acquiring device and the positional information acquiring device.

3. The game machine according to claim 2,
wherein two or more second game units are arranged around the first game unit as the at least one second game unit,

the attribute information acquiring device acquires attribute information of each second game unit for each of positions of the second game units during rotation of the first game unit, and

the management information generating device generates the management information such that the attribute information of each second game unit is associated with positional information corresponding to a position at which each attribute information is acquired.

4. The game machine according to claim 3,
wherein the attribute information includes identification information for identifying each of the second game units, and

the management information generating device generates the management information such that the identification information of each second game unit is associated with the positional information.

5. The game machine according to any one of claims 2 to 4, further comprising:
an attribute information transmitting device that is disposed in the second game unit and transmits a predetermined signal including the attribute information; and
an attribute information receiving device that is disposed in the first game unit and receives the predetermined signal transmitted from the attribute information transmitting device,

wherein the attribute information acquiring device acquires the attribute information by determining the attribute information included in the predetermined signal based on a reception result of the attribute information receiving device.

6. The game machine according to claim 5,
wherein an infrared transmitter that transmits an infrared ray so as to include the attribute information as the predetermined signal is used as the attribute information transmitting device, and

an infrared receiver that receives the infrared ray is used as the attribute information receiving device.

7. The game machine according to claim 5,
wherein the attribute information transmitting device is of a bar code that uses a code, including the attribute information by conforming to a predetermined standard, as the predetermined signal, and

the attribute information receiving device is of a camera that receives information of the bar code by capturing the bar code.

8. The game machine according to any one of claims 5 to 7,
wherein the positional information acquiring device determines a position at which the predetermined signal is received based on a reception result of the attribute information receiving device, and acquires information corresponding to the position as the positional information.
9. The game machine according to any one of claims 1 to 7, further comprising a position detecting device that detects a position of the second game unit,
wherein the positional information acquiring device acquires the positional information based on a detection result of the position detecting device.
10. The game machine according to any one of claims 1 to 9,
wherein the second game relates to the first game in a manner that the second game functions as a main game providing an opportunity to play the first game and the first game functions as a sub game on the main game.
11. A control method of controlling a computer incorporated into a game machine comprising: a first game unit that provides a first game in a predetermined use direction; at least one second game unit that is arranged around the first game unit and provides a second game related to the first game; a rotary drive device that rotates the first game unit so that the predetermined use direction faces a direction of the second game unit at least once, and wherein the control method of controlling the computer comprises the steps:
a positional information acquiring step that acquires positional information for

specifying a position of the second game unit during rotation of the first game unit;

a position determining step that determines a position of the second game unit based on the positional information acquired by the positional information acquiring step; and

a rotation control step that controls the rotary drive device based on a determination result of the position determining step such that the rotary drive device rotates the first game unit and the predetermined use direction faces the direction of the second game unit when the first game unit provides the first game.

12. A computer program for a game machine being configured to cause a computer, which is incorporated into a game machine comprising: a first game unit that provides a first game in a predetermined use direction; at least one second game unit that is arranged around the first game unit and provides a second game related to the first game; a rotary drive device that rotates the first game unit so that the predetermined use direction faces a direction of the second game unit at least once, to function as:

a positional information acquiring device that acquires positional information for specifying a position of the second game unit during rotation of the first game unit;

a position determining device that determines a position of the second game unit based on the positional information acquired by the positional information acquiring device; and

a rotation control device that controls the rotary drive device based on a determination result of the position determining device such that the rotary drive device rotates the first game unit and the predetermined use direction faces the direction of the

second game unit when the first game unit provides the first game.

13. A layout setting method applied to a game machine comprising a first game unit that provides a first game in a predetermined use direction, at least one second game unit that is arranged around the first game unit and provides a second game related to the first game, and a rotary drive device that rotates the first game unit so that the predetermined use direction faces a direction of the second game unit at least once, wherein the layout setting method comprises the steps:

a step that rotates the first game unit through the rotary drive device; and

a position setting step that sets a position at which the predetermined use direction faces the second game unit during rotation of the first game unit as a position of the second game unit.

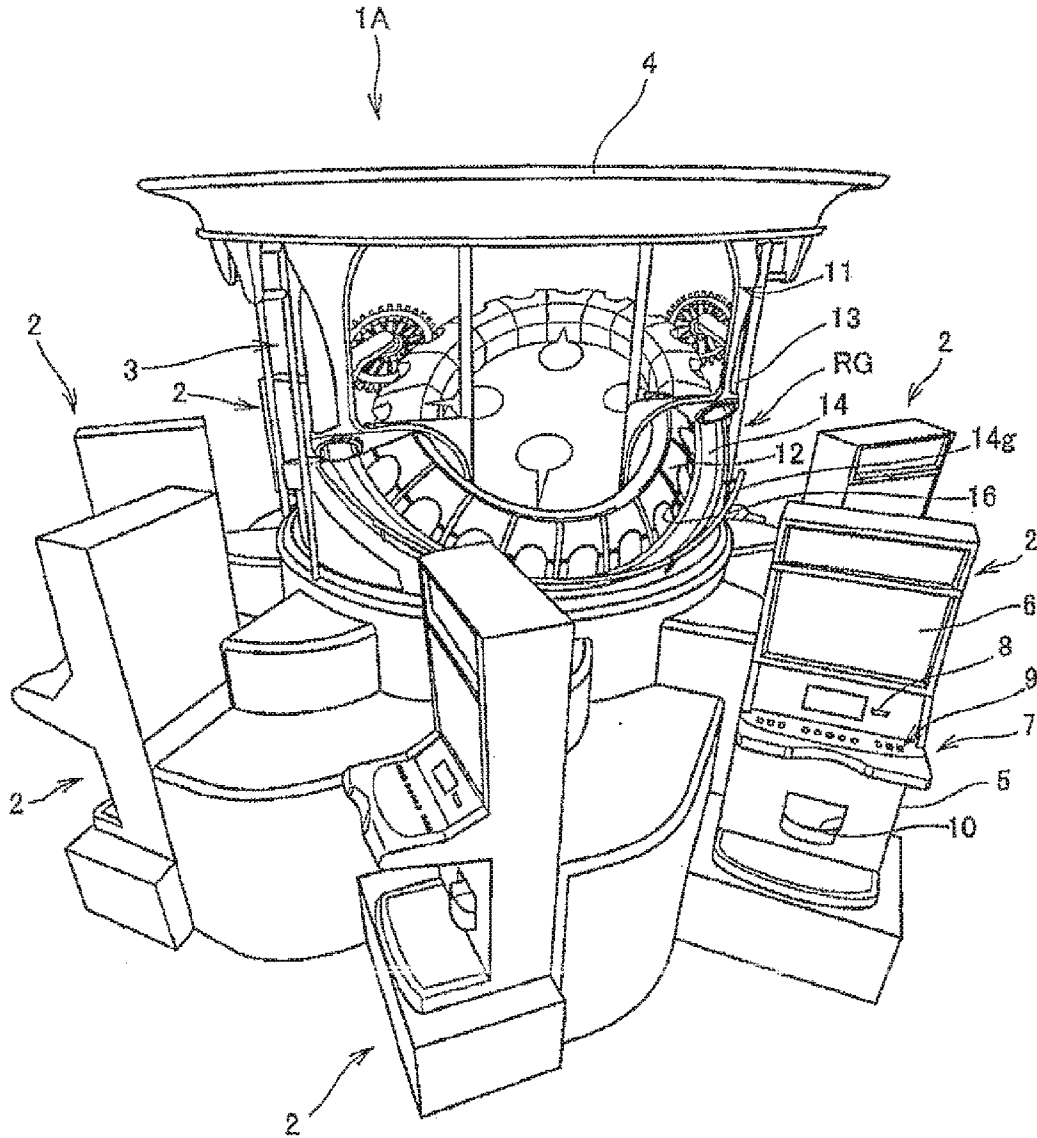

Fig. 1

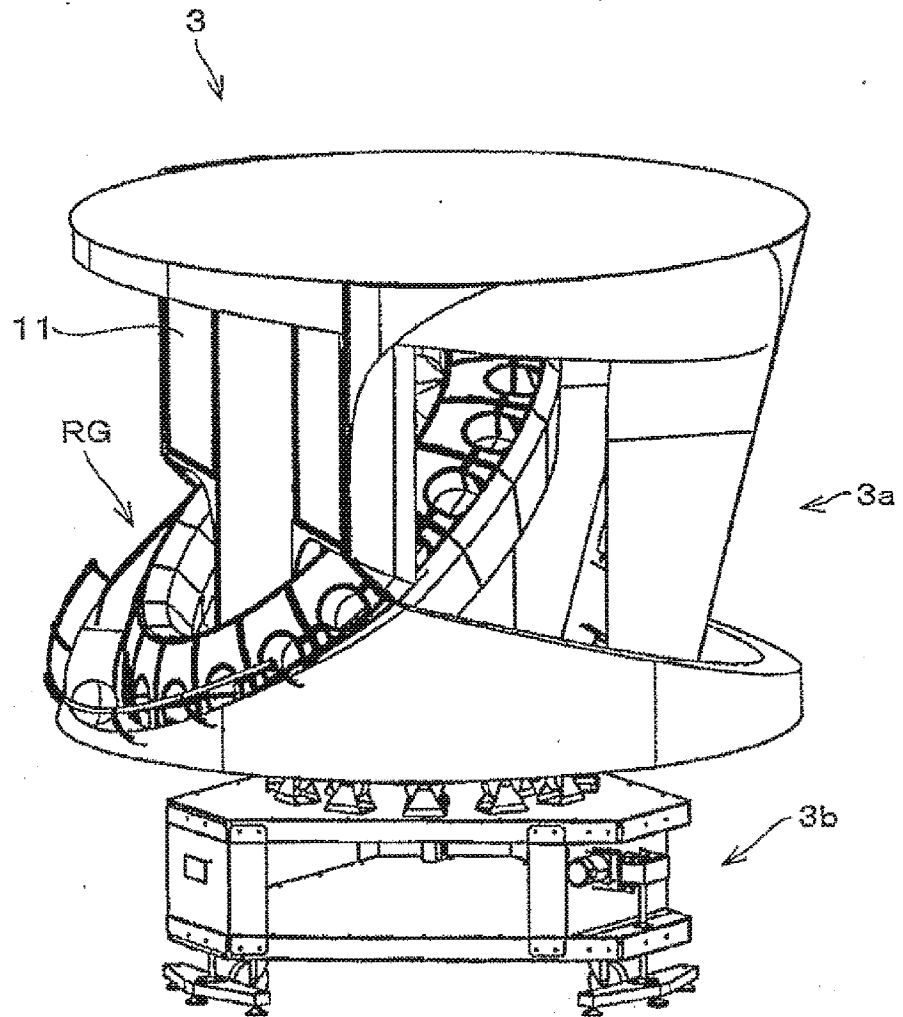

Fig. 2

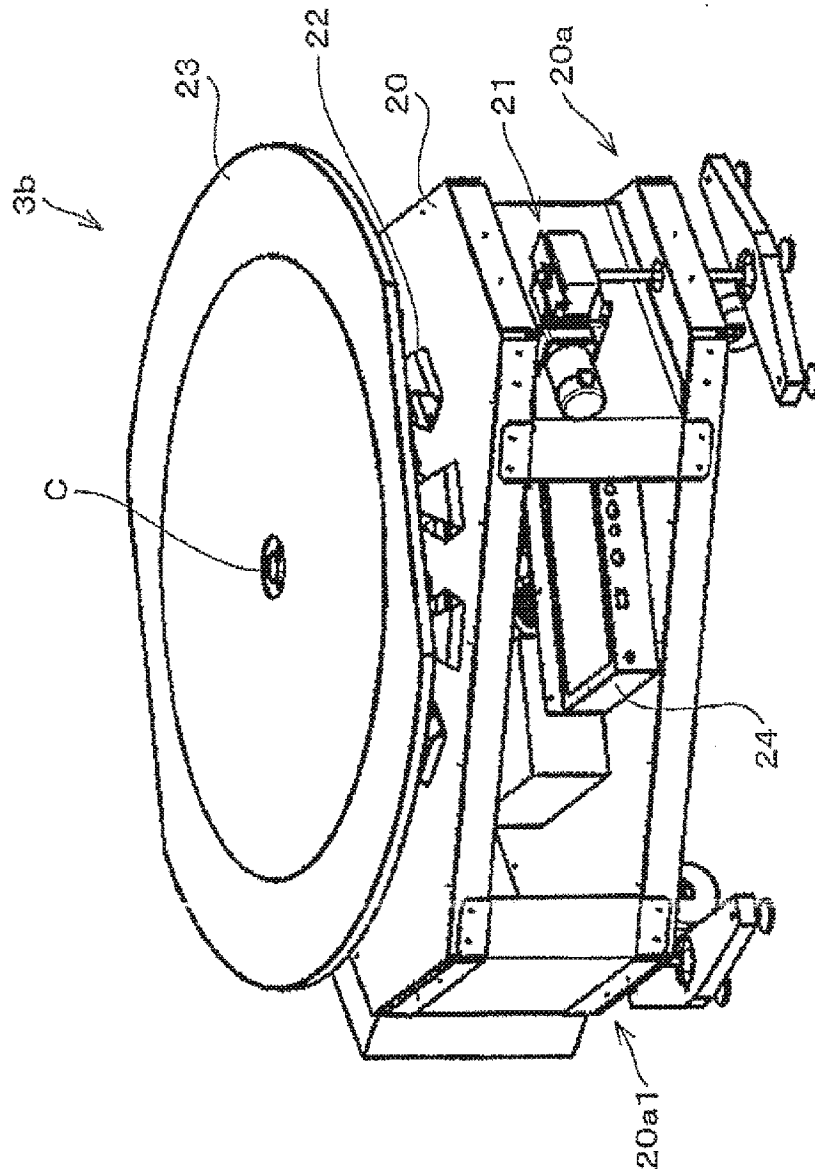

Fig. 3

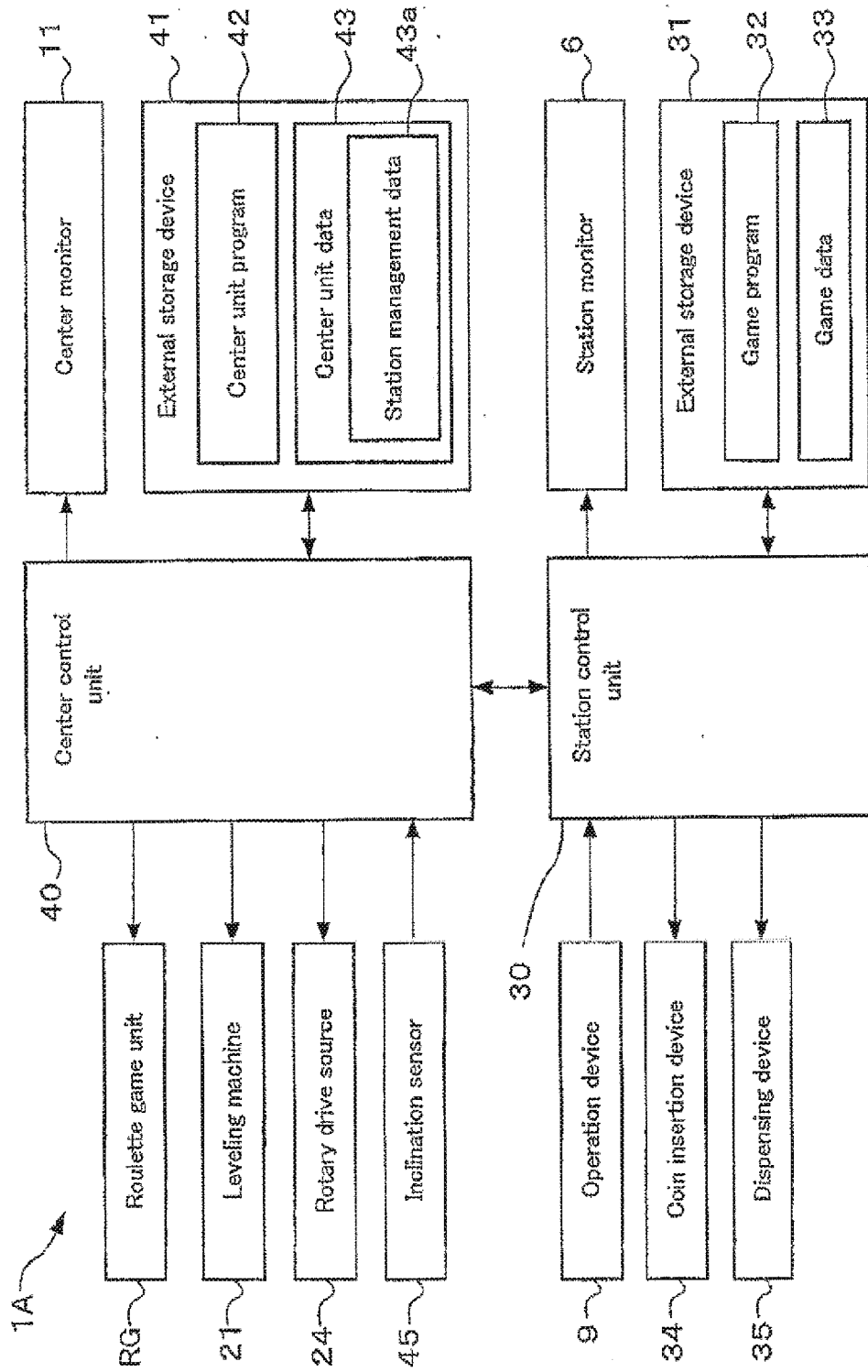

Fig. 4

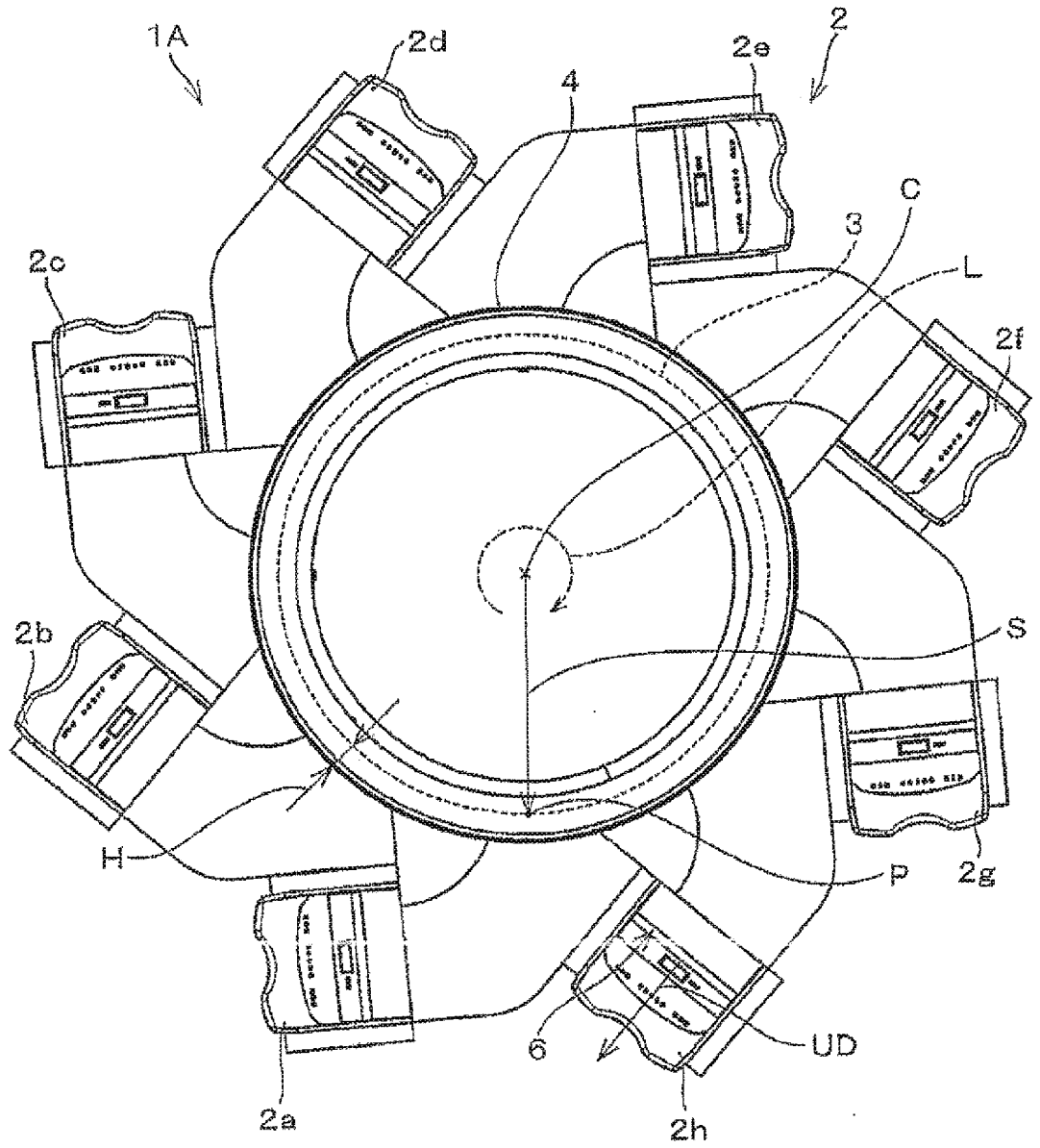

Fig. 5

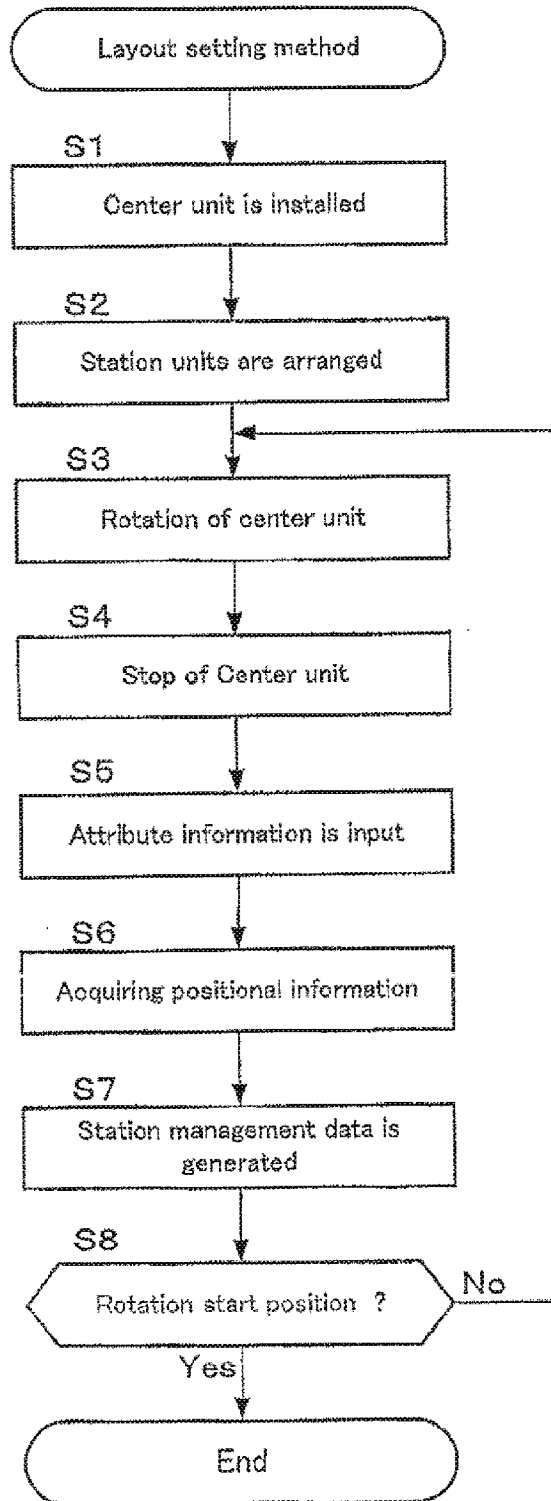

Fig. 6

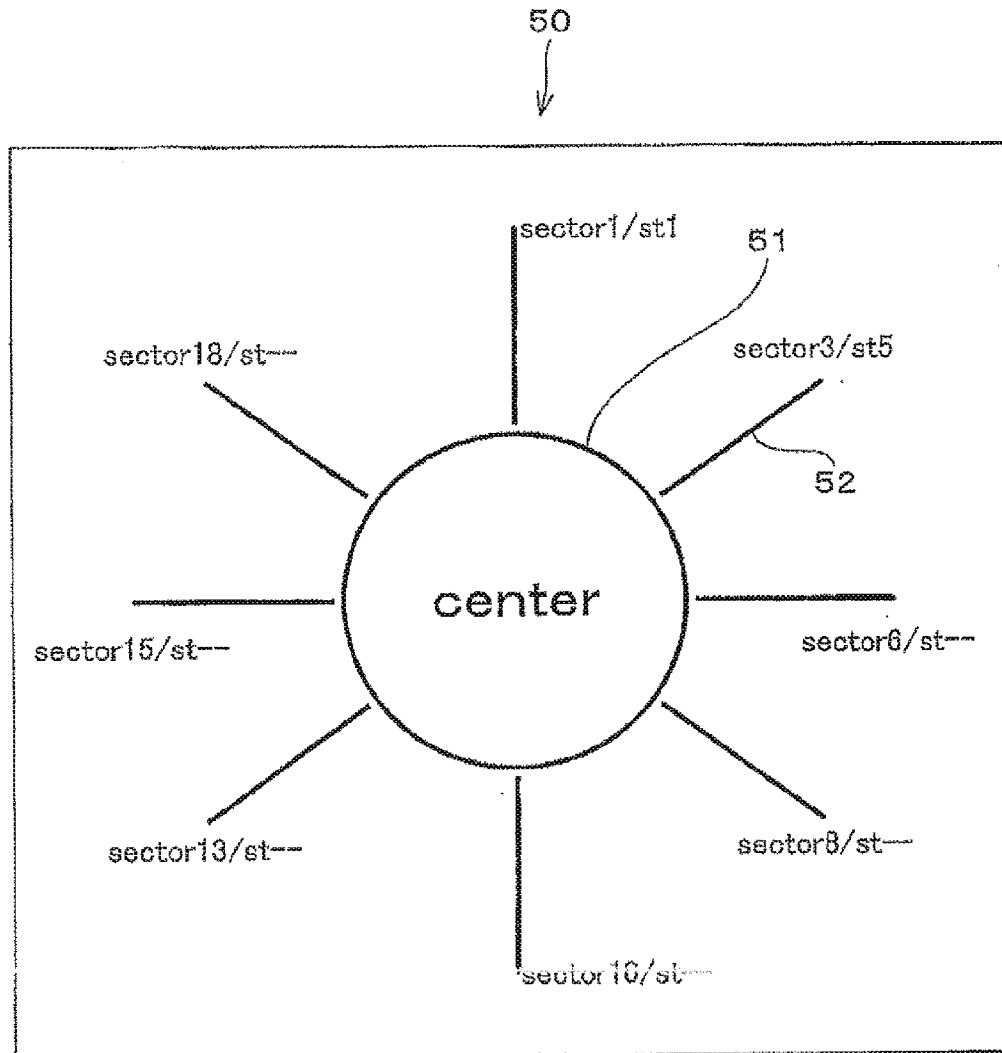

Fig. 7

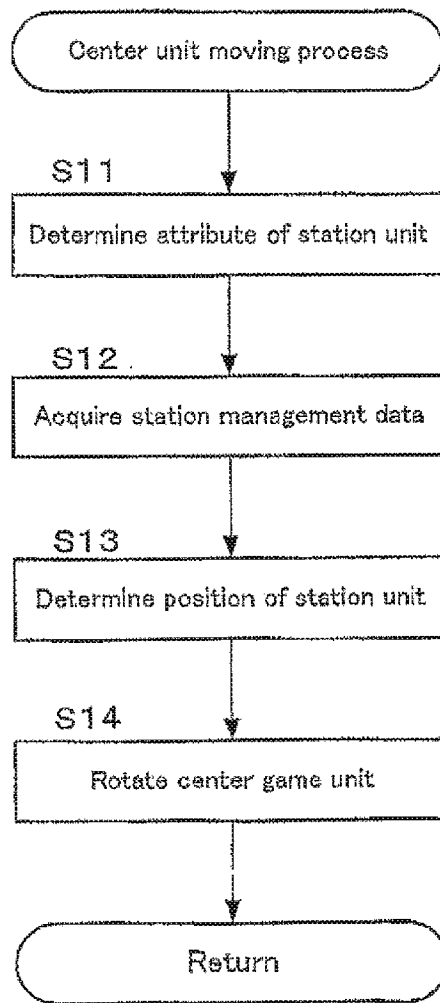

Fig. 9

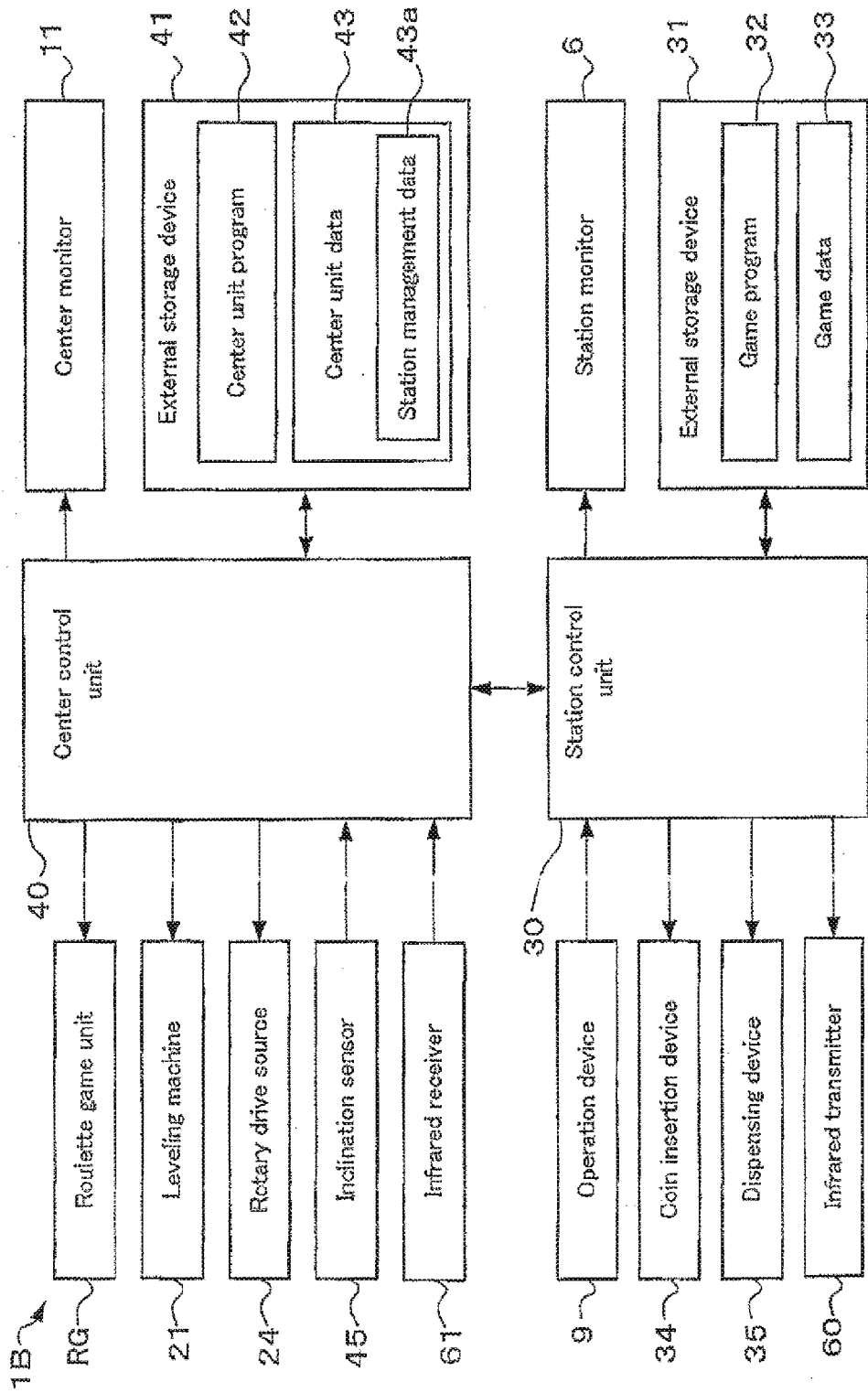

Fig. 10

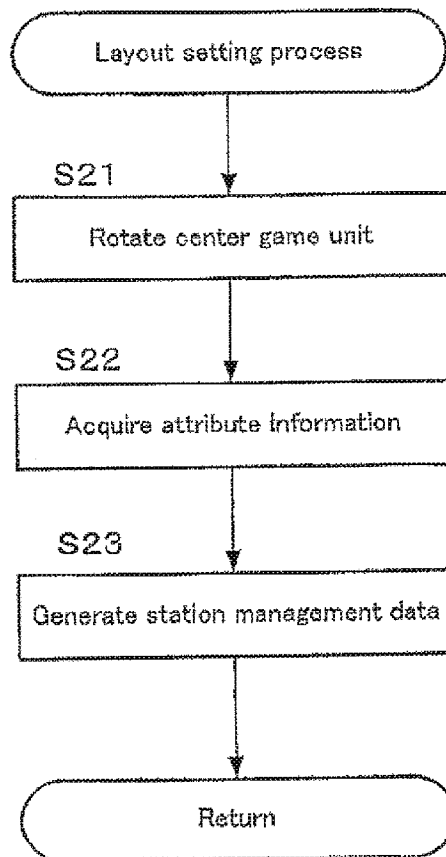

Fig. 11

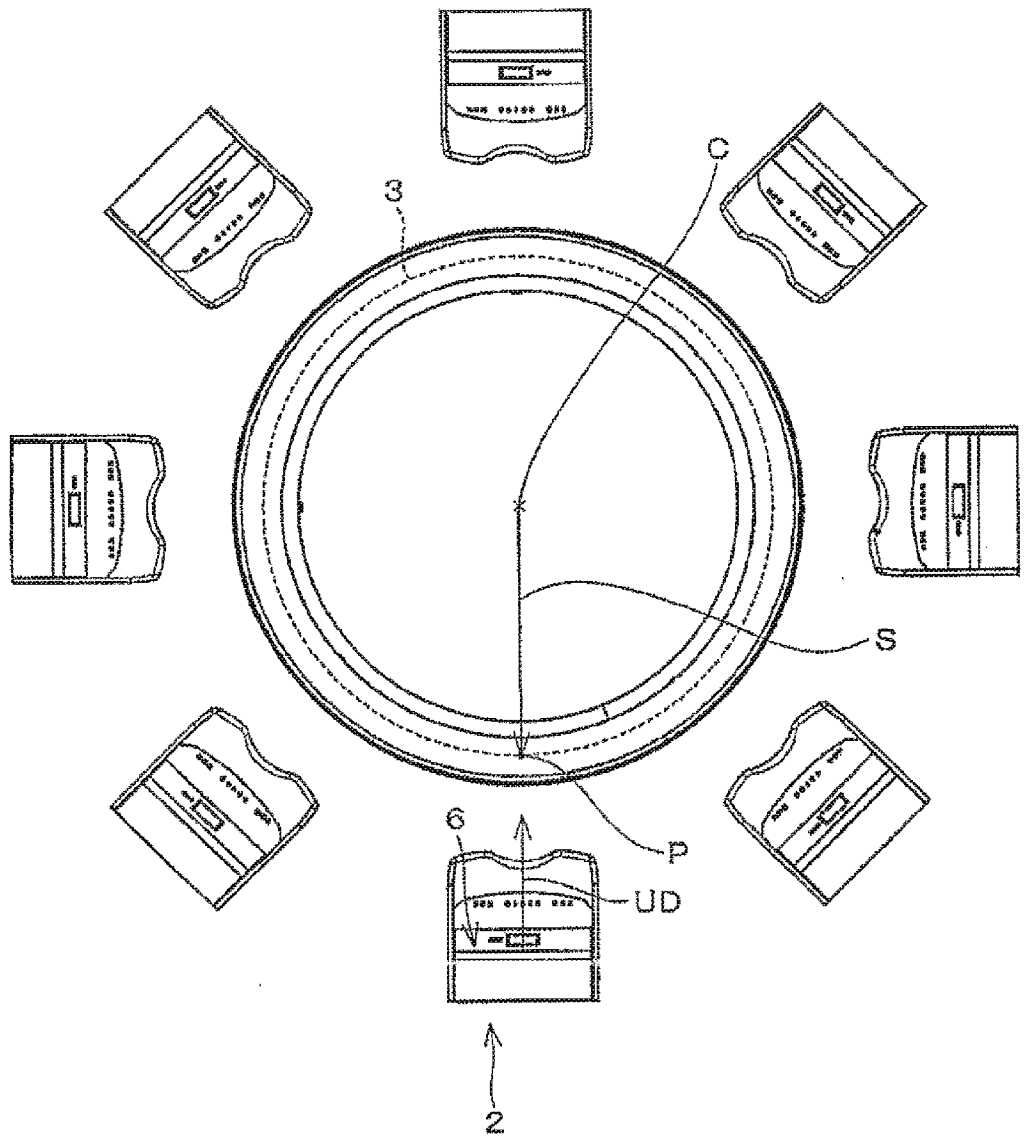

Fig. 12

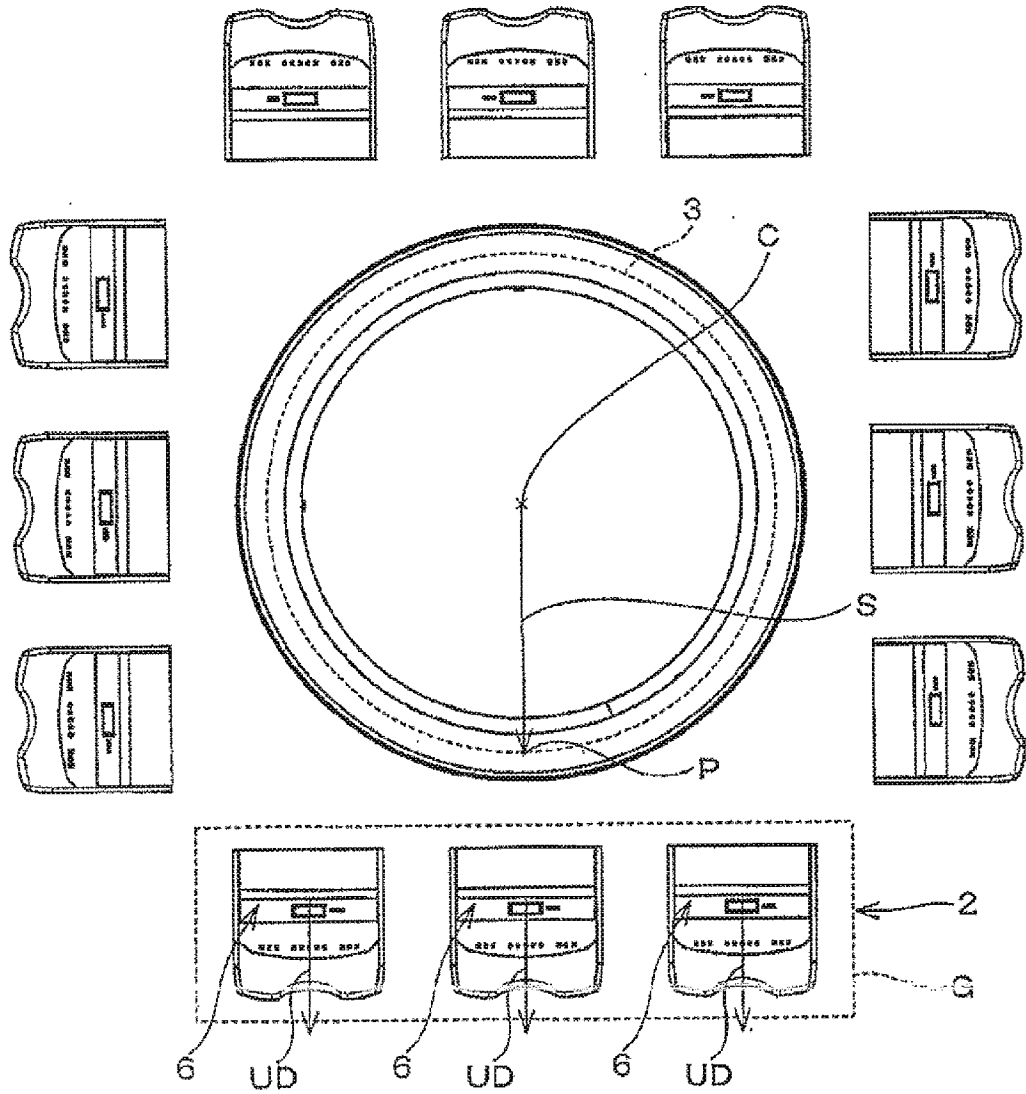

Fig. 13

INTERNATIONAL SEARCH REPORT

International application No.

PCT/US2012/043617

A. CLASSIFICATION OF SUBJECT MATTER IPC(8) - A63F 13/12 (2012.01) USPC - 463/20 According to International Patent Classification (IPC) or to both national classification and IPC		
B. FIELDS SEARCHED Minimum documentation searched (classification system followed by classification symbols) IPC(8) - A63F 5/00, 9/24, 13/00, 13/12 (2012.01) USPC - 463/16, 17, 18, 20 Documentation searched other than minimum documentation to the extent that such documents are included in the fields searched Electronic data base consulted during the international search (name of data base and, where practicable, search terms used) MicroPatent		
C. DOCUMENTS CONSIDERED TO BE RELEVANT		
Category*	Citation of document, with indication, where appropriate, of the relevant passages	Relevant to claim No.
A	US 2009/0176548 A1 (NAKAMURA et al) 09 July 2009 (09.07.2009) entire document	1-7, 11-13
A	US 7,651,392 B2 (PENNINGTON et al) 26 January 2010 (26.01.2010) entire document	1-7, 11-13
A	US 2006/0046837 A1 (ITO et al) 02 March 2006 (02.03.2006) entire document	1-7, 11-13
<input type="checkbox"/> Further documents are listed in the continuation of Box C. <input type="checkbox"/>		
* Special categories of cited documents: "A" document defining the general state of the art which is not considered to be of particular relevance "E" earlier application or patent but published on or after the international filing date "L" document which may throw doubts on priority claim(s) or which is cited to establish the publication date of another citation or other special reason (as specified) "O" document referring to an oral disclosure, use, exhibition or other means "P" document published prior to the international filing date but later than the priority date claimed "T" later document published after the international filing date or priority date and not in conflict with the application but cited to understand the principle or theory underlying the invention "X" document of particular relevance; the claimed invention cannot be considered novel or cannot be considered to involve an inventive step when the document is taken alone "Y" document of particular relevance; the claimed invention cannot be considered to involve an inventive step when the document is combined with one or more other such documents, such combination being obvious to a person skilled in the art "&" document member of the same patent family		
Date of the actual completion of the international search 26 August 2012		Date of mailing of the international search report 21 SEP 2012
Name and mailing address of the ISA/US Mail Stop PCT, Attn: ISA/US, Commissioner for Patents P.O. Box 1450, Alexandria, Virginia 22313-1450 Facsimile No. 571-273-3201		Authorized officer: Blaine R. Copenheaver PCT Helpdesk: 571-272-4300 PCT OSP: 571-272-7774

INTERNATIONAL SEARCH REPORT

International application No.

PCT/US2012/043617

Box No. II Observations where certain claims were found unsearchable (Continuation of item 2 of first sheet)

This international search report has not been established in respect of certain claims under Article 17(2)(a) for the following reasons:

- 1. Claims Nos.:
because they relate to subject matter not required to be searched by this Authority, namely:

- 2. Claims Nos.:
because they relate to parts of the international application that do not comply with the prescribed requirements to such an extent that no meaningful international search can be carried out, specifically:

- 3. Claims Nos.: 8-10
because they are dependent claims and are not drafted in accordance with the second and third sentences of Rule 6.4(a).

Box No. III Observations where unity of invention is lacking (Continuation of item 3 of first sheet)

This International Searching Authority found multiple inventions in this international application, as follows:

- 1. As all required additional search fees were timely paid by the applicant, this international search report covers all searchable claims.
- 2. As all searchable claims could be searched without effort justifying additional fees, this Authority did not invite payment of additional fees.
- 3. As only some of the required additional search fees were timely paid by the applicant, this international search report covers only those claims for which fees were paid, specifically claims Nos.:

- 4. No required additional search fees were timely paid by the applicant. Consequently, this international search report is restricted to the invention first mentioned in the claims; it is covered by claims Nos.:

Remark on Protest

- The additional search fees were accompanied by the applicant's protest and, where applicable, the payment of a protest fee.
- The additional search fees were accompanied by the applicant's protest but the applicable protest fee was not paid within the time limit specified in the invitation.
- No protest accompanied the payment of additional search fees.