



INTERNATIONAL APPLICATION PUBLISHED UNDER THE PATENT COOPERATION TREATY (PCT)

<p>(51) International Patent Classification⁵ : A61F 2/08</p>	<p>A1</p>	<p>(11) International Publication Number: WO 92/16167 (43) International Publication Date: 1 October 1992 (01.10.92)</p>
<p>(21) International Application Number: PCT/GB92/00469 (22) International Filing Date: 16 March 1992 (16.03.92) (30) Priority data: 9105957.6 21 March 1991 (21.03.91) GB (71)(72) Applicant and Inventor: SEEDHOM, Bahaa, Botros [GB/GB]; 28-30 Blenheim Terrace, Leeds LS2 9HD (GB). (72) Inventor; and (75) Inventor/Applicant (for US only) : COLLINS, Simon [GB/GB]; 60 Pye Avenue, Mapplewell, Barnsley S75 6AG (GB). (74) Agent: ORR, William, McLean; Urquhart-Dykes & Lord, Tower House, Merrion Way, Leeds LS2 8PA (GB).</p>		<p>(81) Designated States: AT (European patent), BE (European patent), CH (European patent), DE (European patent), DK (European patent), ES (European patent), FR (European patent), GB, GB (European patent), GR (European patent), IT (European patent), JP, LU (European patent), MC (European patent), NL (European patent), SE (European patent), US.</p> <p>Published <i>With international search report.</i></p>
<p>(54) Title: IMPLANTABLE FIXING DEVICE FOR KNEE LIGAMENT PROSTHESIS</p>		
<p>(57) Abstract</p> <p>A prosthetic ligament fixation system which comprises a prosthetic ligament (15) which can be taken through first and second bone tunnels (13, 14) formed in adjoining bones (11, 12) of a bone joint (10), a first fixing device (16) for holding one end of the ligament at or near to one end (19) of the first bone tunnel (13) and intended to seat itself on the surface of the bone surrounding entrance (19) to the bone tunnel (13) and a second fixing device (18) for holding an opposite end of the ligament (15) at or near to one end of the second bone tunnel (14) in which the first fixing device comprises an annular seating device (20) with an annular bearing surface (20a) on its underside to seat on the surrounding surface of the bone at the entrance (19) to the first bone tunnel (13) and also comprising a U-shaped cradle (22) adjustably mounted on, and extending away from seating device (20) to be located in the first bone tunnel (13) whereby the cradle (22) holds one end of the ligament but is capable of adjusting its position relative to the seating device (20) if necessary, so that the seating device can apply substantially uniform bearing pressure while the ligament (15) can extend along the bone tunnels (13, 14) without coming into engagement with the walls of the tunnels.</p> <div data-bbox="829 1209 1436 1971" style="float: right;"> </div>		

FOR THE PURPOSES OF INFORMATION ONLY

Codes used to identify States party to the PCT on the front pages of pamphlets publishing international applications under the PCT.

AT	Austria	FI	Finland	MI	Mali
AU	Australia	FR	France	MN	Mongolia
BB	Barbados	GA	Gabon	MR	Mauritania
BE	Belgium	GB	United Kingdom	MW	Malawi
BF	Burkina Faso	GN	Guinea	NI	Netherlands
BG	Bulgaria	GR	Greece	NO	Norway
BJ	Benin	HU	Hungary	PL	Poland
BR	Brazil	IE	Ireland	RO	Romania
CA	Canada	IT	Italy	RU	Russian Federation
CF	Central African Republic	JP	Japan	SD	Sudan
CG	Congo	KP	Democratic People's Republic of Korea	SE	Sweden
CH	Switzerland	KR	Republic of Korea	SN	Senegal
CI	Côte d'Ivoire	LI	Liechtenstein	SU	Soviet Union
CM	Cameroon	LK	Sri Lanka	TD	Chad
CS	Czechoslovakia	LU	Luxembourg	TG	Togo
DE	Germany	MC	Monaco	US	United States of America
DK	Denmark	MG	Madagascar		
ES	Spain				

IMPLANTABLE FIXING DEVICE FOR KNEE LIGAMENT PROSTHESIS

This invention relates to an implantable fixing device for securing one end of an elongate flexible tensile element, such as a prosthetic ligament, and to a prosthetic ligament fixation system.

Prosthetic ligaments are being installed in patients to an ever increasing extent, and in one known form comprises a woven structure of implantable material which can be used to join the adjacent ends of a bone joint e.g. the femur to a tibia of a knee joint following ACL replacement surgery.

The prosthetic ligament joins the bones together, and is usually anchored at one end of a reamed-out bone tunnel by a suitable fixing device, and at its other end by a bone staple. One known type of prosthetic ligament is disclosed in more detail in EP 126520, and has a pouch near one end in which a bone plug can be introduced, and which anchors this end of the ligament at the entrance to the bone tunnel, and with the ligament being threaded through the bone tunnels formed in the femur and the tibia, and having its free end anchored by a bone staple driven into a suitable bone site and thereby trapping the ligament end.

The use of a woven prosthetic ligament has the advantage of providing a durable implantable tensile element with a long service life, and which allows tissue ingrowth over a period of time to improve the anchorage of the ends of the ligaments.

However, prosthetic ligaments do not need to be made of synthetic i.e. man made material, and there is also use of prosthetic ligaments built-up from naturally available material (autogenous tissue) which may be "harvested" from a patient undergoing surgery which involves the need for a replacement ligament.

Semi-tendinosus or gracilis tissue can be used for this purpose, which is formed into a prosthetic ligament bundle looped at one end around a fixing or anchoring device, and

the use of this procedure is particularly favoured by US surgeons.

In one aspect, the present invention is concerned with a novel fixing device for securing one end of an implantable flexible tensile element, such as a prosthetic ligament of any suitable material, which will include an implantable woven ligament and also naturally available material which can be formed into a prosthetic ligament, as well as other flexible tensile implantable elements, such as a suture.

In a further aspect, the invention is concerned with a prosthetic ligament fixation system.

In ACL replacement surgery, usually the upper end of the prosthetic ligament is anchored near the upper end of a bone tunnel reamed out of the femur, whereas the lower end of the ligament extends beyond the lower end of the tunnel reamed out of the tibia and this lower projecting end is anchored by a bone staple driven into a suitable site on the tibia with the end of the ligament being trapped under the bar or cross piece of the staple.

In order to secure the upper end of the ligament reliably in position, it is important to provide a fixing device which can bear on the surface of the bone surrounding the entrance to the bone tunnel formed in the femur, as this has the required strength and wear resistance to withstand the loads which will be applied to the fixing device by the ligament during articulation of the knee joint.

However, the surrounding surface of the bone is not always uniformly smooth, and neither is it always truly perpendicular to the general axis of the bone tunnel. This gives rise to a problem, in that the ligament has to be looped around a part of the fixing device, and then is able to apply a tensile force to the fixing device in a direction generally along the axis of the tunnel, which can cause improper seating of the fixing device on the surface of the bone surrounding the entrance to the tunnel, which can give rise to non-uniform bearing pressure, or to localised high pressure contact areas. Clearly, this is undesirable, as it

may be the cause of unreliability, and also may result in accelerated wear of the bone surface, and ultimately in slippage of the fixing device with resulting loss of tension in the ligament.

The present invention therefore addresses this problem, and seeks to provide an improved seating of the fixing device on the surrounding bone surface, while permitting satisfactory attachment of the ligament around a part of the fixing device.

According to a first aspect of the invention there is provided a prosthetic fixation system comprising:

a prosthetic ligament which can be taken through first and second bone tunnels formed in adjoining bones of a bone joint:

a first fixing device for holding one end of the ligament at or near to one end of the first bone tunnel, said fixing device being intended to seat itself on the surface of the bone surrounding an entrance to said one end of the first bone tunnel: and

a second fixing device for holding an opposite end of the ligament at or near to one end of the second bone tunnel:

in which the first fixing device comprises a seating device having an annular bearing surface to seat on said surrounding surface at the entrance to the first bone tunnel: and a cradle adjustably mounted on, and extending away from the seating device to be located in the first bone tunnel, said cradle serving to hold one end of the ligament and being capable of adjusting its position relative to the seating device, if necessary, so that the seating device can apply substantially uniform bearing pressure via its annular bearing surface while the ligament can extend along the bone tunnels without coming into engagement with the walls of the tunnels.

According to a further aspect of the invention there is provided an implantable fixing device for securing one end of a flexible elongate element, such as a prosthetic ligament, which is taken through first and second bone tunnels formed

in adjoining bones of a bone joint, said fixing device being intended to seat itself on the surface of the bone surrounding an entrance to one of the bone tunnels, and said device comprising:

a seating device which is shaped so as to seat at least partly on said surrounding bone surface; and

a cradle which is adjustably mounted on, and extends away from the seating device to be located in the first bone tunnel, said cradle serving to hold one end of the ligament and being capable of adjusting its position relative to the seating device, if necessary, so that the seating device can apply substantially uniform bearing pressure via an annular bearing surface while the ligament can extend along the bone tunnels without coming into engagement with the walls of the tunnels.

Preferably, the seating device comprises a collar, and the cradle is pivotally mounted on this collar.

The cradle may be U-shaped having a base around which the ligament can be looped, and a pair of parallel legs connected to the base and which are pivotally mounted at their free ends on the collar.

The free ends of the legs may have lugs which can seat each on a respective one of a pair of diametrically opposed seating recesses formed in the collar, and preferably these lugs are out-turned lugs. This therefore allows the U-shaped cradle to be mounted on the collar by inward deformation of the free ends of the legs, or by relative slidable movement of the base and legs through the collar until the lugs become seated on the respective seating recesses.

In a particularly preferred arrangement, a plug can be positioned within the cradle to occupy at least part of the entrance portion of the first bone tunnel, and preferably the plug is a bone plug derived from the bone material reamed out during formation of the bone tunnels, and preferably shaped so as to be able to fit within and to engage with the cradle, but also to have at least part of its outer surface located closely adjacent to the inner wall of the adjacent part of

the bone tunnel. This will promote boney ingrowth from the wall of the tunnel to join with the bone plug and the cradle over a period of time, to further improve the anchoring of the elongate element e.g a ligament.

The end of the ligament remote from the cradle and seating device is preferably anchored in position by use of a fastening staple or bone staple, which can be driven into the bone near the exit of the ligament from the second bone tunnel.

The prosthetic ligament may be manufactured from woven implantable material, or may be derived from autogenous tissue harvested from the patient. Alternatively, the elongate implantable element may comprise a suture e.g of the type used with patellar tendon bone block grafts.

One embodiment of implantable fixing device, and of prosthetic ligament fixation system, according to the invention will now be described in detail, by way of example only, with reference to the accompanying drawings in which:

Figure 1 is a schematic illustration of an implantable fixing device being used to anchor the upper end of a prosthetic ligament derived from autogenous tissue and used in ACL replacement surgery:

Figures 2a and 2b are, respectively, a plan view and a side view of a collar of the fixing device shown in Figure 1; and.

Figure 3 is a side view of a cradle which inter-fits with the collar shown in Figure 2 in order to complete the assembly of the fixing device.

Referring now the drawings, there will be described, by way of example only, the use of a fixing device to secure the upper end of a prosthetic ligament derived from autogenous tissue and used in ACL replacement surgery. This is merely one example of a type of implantable flexible elongate tensile element with which the fixing device of the invention may be used. This example also comprises an embodiment of prosthetic ligament fixation system according to the invention.

-6-

Referring particularly to Figure 1, this shows a typical knee joint 10 comprising a femur 11 and tibia 12, and through which have been formed, by reaming-out, aligned bone tunnels 13 and 14 respectively, for ACL replacement surgery. A prosthetic ligament 15 is shown extending through the tunnels 13 and 14, and is derived from autogenous tissue e.g. semi-tendinosus/gracilis material. The upper end of the prosthetic ligament 15 is looped around a fixing device according to the invention which is designated generally by reference 16, whereas the lower end 17 of the ligament projects beyond the lower end of bone tunnel 14 and can be anchored in position by a bone staple 18 e.g. of the type disclosed in WO 91/06249 which is driven into a suitable site in the tibia 12, thereby trapping the ligament end 17 securely.

The walls of the bone tunnels 13 and 14 are relatively soft, and therefore to secure reliably the upper end of the prosthetic ligament, it is important to provide a fixing device 16 which can seat itself reliably upon the bone surface surrounding the entrance 19 to the bone tunnel 13, which is sufficiently strong and wear resistant.

The construction of fixing device 16 is shown in more detail in Figures 2 and 3, and comprises a seating device in the form of a collar 20 which is shaped so as to seat on at least part of the annular bone surface surrounding the entrance 19 to bone tunnel 13 (via annular bearing surface 20a on its underside), and which has a through-hole 21 formed in the collar 20.

The fixing device 16 also includes a U-shaped cradle or stirrup 22 which is capable of being taken through the hole 21 in the collar 20 upon assembly, cradle 22 having a base 23 around which prosthetic ligament 15 can be taken, a pair of parallel legs 24 connected to the base 23, and a pair of out-turned lugs 25 on the free ends of the legs 24.

The lugs 25 are preferably out-turned and can seat each on a respective one of a pair of diametrically opposed seating recesses 26 formed in the collar 20 in order to

complete the assembly, and provide a pivotally adjustable mounting of the cradle 22 on collar 20.

The collar 20 therefore can seat itself reliably and with substantially uniform bearing pressure upon the surrounding bone surface, and the cradle 22 can pivotally adjust itself, as necessary, via rocking engagement of lugs 25 on the seating recesses 26 so that the ligament 15 can extend along the bone tunnels 13 and 14 without snagging or other engagement with the walls of the tunnels.

The collar 20 is annular, and defines a circular hole through which the legs 24 of the cradle 22 can be taken upon assembly, until the lugs 25 come into engagement with the seating recesses 26. Alternatively, the legs 24 can be inwardly deformed to allow the ends of the legs 24 to pass through the collar, and then release of the deformation allows lugs 25 to snap-out into engagement with the recesses 26.

As can be seen from Figure 1, a bone plug 27 can complete the fixing device, and which is introduced through the hole 21 and which fits generally within the confines of the legs 24 and the base 23 of the cradle 22. The bone plug conveniently is fashioned from the bone material reamed-out during formation of the bone tunnels 13 and 14, and preferably is shaped so as to be able to fit within and to engage with the cradle, but also to have at least part of its outer surface closely adjacent to the wall of bone tunnel 13. This will promote boney ingrowth from the wall of the tunnel to join with the bone plug and the cradle over a period of time, to further improve the anchoring of the ligament.

The bone staple 18 preferably comprises a bone staple of the type disclosed in more detail in International publication WO 91/06249.

Instead of use of autogenous tissue to form the prosthetic ligament 15, the prosthetic ligament may comprise a synthetic device e.g of the type disclosed in more detail in EP 126520. Alternatively, the fixing device 16 of the invention may be used to secure one end of another type of

-8-

flexible implantable elongate device than a ligament. e.g. a suture of the type used with patellar tendon bone block grafts.

CLAIMS

1. A prosthetic ligament fixation system comprising:
 - a prosthetic ligament (15) which can be taken through first and second bone tunnels (13, 14) formed in adjoining bones (11, 12) of a bone joint (10);
 - a first fixing device (16) for holding one end of the ligament (15) at or near to one end (19) of the first bone tunnel (13), said fixing device being intended to seat itself on the surface of the bone surrounding an entrance (19) to said one end of the first bone tunnel (13); and
 - a second fixing device (18) for holding an opposite end (17) of the ligament (15) at or near to one end of the second bone tunnel (14);in which the first fixing device (16) comprises a seating device (20) having an annular bearing surface (20a) to seat on said surrounding surface at the entrance (19) to the first bone tunnel (13); and a cradle (22) adjustably mounted on, and extending away from the seating device (20) to be located in the first bone tunnel (13), said cradle (22) serving to hold one end of the ligament (15) and being capable of adjusting its position relative to the seating device (20), if necessary, so that the seating device (20) can apply substantially uniform bearing pressure via its annular bearing surface (20a) while the ligament (15) can extend along the bone tunnels (13, 14) without coming into engagement with the walls of the tunnels.
2. A fixation system according to claim 1, in which the seating device comprises a collar (20), and said cradle (22) is pivotally mounted on said collar.
3. A fixation system according to claim 2, in which the cradle (22) is U-shaped having a base (23) around which the ligament (15) can be looped, and a pair of parallel legs (24) connected to the base (23) and which are pivotally mounted at their free ends (25) on said collar (20).

-10-

4. A fixation system according to claim 3 in which the free ends of the legs (24) have lugs (25) which can seat each on a respective one of a pair of diametrically opposed seating recesses (26) formed in the collar (20).

5. A fixation system according to claim 4. in which the lugs (25) are out-turned lugs which allow the U-shaped cradle (22) to be mounted on the collar (20) by inward deformation of the free ends of the legs (24), or by a relative slidable movement of the base (23) and legs (24) through the collar until the lugs (25) become seated on the respective seating recesses (26).

6. A fixation system according to any one of claims 3 - 5, including a plug (27) positionable with the cradle (22) to occupy at least part of the entrance portion (19) of said first bone tunnel (13).

7. A fixation system according to claim 6. in which the plug is a bone plug (27) derived from material extracted during the formation of the bone tunnels (13, 14) formed in the bones (11, 12) of the patient.

8. A fixation system according to any one of claims 1 - 7, in which the second fixing device comprises a bone staple (18).

9. An implantable fixing device (16) for securing one end of a flexible elongate element (15), such as a prosthetic ligament, which is taken through first and second bone tunnels (13, 14) formed in adjoining bones (11, 12) of a bone joint (10), said fixing device being intended to seat itself on the surface of the bone surrounding an entrance (19) to one of the bone tunnels (13), and said device comprising:

a seating device (20) which is shaped so as to seat at least partly on said surrounding bone surface; and

a cradle (22) which is adjustably mounted on, and

-11-

extends away from the seating device (20) to be located in the first bone tunnel (13). said cradle serving to hold one end of the ligament (15) and being capable of adjusting its position relative to the seating device (20). if necessary. so that the seating device can apply substantially uniform bearing pressure via an annular bearing surface (20a) while the ligament (15) can extend along the bone tunnels (13, 14) without coming into engagement with the walls of the tunnels (13, 14).

10. An implantable fixing device according to claim 9. in which the seating device comprises a collar (20). and said cradle (22) is pivotally mounted on said collar.

11. An implantable fixing device according to claim 10. in which the cradle (22) is U-shaped having a base (23) around which the ligament (15) can be looped. and a pair of parallel legs (24) connected to the base (23) and which are pivotally mounted at their free ends (25) on said collar (20).

12. An implantable fixing device according to claim 11. in which the free ends of the legs (24) have lugs (25) which can seat each on a respective one of a pair of diametrically opposed seating recesses (26) formed in the collar (20).

13. An implantable fixing device according to claim 12. in which the lugs are out-turned lugs (25) which allow the U-shaped cradle (22) to be mounted on the collar (20) by inward deformation of the free ends of the legs (24). or by a relative slidable movement of the base (23) and legs (24) through the collar until the lugs (25) become seated on the respective seating recesses (26).

14. An implantable fixing device according to any one of claims 9 to 13. in combination with said flexible elongate element. in which said elongate element (25) comprises a prosthetic ligament or a suture.

-12-

15. An implantable fixing device according to claim 15. in which the elongate element comprises a prosthetic ligament (15) made of woven implantable material. or made from autogenous tissue derived from the patient.

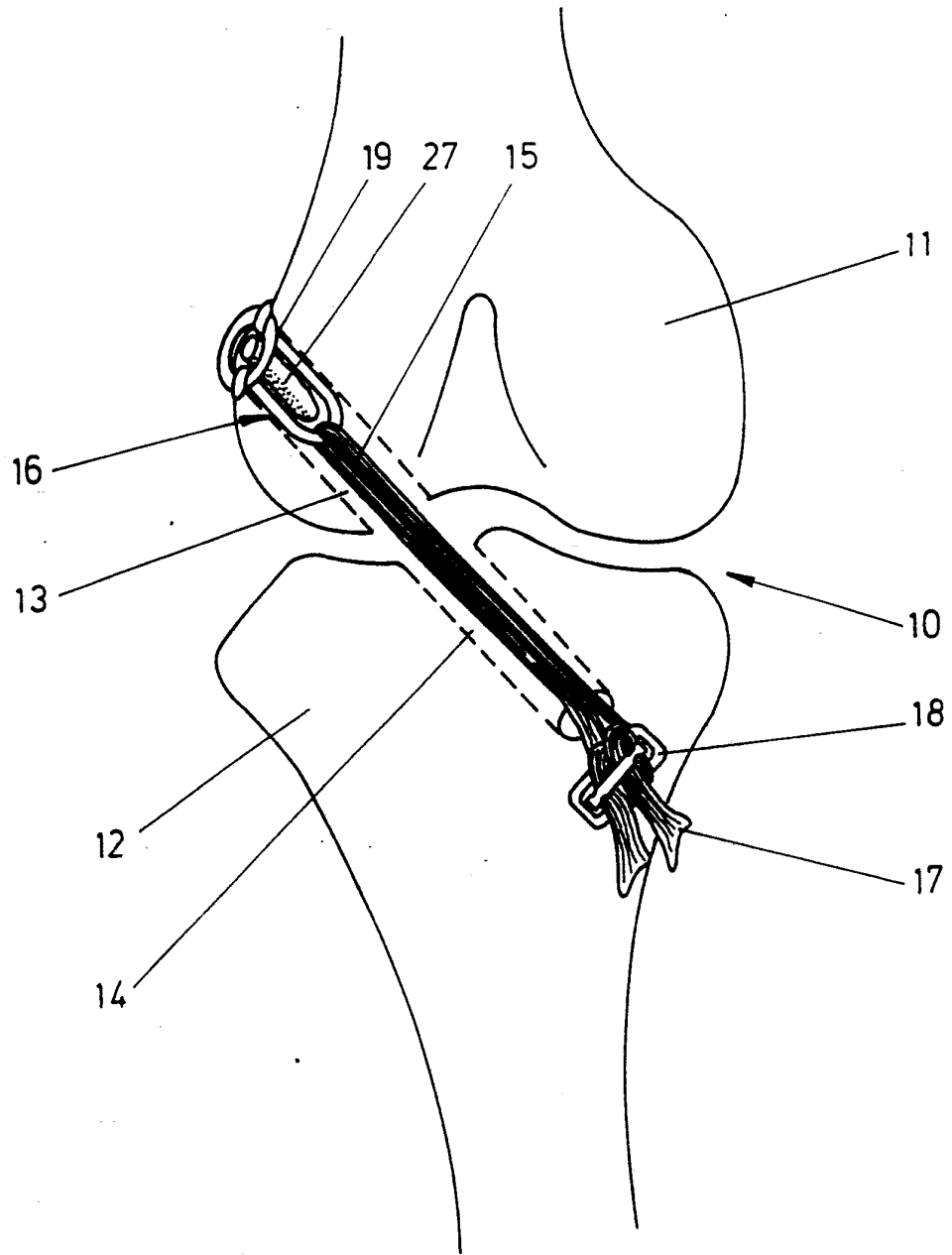

FIG. 1

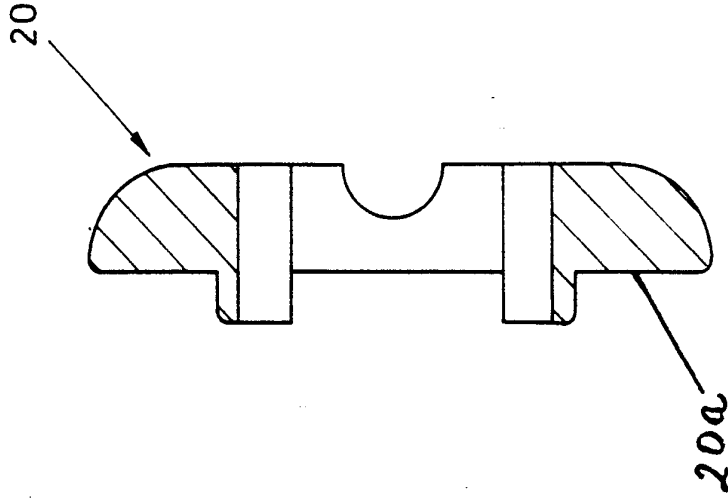

FIG. 2a

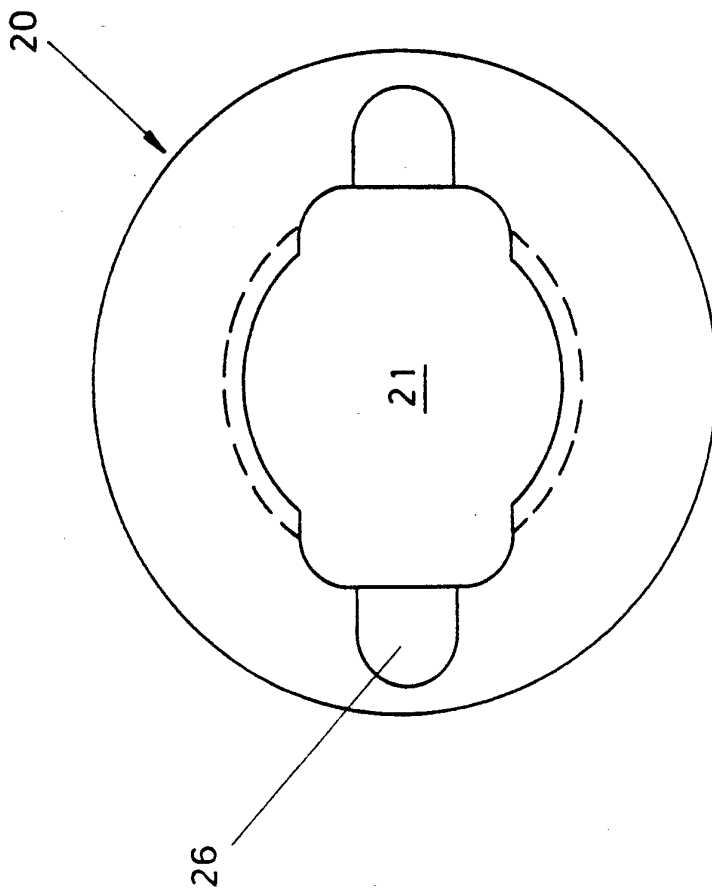

FIG. 2b

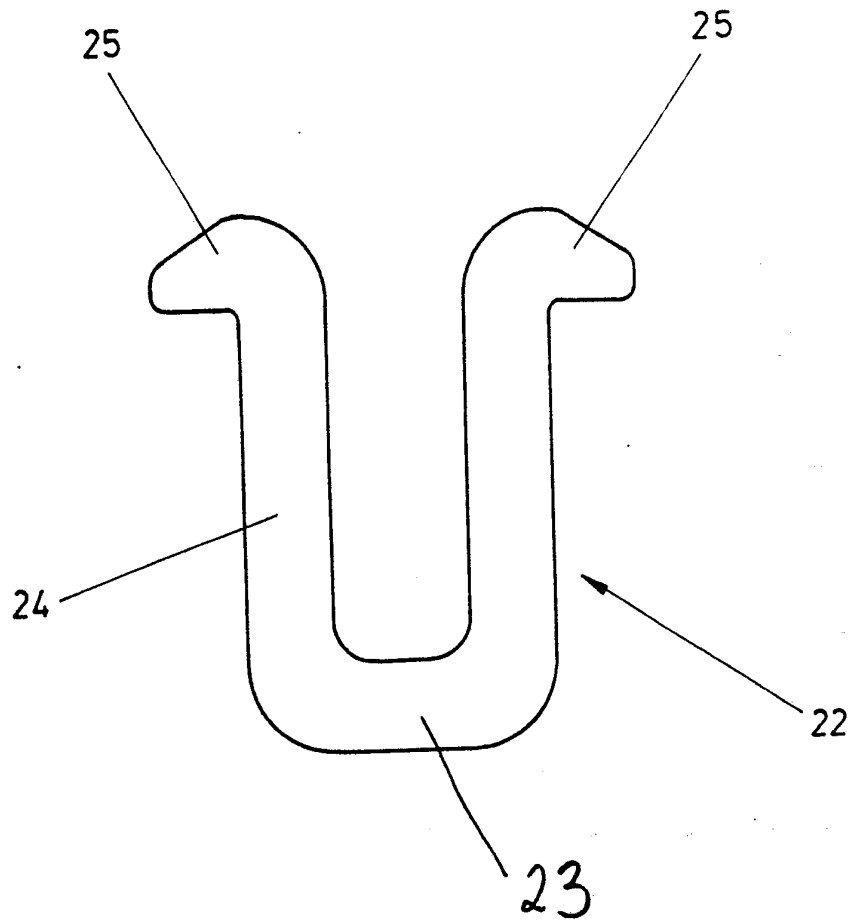
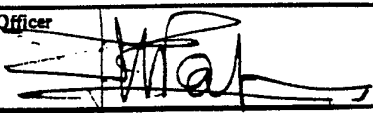

FIG. 3

INTERNATIONAL SEARCH REPORT

PCT/GB 92/00469

International Application No

I. CLASSIFICATION OF SUBJECT MATTER (if several classification symbols apply, indicate all) ⁶		
According to International Patent Classification (IPC) or to both National Classification and IPC Int.Cl. 5 A61F2/08		
II. FIELDS SEARCHED		
Minimum Documentation Searched ⁷		
Classification System	Classification Symbols	
Int.Cl. 5	A61F ; A61B	
Documentation Searched other than Minimum Documentation to the Extent that such Documents are Included in the Fields Searched ⁸		
III. DOCUMENTS CONSIDERED TO BE RELEVANT⁹		
Category ¹⁰	Citation of Document, ¹¹ with indication, where appropriate, of the relevant passages ¹²	Relevant to Claim No. ¹³
A	FR,A,2 395 012 (GENERAL ATOMIC COMPANY) 19 January 1979 see page 8, line 4 - line 10; figure 2 ---	1,9
A	DE,U,9 002 844 (GIERS) 6 December 1990 see the whole document ---	1,9
A	FR,A,2 590 792 (BREARD) 5 June 1987 see abstract; figure 2 ---	1,9
<p>¹⁰ Special categories of cited documents:</p> <p>"A" document defining the general state of the art which is not considered to be of particular relevance</p> <p>"E" earlier document but published on or after the international filing date</p> <p>"L" document which may throw doubts on priority claim(s) or which is cited to establish the publication date of another citation or other special reason (as specified)</p> <p>"O" document referring to an oral disclosure, use, exhibition or other means</p> <p>"P" document published prior to the international filing date but later than the priority date claimed</p> <p>"T" later document published after the international filing date or priority date and not in conflict with the application but cited to understand the principle or theory underlying the invention</p> <p>"X" document of particular relevance; the claimed invention cannot be considered novel or cannot be considered to involve an inventive step</p> <p>"Y" document of particular relevance; the claimed invention cannot be considered to involve an inventive step when the document is combined with one or more other such documents, such combination being obvious to a person skilled in the art.</p> <p>"&" document member of the same patent family</p>		
IV. CERTIFICATION		
Date of the Actual Completion of the International Search	Date of Mailing of this International Search Report	
27 APRIL 1992	15. 05. 92	
International Searching Authority	Signature of Authorized Officer	
EUROPEAN PATENT OFFICE	PAPONE F. 	

**ANNEX TO THE INTERNATIONAL SEARCH REPORT
ON INTERNATIONAL PATENT APPLICATION NO. GB 9200469
SA 57538**

This annex lists the patent family members relating to the patent documents cited in the above-mentioned international search report. The members are as contained in the European Patent Office EDP file on The European Patent Office is in no way liable for these particulars which are merely given for the purpose of information. 27/04/92

Patent document cited in search report	Publication date	Patent family member(s)	Publication date
FR-A-2395012	19-01-79	US-A- 4149277	17-04-79
		CA-A- 1111604	03-11-81
		DE-A- 2827006	18-01-79
		GB-A- 1593700	22-07-81
		JP-C- 1339175	29-09-86
		JP-A- 54010597	26-01-79
		JP-B- 61003498	01-02-86

DE-U-9002844	06-12-90	None	

FR-A-2590792	05-06-87	None	
