

C. H. BROOKS.
MACHINE FOR MAKING PAPER BOXES.

(Application filed Nov. 15, 1898.)

5 Sheets—Sheet 2.

(No Model.)

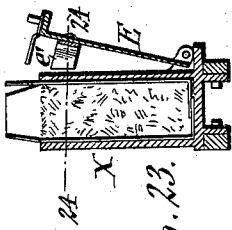

Fig. 23.



Fig. 24.

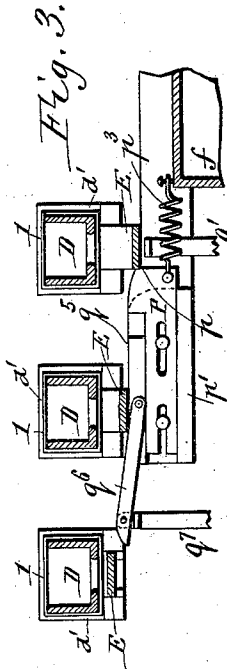
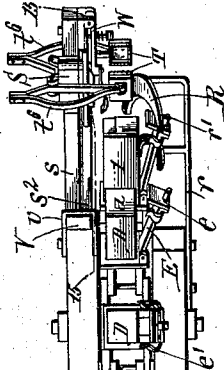

Fig. 3.

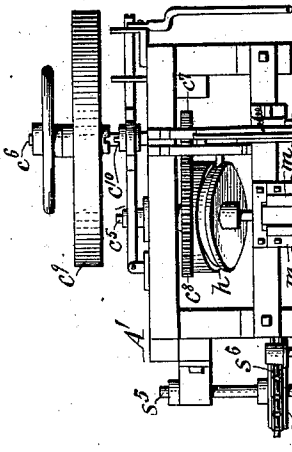

Fig. 22.

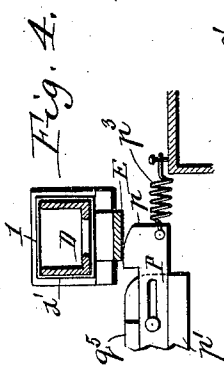
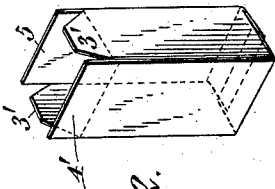

Fig. 4.

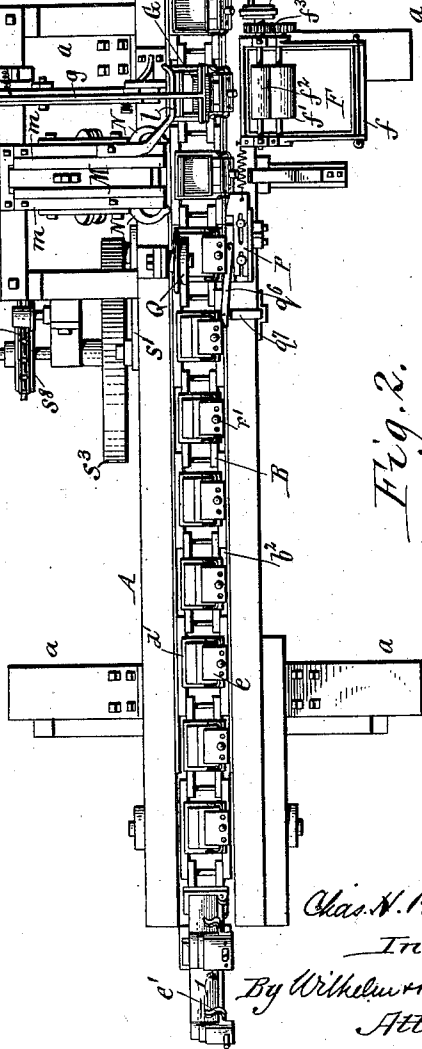

Fig. 2.

Witnesses:
Henry L. Deck.
Chas. F. Burkhardt

Chas. H. Brooks,
Inventor.
By Wilhelm & Pomeroy,
Attorneys.

C. H. BROOKS.
MACHINE FOR MAKING PAPER BOXES.

(Application filed Nov. 15, 1898.)

(No Model.)

5 Sheets—Sheet 4.

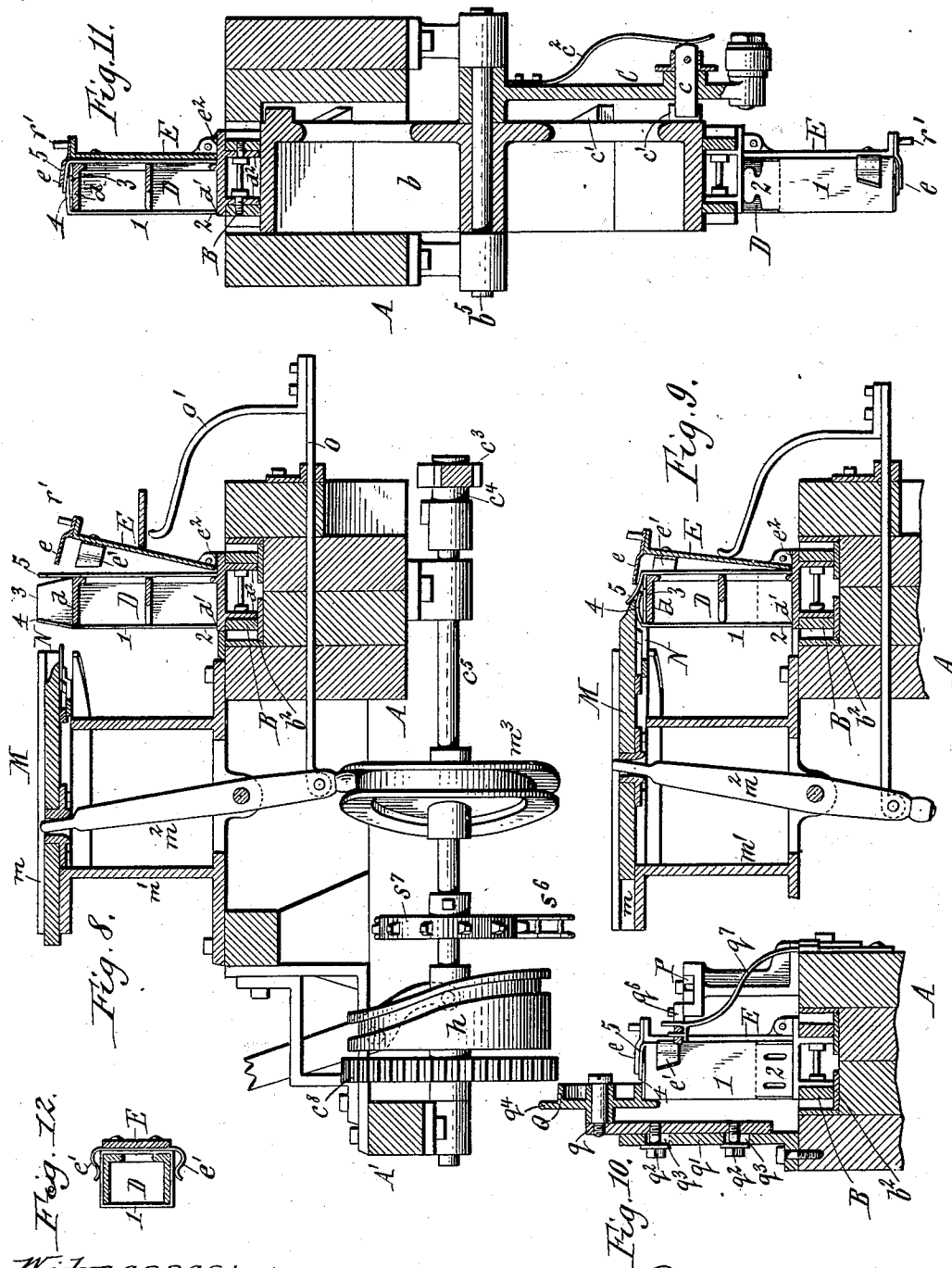

Witnesses:
 Henry L. Deck.
 Chas. F. Burkhardt.

Chas. H. Brooks, Inventor.
 By Wilhelm & Fowler
 Attorneys.

C. H. BROOKS.
MACHINE FOR MAKING PAPER BOXES.

(Application filed Nov. 15, 1898.)

(No Model.)

5 Sheets—Sheet 5.

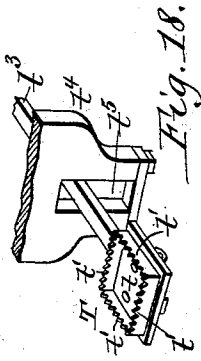
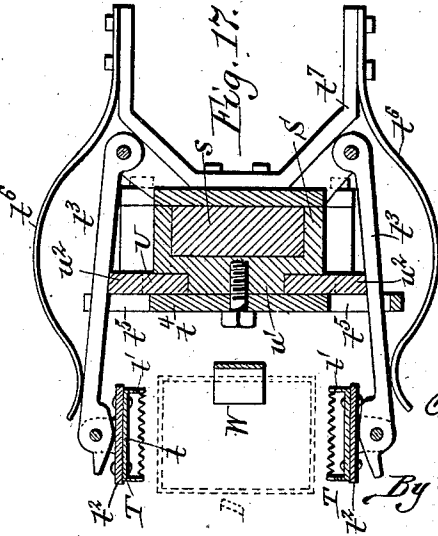
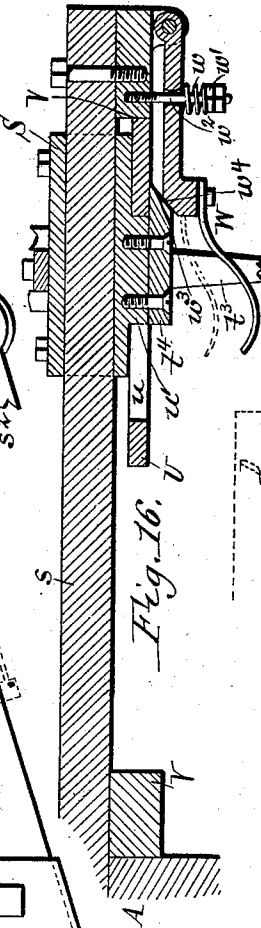
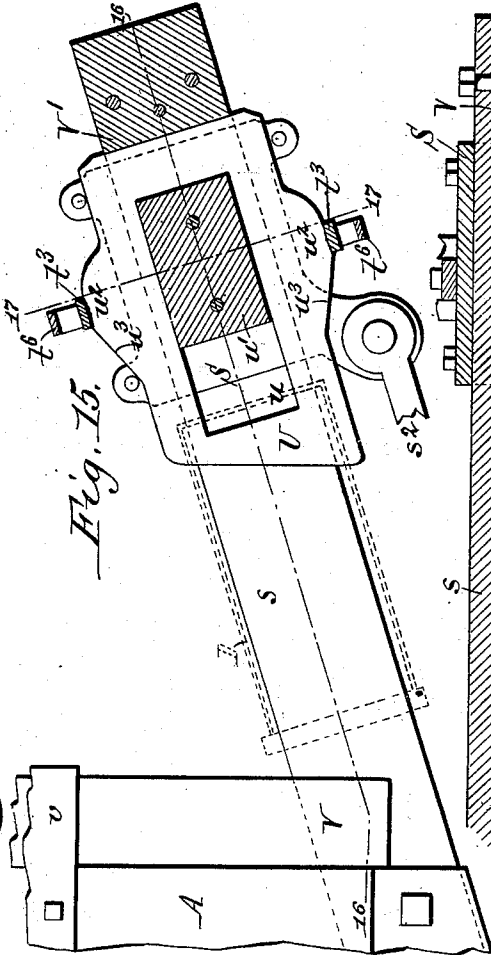
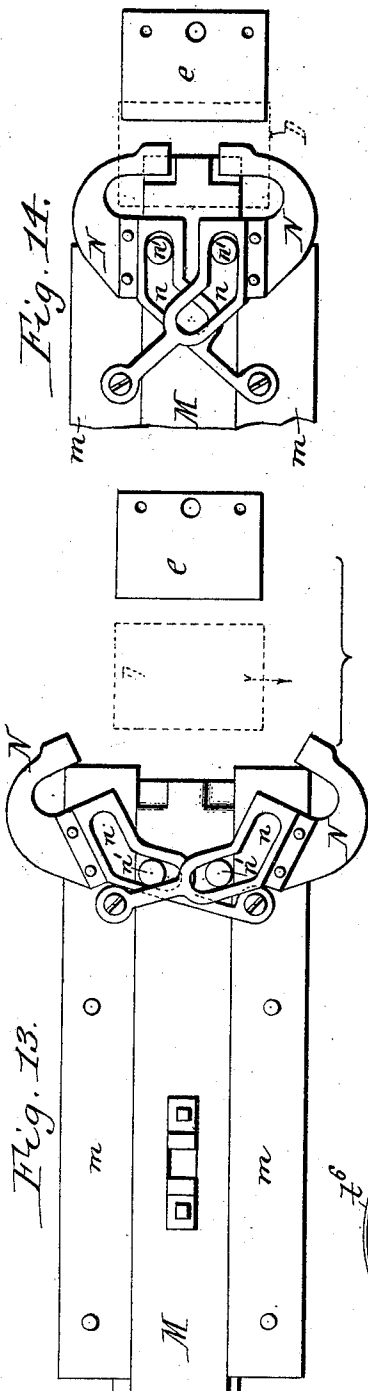

Witnesses:
Henry L. Deck.
Chas. F. Burkhart.

Chas. H. Brooks,
Inventor.
By Wilhelm & Bonner,
Attorneys.

UNITED STATES PATENT OFFICE.

CHARLES H. BROOKS, OF SYRACUSE, NEW YORK, ASSIGNOR TO THE
MERRELL-SOULE COMPANY, OF SAME PLACE.

MACHINE FOR MAKING PAPER BOXES.

SPECIFICATION forming part of Letters Patent No. 664,458, dated December 25, 1900.

Application filed November 15, 1898. Serial No. 896,509. (No model.)

To all whom it may concern:

Be it known that I, CHARLES H. BROOKS, a citizen of the United States, residing at Syracuse, in the county of Onondaga and State of New York, have invented new and useful Improvements in Machines for Making Paper Boxes, of which the following is a specification.

This invention relates to a machine which is more especially designed for closing the bottoms of the four-sided paper or cardboard boxes or cartons which are used for putting up various kinds of merchandise—for instance, dry or comparatively dry food preparations. In these boxes the bottom is composed of four flaps—two side flaps, which are folded down first, a rear flap, which is folded against and pasted to the side flaps, and a front flap, which is folded against and pasted to this rear flap.

The object of this invention is to produce a machine which embodies automatic mechanisms by which the paste is automatically applied to the rear and front flaps, the four flaps are closed down, and the box or carton is ejected after the paste has dried.

The mechanisms which are embodied in my improved machine are, briefly stated, the following: An intermittently-moving endless feed-chain or traveling carrier is provided with numerous four-sided holders, on each of which a box or carton blank is placed in an inverted position by the operator as the holders pass by the operator. In this position the four bottom flaps of the blank project upwardly from each holder and are in this position presented by the movement of the feed-chain to the paste-applying mechanism, which latter applies the paste, gum, or mucilage to the rear and front flaps. The following movements of the feed-chain present the blank to the mechanisms by which the two side flaps are folded upon the top of the holder, the gummed rear flap is folded down upon the side flaps, and the gummed front flap is folded down upon the rear flap. All of these operations take place on the upper portion of the horizontal feed-chain from which the four-sided blank-holders project upwardly, while they project downwardly from the lower portion of the chain. The

feed-chain is made so long that the paste, gum, or mucilage dries while the boxes, of which the bottoms have been closed, travel with the chain. After the bottoms have become dry the boxes are presented to an ejecting mechanism, by which each box is removed from its holder. The tops of these boxes or cartons are also each composed of four flaps; but these remain open until the box has been filled and are usually so constructed that they must be closed by hand. When the top flaps are also so constructed that they can be secured by pasting, the herein-described mechanisms for applying the paste and folding the flaps can be used for performing these operations in closing the boxes after they have been filled. In that case a second machine is provided which has the holders on the feed-chain constructed to receive the filled boxes, with the top flaps projecting upwardly therefrom, the gumming or pasting mechanism and the folding mechanism being constructed and arranged to operate as in the first-mentioned machine.

This invention is therefore not limited to devices for closing the bottom flaps of box-blanks, but embraces also devices for closing similar top flaps of filled boxes.

In the accompanying drawings, consisting of five sheets, Figure 1 is a side elevation of my improved machine. Fig. 2 is a top plan view thereof. Fig. 3 is a fragmentary horizontal section, on an enlarged scale, in line 3 3, Fig. 1. Fig. 4 is a similar fragmentary section showing a subsequent position of the same parts. Fig. 5 is a transverse vertical section, on an enlarged scale, through the gumming mechanism in line 5 5, Fig. 1. Fig. 6 is a similar fragmentary section showing a subsequent position of the same parts. Fig. 7 is a fragmentary side elevation showing the bearing of the upper gumming-roller. Fig. 8 is a transverse vertical section, on an enlarged scale, of the folding mechanism in line 8 8, Fig. 1. Fig. 9 is a similar section showing a subsequent position of the parts. Fig. 10 is a transverse vertical section through the mechanism which completes the folding, on an enlarged scale, in line 10 10, Fig. 1. Fig. 11 is a transverse vertical section, on an enlarged scale, through the driving-wheel of the

endless feed-chain in line 11 11, Fig. 1. Fig. 12 is a horizontal section, on an enlarged scale, of one of the blank holders or carriers, showing the movable folding and clamping jaw of the holder closed against the same. Fig. 13 is a detached bottom plan view, on an enlarged scale, of the pivoted folding-fingers by which the side flaps of the bottom are folded down, the sliding folding-bar by which the rear flap is folded down, and the blade on the folding and clamping jaw of the holder by which the front flap is folded down. Fig. 14 is a similar view showing the same parts in a subsequent position. Fig. 15 is a fragmentary longitudinal section, on an enlarged scale, of the ejector mechanism in line 15 15, Fig. 2. Fig. 16 is a horizontal longitudinal section in line 16 16, Fig. 15. Fig. 17 is a transverse section in line 17 17, Fig. 15. Fig. 18 is a perspective view of one of the gripping-jaws of the ejector. Figs. 19, 20, and 21 are perspective views of one of the boxes or cartons inverted, showing the bottom flaps in different positions. Fig. 22 is a perspective view of a filled box having top flaps to be closed by pasting. Fig. 23 is a vertical section of one of the holders suitable for holding such a filled box in presenting the same to the gumming and folding mechanisms. Fig. 24 is a cross-section in line 24 24, Fig. 23, but showing the folding-jaw closed.

Like characters of reference refer to like parts in the several figures.

The main frame of the machine consists, essentially, of a longitudinal bed A, provided near each end with a pair of supporting-legs *a* and a lateral extension A' on its rear side.

The feed-chain, belt, or traveling carrier B passes around polygonal supporting-wheels *b* *b'*, arranged at opposite ends of the bed, and its upper horizontal portion runs over a horizontal guide or rail *b*², arranged lengthwise on top of the bed, while its lower horizontal portion runs over a horizontal guide or rail *b*³, arranged lengthwise below the bed and supported from the latter by hangers *b*⁴, as shown in Figs. 1, 2, 5, and 11. Each of the supporting-wheels is mounted on a transverse shaft *b*⁵, which is journaled in bearings on the under side of the bed. An intermittent forward movement is imparted to the feed-chain by a ratchet mechanism consisting of a pawl-arm C, hung loosely on the shaft of the rear chain-wheel *b'*, and a pawl *c*, sliding transversely in the pawl-arm and held yieldingly in the path of the ratchet-teeth *c'* on the side of the wheel *b'* by a spring *c*², as shown in Figs. 1 and 11. The pawl-arm is oscillated by a pitman *c*³, connected at one end to said arm and at its opposite end to a crank *c*⁴, arranged on the front end of a counter-shaft *c*⁵. The latter is journaled in bearings on the main frame and is driven at a reduced speed from the main driving-shaft *c*⁶ by a pinion *c*⁷, arranged on the main shaft and meshing with a gear-wheel *c*⁸ on the counter-shaft, as shown in Fig. 2. The main shaft is journaled in

bearings on the main frame and is coupled with or uncoupled from a driving-pulley *c*⁹, mounted thereon, by a clutch *c*¹⁰.

Each of the chain-links is provided with a carrier or holder D, suitable for receiving a box-blank in an inverted position—that is, with the bottom flaps at the outer end of the holder. Each holder consists of an open four-sided frame having the form and size of the body of the box or carton blank and a flat top or outer end *d*, against which the bottom flaps of the box are folded. The lower end of the holder is provided with a base or enlargement forming a shoulder *d'*, with which the ends of the cover-flaps of the box engage and which limit the downward movement of the box on the holder, so as to cause the bottom flaps to project upwardly beyond the upper flat end *d* of the holder, as shown in Figs. 5, 6, and 8. The holders may be secured to the links in any suitable way, the means shown in the drawings consisting of depending lips or flanges *d*², arranged on the base of the holders and secured to the inner side of the links by screws.

Each blank-holder is provided on its front side with a folding-jaw E, which is pivoted at its lower or inner end to the base of the holder and carries at its upper end a rearwardly-projecting folding-blade *e*, by which the front flap of the box is folded down. This folding-jaw is provided on opposite sides of its outer end with spring clasps or fingers *e'*, which when the jaw is closed against the holder engage against opposite sides of the blank-body carried by the holder, as shown in Figs. 11 and 12, and by frictional resistance prevent the jaw from swinging open. The opening movement of the jaw is limited by shoulders *e*², formed thereon adjacent to its pivot and adapted to engage with the base of the holder, as shown in Figs. 5, 6, and 8.

The box-blanks are placed upon the holders by the operator, while the holders pass along the front or receiving end of the bed with the four bottom flaps standing up straight, as shown in Figs. 1, 2, and 19. Each blank is then advanced to and stands still at the pasting or gumming mechanism, whereby paste or gum is applied to the front and rear flaps, and which is constructed as follows:

F represents a trough or receptacle containing the supply of paste or gum for gumming the bottom flaps and which is arranged on the front side of the machine and in front of the upper line of holders by a bracket *f*, arranged on the front part of the bed.

*f*¹ is a lower supply-roller which has its lower side immersed in the paste in the trough, and *f*² is an upper delivery-roller which takes the paste from the supply-roller. These paste-rollers are arranged lengthwise with reference to the feed-chain and are compelled to turn together by intermeshing gear-wheels *f*³, connected, respectively, with the shafts of the rollers. The latter are driven from the main shaft *c*⁶ by intermeshing bevel gear-

wheels f^4 f^5 , secured, respectively, to the front end of the main shaft, and a short shaft f^7 , journaled in a bearing in the adjacent leg of the frame, and a belt f^8 , passing around pulleys f^9 f^{10} , mounted on the shaft f^7 and the shaft of the paste-supply roller, respectively, as shown in Figs. 1, 2, and 5. The supply roller is journaled in stationary bearings on the bracket f . In order to permit of varying the amount of paste which the delivery-roller receives from the supply-roller, the delivery-roller is made adjustable toward and from the supply-roller. For this purpose each end of the shaft of the delivery-roller is journaled in a bearing f^{11} , which is adjustable vertically in a way f^{12} , arranged on the bracket f , by means of a spring f^{13} engaging with the under side and a set-screw f^{14} engaging with the upper side of the bearing f^{11} .

G represents the paste-brush or wiper, whereby the gum or paste is taken from the delivery-roller and applied to the front and rear bottom flaps of the box-blank. This brush moves transversely with reference to the feed-chain and is mounted on the front end of a supporting-bar g , which is moved back and forth and up and down above the blank. The body, with its bottom and cover flaps, is most clearly shown in Figs. 19, 20, and 21, in which 1 represents the four-sided body of the blank, and 2 the cover-flaps, which project downwardly, as the blank is shown in the inverted position in which it is operated upon by the machine. The four bottom flaps are the only flaps which are operated upon by the machine, and consist of two narrow opposing flaps 3, which are first folded down and which fold in the longitudinal direction of the feed-chain, and two wider opposing flaps 4 and 5, which fold crosswise of the feed-chain. The first-mentioned flaps 3 are first folded down and are called the "side flaps." The flap 4, which stands farthest from the paste-receptacle, is next folded down and is called the "rear flap," and the flap 5, which stands nearest the paste-receptacle, is last folded down and is called the "front flap."

The movement of the brush is as follows: In the foremost position of the paste-brush the same rests upon or sufficiently close to the upper side of the paste-delivery roller to take paste therefrom, as shown by dotted lines in Fig. 5. During the first portion of the backward movement of the brush the same rises, so as to pass over the front flap 5, which at this time stands in rear of the paste-rollers and vertically in line with the brush. When the brush has passed over the front flap, as shown in full lines, Fig. 5, and before it reaches the rear flap, as shown in Fig. 6, it drops to a point below the upper ends of said flaps, as shown in full lines in Fig. 6. The brush now completes its backward movement in this lowered position to a point in rear of the rear flap. (Shown in dotted lines in Fig.

6.) During this movement the brush applies paste to the front side of the rear flap along its edge. During the first portion of the subsequent forward movement the brush moves forward in this lowered position to a point in front of the front flap, whereby the brush applies paste successively to the rear side of the rear flap, which is the top side of that flap when folded down, and to the rear side of the front flap, which is the under side of that flap when folded down. The last portion of the forward movement of the brush carries the same again to the paste-delivery roller. By these movements the brush applies paste to both sides of the rear flap and the rear side of the front flap near the edges thereof. The mechanism whereby this movement is imparted to the brush is arranged in rear of the feed-chain and the blank-holders and is constructed as follows:

H represents an upright rock-lever whereby the paste-brush is moved back and forth and which is pivoted on the rear portion of the main frame. This lever has its upper arm pivotally connected to the rear end of the bar supporting the brush and is actuated by a grooved cam h , mounted on the counter-shaft and engaging with the lower arm of the rock-lever, as shown in Figs. 2, 5, and 8.

I represents a slotted shifting bar or guide whereby the paste-brush is raised and lowered. This guide is pivoted on its upper side near its front end by a horizontal pivot i to a standard i' on the bed, so that the guide swings in a vertical plane transversely to the movement of the feed-chain. The brush-bar is provided near its middle with a depending lug i^2 , engaging by a roller i^3 in the slot of the guide.

J represents a reciprocating or sliding cam which is arranged lengthwise below the shifting-guide and is provided on its upper side with a salient portion j and a horizontal receding portion j' , with which a depending bearing-lug i^4 on the rear portion of the guide is adapted to engage alternately. This cam is guided by bolts j^3 passing through horizontal slots j^4 in the cam and secured to a bracket j^5 on the main frame or in any other suitable way. The guide is yieldingly pressed downward with its bearing-lug against the cam J by a spring j^6 , connecting the guide with the bracket j^5 . The rear portion of the guide is steadied in its vertical movement by a pin j^7 , arranged on the guide and engaging in a curved slot j^8 in the bracket j^5 .

k represents a link or slotted rod pivoted at its rear end to the upper arm of the rock-lever H and engaging by its slot with a pin k' on the rear end of the sliding cams J .

During the first portion of the backward movement of the brush the salient portion of the sliding cam stands underneath the lug of the guide and holds the rear end of the latter in an elevated position, so that its slots rises rearwardly, as represented in Fig. 5. This causes the brush as it moves backwardly

to rise and to be lifted over the front flap of the blank. During this movement of the brush the link k travels idly backward along the pin k^2 of the cam, while the rock-lever H is moving the brush-supporting bar backwardly. When the brush has reached the position above the space between the front and rear flaps, as indicated by full lines in Fig. 5, the front end of the slot in the link k engages with the pin k^2 and causes the cam to move rearwardly with the rock-lever, thereby moving the salient portion of the cam rearwardly from underneath the lug of the guide and permitting the guide to drop with its bearing-lug i^4 upon the horizontal portion of the sliding cam, thus causing the brush to drop between the front and rear flaps. In this lowered position of the shifting guide its slot stands horizontally, which causes the brush-carrying bar and brush during the remainder of the backward stroke to move in a substantially horizontal direction. During this movement the brush applies paste to the front side of the rear flap. During the first portion of the subsequent forward stroke of the rock-lever the shifting link k slides forwardly idly and does not move the cam. This causes the shifting guide, supporting bar, and brush to remain in their lowered position until the brush has moved and applied paste to the rear sides of the rear and front flaps successively. After the brush has passed by the front flap the rear end of the slot in the link strikes the pin k^2 of the cam and shifts the same forwardly, thereby raising the rear end of the slotted guide, so that its slot stands in an inclined position preparatory to the next following backward movement of the brush. In order to prevent the rear flap from being displaced rearwardly when the paste-brush applies the paste to the front side thereof, a backing or retaining finger l is provided which supports the rear side of the rear flap, as shown in Figs. 1, 5, and 6. This supporting-finger is curved rearwardly at its front end, so as to direct the rear flaps of the blanks in front of the same as the blanks move rearwardly with the feed-chain. This finger is secured to the adjacent stationary part of the machine, as shown in Figs. 1 and 2. After the front and rear flaps of the blank have been gummed the blank is advanced one space by the propelling mechanism and presented to the folding mechanism, where the blank stands still until its flaps have been folded down upon the holder. This folding mechanism is arranged adjacent to the feed-chain and holders and at a distance in rear of the gumming mechanism equal to this distance between two blank-holders and is constructed as follows:

M, Figs. 2, 8, 9, 13, and 14, represents a longitudinally-reciprocating horizontal folding-bar, which is arranged transversely in rear of the rear flap of the blank when the latter is in line with the folding mechanism and which is provided with a tapered front end or edge

adapted to engage with the rear side of the rear flap. This bar is guided in horizontal ways m , arranged in the upper part of a standard m' on the main frame, and is reciprocated by an upright rock-lever m^2 , pivoted on said standard and having its upper arm engaging with the folding-bar, while its lower arm engages with a cam m^3 on the counter-shaft, as shown in Fig. 8. NN represent two horizontal folding-fingers whereby the side flaps of the bottom are folded down upon the holder. Each of these fingers is pivoted with its rear end to the guideway m on one side of the folding-bar and extends across the under side of the bar to the opposite side thereof. The two folding-fingers are fitted to cross each other, and their front ends are curved or hook-shaped and point toward each other, as shown in Figs. 2, 13, and 14. Each of these guide-fingers is provided with a cam-slot n , which receives a pin n' on the under side of the folding-bar. When the folding-bar and the folding-fingers are moved rearwardly or retracted to their fullest extent, they clear the path of blanks, as represented in Fig. 13. The cam-slots in the folding-fingers are so formed that upon moving the folding-bar forwardly the first part of this movement causes the fingers to swing forwardly and toward each other, whereby these fingers are engaged against the outer sides of the side flaps 3 of the bottom and fold the same down upon the top of the holder, as shown in Fig. 20. During the last portion of the forward movement of the folding-bar the latter engages against the rear side of the rear flap 4 and loosely folds the same forwardly and downwardly upon the side flaps 3, during which movement of the bar the fingers stand still in their foremost position and hold the side flaps down. After the side and rear flaps have been folded down the jaw E of the holder is swung forwardly or toward the holder, so that its blade e engages against the front flap and loosely folds the same down upon the side and rear flaps, as represented in Figs. 9 and 20. This movement of the folding-jaw is effected by a horizontal shifting rod o , which slides transversely in a guide in the lower portion of the bed and which is connected at its rear end with the lower arm of the rock-lever m^2 , while its front end is provided with an upwardly-projecting arm or finger o' , which engages with the front side of the folding-jaw. The movement of the several members of the folding mechanism is so timed that the side flaps are first folded down upon the holder, as shown in Fig. 20, after which the rear flap is folded loosely down upon the side flaps, and then the front flap is folded loosely down upon the side and rear flaps. After the flaps have been so folded the movement of the rock-lever m^2 is reversed, whereby the folding-fingers and bar are withdrawn rearwardly from the blank and the finger o' is disengaged from the folding-jaw of the holder. In order to prevent the folding-jaw of the holder from

moving backward or away from the holder and so cause the unfolding of the front flap when the shifting finger o' leaves the folding-jaw, a detent device is provided which holds the folding-jaw in its partially-closed position and which is constructed as follows:

P represents a catch which is arranged in front of the holders and capable of movement in the longitudinal direction of the feed-chain. This catch is provided at its front end with a transverse shoulder p , which stands in the path of the folding-jaw of the holder as the latter moves from the gumming to the folding mechanism. The catch slides horizontally in a guide p' , formed on a standard p^2 , rising from the front part of the bed. The catch is yieldingly held in its foremost position (shown in Fig. 4) by a spring p^3 , which connects the front end of the catch with an adjacent stationary part of the machine. As the blank-holder moves from the gumming to the folding mechanism its folding-jaw engages with the shoulder p of the catch P and moves the latter in the direction in which the holder moves to the position shown in Fig. 3, thereby straining the spring p^3 . When the folding-jaw is moved toward the holder for partially folding the front flap, the catch is moved in front of the folding-jaw by the spring p^3 , as shown in Fig. 4, thereby preventing the jaw from opening upon the withdrawal of the shifting finger o' .

After the flaps of the blank have been loosely folded down upon the holder the same is advanced another step and the rear portion of the blank is carried underneath a presser-roller Q, which presses down upon the rear flap and straightens the same out, so that it lies flat upon the side flaps and extends as far as possible under the front flap, as shown in Figs. 1, 2, and 10. This roller is pivoted on the upper end of a vertical supporting-bar q , which has a limited vertical movement on a standard q' , rising from the rear portion of the bed, by means of bolts q^2 , secured to the bar and passing through vertical slots q^3 in the standard. In the normal position of the roller the bolts of the bar rest upon the lower ends of the slots in the standard, in which position the lowermost part of the roller is below the top of the blank. As the blank is advanced from the preliminary-folding mechanism and passes with its rear flap under the presser-roller the latter is lifted, so that its weight exerts a pressure upon the rear flap for flattening the same. As the blank passes from underneath the roller the latter again drops. The presser-roller is preferably provided with an annular flange q^4 on its rear side, which engages against the rear side of the blank and compels the rear flap to straighten out forwardly and produces a square rear corner on the box. As the blank passes from the preliminary-folding mechanism to the presser-roller the folding-jaw of its holder leaves the catch P and passes along the rear edge of a horizontal retaining-guide q^5 , which

is formed lengthwise on the standard p^2 in front of the holder and retains the folding-jaw E in its partially-closed position, as shown in Fig. 3. As the holder carrying the blank advances from the presser-roller the folding-jaw of the holder engages with a cam q^6 , which moves the folding-jaw rearward to its fullest extent and folds the front flap of the blank firmly and closely down upon the rear flap and the side flaps, as shown in Figs. 3, 10, 11, and 21. This cam is arranged in front of the blank-holder and preferably made yielding by pivoting its front end to the standard p^2 adjacent to the rear end of the guide q^5 and supporting its rear end by a spring q^7 , which rises from the front part of the bed. When the folding of the gummed flaps is thus completed, the rear flap is secured to the side flaps by one line of gum or paste and to the front flap by two lines of paste. The folding-jaw of each holder is firmly held in its closed position by its clamping-fingers, which spring over and press the opposite sides of the blank against the holder, as shown in Fig. 12, so that the flaps are securely held down while they are drying. After the bottom flaps of the blank have been so gummed and folded each blank is carried step by step forwardly on its holder by the movement of the feed-chain. The holders containing the pasted blanks pass downwardly around the rear supporting-wheel, thence backwardly with the lower portion of the feed-chain, and finally upwardly around the front supporting-wheel. The feed-chain is made so long that the pasted flaps become thoroughly dry and set before the boxes reach the front end of the machine, at which they are removed from the holders. The ejecting mechanism, by which each box is removed from its holder, is arranged adjacent to the front supporting-wheel and is constructed as follows:

R represents a cam whereby each folding-jaw is opened or swung away from the box on its holder preparatory to removing the box from the holder. This cam is arranged adjacent to the front side of the front supporting-wheel and supported by an arm r , projecting from the adjacent front part of the bed. Each of the holders is provided on its upper or outer end with a stud or projection r' , which engages with the opening-cam as the holder passes upwardly around the front supporting-wheel, and the jaw is thereby swung forwardly, so as to release the box on the holder, as shown in Figs. 1 and 2.

S represents an ejector-carriage arranged in rear of the path of the blank-holders adjacent to the front supporting-wheel. This carriage is guided on a supporting-bar s , which projects from the rear part of the bed and has a reciprocating movement parallel with the box-holder from which the box is to be removed. The carriage is actuated by a rock-lever s' , with which it is connected by a connecting-rod s^2 . This lever is pivoted at its upper end to the rear portion of the bed and

is actuated by a cam s^3 , having a cam-groove which engages with a roller or pin s^4 on the rock-lever. The cam s^3 is mounted on the front end of a cam-shaft s^5 , journaled in bearings on the rear portion of the main frame. This shaft is driven from the counter-shaft c^5 by a chain belt s^6 , passing around sprocket-wheels s^7 s^8 , mounted, respectively, on the counter-shaft and the cam-shaft, as shown in Figs. 1, 2, and 8.

T T represent two grippers or jaws which are arranged one above the other and which are adapted to grasp opposite sides of the box on the holder and remove the same therefrom. The gripping-face of each jaw consists, preferably, of a rectangular body or plate t , having on its four sides outwardly-projecting toothed flanges t' , preferably formed out of one piece of sheet metal. Each of these gripping-faces is secured to a supporting-plate t^2 , which latter is pivoted on its outer side to the front end of an arm t^3 by a pivot arranged lengthwise of the holder from which the box is to be removed. The arms of both jaws are arranged transversely above and below the ejector-carriage and pivoted at their rear ends to the rear portion of the carriage, so that the jaws swing toward and from each other. The gripper-arms are guided on the front part of the ejector-carriage by a guide-plate t^4 , secured to the front part of the ejector-carriage and provided with transverse guide-slots t^5 , in which the gripper-arms are arranged. The gripper-jaws are constantly pressed toward each other by springs t^6 t^6 , which bear with their front ends against the front ends of the gripper-arms and are secured with their rear ends to a bracket t^7 , arranged on the rear side of the ejector-carriage.

V represents a cam-plate whereby the ejector-jaws are opened and closed. The cam-plate is mounted on the ejector-carriage and is capable of a limited longitudinal movement thereon independent of the carriage and parallel with the line of movement of the same. For this purpose the cam-plate is arranged between the front side of the ejector-carriage and the jaw guide-plate t^4 and is provided with a longitudinal slot v , which receives a rectangular boss v' on the front side of the carriage, as shown in Figs. 15, 16, and 17. The cam-plate is provided on its upper and lower sides with projections v^2 , having inclines v^3 on their inner sides which engage with the inner sides of the gripper-carrying arms. Upon moving the carriage outwardly with reference to the cam-plate the inclines thereof engage with the gripper-arms and spread the same until the top or flat outer sides of the cam-plate projections engage with the gripper-arms, in which position of the cam-plate the gripper-arms are retained in a spread position, as shown in Fig. 15. Upon moving the carriage inwardly with reference to the cam-plate the projections of the same

are moved from underneath the gripper-arms and the latter are moved toward each other by the springs t^6 .

V V' represent inner and outer stops whereby the cam-plate is shifted with reference to the ejector-carriage for moving the grippers toward and from each other and which are arranged in the inner and outer end of the path of the cam-plate. While the feed-chain is moving forward with the blank-holders the ejector-carriage is in its outermost position and at rest, in which position the grippers are spread, as shown in Figs. 15 and 17. At the end of each intermittent forward movement of the feed-chain a holder carrying a box stands still in line with the ejector-carriage. The latter is now moved inwardly by the cam s^3 , whereby its jaws in a spread position are carried above and below the box in the holder. During the last portion of the inward movement of the carriage the cam-plate strikes the inner stop V and is arrested thereby. This causes the carriage, which now moves forward independently of the cam-plate to the end of its inward stroke, to move its gripper-arms from the top of the cam projections inwardly. This causes the springs to press the gripper-arms toward each other and engage the grippers against the upper and lower sides of the box on the holder. The ejector-carriage now moves outwardly, with its jaws grasping the box, whereby the latter is stripped from the holder. During the last portion of the outward movement of the ejector-carriage the outer end of the cam-plate moving therewith strikes the outer stop V', whereby the outward movement of the cam-plate is arrested. The ejector-carriage continues to move outwardly to the end of its outward stroke independently of the cam-plate, which causes its jaw-arms to move along the inclines of the cam-plate to the top thereof, thereby spreading the jaws and disengaging the same from the box after the latter has been removed from the holder. The outer stop is rigidly secured to the guide-arm, upon which the ejector-carriage slides.

In starting the machine it is desirable that the gripper-jaws should be held open until the holder which carries the first box has reached the ejector in order to avoid wearing the sides of the holders by the scraping of the grippers along the same, which would occur if the grippers closed against the holders before they carry any boxes. For this purpose the inner stop V is removably supported in a loop v , arranged on the adjacent part of the bed. Upon removing this stop the cam-plate encounters no obstruction at the end of its inward movement, but moves inwardly with the ejector-carriage to the end of the stroke, which causes the cam-plate to retain the gripper-arms open and so prevents them from grasping the empty holder during the subsequent outward stroke of the carriage.

When the first holder carrying a box arrives near the ejector, the inner stop is inserted and the ejector thereby made operative.

W represents an ejector or clearing-finger whereby the box is discharged forwardly from between the ejector-grippers. This finger is pivoted with its outer end to the guide-bars of the carriage, so that its inner end swings between the grippers laterally with reference to the movement of the ejector-carriage. The ejector-finger is yieldingly held in its rearward or retracted position by a spring w , bearing with its ends against the front side of the ejector-finger, and an adjusting screw-nut w' , arranged upon a rod w^2 , which is connected with the guide-bar.

w^3 is a cam face or incline formed on the outer side of the guide-plate t^4 and adapted to engage with a similar cam face or incline w^4 on the ejector-finger. During the inward movement of the ejector-carriage and connecting parts the ejector-finger is moved rearwardly by the spring w^5 , so as to clear the path of the box, as shown by dotted lines in Fig. 16. During the last portion of the subsequent outward movement of the carriage the grippers remove the box from the holder and carry it in front of the ejector-finger. The cam-face w^3 of the carriage engages with that of the ejector-finger and quickly moves the finger laterally and forwardly into the position shown in full lines in Fig. 16, whereby the box, which at this time has been released from the grippers, is ejected forwardly from between the grippers, thereby clearing the latter preparatory to the next inward movement. When the machine is fully in operation, the gumming, folding, and ejecting mechanisms each operates upon a separate box after each intermittent forward movement of the feed-chain and holders, so that the several operations are performed simultaneously on different boxes.

When the top flaps of the boxes are also so constructed that they can be closed by pasting, a similar machine is used for closing the tops of the boxes after they are filled. A box constructed in that manner is shown in Fig. 22, in which 3' represents the side flaps of the top, 4' the rear flap, and 5' the front flap, which flaps are like the corresponding bottom flaps. In the machine designed for closing such boxes after they are filled the holders X, Figs. 23 and 24, are hollow four-sided receptacles of the proper size to receive the filled box and hold it rather loosely, with the top flaps projecting upwardly in the same manner in which the bottom flaps project from the holders of the first-described machine. In all other respects the machine is in its general organization and in the construction of the gumming and folding mechanism the same as the first-described machine. The spring-clasps e' of the folding-jaw E engage in the machine for closing the tops against the sides of the box-holders instead of against

the sides of the box-blanks and so hold the jaw from swinging open until released by the cam R. This cam is in this top-closing machine arranged lower down than it is shown in Fig. 1, so that the folding-jaw E is released when the holder is still fully in its inverted position on the under side of the polygonal wheel b . When the jaw is swung away in that position of the holder, the box is released and drops out of the holder by its own weight, an additional ejecting device being usually not required.

I claim as my invention—

1. The combination with the feed mechanism provided with holders for carrying the boxes or blanks and presenting the same to the pasting and folding mechanisms, of a pasting mechanism whereby paste is applied to projecting flaps of the box or blank, a stationary folding mechanism arranged beyond the paste mechanism in the direction in which the feed mechanism moves and containing folders whereby the side flaps and the rear flap are folded down, and traveling final folders whereby the final flaps are folded down, one of which folders is arranged with each blank-holder and travels with the same, substantially as set forth.

2. The combination with the feed mechanism provided with holders for carrying the boxes or blanks and presenting the same to the pasting and folding mechanisms, of a pasting mechanism whereby the paste is applied to the projecting flaps of the box or blank, a stationary folding mechanism containing fingers for folding the side flaps down, a sliding folder for folding the rear flap upon the side flaps, mechanism whereby said folder is actuated after said fingers have been actuated, traveling folders for folding the final flap down, one of which folders is arranged with each blank-holder and travels with the same, and mechanism whereby each traveling folder is swung against the final flap after the rear flap has been folded down and before such flap is released by its folder, substantially as set forth.

3. The combination with the feed mechanism provided with projecting holders for carrying the boxes or blanks and presenting the same to the pasting and folding mechanisms, of a paste mechanism which applies the paste to projecting flaps of the box or blank, a stationary folding mechanism arranged beyond the paste mechanism in the direction in which the feed mechanism moves and on one side of the path of the feed mechanism and its holders, such folding mechanism containing folders whereby the side flaps and the rear flap are folded down, and traveling folding-jaws arranged on the opposite side of said holders, pivoted at their lower ends to swing toward and from the holders and provided at their free upper ends with folding-blades adapted to project across the holders, substantially as set forth.

4. The combination with a traveling holder adapted to carry a box-blank or box, of a folding-jaw pivoted at its lower end to the base of the holder to swing toward and from the same and provided at its upper end with a folding-blade which projects across the top of the holder when the jaw is closed against the holder, substantially as set forth.
5. The combination with the feed mechanism provided with a holder adapted to carry a box-blank or box, of a folding-jaw pivoted at its lower end to the base of the holder and provided at its free end with a folding-blade and at its sides with clamping-fingers adapted to bear against opposite sides of the blank or box on the holder, substantially as set forth.
6. The combination with the feed mechanism provided with holders adapted to carry the box-blanks or boxes with the end flaps projecting therefrom and the paste-supply devices, of a reciprocating paste wiper or brush, and guide devices whereby said wiper or brush is raised while moving from the paste-supply devices to clear the front flap and lowered before reaching the rear flap to apply the paste first to the latter, substantially as set forth.
7. The combination with the feed mechanism provided with holders for carrying the box-blanks or boxes with their end flaps projecting therefrom, of a reciprocating paste wiper or brush traveling toward and from the paste-supply devices and across the path of said holders, and guide devices whereby the wiper or brush is raised while moving from the paste-supply devices to clear the front flap and lowered before reaching the rear flap, to apply the paste first to the front side of the latter, and is moved in its lowered position toward the paste-receptacle to apply the paste next to the rear side of the rear flap and then to the rear side of the front flap, substantially as set forth.
8. The combination with the paste-supply devices, of a wiper or brush, means whereby the same is moved toward and from the paste-supply devices, a slotted shifting guide whereby said wiper or brush is first raised and then lowered while moving from the paste-supply devices, and a cam whereby said guide is shifted, substantially as set forth.
9. The combination with paste-supply devices, of a supporting-bar provided with a paste wiper or brush, a rock-lever which is connected with the supporting-bar and whereby the wiper or brush is moved toward and from the paste-supply devices, a shifting guide pivoted near its front end and provided with a slot which receives a projection on said supporting-bar, a sliding cam engaging with the rear portion of said guide, and a link loosely connecting the cam with said rock-lever, substantially as set forth.
10. The combination with the paste-supply devices, the feed mechanism provided with holders for carrying the box-blanks or boxes, and a paste wiper or brush traveling toward and from the paste-supply devices and across the path of said holders, of a backing-finger arranged in rear of said path and adapted to support the rear flap against the rearward pressure of said wiper or brush, substantially as set forth.
11. The combination with the intermittently-moving feed mechanism provided with holders adapted to carry the box-blanks or boxes, of horizontal pivoted fingers which fold the side flaps and are provided with cam-slots, and a reciprocating folding-bar which folds the rear flap and which is provided with pins engaging in the slots in the fingers for actuating the same, substantially as set forth.
12. The combination with the intermittently-moving feed mechanism provided with holders adapted to carry the box-blanks or boxes, of horizontal pivoted folding-fingers for folding the side flaps, a reciprocating folding-bar for folding the rear flap, which bar is connected with said fingers and operates the same, folding-jaws mounted on the feed mechanism and moving therewith, and an actuating-finger whereby the folding-jaw of the holder which is in line with the folding mechanism is closed against the holder for folding the front flap, substantially as set forth.
13. The combination with the intermittently-moving feed mechanism provided with holders adapted to carry the box-blanks or boxes, of horizontal pivoted fingers which fold the side flaps and are provided with cam-slots, a reciprocating folding-bar which folds the rear flap and which is provided with pins engaging in the slots in the fingers for actuating the same, folding-jaws mounted on the feed mechanism and adapted to fold the front flaps, an actuating-finger adapted to engage the jaw which is in line with the folding mechanism, and a rock-lever connected with said folding-bar and actuating-finger, substantially as set forth.
14. The combination with the feed mechanism provided with a holder adapted to carry a box-blank or box and having a movable folding-jaw, of a catch arranged in the path of the movement of said jaw and movable in the direction in which said jaw moves with the feed mechanism, and an actuating device whereby said jaw is moved toward the holder and released from said catch, substantially as set forth.
15. The combination with the feed mechanism provided with a holder adapted to carry a box-blank or box and having a movable folding-jaw, of a catch arranged in the path of the movement of said jaw and movable in the direction in which said jaw moves with the feed mechanism, and an actuating device whereby said jaw is moved toward the holder and released from said catch, and a spring whereby the catch is returned after said jaw has been released therefrom, substantially as set forth.
16. The combination with the feed mechanism provided with holders for carrying the

boxes or blanks and presenting the same to the pasting and folding mechanisms, of a pasting mechanism whereby paste is applied to projecting flaps of the box or blank, folding devices whereby the side flaps and the rear flap are successively folded down, a final folder whereby the front or final flap is folded down upon the rear flap, a pressure device which bears upon the rear flap after the same has been folded down and which clears the front flap, and means whereby the final folder is tightened upon the final flap after the rear flap has been acted upon by said pressure device, substantially as set forth.

17. The combination with the feed mechanism provided with holders for carrying the boxes or blanks and presenting the same to the pasting and folding mechanisms, of a pasting mechanism whereby paste is applied to projecting flaps of the box or blank, folding devices whereby the side flaps and the rear flap are successively folded down, traveling final folders which move with the holders and whereby each final flap is folded down upon the rear flap, a pressure device which bears upon the rear flap after the same has been folded down, and means whereby each final folder is tightened upon the final flap after the rear flap has been acted upon by said pressure device, substantially as set forth.

18. The combination with the feed mechanism provided with holders for carrying the boxes or blanks and presenting the same to the pasting and folding mechanisms, of a pasting mechanism whereby paste is applied to projecting flaps of the box or blank, a stationary folding mechanism arranged beyond the paste mechanism in the direction in which the feed mechanism moves and containing folders whereby the side flaps and the rear flap are successively folded down, traveling final folders which move with the feed mechanism and holders and whereby each final flap is folded down upon the rear flap, and a pressure device which is arranged beyond said folding mechanism and which bears upon the rear flap after the box or blank has passed beyond said folding mechanism, substantially as set forth.

19. The combination with the feed mechanism provided with holders adapted to carry the box-blanks or boxes, of folding devices whereby the side flaps and the rear flap are successively folded down, a folder whereby the front flap is folded down upon the rear flap, and a flanged pressure-roller which bears upon the rear flap after the same has been folded down, substantially as set forth.

20. The combination with the feed mechanism provided with a holder adapted to carry a box-blank or box, of folding devices whereby the side flaps and the rear flap are successively folded down, a folding-jaw connected with said holder for folding down the front flap, an actuating device whereby said jaw is closed, a pressure device bearing upon the rear flap after the same has been folded

down, and a final folding-cam whereby said jaw is tightly closed down after the rear flap has been pressed down by said pressure device, substantially as set forth.

21. The combination with the feed mechanism provided with a holder adapted to carry a box-blank or box, of a folding-jaw pivoted at its lower end to the base of the holder and provided at its free end with a folding-blade, and a releasing-cam which swings the free end of the jaw away from the holder, substantially as set forth.

22. The combination with the feed mechanism provided with a holder adapted to carry a box-blank or box, of a folding-jaw pivoted at its lower end to the base of the holder and provided at its free end with a folding-blade and at its sides with yielding clamping-fingers adapted to bear against the sides of the blank or box on the holder, and a releasing-cam against which said jaw engages for withdrawing the free end of the jaw from the holder preparatory to removing the box from the holder, substantially as set forth.

23. The combination with the feed mechanism provided with a holder upon which the box is carried, of a reciprocating ejector movable toward and from the holder and having gripping-jaws which are closed upon the box on the holder for removing the box therefrom and opened for discharging the box, substantially as set forth.

24. The combination with the feed mechanism provided with a holder upon which the box is carried, of a reciprocating ejector movable toward and from said holder and having gripping-jaws which are closed upon the box on the holder for removing the box therefrom and opened for discharging the box, and an ejector-finger whereby the box is removed from the jaws when the latter are opened, substantially as set forth.

25. The combination with the feed mechanism provided with a holder upon which the box is carried, of a reciprocating ejector-carriage movable toward and from said holder, gripping-jaws attached to said carriage, a cam-plate by which said jaws are opened and closed, and stops whereby the movement of said cam-plate is arrested for effecting the opening and closing of the jaws, substantially as set forth.

26. The combination with the feed mechanism provided with a holder upon which the box is carried, of a reciprocating ejector-carriage movable toward and from the holder and having gripping-jaws which are closed upon the box on the holder for removing the same therefrom and opened for discharging the box, an ejector-finger arranged between the gripping-jaws, a spring whereby the ejector-finger is yieldingly held out of the path of the box, and an incline arranged on the ejector-carriage adapted to engage with an incline on the ejector-finger for moving the latter across the path of the gripping-jaws and discharging the box therefrom, substantially as set forth.

27. The combination with the feed mechanism provided with a holder upon which the box is carried, of a reciprocating ejector-carriage movable toward and from said holder, arms pivoted to said carriage and provided with gripping-jaws, a cam-plate guided on the carriage and provided with inclines adapted to engage with said arms for opening and closing said jaws, springs whereby said arms are held in engagement with said cam-plate, and stops arranged at the inner and outer ends of the path of the cam-plate for arresting the movement thereof and effecting the opening and closing of said jaws, substantially as set forth.

28. The combination with the feed mechanism provided with a holder upon which the box is carried, a reciprocating ejector-carriage movable toward and from said holder, a cam-plate moving with said carriage and capable of limited movement with reference thereto, gripping-jaws attached to said carriage and moved by said cam-plate, and a removable stop which can be placed in the path of the said cam-plate for arresting its movement while the carriage moves on or can be removed for allowing said cam-plate to move with said carriage, substantially as set forth.

29. The combination with the feed mechanism provided with a holder upon which the box is carried, of a reciprocating ejector-carriage movable toward and from said holder, arms pivoted to said holder and having gripping-jaws which are closed upon the box on the holder, said jaws being provided with hollow four-sided gripping-faces having toothed edges, and means whereby said jaws are opened and closed, substantially as set forth.

30. The combination with the stationary frame and the traveling carrier provided with a holder for carrying the box or blank, of a stationary folding mechanism mounted on said frame and comprising two side-folders whereby the side flaps are folded down upon the holder, and a folder whereby one of the end flaps is folded down, and a traveling folder whereby the final flap is folded down and which is arranged opposite the holder on the traveling carrier, substantially as set forth.

31. The combination with the stationary frame and the traveling carrier provided with a plurality of holders for carrying the boxes or blanks, of a stationary folding mechanism which is mounted on the stationary frame and which acts upon the flaps, excepting the

final flap, of each box or blank as it is presented to the stationary folding mechanism, and a traveling folder which is arranged opposite each holder on the traveling carrier and which folds the final flap and holds the same down while the box or blank is carried on the carrier, substantially as set forth.

32. The combination with the stationary frame and the traveling carrier provided with a plurality of holders for carrying the boxes or blanks, of a stationary folding mechanism mounted on said frame and comprising fingers for folding the side flaps down, and a sliding folder for folding the rear flap upon the side flaps, and traveling final folders moving with said carrier and pivoted at their lower ends opposite said holders to swing toward and from the same, substantially as set forth.

33. A box-folding machine embracing a traveling carrier, and means for folding the last flap of the box and retaining it in position comprising a form or block mounted on said carrier, a pivoted retaining plate or arm and means engaging said plate in a manner to hold the same either in its raised or lowered position, substantially as set forth.

34. A box-folding machine embracing a traveling carrier, a form or block mounted on said carrier, a pivoted flap-holding plate or arm, means for automatically raising said plate from or lowering it upon the form and means acting to hold said plate either in its raised or lowered position, substantially as set forth.

35. A box-folding machine comprising a main frame provided in its opposite ends with rotative pulleys, a carrier trained over said pulleys and adapted to travel in ways mounted in said frame between the pulleys, a box-blank form mounted on said carrier, means for simultaneously folding the flaps connected with two opposite side walls together and upon the form, means for folding one of the intermediate flaps upon said first-mentioned flaps, and means for folding a fourth intermediate flap upon the form, to the under side of which paste has been applied and for holding said flap in place until the paste thereon becomes set, substantially as set forth.

Witness my hand this 9th day of November, 1898.

CHARLES H. BROOKS.

Witnesses:

M. D. CLARK,
HOWARD U. LYON.