



(12) **DEMANDE DE BREVET CANADIEN
CANADIAN PATENT APPLICATION**

(13) **A1**

(86) Date de dépôt PCT/PCT Filing Date: 2017/04/18
 (87) Date publication PCT/PCT Publication Date: 2017/10/26
 (85) Entrée phase nationale/National Entry: 2018/09/26
 (86) N° demande PCT/PCT Application No.: US 2017/028188
 (87) N° publication PCT/PCT Publication No.: 2017/184639
 (30) Priorités/Priorities: 2016/04/18 (US62/324,095);
 2016/07/22 (US62/365,824); 2017/01/05 (US62/442,895)

(51) Cl.Int./Int.Cl. *A01C 15/00* (2006.01),
A01B 15/18 (2006.01), *A01B 49/06* (2006.01),
A01C 5/04 (2006.01), *A01C 5/06* (2006.01),
A01G 25/09 (2006.01)
 (71) Demandeur/Applicant:
 PRECISION PLANTING LLC, US
 (72) Inventeurs/Inventors:
 LEHMAN, TRACY, US;
 STOLLER, JASON, US;
 RADTKE, IAN, US;
 WILDERMUTH, PAUL, US
 (74) Agent: MLT AIKINS LLP

(54) Titre : OUTILS ET UNITES D'APPLICATION AYANT AU MOINS UN ELEMENT D'APPLICATION POUR LA REALISATION D'APPLICATIONS PAR RAPPORT A DES PLANTES AGRICOLES DE CHAMPS AGRICOLES
 (54) Title: IMPLEMENTS AND APPLICATION UNITS HAVING AT LEAST ONE APPLICATION MEMBER FOR PLACEMENT OF APPLICATIONS WITH RESPECT TO AGRICULTURAL PLANTS OF AGRICULTURAL FIELDS

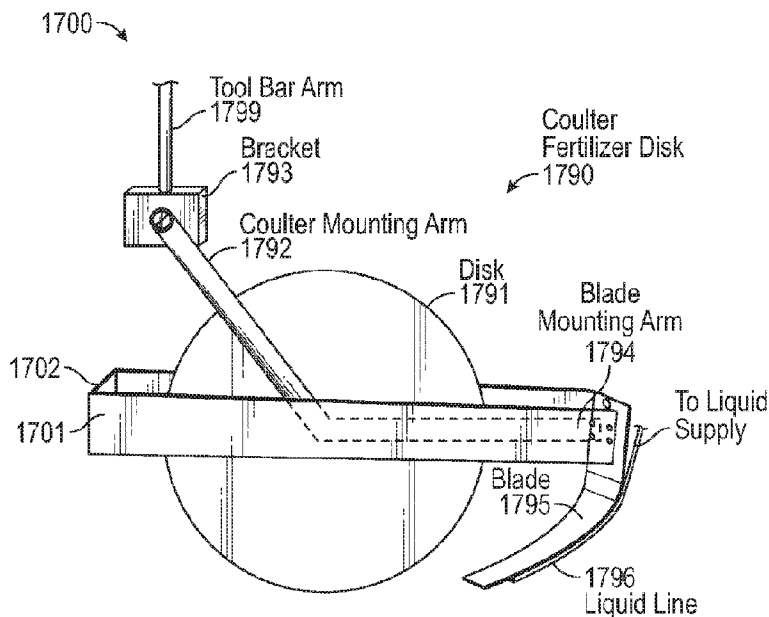

FIG. 17A

(57) **Abrégé/Abstract:**

Described herein are implements and applicators for placement of fluid applications with respect to agricultural plants of agricultural fields. In one embodiment, a fluid applicator for applying fluids to plants in rows in a field includes a frame, a coultter connected to the frame and disposed to open a trench between the rows of plants, and at least one application member connected to the frame or to the coultter and disposed to apply fluid to a rhizosphere of the plants.

(12) INTERNATIONAL APPLICATION PUBLISHED UNDER THE PATENT COOPERATION TREATY (PCT)

(19) World Intellectual Property
Organization
International Bureau



(10) International Publication Number
WO 2017/184639 A1

(43) International Publication Date
26 October 2017 (26.10.2017)

(51) International Patent Classification:

A01B 15/18 (2006.01) A01G 25/09 (2006.01)
A01C 5/04 (2006.01)

Road 700N, Eureka, Illinois 61530 (US). **RADTKE, Ian**;
281 Circle Shore Drive, Washington, Illinois 61571 (US).
WILDERMUTH, Paul; 9146 Lay Road, Tremont, Illinois
61568 (US).

(21) International Application Number:

PCT/US2017/028188

(74) Agent: **SCHWEIGERT, Jeremy A.** et al.; **BLAKELY, SOKOLOFF, TAYLOR & ZAFMAN**, 1279 Oakmead Parkway, Sunnyvale, California 94085 (US).

(22) International Filing Date:

18 April 2017 (18.04.2017)

(25) Filing Language:

English

(26) Publication Language:

English

(30) Priority Data:

62/324,095	18 April 2016 (18.04.2016)	US
62/365,824	22 July 2016 (22.07.2016)	US
62/442,895	05 January 2017 (05.01.2017)	US

(81) Designated States (unless otherwise indicated, for every kind of national protection available): AE, AG, AL, AM, AO, AT, AU, AZ, BA, BB, BG, BH, BN, BR, BW, BY, BZ, CA, CH, CL, CN, CO, CR, CU, CZ, DE, DJ, DK, DM, DO, DZ, EC, EE, EG, ES, FI, GB, GD, GE, GH, GM, GT, HN, HR, HU, ID, IL, IN, IR, IS, JP, KE, KG, KH, KN, KP, KR, KW, KZ, LA, LC, LK, LR, LS, LU, LY, MA, MD, ME, MG, MK, MN, MW, MX, MY, MZ, NA, NG, NI, NO, NZ, OM, PA, PE, PG, PH, PL, PT, QA, RO, RS, RU, RW, SA, SC, SD, SE, SG, SK, SL, SM, ST, SV, SY, TH, TJ, TM, TN, TR, TT, TZ, UA, UG, US, UZ, VC, VN, ZA, ZM, ZW.

(71) Applicant: **PRECISION PLANTING LLC** [US/US];
23207 Townline Road, Tremont, Illinois 61568 (US).

(72) Inventors: **LEHMAN, Tracy**; 730 State Route 117, Eureka, Illinois 61530 (US). **STOLLER, Jason**; 1161 County

(54) Title: IMPLEMENTS AND APPLICATION UNITS HAVING AT LEAST ONE APPLICATION MEMBER FOR PLACEMENT OF APPLICATIONS WITH RESPECT TO AGRICULTURAL PLANTS OF AGRICULTURAL FIELDS



WO 2017/184639 A1

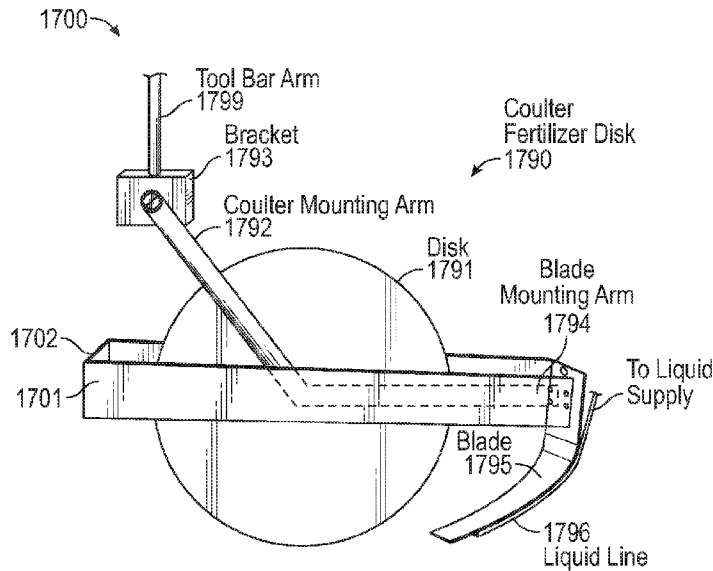

FIG. 17A

(57) Abstract: Described herein are implements and applicators for placement of fluid applications with respect to agricultural plants of agricultural fields. In one embodiment, a fluid applicator for applying fluids to plants in rows in a field includes a frame, a coultter connected to the frame and disposed to open a trench between the rows of plants, and at least one application member connected to the frame or to the coultter and disposed to apply fluid to a rhizosphere of the plants.

WO 2017/184639 A1 

(84) Designated States (*unless otherwise indicated, for every kind of regional protection available*): ARIPO (BW, GH, GM, KE, LR, LS, MW, MZ, NA, RW, SD, SL, ST, SZ, TZ, UG, ZM, ZW), Eurasian (AM, AZ, BY, KG, KZ, RU, TJ, TM), European (AL, AT, BE, BG, CH, CY, CZ, DE, DK, EE, ES, FI, FR, GB, GR, HR, HU, IE, IS, IT, LT, LU, LV, MC, MK, MT, NL, NO, PL, PT, RO, RS, SE, SI, SK, SM, TR), OAPI (BF, BJ, CF, CG, CI, CM, GA, GN, GQ, GW, KM, ML, MR, NE, SN, TD, TG).

Declarations under Rule 4.17:

— *of inventorship (Rule 4.17(iv))*

Published:

— *with international search report (Art. 21(3))*
— *before the expiration of the time limit for amending the claims and to be republished in the event of receipt of amendments (Rule 48.2(h))*

**IMPLEMENTS AND APPLICATION UNITS HAVING AT LEAST ONE
APPLICATION MEMBER FOR PLACEMENT OF APPLICATIONS WITH RESPECT
TO AGRICULTURAL PLANTS OF AGRICULTURAL FIELDS**

RELATED APPLICATIONS

5 This application claims the benefit of U.S. Provisional Application No.
62/324,095, filed on April 18, 2016 entitled: IMPLEMENTS AND APPLICATION UNITS
FOR PLACEMENT OF APPLICATIONS WITH RESPECT TO AGRICULTURAL
PLANTS OF AGRICULTURAL FIELDS; U.S. Provisional Application No. 62/365,824,
filed on July 22, 2016 entitled: IMPLEMENTS AND APPLICATION UNITS FOR
10 PLACEMENT OF APPLICATIONS WITH RESPECT TO AGRICULTURAL PLANTS OF
AGRICULTURAL FIELDS; U.S. Provisional Application No. 62/442,895, filed on
January 5, 2017 entitled: IMPLEMENTS AND APPLICATION UNITS FOR
PLACEMENT OF APPLICATIONS WITH RESPECT TO AGRICULTURAL PLANTS OF
AGRICULTURAL FIELDS, the entire contents of which are hereby incorporated by
15 reference.

TECHNICAL FIELD

Embodiments of the present disclosure relate to implements, application units,
and fluid applicators having at least one application member for placement of fluid
20 applications with respect to agricultural plants of agricultural fields.

BACKGROUND

Planters are used for planting seeds of crops (e.g., corn, soybeans) in a field.
Planters may also be used for applying a fluid application (e.g., fertilizers, chemicals) to
the soil or crops. Other fluid applicators include sprayers and sidedress bars. Applying
25 the fluid application between rows can be challenging in terms of controlling this
application for the different row units.

BRIEF DESCRIPTION OF THE DRAWINGS

The present disclosure is illustrated by way of example, and not by way of
30 limitation, in the figures of the accompanying drawings and in which:

Figure 1 shows an example of a system for performing agricultural operations of
agricultural fields including operations of an implement having application units in
accordance with one embodiment.

Figure 2 illustrates an architecture of an implement 200 for delivering applications (e.g., fluid applications, fluid mixture applications) to agricultural fields in accordance with one embodiment.

5 Figure 3A illustrates a rear view of an application unit 300 (e.g., a fluid application unit) 300 for applying an application to plants P-1, P-2 (e.g., corn plants, soy bean plants, etc.) in accordance with one embodiment.

Figure 3B illustrates a top view of an application unit 300 (e.g., a fluid application unit) 300 for applying an application to plants P-1, P-2 (e.g., corn plants, soy bean plants, etc.) in accordance with one embodiment.

10 Figure 4 illustrates an embodiment (rear view 402) of an application unit 400 (e.g., fluid application unit 400).

Figure 5 illustrates an embodiment (rear view 502) of an application unit 500 (e.g., fluid application unit 500).

Figures 6A and 6B illustrate another embodiment of a fluid application unit 600.

15 Figure 7 illustrates another embodiment of a fluid application unit 700.

Figure 8A illustrates an embodiment of a fluid application unit 800.

Figure 8B illustrates an embodiment of a fluid application unit 850.

20 Figure 9A illustrates a top view 902 of an application unit 900 (e.g., a fluid application unit) 900 for applying an application to plants P-9, P-10 (e.g., corn plants, soy bean plants, etc.) in accordance with one embodiment.

Figure 9B illustrates a top view 904 in which the linkage members 920a, 920b are biased in a non-centered position between rows of plants in accordance with one embodiment.

25 Figure 9C illustrates a side view 940 of the application unit 900 in accordance with one embodiment.

Figure 9D illustrates a top view 952 of application units 950, 980 (e.g., a fluid application unit) for applying an application to plants P-9, P-10 (e.g., corn plants, soy bean plants, etc.) in accordance with one embodiment.

30 Figure 10 illustrates a side view of an application unit 1000 in accordance with one embodiment.

Figure 11 illustrates a rear view 1102 of an application unit 1100 in accordance with one embodiment.

Figure 12 shows an example of a system 1200 that includes a machine 1202 (e.g., tractor, combine harvester, etc.) and an implement 1240 (e.g., planter, cultivator,

plough, sprayer, spreader, irrigation implement, etc.) in accordance with one embodiment.

Figure 13A (side view) illustrates an embodiment of a fluid application unit 1300.

Figure 13B (top view) illustrates an embodiment of a liquid application unit 1350
5 having multiple trench forming members (e.g., knives) and fluid outlets.

Figure 14 illustrates an adjustable bracket 1400 for coupling any of the frames described herein to a bar 10 in accordance with one embodiment.

Figure 15A illustrates an isometric view of an application unit 1500 in accordance with one embodiment.

10 Figure 15B illustrates an isometric view of a fluid biasing system for use with application unit 1532 in accordance with one embodiment.

Figure 16 illustrates an isometric view of an application unit 1600 positioned in proximity to rows of plants in accordance with one embodiment.

15 Figure 17A illustrates an isometric view of an application unit 1700 in accordance with one embodiment.

Figure 17B illustrates an isometric view of an application unit 1750 in accordance with one embodiment.

Figure 17C illustrates a side view of an application unit 1752 in accordance with one embodiment.

20 Figure 17D illustrates an isometric view of an application unit 1780 in accordance with another embodiment.

Figure 18A illustrates an isometric view of a solenoid actuated system for use with application unit 1700 in accordance with one embodiment.

25 Figure 18B illustrates an isometric view of a motor actuated system for use with application unit 1700 in accordance with one embodiment.

Figure 19A illustrates an isometric view of a linkage system actuated with a solenoid for use with application unit 1700 in accordance with one embodiment.

Figure 19B illustrates an isometric view of a linkage system actuated with a motor for use with application unit 1700 in accordance with one embodiment.

30 Figure 19C illustrates an isometric view of a linkage system actuated with a ground contacting arm for use with application unit 1700 in accordance with one embodiment.

Figure 20A is a side elevation view of a closer on a coulter wheel according to one embodiment.

Figure 20B is a rear view of the closer of Figure 20A according to one embodiment in which the top and bottom of the arms are equidistant to the axis through the trench and the front and back of the arms are equidistant to the axis through the trench.

5 Figure 20C is a rear view of the closer of Figure 20A according to one embodiment in which the bottom of the arms are closer to the axis through the trench than the top of the arms.

10 Figure 20D is a rear view of the closer of Figure 20A according to one embodiment in which the back of the arms are closer to the axis through the trench than the front of the arms.

Figure 20E is a rear view of the closer of Figure 20A according to one embodiment in which the bottom of the arms are closer to the axis through the trench than the top of the arms and the back of the arms are closer to the axis through the trench than the front of the arms.

15 Figure 20F is a side view of the closer of Figure 20B according to one embodiment in which the bottom of the arm is at least partially disposed behind the top of the arm in a direction of travel.

Figure 21A is a side elevation view of an alternative closer disposed on a blade according to one embodiment.

20 Figure 21B is a rear elevation view of the blade and closer of Figure 21A.

Figure 22A is a side elevation view of an alternative nozzle having a biasing ski according to one embodiment.

Figure 22B is a bottom view of the nozzle of Figure 22A with the biasing ski removed for clarity.

25 Figure 23 is a top view of a flexible member having a reinforcement disposed thereon according to one embodiment.

Figure 24A is a side elevation view of a cradle disposed on a bracket according to one embodiment.

Figure 24B is a rear elevation view of the cradle of Figure 24A.

30 Figure 25 is an alternative embodiment of an application unit 3200 according to one embodiment.

Figure 26 is an alternative embodiment for a spring disposed over a flexible member.

Figure 27A illustrates a side elevation view of an application unit 2700 according to one embodiment.

Figure 27B is a top plan view of the embodiment of Figure 27A.

Figure 27C is a rear elevation view of the embodiment of Figure 27A traversing a field with plants in rows.

Figure 27D is a partial perspective view from the bottom of the embodiment of Figure 27A with some components removed for clarity.

Figure 27E is a partial perspective view of the embodiment of Figure 27A with some components removed for clarity.

Figure 27F is a partial bottom view of the embodiment of Figure 27A with an optional stop with some components removed for clarity.

Figure 27G is a partial top view of the embodiment of Figure 27A showing optional bias element 2748.

Figure 28A is a top view of an application unit with a damper according to one embodiment.

Figure 28B is a top view of an application unit with a damper according to one embodiment.

Figure 28C is a top view of an application unit with a damper according to one embodiment.

Figure 28D is a top view of an application unit with a damper according to one embodiment.

SUMMARY

Described herein are systems, implements, and application units having mechanisms for placement of applications to agricultural plants of agricultural fields. In one embodiment, an application unit includes a frame to be positioned in operation between two rows of plants and a first plurality of flexible members coupled to the frame in operation such that the first plurality of flexible members guide a lateral position of the frame to be approximately equidistant from the two rows of plants based upon whether at least one flexible member of the first plurality of flexible members contacts one or more plants of the two rows of plants. The first plurality of flexible members include a plurality of fluid outlets for spraying crop input in close proximity to the rows of plants. In one example, the application unit also includes a second plurality of flexible members for guiding a lateral position of a base member that is coupled to the frame.

In one embodiment, an application unit comprising: a frame to be positioned in operation between first and second rows of plants; a first plant contacting member being pivotally coupled to the frame in operation such that the first plant contacting member to be deflected rearwardly with respect to a direction of motion of the frame upon the first
5 plant contacting member contacting at least one of the plants of the first row of plants which causes a first change in orientation of the first plant contacting member with respect to the frame; and a first outlet for applying a liquid application to the first row of plants with the first outlet being mechanically linked to the first plant contacting member, wherein the first change in orientation causes a corresponding second change in
10 orientation of the first outlet with respect to the frame.

In one embodiment, an application unit comprising: a frame to be positioned in operation between two rows of plants; a base member coupled to the frame, the base member to be positioned in proximity to a ground surface while in operation; and first and second plant guidance members coupled to the base member in operation such
15 that the first and second plant guidance members guide a lateral position of the base member to be approximately equidistant from the two rows of plants based upon whether at least one of the first and second plant guidance members contacts one or more plants of the two rows of plants.

In one embodiment, an application unit comprising: a frame to be positioned in operation between two rows of plants; a base member coupled to the frame; and at
20 least one linkage member for conveying fluid coupled to a biasing element of the base member in operation such that the biasing element biases an angular position of the at least one linkage member.

An application unit comprising: a frame to be positioned in operation between two
25 rows of plants; and a first plurality of flexible members coupled to the frame in operation such that the first plurality of flexible members guide a lateral position of the frame to be approximately equidistant from the two rows of plants based upon whether at least one of the first plurality of flexible members contacts one or more plants of the two rows of plants.

30 In one embodiment, a fluid applicator for applying fluid to plants in rows in a field comprising: at least one applicator arm that is actuated by an actuator to move the applicator arm from a position in the row between plants to a position adjacent to the plant.

In one embodiment, a fluid applicator for applying fluids to plants in rows in a field comprising: a base, at least one flexible or pivoting application member connected to the base and disposed to apply fluid to the plants, and a stabilizer associated with the at least one flexible or pivoting application member, wherein the stabilizer comprises at least one of:

- a) a spring disposed over the at least one flexible application member,
- b) a reinforcement that is disposed on or in the at least one application member and disposed along a length of the at least one application member,
- c) a wire attached to the at least one application member, the wire having a length to contact at least one plant, and
- d) a damper.

In one embodiment, a fluid applicator for applying fluids to plants in rows in a field comprising: a frame; a coulter connected to the frame and disposed to open a trench between the rows of plants; at least one application member connected to the frame or to the coulter and disposed to apply fluid to a rhizosphere of the plants.

In one embodiment, a fluid applicator for applying fluids to plants in rows in a field comprising: a base disposed between plants in adjacent rows, at least one application member connected to the base and disposed to apply fluid to the plants in a rhizosphere of the plants, and a nozzle disposed at an end of the application member for dispensing fluid from the application member to the plants in the rhizosphere of the plants.

In one embodiment, a trench closer for a fertilizer applicator comprising, a bar moved through a field transverse to a direction of travel, a fertilizer applicator connected to the bar for forming a trench in soil, wherein the fertilizer applicator comprises a coulter, a knife, or a coulter and a knife, and a trench closer disposed behind the fertilizer applicator in the direction of travel and connected to the fertilizer applicator or the bar, wherein the trench closer is not a disk that rolls in a direction of travel.

DETAILED DESCRIPTION

Described herein are systems, implements, and application units having mechanisms for placement of applications to agricultural plants of agricultural fields.

In an embodiment, an application unit includes a frame to be positioned in operation between first and second rows of plants, a first plant contacting member being pivotally coupled to the frame in operation such that the first plant contacting member to

be deflected rearwardly with respect to a direction of motion of the frame upon the first plant contacting member contacting at least one of the plants of the first row of plants which causes a first change in orientation of the first plant contacting member with respect to the frame. A first outlet applies a fluid application to the first row of plants.

5 The first change in orientation causes a corresponding second change in orientation of the first outlet with respect to the frame.

Each application unit includes components (e.g., planting contacting members, feelers, guidance members, linkage members, flexible members, etc) for obtaining a proper placement (e.g., orientation and/or positioning) of one or more fluid outlets with
10 respect to rows of plants in an agricultural field. The fluid outlets are then able to precisely apply (spray or dribble) the fluid applications on a desired target region (e.g., rhizosphere, a bottom portion of a plant, root ball, crown, crown root, mesocotyl, below a first node of a plant) of rows of plants to more efficiently spray plants at a lower cost due to less wasted crop input (e.g., nutrients, fertilizer, fungicide, herbicide or
15 insecticide).

In the following description, numerous details are set forth. It will be apparent, however, to one skilled in the art, that embodiments of the present disclosure may be practiced without these specific details. In some instances, well-known structures and devices are shown in block diagram form, rather than in detail, in order to avoid
20 obscuring the present disclosure.

Figure 1 shows an example of a system 100 for performing agricultural operations (e.g., applying fluid applications to plants) of agricultural fields including operations of an implement having application units in accordance with one embodiment. For example and in one embodiment, the system 100 may be
25 implemented as a cloud based system with servers, data processing devices, computers, etc. Aspects, features, and functionality of the system 100 can be implemented in servers, planters, planter monitors, sprayers, sidedress bars, combines, laptops, tablets, computer terminals, client devices, user devices (e.g., device 190), handheld computers, personal digital assistants, cellular telephones, cameras, smart
30 phones, mobile phones, computing devices, or a combination of any of these or other data processing devices.

In other embodiments, the system 100 includes a network computer or an embedded processing device within another device (e.g., display device) or within a machine (e.g., planter, combine), or other types of data processing systems having

fewer components or perhaps more components than that shown in Figure 1. The system 100 (e.g., cloud based system) and agricultural operations can control and monitor fluid applications using an implement or machine. The system 100 includes machines 140, 142, 144, 146 and implements 141, 143, 145 coupled to a respective
5 machine 140, 142, 144, 146. The implements (or machines) can include flow devices for controlling and monitoring fluid applications (e.g., spraying, fertilization) of crops and soil within associated fields (e.g., fields 102, 105, 107, 109). The system 100 includes an agricultural analysis system 102 that includes a weather store 150 with current and historical weather data, weather predictions module 152 with weather predictions for
10 different regions, and at least one processing system 132 for executing instructions for controlling and monitoring different operations (e.g., fluid applications). The storage medium 136 may store instructions, software, software programs, etc for execution by the processing system and for performing operations of the agricultural analysis system 102. In one example, storage medium 136 may contain a fluid application prescription
15 (e.g., fluid application prescription that relates georeferenced positions in the field to application rates). The implement 141 (or any of the implements) may include an implement 200 whose pump, flow sensors and/or flow controllers may be specifically the elements that are in communication with the network 180 for sending control signals or receiving as-applied data.

20 An image database 160 stores captured images of crops at different growth stages. A data analytics module 130 may perform analytics on agricultural data (e.g., images, weather, field, yield, etc.) to generate crop predictions 162 relating to agricultural operations.

A field information database 134 stores agricultural data (e.g., crop growth stage,
25 soil types, soil characteristics, moisture holding capacity, etc.) for the fields that are being monitored by the system 100. An agricultural practices information database 135 stores farm practices information (e.g., as-applied planting information, as-applied spraying information, as-applied fertilization information, planting population, applied nutrients (e.g., nitrogen), yield levels, proprietary indices (e.g., ratio of seed population
30 to a soil parameter), etc.) for the fields that are being monitored by the system 100. An implement can obtain fluid application data from the CMUs and provide this data to the system 100. A cost/price database 138 stores input cost information (e.g., cost of seed, cost of nutrients (e.g., nitrogen)) and commodity price information (e.g., revenue from crop).

The system 100 shown in Figure 1 may include a network interface 118 for communicating with other systems or devices such as drone devices, user devices, and machines (e.g., planters, combines) via a network 180 (e.g., Internet, wide area network, WiMax, satellite, cellular, IP network, etc.). The network interface includes one
5 or more types of transceivers for communicating via the network 180.

The processing system 132 may include one or more microprocessors, processors, a system on a chip (integrated circuit), or one or more microcontrollers. The processing system includes processing logic for executing software instructions of one or more programs. The system 100 includes the storage medium 136 for storing
10 data and programs for execution by the processing system. The storage medium 136 can store, for example, software components such as a software application for controlling and monitoring fluid applications or any other software application. The storage medium 136 can be any known form of a machine readable non-transitory storage medium, such as semiconductor memory (e.g., flash; SRAM; DRAM; etc.) or
15 non-volatile memory, such as hard disks or solid-state drive.

While the storage medium (e.g., machine-accessible non-transitory medium) is shown in an exemplary embodiment to be a single medium, the term “machine-accessible non-transitory medium” should be taken to include a single medium or multiple media (e.g., a centralized or distributed database, and/or associated caches
20 and servers) that store the one or more sets of instructions. The term “machine-accessible non-transitory medium” shall also be taken to include any medium that is capable of storing, encoding or carrying a set of instructions for execution by the machine and that cause the machine to perform any one or more of the methodologies of the present disclosure. The term “machine-accessible non-transitory medium” shall
25 accordingly be taken to include, but not be limited to, solid-state memories, optical and magnetic media, and carrier wave signals. Figure 2 illustrates an architecture of an implement 200 for delivering applications (e.g., fluid applications, fluid mixture applications) to agricultural fields in accordance with one embodiment. The implement
30 200 includes at least one storage tank 250, flow lines 260 and 261, a flow controller 252 (e.g., valve), and at least one variable-rate pump 254 (e.g., electric, centrifugal, piston, etc.) for pumping and controlling application rate of a fluid (e.g., fluid application, semifluid mixture) from the at least one storage tank to different application units 210-217, respectively of the implement. At least one flow sensor 270 can be utilized on the implement 200 either row-by-row or upstream of where the fluid branches out to the

application units as illustrated in Figure 2. The flow controller 252 can be row-by-row as opposed to implement-wide as shown in FIG. 2.

The applications units are mechanically coupled to the frames 220-227 which are mechanically coupled to a bar 10. Each application unit 210-217 can include flow
5 sensors and components having a placement mechanism (e.g., planting contacting members, feelers, guidance members) for obtaining a proper orientation and/or positioning of a fluid outlet with respect to a plant in an agricultural field. The application units can include any of the embodiments described herein in conjunction with Figures 3A, 3B, 4-11, and 13A and 13B.

10 Figure 3A illustrates a rear view of an application unit 300 (e.g., a fluid application unit) 300 for applying an application to plants P-1, P-2 (e.g., corn plants, soy bean plants, etc.) in accordance with one embodiment. It should be appreciated that the unit 300 is illustrated traveling in a direction D into the page in Figure 3A (rear view 302) and traveling upward in Figure 3B (top view 350) along a direction D. The application unit
15 300 is preferably mounted to a transversely extending bar 10 (e.g., toolbar or boom) drawn by a tractor or other implement. The application unit 300 preferably extends laterally between existing corn plants P-1, P-2 as the bar 10 traverses the field having a ground surface 390.

Continuing to refer to Figure 3A (rear view), the fluid application unit 300
20 preferably comprises a downwardly-extending frame 310 to which feelers 320a, 320b and fluid outlets 330a, 330b are preferably pivotally connected. As shown in Figure 3B (top view 350), the feelers 320 preferably pivot with a range of angular motion 321a, 321b about an axis parallel to the frame 310, e.g., a vertical axis. In operation, when the feelers 320a, 320b contact passing plants (e.g., P-1, P-2), the feelers 320a, 320b
25 preferably deflect rearwardly in a downward direction. A spring element (not shown) or other biasing element preferably biases the feelers 320a, 320b into a neutral position 360a, 360b to which the feeler preferably returns when not deflected by a plant or other obstacle. A length of the feelers 320a, 320b may be designed based on a row spacing (e.g., 20", 30", etc.) with each feeler 320a, 320b having a length of approximately one
30 half of the row spacing between rows of plants. In one example, the feelers 320a, 320b may have adjustable lengths depending on the row spacing for a field.

Each feeler 320 is preferably operatively mechanically linked to one of the fluid outletfluid outlets 330 such that a change in orientation of the feeler 320 relative to the frame 310 changes an orientation of the linked fluid outlet 330.

In the embodiment of Figure 3A (rear view), rearward angular deflection of the feeler 320 (e.g., 320a, 320b) results in corresponding (e.g., equal) angular deflection with a range of angular motion 331a, 331b of the fluid outlet 330 (e.g., 330a, 330b) linked to the feeler. A rigid link 325 (e.g., 325a, 325b) constrains the fluid outlet 330 to
5 pivot in a synchronized fashion with the feeler 320. The fluid outlet 330 preferably pivots about an axis which is preferably parallel to the frame 310. The pivot axis of the fluid outlet 330 is preferably parallel to and preferably substantially aligned with the pivot axis of the feeler 320. As a result, a spray S (e.g., pressurized spray Sa, Sb) emitted from the fluid outlet 330 (e.g., via orifices 332a, 332b) preferably disposed at a distal
10 end of the outlet) is preferably oriented toward a plant P-1, P-2 contacted by the feeler 320.

In another embodiment, the fluid application unit 300 includes a single fluid outlet and a single feeler for spraying a single row of plants. In one example, the application unit 300 includes the feeler 320a and the fluid outlet 330a for spraying the row of plants
15 P-1. The feeler 320b and fluid outlet 330b are not included in this example. A different application unit is provided for spraying the plants P-2.

In another example, the application unit 300 includes the feeler 320b and the fluid outlet 330b for spraying the row of plants P-2. The feeler 320a and fluid outlet 330a are not included in this example. A different application unit is provided for spraying the
20 plants P-1.

In another embodiment, the fluid application unit 300 includes at least one fluid outlet (e.g., 330a, 330b) and no feelers 320, 320b and no link 325a, 325b. The at least fluid outlet is positioned and/or oriented to spray a fluid towards a base region of a plant (e.g., into soil within 3-4 inches of the base region of the plant, towards a region in
25 which a base of the plant emerges from the soil).

It should be appreciated that each fluid outlet in the various embodiments described herein is preferably in fluid communication with a source (e.g., tank 250) containing an application (e.g., fluid application, crop inputs such as fertilizer, fungicide, herbicide or insecticide). Each fluid outlet described herein provides a pressurized spray
30 (e.g., 1-200 psi, 5-100 psi, etc.) in a direction (e.g., substantially downward direction) towards a base region of a plant (e.g., into soil within 3-4 inches of the base region of the plant, towards a region in which a base of the plant emerges from the soil). In another example, at least one fluid outlet of an application unit provides a dribble of liquid (e.g., non-pressurized source) rather than a pressurized spray.

In the embodiment of an application unit 400 (e.g., fluid application unit 400) shown in Figure 4 (rear view 402), the frame 410 supports a feeler 420 which preferably functions similarly to the unit 300 described above. The frame 410 may be coupled to a bar 10 in a similar manner as the frame 310 is coupled to the bar 10 in Figure 3A. As
5 described in more detail herein, rearward deflection (out of the page) of the feeler 420 preferably causes the fluid outlet 430 to deflect in a transverse vertical plane (e.g., generally up and down along the view of Figure 4 (rear view)). In one example, when a transverse distance between frame 410 and an adjacent plant P-3 decreases, the feeler is pivoted rearward with respect to a neutral position of the feeler, preferably causing
10 the fluid outlet 430 to pivot downward such that a spray S-3 emitted by the fluid outlet 430 (e.g., from a fluid orifice 432 preferably disposed at a distal end thereof) is directed more closely toward a bottom portion (e.g., root ball, crown, crown root, mesocotyl) of the plant. Conversely, when a transverse distance between frame 410 and an adjacent plant P-3 increases, a biasing element (not shown) causes the feeler to pivot forward
15 with respect to a neutral position of the feeler, preferably causing the fluid outlet to pivot upward such that the spray S-3 is directed more closely toward the bottom portion of the plant or towards soil within 0-4 inches of the bottom portion of the plant.

Referring to the illustrated embodiment of Figure 4 (rear view) in more detail, the feeler 420 preferably pivots about a central vertical axis of the frame 410, which is
20 preferably round in cross-section. A link 411 preferably constrains a horizontal gear 415 to rotate about the central vertical axis of the frame 410. The central vertical axis is substantially perpendicular with respect to a ground surface 490. The horizontal gear 415 preferably drives a vertical gear 425 (e.g., teeth of gear 415 engage with teeth of gear 425), which preferably selectively raises or lowers the outlet 430, e.g., by winding
25 or unwinding a support cable 429 which may be wound around a drive shaft of the vertical gear 425 at an upper end thereof and attached to the outlet 430 at a lower end thereof.

The embodiments described herein may include a pair of feelers each having an associated (e.g., linked) fluid outlet. In other embodiments, the fluid outlets may be
30 constrained (e.g., by a linkage) to pivot at equal and opposite angles, and one of the outlets may be associated with (e.g., linked to) a single feeler.

The feelers 320, 420 described herein may contact the adjacent plants at any location. In a preferred embodiment, each feeler is preferably disposed to contact an adjacent plant on a stem or stalk thereof; for example, the feeler may be disposed

adjacent the ground in order to contact the stalk at a location immediately above the soil (e.g., above the crown and below the lowest node of the plant). In some such embodiments, the fluid outlet may be disposed above the feeler instead of below the feeler as illustrated in Figure 5 in accordance with one embodiment.

5 In the embodiment of an application unit 500 (e.g., fluid application unit 500) shown in Figure 5 (rear view 502), the frame 510 supports a feeler 520 which preferably functions similarly to the unit 400 described above. As described in more detail herein, rearward deflection of the feeler 520 preferably causes the fluid outlet 530 to deflect in a transverse vertical plane (e.g., generally up and down along the view of Figure 5 (rear
10 view)). When a transverse distance between frame 510 and an adjacent plant P-4 decreases, the feeler 520 is pivoted rearward with respect to a neutral position of the feeler 520, preferably causing the fluid outlet 530 to pivot downward such that a spray S-4 emitted by the fluid outlet 530 (e.g., from a fluid orifice 532 preferably disposed at a distal end thereof) is directed more closely toward a bottom portion (e.g., root ball,
15 crown, crown root, mesocotyl) of the plant that is in close proximity to a ground surface 590. Conversely, when a transverse distance between frame 510 and an adjacent plant P-4 increases, a biasing element (not shown) causes the feeler to pivot forward with respect to a neutral position of the feeler 520, preferably causing the fluid outlet 530 to pivot upward such that the spray S-4 is directed more closely toward the bottom portion
20 of the plant (e.g., within 0-4 inches of the bottom portion of the plant).

 In still another embodiment of a fluid application unit 600 illustrated in Figure 6A (side view 602) and Fig. 6B (top view 604), a downwardly and preferably rearwardly extending frame 620 (e.g., a flexible, or semi-flexible frame) is fixed to the bar 10 at an upper end thereof by a bracket 610. A base member 630 supported at a lower end of
25 the frame 620 is preferably disposed adjacent a ground surface 690 and may have a lower curved surface for riding (continuously or discontinuously) along the ground surface. Fluid outlets 640a, 640b are preferably supported by the base member 630 and are preferably disposed to apply a fluid to the plants P-5, P-6 (e.g., at a lower portion of each plant such as at a crown thereof). The fluid outlets 640a, 640b may
30 have orifices disposed at a distal end thereof for forming a spray which is preferably directed toward the plants. Guidance members 650a, 650b preferably guide the lateral position of the base member 630; e.g., contact between the guidance members 650a, 650b and stems of plants P-5, P-6 may deflect the frame 620 to allow the base member 630 to remain equidistant from each row of plants P-5, P-6 adjacent to the base

member 630. The guidance members 650 are preferably made of a semi-flexible or semi-rigid material such as spring steel and may include a spring coil 652 for permitting the guidance member 650a, 650b to deflect when encountering obstacles. The guidance members 650 may include a first portion 655a, 656a extending outwardly and rearwardly toward the row of plants, a second portion 655b, 656b extending generally parallel to the row of plants, and a third portion 655c, 656c extending inwardly and rearwardly away from the row of plants. In one embodiment, all base members adjust their position with respect to the rows of plants.

A width (W) of the guidance members may be designed based on a row spacing (e.g., 20", 30", etc.) with each guidance member having a length of slightly less than approximately one half of the row spacing between rows of plants. In one example, the guidance members may have adjustable widths depending on the row spacing for a field.

In one example, the application unit 600 includes at least one fluid outlet (e.g., 640a, 640b) that sprays or dribbles fluid towards a base region of the plants P-5, P-6. The base member 630 contacts a ground surface 690 in a continuous or non-continuous manner along the ground surface. A flexible frame 620 couples the base member 630 to a bar 610. In another embodiment, the application unit 600 does not include guidance members 650a, 650b. At least one fluid outlet 640a, 640b sprays the fluid towards a base region of the plants P-5, P-6.

In another embodiment of a fluid application unit 700 illustrated in Figure 7 (rear view 702), a downwardly extending frame 710 is preferably permitted to slide up and down as indicated by arrows 722 relative to the bar 10 but retained to the bar 10 by a collar 720 extending around the frame 710 at an upper end thereof. The unit 700 is preferably functionally similarly to the unit 300 except the unit 700 includes a ground engaging element 712, a collar 720, and an internal channel 750 for directing fluid through the frame 710. A ground-engaging element 712 (e.g., a wheel or ski) is preferably mounted to a lower end of the frame 710 and disposed to contact the ground during operation such that a fluid outlet 730 retains its position relative to the ground surface in operation. One or more feelers and related linkage mechanisms for reorienting the fluid outlet (as described herein according to various embodiments) may additionally be incorporated in the unit 700. The frame 710 may include a fluid inlet 740 that is in fluid communication with an internal channel 750 (e.g., formed within the frame and/or disposed within the frame) for directing fluid to the fluid outlet 730. The fluid

outlet 730 may additionally include an internal channel 760 (e.g., formed as a part within fluid outlet 730 and/or disposed within the fluid outlet 730) for directing fluid to the distal end (e.g., orifice 732) of the fluid outlet 730. The channels 750 and 760 are preferably in fluid communication via a flexible conduit (not shown) such as a hose or tube. The fluid inlet 740 may be in fluid communication with a flexible conduit that is in fluid communication with a fluid source (e.g., tank).

Referring to Figure 8A (rear view 802), an embodiment of a fluid application unit 800 is illustrated which is substantially similar to the application unit 300 described herein, except that the frame 810 is coupled to or includes one or more opening discs 811a, 811b (e.g., vertical coulters, angled opening discs) for opening a trench T in the soil. The frame 810 preferably includes an internal or externally mounted conduit (not shown) for applying a crop input (e.g., fluid crop input such as anhydrous or other fertilizer, nutrients, etc.) into the trench T. The frame 810 may comprise an injection assembly (e.g., sidedress liquid fertilizer injection assembly or anhydrous injection assembly) such as those illustrated in FIG. 7 of U.S. Patent No. 5,890,445, incorporated herein by reference or in U.S. Patent No. 8,910,581, incorporated by reference; the fluid outlets 830a, 830b, and feelers 820a, 820b, as well as related linkage structure are preferably fixed to the sides of such an injection assembly for spraying a fluid on nearby plants P-6.

The fluid outlets 830a, 830b preferably pivot about an axis which is preferably parallel to the frame 810. The pivot axis of the fluid outlets 830a, 830b is preferably parallel to and preferably substantially aligned with the pivot axis of the feelers 820a, 820b. As a result, a spray S (e.g., Sa, Sb) emitted from the fluid outlets 830a, 830b (e.g., via orifices 832a, 832b) preferably disposed at distal ends of the outlets) is preferably oriented toward a plant P-7, P-8 contacted by the feelers 820a, 820b. A lower end of the frame 810 may also contain a fluid outlet 830c for emitted a spray Sc into the trench T. It should be appreciated that each fluid outlet 830a, 830b in the various embodiments described herein is preferably in fluid communication with a source (e.g., tank 250) containing an application (e.g., fluid application, crop inputs such as fertilizer, fungicide, herbicide or insecticide).

The optional feelers 820 described herein may contact the adjacent plants at any location. In a preferred embodiment, each feeler 820 is preferably disposed to contact an adjacent plant on a stem or stalk thereof; for example, the feeler may be disposed adjacent the ground in order to contact the stalk at a location immediately above the soil

(e.g., above the crown and below the lowest node of the plant). In some such embodiments, the fluid outlet 830 may be disposed above the feeler 820 instead of below the feeler 830 as illustrated in Figure 3 in accordance with one embodiment.

In another example, the application unit 800 does not include the optional feelers 5 820a, 820b. At least one fluid outlet (e.g., 820a, 820b) sprays or dribbles fluid towards a base region of the plants P-7, P-8 while the fluid outlet 830a sprays or dribbles the fluid into the trench T. A distal end of at least one fluid outlet (e.g., 820a, 820b) extends closer (e.g., within 0-6 inches) to a base region of the plants when the liquid is dribbled towards the base region of the plants in comparison to when the fluid is sprayed.

10 Referring to Figure 8B (rear view 852), an embodiment of a liquid application unit 850 is illustrated which is substantially similar to the application unit 300 described herein, except that the frame 810 is coupled to or includes one or more opening discs 818 (e.g., vertical coulter) for opening a trench Tc in the soil, optional trench forming members 860 and 862 (e.g., scrapers, knives) for opening shallow trenches Td and Te, 15 respectively, in the soil, and no feelers. One or more feelers and related linkage mechanisms for reorienting the fluid outlet (as described herein according to various embodiments) may additionally be incorporated in the unit 850.

The frame 810 preferably includes an internal or externally mounted conduit (not shown) for applying a crop input (e.g., liquid crop input such as anhydrous or other 20 fertilizer, nutrients, etc.) into the trenches. The frame 810 may comprise an injection assembly (e.g., sidedress liquid fertilizer injection assembly or anhydrous injection assembly) such as those illustrated in FIG. 7 of U.S. Patent No. 5,890,445, incorporated herein by reference or in U.S. Patent No. 8,910,581, incorporated by reference; the fluid outlets 830a, 830b, as well as related linkage structure are preferably fixed to the sides 25 of such an injection assembly for spraying or dribbling a liquid on nearby plants.

The fluid outlets 830a, 830b preferably pivot about an axis which is preferably parallel to the frame 810. The fluid outlet 830c is formed near a disc 818 and the fluid outlets 830d, 830e are formed near a corresponding trench forming member 860, 862. As a result, a spray S (e.g., Sa, Sb, Sd, Se) or dribble emitted from the fluid outlets 30 preferably disposed at distal ends of the outlets) is preferably oriented toward plants P-7, P-8. A lower end of the frame 810 may also contain a fluid outlet 830c for emitted a spray Sc into the trench T. It should be appreciated that each fluid outlet in the various embodiments described herein is preferably in fluid communication with a source (e.g.,

tank 250) containing an application (e.g., fluid application, crop inputs such as fertilizer, fungicide, herbicide or insecticide).

In one example, a tractor or other implement pulls multiple side dressing fertilizer coulter units (e.g., application unit 850) for forming a trench Tc having a depth (e.g., 4-8 inches, approximately 5-7 inches, etc.). The crop may be at a seedling stage when fertilizer is typically applied as a side dressing slightly offset laterally from each row of seedlings. Each application unit includes a frame (not shown), a coulter disc or wheel 818 for forming a deeper trench having a depth (e.g., 4-8 inches, approximately 5-7 inches, etc.) with a lateral position approximately equidistant between the plants P-7, P-8, a trench forming member 860 (e.g., scratching knife 860) for opening a shallow trench Td having a shallow depth (e.g., 0-4 inches, 0-2 inches, approximately 1 inch) in proximity to a row of plants P-8 (e.g., a lateral position within 5-10 inches of the plants P-8), and a trench forming member 862 (e.g., scratching knife 862) for opening a shallow trench having a shallow depth (e.g., 0-4 inches, 0-2 inches, approximately 1 inch) in proximity to a row of plants P-7 (e.g., a lateral position within 5-10 inches of the plants P-7). The frame 810 preferably includes an internal or externally mounted conduit (not shown) for applying a crop input (e.g., fluid crop input such as anhydrous or other fertilizer, nutrients, etc.) with fluid outlets into a respective trench. Each knife may be associated with a respective covering tine (e.g., rake, closing wheel) for closing the shallow trench to retain the crop input in the soil (or ground) and prevent the crop input from being volatilized.

In another example, the disc 818 and fluid outlet 830c are not included in the application unit 850 and at least one of the members 860 and 862 is included in the application unit 850. In another example, only one of the trench forming members 860 and 862 is included in the application unit 850.

Figure 9A illustrates a top view 902 of an application unit 900 (e.g., a fluid application unit) 900 for applying an application to plants P-9, P-10 (e.g., corn plants, soy bean plants, etc.) in accordance with one embodiment. It should be appreciated that the unit 900 is illustrated traveling in a direction D upwards in Figures 9A and 9B. The application unit 900 is preferably mounted to a transversely extending bar 10 (e.g., toolbar or boom) drawn by a tractor or other implement. The application unit 900 preferably extends laterally between existing corn plants as the bar 10 illustrated in Figure 9C traverses the field having a ground surface 990.

In Figure 9A (top view), the fluid application unit 900 preferably comprises a base 912 to which linkage members 920a, 920b are preferably pivotally connected. The linkage members 920a, 920b are coupled to flexible members 922a, 922b that may contact the rows of plants in operation. In operation, when the flexible members 922a, 922b contact passing plants (e.g., P-9, P-10), the flexible members 922a, 922b preferably cause rearwardly deflection of the linkage members 920a, 920b from a neutral position 960 to a rearward deflection position as illustrated in Figures 9A and 9B. A spring element 914, 915 or other biasing element (e.g., spring and hinge) preferably biases the linkage members 920a, 920b into a neutral position 960 to which the linkage members 920a, 920b preferably return when not deflected by a plant or other obstacle. A length of the linkage members 920a, 920b and flexible members 922a, 922b may be designed based on a row spacing (e.g., 20", 30", etc.) with each linkage member 920a, 920b having a length of approximately one half of the row spacing between rows of plants. In one example, the linkage members 920a, 920b may have adjustable lengths depending on the row spacing for a field.

Figure 9A illustrates a top view 902 in which the linkage members 920a, 920b are biased in a centered position between rows of plants such that the base 912 is approximately equidistant from the plants P-9 and P-10. Figure 9B illustrates a top view 904 in which the linkage members 920a, 920b are biased in a non-centered position between rows of plants such that the base 912 is laterally positioned closer to the plants P-10 than the plants P-9.

Figure 9C illustrates a side view 940 of the application unit 900 in accordance with one embodiment. The application unit 900 is preferably mounted to a transversely extending bar 10 (e.g., toolbar or boom) drawn by a tractor or other implement. A frame 910 (e.g., rigid frame) is coupled to the bar 10 and the base 912. In one example, the base 912 is positioned a certain distance above the ground 990, the linkage members 920a, 920b slope downwards towards the ground, and the flexible members 922a, 922b are positioned in a horizontal plane slightly above the ground (e.g., 1-12 inches above the ground).

A fluid outlet 930 can be positioned with respect to the linkage member 920a, 920b or flexible members 922a, 922b for spraying a fluid in close proximity to the plants. In one example, the fluid outlet 930 is positioned at a distal end of the linkage member 920a, 920b and generates a spray Sa that sprays in a downward directions towards a base region of plants P-9. It should be appreciated that each fluid outlet 930 in the

various embodiments described herein is preferably in fluid communication with a source (e.g., tank 250) containing an application (e.g., fluid application, crop inputs such as fertilizer, fungicide, herbicide or insecticide).

Figure 9D illustrates a top view 952 of application units 950, 980 (e.g., a fluid application unit) for applying an application to plants P-9, P-10 (e.g., corn plants, soy bean plants, etc.) in accordance with one embodiment. The application units 950, 980 are preferably mounted to a transversely extending bar 10 (e.g., toolbar or boom) drawn by a tractor or other implement. The application units 950, 980 preferably extend laterally between existing corn plants as the bar 10 illustrated in Figure 9C traverses the field having a ground surface 990.

In Figure 9D (top view 952), the fluid application units 950 and 980 preferably each comprise a base 912, 972 to which linkage members 920, 984 are preferably pivotally connected. The base 912 and 972 are each coupled with a frame to a bar 10. The linkage members 920, 984 are coupled to flexible members 922a, 982a that may contact the rows of plants in operation. In operation, when the flexible members 922a, 982a contact passing plants (e.g., P-9, P-10), the flexible members 922a, 982a preferably cause rearwardly deflection of the linkage members 920, 984 from a neutral position 960 to a rearward deflection position as illustrated in Figure 9D. A spring element 914, 974 or other biasing element (e.g., spring and hinge) preferably biases the linkage members 920, 984 into a neutral position 960 to which the linkage members preferably return when not deflected by a plant or other obstacle. A length of the linkage members 920, 984 and flexible members 922a, 982a may be designed based on a row spacing (e.g., 20", 30", etc.) with each linkage member 920, 984 having a length of approximately one half of the row spacing between rows of plants. In one example, the linkage members 920, 984 may have adjustable lengths depending on the row spacing for a field. Fluid outlets 930, 981 can be positioned with respect to the linkage members 920, 984 or flexible members 922a, 982a for spraying a fluid in close proximity to the plants. In one example, the fluid outlet is positioned at a distal end of the linkage members 920, 984 and generates a spray or dribble that applies in a downward direction towards a base region of plants P-9, P-10.

At least one of the frame 910 and base (e.g., 912, 972) illustrated in Figures 9A-9D may be coupled to or include one or more opening discs/coulter (e.g., 811a, 811b, 818, 1318, etc.) for opening a trench in the soil and also optional trench forming

members (e.g., trench forming members 860, 862, 1360, 1362, scrapers, knives) for opening shallow trenches in the soil.

Figure 10 illustrates a side view of an application unit 1000 in accordance with one embodiment. The application unit 1000 is preferably mounted to a transversely
5 extending bar 10 (e.g., toolbar or boom) drawn by a tractor or other implement. A frame 1010 (e.g., rigid frame 1010) is coupled to the bar 10, a flexible frame 1011, and a base 1012. The base 1012 can be coupled to a sloped member 1014 (e.g., ski, ground contacting member) and a linkage member 1020a which is coupled to a flexible member 1022a. In one example, these components of the application unit 1000 function in a
10 similar manner in comparison to the frame, base, linkage members, and flexible members of the application unit 900 except that the base 1012 and flexible member 1022a (or any other flexible member) at least partially contact the ground 1090 while in operation with the application unit 1000 moving in a direction D that is substantially parallel with respect to a row of plants P-11. The sloped member 1014 can partially
15 contact the ground or be in close proximity to the ground to provide a more uniform ground surface for the base 1012 which partially contacts the ground.

A fluid outlet 1030 can be positioned with respect to the linkage member or flexible members for spraying a fluid in close proximity to the plants. In one example, the fluid outlet is positioned at a distal end of the linkage member 1020a and generates
20 a spray Sa that sprays in a downward direction towards a base region of plants P-11. It should be appreciated that each fluid outlet 1030 in the various embodiments described herein is preferably in fluid communication with a source (e.g., tank 250) containing an application (e.g., fluid application, crop inputs such as fertilizer, fungicide, herbicide or insecticide).

25 In another embodiment, the application unit 1000 does not include flexible member 1022a and the frame 1011 or the frame 1010 may also be optional. At least one fluid outlet (e.g., 1030) sprays the fluid towards a base region of the plants P-11.

Figure 11 illustrates a rear view 1102 of an application unit 1100 in accordance with one embodiment. The application unit 1100 is preferably mounted to a transversely
30 extending bar 10 (e.g., toolbar or boom) drawn by a tractor or other implement. A frame 1110 (e.g., rigid frame 1110) is coupled to the bar 10, a frame 1112 which is coupled to an optional base member 1140 having an angle 1104 with respect to the frame 1112. The base member 1140 is positioned in a plane (e.g., a substantially horizontal plane) above the ground 1190. The frame 1112 provides support for flexible members 1113-

1118 and the base member 1140 may also provide support for additional flexible members (e.g., 1141-1142). The flexible members have a neutral position that is parallel to a longitudinal axis of the bar 10 if the flexible members are not in contact with plants or other objects. In operation in which the application unit 1100 moves in a
5 direction D, the flexible members contact rows of plants and bend to provide a lateral position of the frame 1110, 1112, and base member 1140 that is approximately equidistant with respect to rows of plants. The flexible members are arranged on the frame 1112 and optional base member 1140 in a leaf like shape and pattern of flexible members. A distal region of at least a plurality of the flexible members contains fluid
10 outletfluid outlets 1171 and 1174 for spraying fluid in close proximity to the plants.

In one example, the fluid outlets are positioned approximately 0-10 inches from a distal end of a distal region of the flexible members and generate sprays Sa and Se that spray in a downward direction towards a base region of plants P-12, P-13. It should be appreciated that each fluid outlet in the various embodiments described herein is
15 preferably in fluid communication with a source (e.g., tank 250) containing an application (e.g., fluid application, crop inputs such as fertilizer, fungicide, herbicide or insecticide). Each fluid outlet described herein provides a pressurized spray (e.g., 1-200 psi, 5-100 psi, etc.) in a substantially downward direction towards a base region of a plant. Alternatively, a fluid outlet may dribble liquid (non-pressurized).

20 Figure 12 shows an example of a system 1200 that includes a machine 1202 (e.g., tractor, combine harvester, etc.) and an implement 1240 (e.g., planter, sidedress bar, cultivator, plough, sprayer, spreader, irrigation implement, etc.) in accordance with one embodiment. The machine 1202 includes a processing system 1220, memory 1205, machine network 1210 (e.g., a controller area network (CAN) serial bus protocol
25 network, an ISOBUS network, etc.), and a network interface 1215 for communicating with other systems or devices including the implement 1240. The machine network 1210 includes sensors 1212 (e.g., speed sensors), controllers 1211 (e.g., GPS receiver, radar unit) for controlling and monitoring operations of the machine or implement. The network interface 1215 can include at least one of a GPS transceiver, a WLAN
30 transceiver (e.g., WiFi), an infrared transceiver, a Bluetooth transceiver, Ethernet, or other interfaces from communications with other devices and systems including the implement 1240. The network interface 1215 may be integrated with the machine network 1210 or separate from the machine network 1210 as illustrated in Figure 12. The I/O ports 1229 (e.g., diagnostic/on board diagnostic (OBD) port) enable

communication with another data processing system or device (e.g., display devices, sensors, etc.).

In one example, the machine performs operations of a tractor that is coupled to an implement for fluid applications of a field. The flow rate of a fluid application for each
5 row unit of the implement can be associated with locational data at time of application to have a better understanding of the applied fluid for each row and region of a field. Data associated with the fluid applications can be displayed on at least one of the display devices 1225 and 1230.

The processing system 1220 may include one or more microprocessors,
10 processors, a system on a chip (integrated circuit), or one or more microcontrollers. The processing system includes processing logic 1226 for executing software instructions of one or more programs and a communication unit 1228 (e.g., transmitter, transceiver) for transmitting and receiving communications from the machine via machine network 1210 or network interface 1215 or implement via implement network
15 1250 or network interface 1260. The communication unit 1228 may be integrated with the processing system or separate from the processing system. In one embodiment, the communication unit 1228 is in data communication with the machine network 1210 and implement network 1250 via a diagnostic/OBD port of the I/O ports 1229.

Processing logic 1226 including one or more processors may process the
20 communications received from the communication unit 1228 including agricultural data (e.g., GPS data, fluid application data, flow rates, etc.). The system 1200 includes memory 1205 for storing data and programs for execution (software 1206) by the processing system. The memory 1205 can store, for example, software components such as fluid application software for analysis of fluid applications for performing
25 operations of the present disclosure, or any other software application or module, images (e.g., captured images of crops), alerts, maps, etc. The memory 1205 can be any known form of a machine readable non-transitory storage medium, such as semiconductor memory (e.g., flash; SRAM; DRAM; etc.) or non-volatile memory, such as hard disks or solid-state drive. The system can also include an audio input/output
30 subsystem (not shown) which may include a microphone and a speaker for, for example, receiving and sending voice commands or for user authentication or authorization (e.g., biometrics).

The processing system 1220 communicates bi-directionally with memory 1205, machine network 1210, network interface 1215, header 1280, display device 1230,

display device 1225, and I/O ports 1229 via communication links 1231-1236, respectively.

Display devices 1225 and 1230 can provide visual user interfaces for a user or operator. The display devices may include display controllers. In one embodiment, the display device 1225 is a portable tablet device or computing device with a touchscreen that displays data (e.g., fluid application data, captured images, localized view map layer, high definition field maps of as-applied fluid application data, as-planted or as-harvested data or other agricultural variables or parameters, yield maps, alerts, etc.) and data generated by an agricultural data analysis software application and receives input from the user or operator for an exploded view of a region of a field, monitoring and controlling field operations. The operations may include configuration of the machine or implement, reporting of data, control of the machine or implement including sensors and controllers, and storage of the data generated. The display device 1230 may be a display (e.g., display provided by an original equipment manufacturer (OEM)) that displays images and data for a localized view map layer, as-applied fluid application data, as-planted or as-harvested data, yield data, controlling a machine (e.g., planter, tractor, combine, sprayer, etc.), steering the machine, and monitoring the machine or an implement (e.g., planter, combine, sprayer, etc.) that is connected to the machine with sensors and controllers located on the machine or implement.

A cab control module 1270 may include an additional control module for enabling or disabling certain components or devices of the machine or implement. For example, if the user or operator is not able to control the machine or implement using one or more of the display devices, then the cab control module may include switches to shut down or turn off components or devices of the machine or implement.

The implement 1240 (e.g., planter, cultivator, plough, sprayer, spreader, irrigation implement, etc.) includes an implement network 1250, a processing system 1262, a network interface 1260, and optional input/output ports 1266 for communicating with other systems or devices including the machine 1202. The implement network 1250 (e.g., a controller area network (CAN) serial bus protocol network, an ISOBUS network, etc.) includes a pump 1256 for pumping fluid from a storage tank(s) 1290 to application units 1280, 1281, ...N of the implement, sensors 1252 (e.g., speed sensors, seed sensors for detecting passage of seed, downforce sensors, actuator valves, moisture sensors or flow sensors for a combine, speed sensors for the machine, seed force sensors for a planter, fluid application sensors for a sprayer, or vacuum, lift, lower

sensors for an implement, flow sensors, etc.), controllers 1254 (e.g., GPS receiver), and the processing system 1262 for controlling and monitoring operations of the implement. The pump controls and monitors the application of the fluid to crops or soil as applied by the implement. The fluid application can be applied at any stage of crop development
5 including within a planting trench upon planting of seeds, adjacent to a planting trench in a separate trench, or in a region that is nearby to the planting region (e.g., between rows of corn or soybeans) having seeds or crop growth.

For example, the controllers may include processors in communication with a plurality of seed sensors. The processors are configured to process data (e.g., fluid
10 application data, seed sensor data) and transmit processed data to the processing system 1262 or 1220. The controllers and sensors may be used for monitoring motors and drives on a planter including a variable rate drive system for changing plant populations. The controllers and sensors may also provide swath control to shut off individual rows or sections of the planter. The sensors and controllers may sense
15 changes in an electric motor that controls each row of a planter individually. These sensors and controllers may sense seed delivery speeds in a seed tube for each row of a planter.

The network interface 1260 can be a GPS transceiver, a WLAN transceiver (e.g., WiFi), an infrared transceiver, a Bluetooth transceiver, Ethernet, or other interfaces from
20 communications with other devices and systems including the machine 1202. The network interface 1260 may be integrated with the implement network 1250 or separate from the implement network 1250 as illustrated in Figure 12.

The processing system 1262 communicates bi-directionally with the implement network 1250, network interface 1260, and I/O ports 1266 via communication links
25 1241-1243, respectively.

The implement communicates with the machine via wired and possibly also wireless bi-directional communications 1204. The implement network 1250 may communicate directly with the machine network 1210 or via the networks interfaces 1215 and 1260. The implement may also be physically coupled to the machine for
30 agricultural operations (e.g., planting, harvesting, spraying, etc.).

The memory 1205 may be a machine-accessible non-transitory medium on which is stored one or more sets of instructions (e.g., software 1206) embodying any one or more of the methodologies or functions described herein. The software 1206 may also reside, completely or at least partially, within the memory 1205 and/or within

the processing system 1220 during execution thereof by the system 1200, the memory and the processing system also constituting machine-accessible storage media. The software 1206 may further be transmitted or received over a network via the network interface 1215.

5 In one embodiment, a machine-accessible non-transitory medium (e.g., memory 1205) contains executable computer program instructions which when executed by a data processing system cause the system to perform operations or methods of the present disclosure. While the machine-accessible non-transitory medium (e.g., memory 1205) is shown in an exemplary embodiment to be a single medium, the term “machine-
10 accessible non-transitory medium” should be taken to include a single medium or multiple media (e.g., a centralized or distributed database, and/or associated caches and servers) that store the one or more sets of instructions. The term “machine-accessible non-transitory medium” shall also be taken to include any medium that is capable of storing, encoding or carrying a set of instructions for execution by the
15 machine and that cause the machine to perform any one or more of the methodologies of the present disclosure. The term “machine-accessible non-transitory medium” shall accordingly be taken to include, but not be limited to, solid-state memories, optical and magnetic media, and carrier wave signals.

 Referring to Figure 13A (side view), an embodiment of a fluid application unit
20 1300 is illustrated in accordance with one embodiment. A tractor or other implement pulls multiple side dressing fertilizer coulter units (e.g., application unit 1300). The crop may be at a seedling stage when fertilizer is typically applied as a side dressing slightly offset laterally from each row of seedlings. Each application unit includes a frame 1310, a member 1316 for supporting a coulter wheel 1318 (e.g., single disc, double disc), a
25 member 1314 for supporting a shallow trench forming member 1342 (e.g., scratching knife 1342) for opening a shallow trench in the soil having a shallow depth (e.g., 0-4 inches, 0-2 inches, approximately 1 inch). The frame 1310 preferably includes an internal or externally mounted conduit (not shown) for applying a crop input (e.g., fluid crop input such as anhydrous or other fertilizer, nutrients, etc.) with a fluid outlet 1340
30 into the shallow trench. A covering tine 1330 (e.g., rake, closing wheel) closes the shallow trench to retain the crop input in the soil (or ground 1390). A spring pivot 1312 allows the member 1314 and fluid outlet 1340 to pivot with a range of motion 1315 with respect to the member 1316.

The frame 1310 may comprise an injection assembly (e.g., sidedress liquid fertilizer injection assembly or anhydrous injection assembly) such as those illustrated in FIG. 7 of U.S. Patent No. 5,890,445, incorporated herein by reference or in U.S. Patent No. 8,910,581, incorporated by reference. The frame 1310 and application unit 1300
5 can be used in combination with any other embodiments of the present disclosure. In one example, the feelers 820a, 820b and fluid outlets 830a, 830b of Figure 8 are used in combination with the frame 1310 and application unit 1300.

Figure 13B (top view) illustrates an embodiment of a liquid application unit 1350 having multiple trench forming members (e.g., knives) and fluid outlets in accordance
10 with one embodiment. A tractor or other implement pulls multiple side dressing fertilizer coulters (e.g., application unit 1350) for forming a trench having a depth (e.g., 4-8 inches, approximately 5-7 inches, etc.). The crop may be at a seedling stage when fertilizer is typically applied as a side dressing slightly offset laterally from each row of seedlings. Each application unit includes a frame (not shown), a coulters wheel
15 1318 for forming a deeper trench having a depth (e.g., 4-8 inches, approximately 5-7 inches, etc.), a trench forming member 1360 (e.g., scratching knife 1360) for opening a shallow trench having a shallow depth (e.g., 0-4 inches, 0-2 inches, approximately 1 inch) in proximity to a row of plants P-14, and a trench forming member 1362 (e.g.,
20 scratching knife 1362) for opening a shallow trench having a shallow depth (e.g., 0-4 inches, 0-2 inches, approximately 1 inch) in proximity to a row of plants P-15. The frame preferably includes an internal or externally mounted conduit (not shown) for applying a crop input (e.g., fluid crop input such as anhydrous or other fertilizer, nutrients, etc.) with fluid outlets 1371-1372 into a respective trench. Each knife may be
25 associated with a respective covering tine 1331-1332 (e.g., rake, closing wheel) for closing the shallow trench to retain the crop input in the soil (or ground) and prevent the crop input from being volatilized.

In another example, the knife 1342, fluid outlet 1340, and member 1314 may optionally be included with the application unit 1350, coupled to the member 1316, and have a lateral position that is approximately equidistant with respect to the rows of
30 plants P-14, P-15. The knife 1360 has a lateral position that is approximately within 5-10 inches of the plants P-14 while the knife 1362 has a lateral position that is approximately within 5-10 inches of the plants P-15. In this manner, crop input can be supplied at any desired location at any desired depth within approximately 5 inches of a row of plants. Any desired percentage of crop input can be applied to each fluid outlet

1340, 1371-1372 for optimal plant growth. In one example, a first percentage of a crop input is applied to the fluid outlet 1340 and a second percentage of a crop input is applied to the fluid outlets 1371 and 1372.

Where reference is made to a fluid/liquid as to any of the various embodiments disclosed herein, it should be appreciated that any fluid may be similarly transferred and applied by such embodiments; e.g., in a liquid, gaseous, dense phase or transitional phase.

For each of the fluid application unit embodiments described herein, multiple units are preferably disposed along the length of the bar, e.g., such that one, two or more rows of plants are disposed between each unit.

Figure 14 illustrates an adjustable bracket 1400 for coupling any of the frames described herein to a bar 10 in accordance with one embodiment. The bracket 1400 is preferably adjustable such that the frame (e.g., frames 310, 410, 510, 610, 710, 810, 910) of any of the embodiments disclosed herein may be mounted to any bar (e.g., bar 10) having variable size and cross-sectional shape. In the illustrated embodiment, a rotating member 1432 (e.g., dial 1432) may be manipulated or rotated by the installer to adjust a position of a retaining member 1434 in order to retain the bracket 1400 on bars 10 having various widths. In the illustrated embodiment the bracket 900 includes two separable portions 1440, 1450 which may be separated for installation and then secured to one another such as by bolts (not shown). The frame 1410 may be fixed to the bracket 1400 by U-bolts 1412a, 1412b and/or by any quick coupling structure known in the art.

Figure 15A illustrates an isometric view of an application unit 1500 in accordance with one embodiment. The application unit 1500 is preferably mounted to a transversely extending bar 10 (e.g., toolbar or boom) drawn by a tractor or other implement. A frame 1510 (e.g., rigid frame 1510) is coupled to the bar 10, a frame 1511 (flexible frame, rigid frame), and a base 1512. It should be appreciated that frame 1510 and 1511 could be a unitary part. The base 1512 includes a biasing element 1513 (e.g., spring) to bias or position linkage members 1520a, 1520b outwards towards rows of plants P-16, P-17. The base 1512 also includes pins 1514a, 1514b positioned in holes to set a width for biasing of the linkage members for different crop row spacing. The base 1512 includes additional holes 1515a, 1515b and 1516a, 1516b to reduce a width of the linkage members 1520a, 1520b to adjust for different crop row spacing or for different types of crops. For a turn of a tractor and an implement having a plurality of application units

1500, the biasing element and pins cause the flexible members to flex inwards. Optionally, a rotating swivel 1570 or 1571 can be disposed between bar 10 and frame 1510 and/or between frame 1511 and base 1512. The degree of rotation can be any desired degree, but actual rotation will be limited by the movement in the rows. Having
5 a rotating swivel 1570 or 1571 provides more flexibility during use to keep application unit 1500 in the row without providing too much force on the plants.

The biasing element 1513 biases angular positions of the first and second linkage members 1520a and 1520b such that distal ends 1521a, 1521b of the linkage members have a spacing 1525 that is similar to a row spacing of the rows of plants P-
10 16, P-17.

In another embodiment, biasing element 1513 can be replaced with a pressure actuated biased return pistons 1540a and 1540b shown in an isometric view of an application unit 1532 in Figure 15B. Pressure actuated biased return pistons 1540a and 1540b are oppositely disposed and coupled with a coupler 1541, which has a fluid inlet
15 1542 for supplying pressure to pressure actuated biased return pistons 1540a and 1540b through the coupler 1541. The pistons in the pressure actuated biased return pistons 1540a and 1540b are in communication with pivots 1543a and 1543b, respectively, disposed on base 1512 at the edges of base 1512. Pivots 1543a and 1543b are disposed on base 1512 via pins 1544a and 1544b, respectively. Linkage
20 members 1520a and 1520b are disposed on pivots 1543a and 1543b, respectively. Linkages 1520a and 1520b have fluid inlets 1520-1a and 1520-1b, respectively, and are in fluid communication with the fluid system. Pressure actuated biased return pistons 1540a and 1540b connect to pivots 1543a and 1543b between pins 1544a and 1544b and base edge 1512a. As shown in Figure 15B, pressure actuated biased return
25 pistons 1540a and 1540b are directly connected to pivots 1543a and 1543b, respectively, but they could also be connected through optional pivot connections 1545a and 1545b, respectively, similar to connectors 1705a and 1705b in Figure 17A.

Similar to as shown in Figure 15B for the pressure actuated biased return pistons that are similar to the pressure actuated biased return pistons in Figure 17A, any of the
30 embodiments in Figures 17D to 19C can also be disposed on base 1512.

The fluid to drive the pistons can be from the fluid, or it can be from a pneumatic or hydraulic system on the toolbar (not shown). With the fluid system, when fluid is applied, the pressure in the fluid system will cause the pressure actuated biased return pistons 1540a and 1540b to bias outwards to the edge of base 1512. When the fluid

application is turned off, the biased return in the pressure actuated biased return pistons 1540a and 1540b will bias the piston toward the middle of base 1512. For the pneumatic or hydraulic system, these can be activated manually or automatically when the fluid system is turned on.

5 The benefit of having the dual direction biasing is that the linkage members 1520a and 1520b will bias outwards towards the plants during fluid application, and will bias toward the middle of the row when the fluid system is not on. By having the linkage members 1520a and 1520b bias toward the middle of the row, application unit (e.g., 1500, 1532, etc.) can be reversed down the row. This can be helpful when steering
10 causes misalignment in a row, and the application unit (e.g., 1500, 1532) needs to back up to correct the steering. If linkage members 1520a and 1520b are always biased towards the plants, they would catch and fold over the plants if run in a reversed direction.

 The linkage members 1520a, 1520b are coupled to flexible members 1522a,
15 1522b respectively. In one example, the linkage members position the flexible members 1522a, 1522b in close proximity to a target region of the plants. The flexible members 1522a, 1522b can be any type of flexible material (e.g., hoses) or can be replaced with pipes. It should be appreciated that linkage members 1520a, 1520b and flexible members 1522a, 1522b, respectively, can be made as unitary parts. In one
20 example, these components of the application unit 1500 function in a similar manner in comparison to the frame, base, linkage members, and flexible members of the application unit 1000 with the ground contacting members 1524a, 1524b (e.g., ski, skid, wear element, etc.) at least partially contacting the ground while in operation with the application unit 1500 moving in a direction D that is substantially parallel with respect to
25 rows of plants P-16 and P-17. The ground contacting members 1524a, 1524b substantially prevent the flexible members 1522a, 1522b from contacting the ground and thus reduce wear on the flexible members 1522a, 1522b. The ground contacting members 1524a, 1524b also position the flexible members 1522a, 1522b to be slightly elevated (e.g., 0 to 3 inches) above the ground.

30 Fluid outlets 1530a, 1530b (e.g., spray nozzle, drip mechanism) are positioned with respect to a distal portion 1528a, 1528b of flexible members 1522a, 1522b for spraying a fluid in close proximity to the plants. In one example, the fluid outlets are positioned at a distal end of the distal portions of the flexible members and generate a spray Sa, Sb that sprays in a downward direction towards a base region of plants P-16,

P-17, respectively. It should be appreciated that each fluid outlet in the various embodiments described herein is preferably in fluid communication with a source (e.g., tank 250) containing an application (e.g., fluid application, crop inputs such as fertilizer, fungicide, herbicide or insecticide).

5 In another embodiment, the application unit 1500 optionally includes a housing member 1580 for positioning a plurality of fluid outlets (e.g., 1581-1585) at a plurality of different angles (e.g., angled down towards ground, angle outwards from the housing member 1580) having a maximum range of approximately 180 degrees. Additional or fewer fluid outlets can be positioned with the housing member 1580. Each fluid outlet
10 can have a fixed position or an adjustable angular position for spraying a fluid towards a base region of the plants or towards a certain target region between the rows of plants P-16, P-17. The fluid sprayed by the fluid outlets 1581-1585 can be the same fluid that is spraying by the fluid outlets 1530a, 1530b or this fluid can be different. In one example, the fluid outlets 1581-1585 spray a fungicide.

15 The frame (e.g., 1510, 1511), base, linkage members, and flexible members preferably include an internal or externally mounted conduit (not shown) for applying a crop input (e.g., fluid crop input such as anhydrous or other fertilizer, nutrients, etc.) towards a target region of the plants or into trenches. The frame may comprise an injection assembly (e.g., sidedress liquid fertilizer injection assembly or anhydrous
20 injection assembly) such as those illustrated in FIG. 7 of U.S. Patent No. 5,890,445, incorporated herein by reference or in U.S. Patent No. 8,910,581, incorporated by reference; the fluid outlets, as well as related linkage structure are preferably fixed to the sides of such an injection assembly for spraying or dribbling a liquid on nearby plants or towards a target region of the plants.

25 Figure 16 illustrates an isometric view of an application unit 1600 positioned in proximity to rows of plants in accordance with one embodiment. The application unit 1600 includes similar components and functionality in comparison to the application unit 1500 of Figure 15. The application unit 1600 is preferably mounted to a transversely extending bar 10 (not shown in Figure 16) drawn by a tractor or other implement. A
30 frame 1610 (e.g., 1510, 1511) is coupled to the bar 10, and a base 1612. The base 1612 includes a biasing element 1613 (e.g., spring) to bias or position linkage members 1620a, 1620b outwards towards rows of plants P-18, P-19. The linkage members 1620a, 1620b are coupled to flexible members 1622a, 1622b respectively. The flexible members can be any type of flexible material (e.g., hoses) or can be replaced with

pipes. In one example, the ground contacting members 1624a, 1624b (e.g., ski, skid, wear element, etc.) at least partially contact the ground 1690 while in operation with the application unit 1600 moving in a direction D that is substantially parallel with respect to rows of plants P-18 and P-19. The ground contacting members 1624a, 1624b

5 substantially prevent the flexible members 1622a, 1622b from contacting the ground and thus reduce wear on the flexible members 1622a, 1622b. The ground contacting members 1624a, 1624b also position the flexible members 1622a, 1622b to be slightly elevated (e.g., 0 to 3 inches) above the ground.

Fluid outlets 1630a, 1630b (e.g., spray nozzle, drip mechanism) are positioned

10 with respect to a distal end of flexible members for spraying a fluid in close proximity to the plants. In one example, the fluid outlets generate spray Sa, Sb that sprays in a downward direction towards a base region of plants P-18, P-19, respectively. It should be appreciated that each fluid outlet in the various embodiments described herein is preferably in fluid communication with a source (e.g., tank 250) containing an

15 application (e.g., fluid application, crop inputs such as fertilizer, fungicide, herbicide or insecticide).

Figure 17A illustrates an isometric view of an application unit 1700 for mounting to a coulter fertilizer disc 1790. Coulter fertilizer disc 1790 has a toolbar arm 1799 for connection to bar 10. Attached to toolbar arm 1799 is a bracket 1793 for connecting

20 coulter mounting arm 1792. At the opposing end, disc 1791 is mounted to coulter mounting arm 1792 along with blade mounting arm 1794 disposed rearward of the direction of travel of coulter fertilizer disc 1790. Connected to blade mounting arm 1794 is a blade 1795 (or a sprayer not shown) with fluid line 1796. Application unit 1700 has a bracket 1701 (generally shown with a U shape) that connects to where blade 1795 (or

25 sprayer) connects to blade mounting arm 1794 with a closed end of the bracket 1702 forward of disc 1791. Application unit 1700 is used in conjunction with the embodiments of Figures 17B to 19C below, which show application unit 1700 in partial.

Disposed near closed end of the bracket 1702 are pivots 1703a and 1703b that are disposed on bracket 1701 through pins 1704a and 1704b, respectively as illustrated

30 in isometric view 1750 of Figure 17B and side view 1752 of Figure 17C in accordance with one embodiment. Actuating the pivots 1703a and 1703b are pressure actuated biased return pistons 1710a and 1710b, respectively. Pressure actuated biased return pistons 1710a and 1710b can directly connect to pivots 1703a and 1703b as shown in Figure 15B for pressure actuated biased return pistons 1540a and 1540b to pivots

1543a and 1543b. Alternatively, pressure actuated biased return pistons 1710a and 1710b can connect through piston arms 1708a and 1708b, respectively, and connectors 1705a and 1705b, respectively, to pivots 1703a and 1703b, respectively. In either embodiment, the connection on the side of the pins 1704a and 1704b is away from
5 closed end of the bracket 1702. Disposed between pressure actuated biased return pistons 1710a and 1710b is a coupler 1711 having a fluid inlet 1712. Connected to pivots 1703a and 1703b are linkages 1720a and 1720b, respectively. Linkages 1720a and 1720b (e.g., arms) have fluid inlets 1721a and 1721b, respectively, and are in fluid communication with the fluid system.

10 The fluid to drive the pistons is described above for application unit 1500.

Figure 17D illustrates an isometric view of an application unit 1780 in accordance with another embodiment. This application unit 1780 includes similar components in comparison to the components of application unit 1750 of Figure 17B, except that linkage members 1520a' and 1520b' include distal portions that curve inwards towards
15 each other. Any of the other embodiments discussed herein may also have linkage members 1520a and 1520b having a similar inwards curvature.

In other alternatives shown in Figures 18A and 18B, the fluid actuation with the pressure actuated biased return pistons 1710a and 1710b are replaced by solenoids 1810a and 1810b, which are disposed on bracket 1702 via brackets 1811a and 1811b,
20 respectively, as illustrated in application unit 1800 of Figure 18A. Solenoids 1810a and 1810b are activated by an electrical switch (not shown). In place of solenoids 1810a and 1810b can be electric motors 1820a and 1820b, respectively, as illustrated in application unit 1850 of Figure 18B.

In other alternatives shown in linkage systems 1990-1992 of Figures 19A to 19C,
25 respectively, the fluid actuation with the pressure actuated biased return pistons 1710a and 1710b are replaced by linkage system 1990, which is disposed on bracket 1702 via bracket 1960. Linkage system 1990 has an actuator 1951 in communication with gear box 1950 for acting on linkage arms 1952a and 1952b. Linkage arms 1952a and 1952b are connected to connectors 1705a and 1705b, respectively, or directly to pivots 1703a
30 and 1703b, respectively (not shown). Actuator 1951 can be actuated by solenoid 1910 in Figure 19A or electrical motor 1920 of linkage system 1991 in Figure 19B, which are disposed on bracket 1702 via bracket 1911. Solenoid 1910 and electrical motor are activated by an electrical switch (not shown). Alternatively, actuator 1951 can be actuated by ground contacting arm 1940 of linkage system 1992 as illustrated in Figure

19C. When ground contacting arm 1940 contacts the ground, ground contacting arm causes pivot 1941 to pivot and actuate actuator 1951.

The linkage members (arms) discussed herein can be actuated with solenoids, electrical motors, or via a linkage using at least one solenoid, motor, or ground contact.

5 The electrical switch in the above embodiments can be a separate switch activated by an operator when coulter fertilizer disc 1790 is lowered to the ground, or the electrical switch can be activated when the coulter fertilizer disc 1790 is commanded to be lowered. Alternatively, the electrical switch can be activated by ground contact.

10 The following examples pertain to further embodiments. Specifics in the examples may be used anywhere in one or more embodiments.

For example, in one embodiment, an application unit includes a frame to be positioned in operation between first and second rows of plants, a first plant contacting member being pivotally coupled to the frame in operation such that the first plant contacting member to be deflected rearwardly with respect to a direction of motion of the frame upon the first plant contacting member contacting at least one of the plants of the first row of plants which causes a first change in orientation of the first plant contacting member with respect to the frame. A first outlet applies a fluid application to the first row of plants with the first outlet being mechanically linked to the first plant contacting member. The first change in orientation causes a corresponding second change in orientation of the first outlet with respect to the frame.

15 In another example, the application unit further includes a second plant contacting member being pivotally coupled to the frame in operation such that the second plant contacting member to be deflected rearwardly with respect to the direction of motion of the frame upon the second plant contacting member contacting at least one of the plants of the second row of plants which causes a third change in orientation of the second plant contacting member with respect to the frame. A second outlet applies a fluid application to the second row of plants with the second outlet being mechanically linked to the second plant contacting member. The third change in orientation causes a corresponding fourth change in orientation of the second outlet with respect to the frame.

25 In another embodiment, an application unit includes a frame to be positioned in operation between two rows of plants and a base member coupled to the frame. The base member to be positioned in proximity to a ground surface while in operation. First and second plant guidance members are coupled to the base member in operation such

that the first and second plant guidance members guide a lateral position of the base member to be approximately equidistant from the two rows of plants based upon whether at least one of the first and second plant guidance members contacts one or more plants of the two rows of plants.

5 In one example, the application unit further includes first and second outlets coupled to the base member in operation such that a change in lateral position of the base member causes a corresponding change in position of the first and second outlets for applying a fluid application to the plants.

In another embodiment, a closer 2010 or closer 2020 can be disposed after
10 coulter fertilizer disk 1790 in a direction of travel DT of the coulter fertilizer disk 1790. Different embodiments of closer 2010 are illustrated in Figures 20A to 20F, and closer 2020 is illustrated in Figures 21A to 21B. Figure 20A is a side elevation view of a closer on a coulter wheel according to one embodiment. Figure 20B is a rear view of the closer of Figure 20A according to one embodiment in which the top and bottom of the arms are
15 equidistant to the axis through the trench and the front and back of the arms are equidistant to the axis through the trench. Figure 20C is a rear view of the closer of Figure 20A according to one embodiment in which the bottom of the arms are closer to the axis through the trench than the top of the arms. Figure 20D is a rear view of the closer of Figure 20A according to one embodiment in which the back of the arms are
20 closer to the axis through the trench than the front of the arms.

Figure 20E is a rear view of the closer of Figure 20A according to one embodiment in which the bottom of the arms are closer to the axis through the trench than the top of the arms and the back of the arms are closer to the axis through the trench than the front of the arms. Figure 20F is a side view of the closer of Figure 20B
25 according to one embodiment in which the bottom of the arm is at least partially disposed behind the top of the arm in a direction of travel.

Figure 21A is a side elevation view of an alternative closer disposed on a blade according to one embodiment.

Figure 21B is a rear elevation view of the blade and closer of Figure 21A.

30 The embodiments of closer 2010 or closer 2020 can all be used with the embodiment illustrated in Figure 17A, which further includes blade 1795. Closer 2010 or closer 2020 can be disposed behind blade 1795 of Figure 17A in a direction of travel DT of the coulter fertilizer disk 1790 by attachment to blade mounting arm 1794 or

attachment to blade 1795. Also, blade 1795 from Figure 17A can be disposed on mounting arm 2005 instead of blade mounting arm 1794.

Closer 2010 has a top bar 2011 and at least one arm 2012 disposed downwardly from top bar 2011. Top bar 2011 can be disposed on mounting arm 2005 by any
 5 suitable attachment, such as welding, bolting, or riveting. Top bar 2011 can be generally horizontal, and extends transversely across a trench T created by disk 1791 and/or blade 1795. In one embodiment, there can be two arms 2012-1 and 2012-2 disposed on top bar 2011 as illustrated in Figure 20B.

Arm 2012 has a top edge 2012t, a bottom edge 2012b, a front edge 2012f, and a
 10 back edge 2012bk. Arm 2012 (or arms 2012-1 and 2012-2 having the same top edge 2012t-1, 2012t-2; bottom edge 2012b-1, 2012b-2; front edge 2012f-1, 2012f-2; and back edge 2012bk-1, 2012bk-2) can be disposed according to one or more of the following configurations with respect to an axis through trench T along a direction of travel DT of
 coulter fertilizer disk 1790: the bottom edge 2012b (2012b-1, 2012b-2) and the top edge
 15 2012t (2012t-1, 2012t-2) are equidistant to the axis (illustrated in Figure 20B); the bottom edge 2012b (2012b-1, 2012b-2) is closer to the axis than the top edge 2012t (2012t-1, 2012t-2) (illustrated in Figure 20C); the back edge 2012bk (2012bk-1, 2012bk-2) is closer to the axis than the front edge 2012f (2012f-1, 2012f-2) (illustrated in Figure
 20 20D); both the bottom edge 2012b (2012b-1, 2012b-2) is closer to the axis than the top edge 2012t (2012t-1, 2012t-2) and the back edge 2012bk (2012bk-1, 2012bk-2) is closer to the axis than the front edge 2012f (2012f-1, 2012f-2) (illustrated in Figure 20E); or the bottom edge 2012b (2012b-1, 2012b-2) is disposed at least partially behind the
 top edge 2012t (2012t-1, 2012t-2) along a direction of travel DT (illustrated in Figure
 20F using the embodiment from Figure 20B. While illustrated with the embodiment from
 25 Figure 20B, the embodiment from Figure 20F can be used with any of the embodiments illustrated in any of Figures 20C, 20D, and 20E.

As illustrated in Figures 21A and 21B, closer 2010 can be replaced with closer
 2020. In this embodiment, closer 2020 is disposed on blade 1795. Closer 2020 has a
 planer shape and a width that extends over the trench T created by disk 1791. As
 30 coulter fertilizer disk 1790 traverses a field and creates a trench T, closer 2020 levels soil displaced by disk 1791 and/or blade 1795.

As shown, closer 2010 or closer 2020 is connected to mounting arm 2005 or
 knife 1795, respectively. Alternative, closer 2010, closer 2020 can be connected to bar
 10 by a mounting arm (not shown).

Figures 22A and 22B illustrate a nozzle 3000 that can be disposed at the end of the fluid lines described herein (such as flexible member 922, flexible member 982, flexible member 1022, flexible member 1522, linkage member 1520, or fluid outlets 1530). Fluid line 3010 is connected to a nozzle housing 3021. Nozzle housing 3021
5 has a nozzle 3022 disposed opposite to the fluid line 3010. Nozzle housing 3021 and nozzle 3022 can be a unitary part or separate parts. Nozzle 3022 has an outlet 3023 disposed in nozzle 3022 for dispensing fluid. As shown, outlet 3023 is disposed downward towards the ground. Also, outlet 3023 can be disposed on the side facing
10 towards plants (not shown). Outlet 3023 can optionally have an aerator 3025 disposed in itself to regulate the flow fluid. Nozzle housing 3021 further includes a ski 3030 (such as a spring wire) disposed through nozzle housing 3021 and extending backward away from nozzle housing 3021 for engaging the ground to keep the nozzle outlet 3023 from contacting the ground to improve fluid flow.

Figure 23 illustrates a flexible member 3050 that includes a reinforcement 3051
15 disposed on or in flexible member 3050. This embodiment can be used with any flexible member described herein (such as flexible member 922, flexible member 982, flexible member 1022, or flexible member 1522). An unreinforced flexible member, such as a hose, can flop around while being drawn through a field. This can cause fluid to not be dispensed in the selected area. Reinforcement 3051 can add stiffness to
20 flexible member 3050 and to keep flexible member 3050 biased against plants. In one embodiment, reinforcement 3051 is a wire.

Illustrated in Figures 24A and 24B are cradles 3100a, 3100b, which can be used to hold members 3110a, 3110b (such as flexible member 922, flexible member 982, flexible member 1022, flexible member 1522, linkage member 1520, or fluid outlets
25 1530) when used in conjunction with any of the application units 1700, 1750, 1752, 1780, 1800, 1850, or 1992 as illustrated in Figures 17A to 19C. When disk 1791 is raised for transport, members 3110a, 3110b will tend to drag towards the ground under the pull of gravity. Cradles 3100a, 3100b can be disposed on bracket 1701 transverse to the direction of travel. Members 3110a, 3110b can be stored in cradles 3100a,
30 3110b, respectively. Optionally, members 3110a, 3110b are latchable in cradles 3100a, 3100b with latches 3101a, 3101b, respectively, which are hingably engaged with cradles 3100a, 3100b, respectively. Side a is illustrated, but side b has the same configuration on the other side.

Figure 25 illustrates an application unit 3200 as an alternative embodiment for application unit 1500 illustrated in Figure 15A. Base 1512 is replaced with base 3212, and linkage members 1520a, 1520b are replaced by linkage members 3220a, 3220b, respectively. Linkage members 3220a, 3220b are pivotally connected to base 3212
5 through pivots 3201a, 3201b, respectively. Linkage members 3220a, 3220b have a portion 3221a, 3221b that extend forward of base 3212 in a direction of travel. Base 3212 has walls 3202a, 3202b extending forward of base 3212 in a direction of travel. Biasing members 3203a, 3203b (such as a spring) are disposed between walls 3202a, 3202b and portions 3221a, 3221b, respectively, to bias portions 3221a, 3221b away
10 from walls 3202a, 3202b so that flexible members 3222a, 3222b are biased towards the plants.

Figure 26 illustrates an embodiment in which a flexible member 3322 (such as flexible member 922, flexible member 982, flexible member 1022, or flexible member 1522) has a spring 3303a, 3303b disposed over flexible member 3322 (e.g., 3322a,
15 3322b) proximate to the end opposite of the discharge of flexible member 3322. Spring 3303 can be the only biasing in the application unit, or spring 3303 can be used with any other biasing described herein. Components of the nozzle 3000 of Figure 22A are coupled to the flexible member 3322a and 3322b. The nozzle 3000 includes fluid line 3010 (e.g., 3010a, 3010b) that is connected to a nozzle housing 3021 (e.g., 3021a,
20 3021b). Nozzle housing 3021 has a nozzle 3022 (e.g., 3022a, 3022b) disposed opposite to the fluid line 3010. Nozzle housing 3021 and nozzle 3022 can be a unitary part or separate parts. Nozzle 3022 has an outlet 3023 (e.g., 3023a, 3023b) disposed in nozzle 3022 for dispensing fluid. As shown, outlet 3023 is disposed downward towards the ground. Also, outlet 3023 can be disposed on the side facing towards
25 plants. Outlet 3023 can optionally have an aerator 3025 disposed in itself to regulate the flow fluid (not shown).

Figures 27A to 27G illustrate another embodiment for an application unit 2700. Application unit 2700 is connected to a vertical support 2799, which is connected to a transversely extending bar 10 (e.g., toolbar or boom) drawn by a tractor or other
30 implement. Vertical support 2799 can have a length such that application unit 2700 is disposed at the bottom of vertical support 2799 proximate to the ground. An optional coulter assembly 2780 can also be connected to vertical support 2799 posterior to application unit 2700 in a direction of travel. In one embodiment that does not include coulter assembly 2780, vertical support 2799 can have a length so that application unit

2700 is proximate to the ground. Or vertical support 2799 can have a length that extends to where coulter assembly 2780 attaches, and application unit 2700 attaches to vertical support proximate to where coulter assembly attaches. Even when coulter assembly 2780 is not included, there is an advantage to having application unit 2700
5 disposed above the ground and not proximate to the ground to avoid having application unit 2700 from impacting the ground as contoured terrain is encountered.

Application unit 2700 includes a bracket 2701 for connecting to vertical support 2799. Connected to bracket 2701 is a pivot 2705 having a vertical axis to permit application unit 2700 to pivot in a horizontal plane. This allows application unit 2700 to
10 freely pivot to provide self-alignment between adjacent rows of plants in the event that application unit 2700 is not centered between the rows during operation. Optionally, a deflector 2710 is disposed on the front of application unit 2700 in the direction of travel. Deflector 2710 is connected via a deflector bracket 2711 to bracket 2701. In one embodiment, deflector bracket 2711 has arms 2712a, 2712b, which can be a unitary
15 part or separate parts.

The description below is for both sides of application unit 2700. For clarity, one side of application unit is illustrated in the drawings. It is understood, that the same parts are also disposed on the other side of application unit 2700.

Disposed below pivot 2705 is bracket base 2702. Pivotaly connected to bracket
20 base 2702 is bracket assembly 2740 (2740a, 2740b) through pivot 2747 (2747a, 2747b) on a horizontal axis to permit vertical rotation of bracket assembly 2740 (2740a, 2740b). Pivotaly connected to bracket assembly 2740 (2740a, 2740b) is bracket assembly 2730 (2730a, 2730b) through pivot 2737 (2737a, 2737b) to permit rotation transverse to the direction of travel.

Bracket assembly 2730 (2730a, 2730b) has a bracket base 2731 (2731a,
25 2731b). Connected to bracket base 2731 (2731a, 2731b) is a fluid arm 2720 (2720a, 2720b). Connected to fluid arm 2720 (2720a, 2720b) is a fluid line 2722 (2722a, 2722b), which is fluid communication with a fluid source (e.g., tank 250). Bracket base 2731 (2731a, 2731b) is biased outward by bias element 2735 (2735a, 2735b). Bias
30 element 2735 (2735a, 2735b), such as a spring, is disposed over element 2734 (2734a, 2734b), which is connected to a bracket 2732 (2732a, 2732b), which is connected to bracket base 2741 (2741a, 2741b). Element 2734 (2734a, 2734b) is disposed through a bracket 2733 (2733a, 2733b). Bias element 2735 (2735a, 2735b) is disposed over

element 2734 (2734a, 2734b) between a stop 2736 (2736a, 2736b) and a side of bracket 2733 (2733a, 2733b) away from bracket 2732 (2732a, 2732b).

Bracket assembly 2740 (2740a, 2740b) includes a bracket base 2741 (2741a, 2741b). Bias element 2745 (2745a, 2745b), such as a spring, is disposed over element
5 2744 (2734a, 2744b), which is connected to a bracket 2742 (2742a, 2742b), which is connected to bracket base 2741 (2741a, 2741b). Element 2744 (2744a, 2744b) is disposed through a bracket 2709, which is connected to bracket base 2702. Bias element 2745 (2745a, 2745b) is disposed over element 2744 (2744a, 2744b) between a
10 stop 2746 (2746a, 2746b) and a side of bracket 2709 away from bracket 2742 (2742a, 2742b). Optionally, as illustrated in Figure 27G, bias element 2748 (2748a, 2748b) is disposed over element 2744 (2744a, 2744b) on a side of bracket 2709 opposite to biasing element 2745 (2745a, 2745b). Balancing the amount of bias between bias element 2745 (2745a, 2745b) and bias element 2748 (2748a, 2748b) can determine the amount of down rotation.

15 As illustrated, application unit 2700 has two degrees for biasing fluid arms 2720a, 2720b outward and down. In another embodiment, such as when application unit 2700 is disposed proximate to the ground, down biasing is not needed. In this embodiment, bracket assembly 2730 (2730a, 2730b) is pivotally connected to bracket base 2702, bracket 2732 (2732a, 2732b) is connected to bracket base 2702, and bracket assembly
20 2740 (2740a, 2740b) and member 2709 are not included (not shown).

Optionally, disposed on the discharge end of fluid arms 2720a, 2720b is nozzle 3000. In one embodiment, the rotation of fluid arms 2720a, 2720b outward towards the plant transverse to the direction of travel can be limited by stop 2721 (2721a, 2721b), which is disposed on bracket base 2741 (2741a, 2741b) to limit the rotation of bracket
25 base 2731 (2731a, 2731b). In another embodiment, a tab 2704 is disposed on the underside of bracket 2701. A stop 2703, which can have a U shape, is connected to bracket base 2702, and which limits the rotation of application unit 2700 when tab 2704 contacts stop 2703. In another embodiment, counteracting forces from bias element 2738 (2738a, 2738b) can limit the rotation of bracket base 2731 (2731a, 2731b) by
30 being disposed over element 2734 (2734a, 2734b) on a side of bracket 2733 (2733a, 2733b) opposite to biasing element 2735 (2735a, 2735b). In one embodiment illustrated in Figure 27C, nozzle 3022 does not contact the plants, and the contact is made by ski 3030a, 3030b.

Optionally, coulter assembly 2780 can be connected to vertical support 2799. Coulter bracket arm 2781 is connected to vertical support 2799 at a first end, and at the opposite end, coulter 2782 is rotationally connected to coulter bracket arm 2781. Optionally, an extension arm 2783 is connected to coulter bracket arm 2781 and
5 disposed rearwardly along a direction of travel. A knife 2784 is disposed downwardly from extension arm 2783 to engage the ground posterior to coulter 2782. Optionally, a fluid application line 2785 is disposed on knife 2784 for depositing fluid into the ground. As shown, application line 2785 is disposed on the posterior side of knife 2784 in the direction of travel, but application line 2785 can be disposed on any side of knife 2784.

10 Optionally, a cradle 2770 can be connected to bracket 2701 and disposed rearwardly in the direction of travel. Cradle 2770 has arms 2771a, 2771b and each has a receiver 2772a, 2772b, respectively (with an opening disposed upwards) for holding and retaining arms, respectively, when not in use, such as during transport. Arms 2771a, 2771b can be made as a unitary part or separate parts.

15 In addition to any of the application units described above, at least one sprayer may be further included. An example of a sprayer can be found in US20170049043, which is incorporated herein by reference.

In another embodiment, dampers can be included to dampen the motion of any member that contact plants. Examples of members include parts 922, 982, 1522, 1528,
20 1520, 1720, 3030, and 3110. In any of the embodiments illustrated in Figures 28A to 28D, the fluid application members are in fluid communication with a fluid source (not shown).

Illustrated in Figure 28A, application unit 2891 includes a base 2812 with fluid application member 2805 (2805a, 2805b) for dispensing fluid. Damper 2861 (2861a,
25 2861b), such as a coil spring, is disposed about fluid application member 2805. Plant contacting member 2851 (2851a, 2851b) is connected to and extends from damper 2861 to contact plants. Plant contacting member 2851 can be a wire. Vibrations in plant contacting member 2851 are dampened by damper 2861.

Illustrated in Figure 28B, application unit 2892 includes base 2812 with fluid
30 application member 2806 (2806a, 2806b) for dispensing fluid. Connected to fluid application member 2806 is a plant contacting member 2830 (2830a, 2830b) for extending to and contacting plants. Disposed between plant contacting member 2830 and fluid application member 2806 is a damper 2862 (2862a, 2862b) for dampening

vibrations caused by plant contacting member 2830 contacting plants. Examples of damper 2862 include, but are not limited to, shock absorber and dashpot.

Illustrated in Figure 28C, application unit 2893 includes a base 2812 with fluid application member 2807 (2807a, 2807b) that extend from base 2812 to deliver fluid and contact plants. Connected to base 2812 and disposed to contact fluid application member 2807 is damper 2862 (2862a, 2862b).

Illustrated in Figure 28D, application unit 2894 includes a base 2812 and linkage member 2820 (2820a, 2820b) for conveying fluid. Connected to linkage member 2820 is fluid application member 2822 (2822a, 2822b). Fluid application member can be a hose. Attached to fluid application member 2822 and extending to and contacting plants is plant contacting member 2851 (2851a, 2851b). Plant contacting member 2851 can be a wire or other flexible material. Connected to base 2812 and disposed to contact plant contacting member 2851 is damper 2862 (2862a, 2862b).

In another embodiment, with or without the damper, any of members that contact plants (such as 922, 982, 1522, 1528, 1520, 1720, 2851, 2830, 2807, 3030, 3110) have a length such that the member is in contact with at least two plants. Being in contact with at least two plants minimizes the outward flexing of the member.

While not shown, it is understood that any application unit described herein is in fluid communication with a source (e.g., tank 250) containing an application (e.g., fluid application, crop inputs such as fertilizer, fungicide, herbicide or insecticide).

Any of the following examples can be combined into a single embodiment or these examples can be separate embodiments. In one example, a fluid applicator (e.g., application unit 800, 850, 900, 1300, 1350, 1700, 1750, 1752, 1780, 2891-2894, etc.) for applying fluid to plants in rows in a field comprises a frame, a coulter connected to the frame and disposed to open a trench between the rows of plants, and at least one application member (e.g., 830, 920, 1520, 1720, 2805-2807, etc.).

In another example, the at least one application member comprises a first application member and a second application member.

In another example, the fluid applicator of further comprises a fluid application line connected to the frame and disposed behind the coulter in a direction of travel to apply fluid to the trench.

In another example, the coulter has coulter frame, and further comprising an extending frame connected to the coulter frame and disposed to extend behind the

coulter in a direction of travel, and a knife downwardly disposed from the extending frame and disposed to contact ground.

In another example, the fluid applicator further comprises a fluid application line connected to the knife to apply fluid in the trench.

5 In another example, the frame is a toolbar.

In another example, the frame is a boom.

In another example, the at least one application member is connected to the frame.

10 In another example, the coultter has coultter frame, and the at least one application member is connected to the coultter frame.

In another example, the fluid applicator further comprises a closer connected to the coultter and disposed to close the trench.

15 In one example, an application unit for applying fluids to plants in rows in a field comprises a frame, an opening disc connected to the frame and disposed to open a trench between the rows of plants, and at least one application member connected to the frame or to the coultter and disposed to apply fluid to a rhizosphere of the plants.

In another example, the at least one application member comprises a first application member and a second application member.

20 In another example, the application unit further comprises a fluid application line connected to the frame and disposed behind the opening disc in a direction of travel to apply fluid to the trench.

25 In another example, the opening disc has a frame, and the application unit further comprises an extending frame connected to the frame and disposed to extend behind the opening disc in a direction of travel, and a knife downwardly disposed from the extending frame and disposed to contact ground.

30 In one example, a fluid applicator, comprises a base disposed between plants in adjacent rows, at least one application member connected to the base and disposed to apply fluid to the plants in a rhizosphere of the plants, and a nozzle (e.g., 1530, 1630, 3000, etc.) disposed at an end of the application member for dispensing fluid from the application member to the plants in the rhizosphere of the plants.

In another example, the at least one application member comprises a first application member with a first nozzle and a second application member with a second nozzle.

In another example, the nozzle further comprises a wire extending from the nozzle and disposed to contact the plant.

In another example, the nozzle further comprises a ski disposed under the nozzle.

5 In another example, the nozzle further comprises an aerator.

In another example, the aerator is disposed on a bottom of the nozzle.

10 It is to be understood that the above description is intended to be illustrative, and not restrictive. Many other embodiments will be apparent to those of skill in the art upon reading and understanding the above description. The scope of the disclosure should, therefore, be determined with reference to the appended claims, along with the full scope of equivalents to which such claims are entitled.

CLAIMS

What is claimed is:

1. A fluid applicator for applying fluids to plants in rows in a field comprising:
a frame;
a coulter connected to the frame and disposed to open a trench between the rows of plants; and
at least one application member connected to the frame or to the coulter and disposed to apply fluid to a rhizosphere of the plants.
2. The fluid applicator of claim 1, wherein the at least one application member comprises a first application member and a second application member.
3. The fluid applicator of claim 1 further comprising a fluid application line connected to the frame and disposed behind the coulter in a direction of travel to apply fluid to the trench.
4. The fluid applicator of claim 1, wherein the coulter has coulter frame, and further comprising an extending frame connected to the coulter frame and disposed to extend behind the coulter in a direction of travel, and a knife downwardly disposed from the extending frame and disposed to contact ground.
5. The fluid applicator of claim 4 further comprising a fluid application line connected to the knife to apply fluid in the trench.
6. The fluid applicator of claim 1, wherein the frame is a toolbar.
7. The fluid applicator of claim 1, wherein the frame is a boom.
8. The fluid applicator of claim 1, wherein the at least one application member is connected to the frame.

9. The fluid applicator of claim 1, wherein the coulter has coulter frame, and the at least one application member is connected to the coulter frame.
10. The fluid applicator of claim 1 further comprising a closer connected to the coulter and disposed to close the trench.
11. An application unit for applying fluids to plants in rows in a field comprising:
 - a frame;
 - an opening disc connected to the frame and disposed to open a trench between the rows of plants; and
 - at least one application member connected to the frame or to the coulter and disposed to apply fluid to a rhizosphere of the plants.
12. The application unit of claim 11, wherein the at least one application member comprises a first application member and a second application member.
13. The application unit of claim 1 further comprising a fluid application line connected to the frame and disposed behind the opening disc in a direction of travel to apply fluid to the trench.
14. The application unit of claim 11, wherein the opening disc has a frame, and further comprising an extending frame connected to the frame of the opening disc and disposed to extend behind the opening disc in a direction of travel, and a knife downwardly disposed from the extending frame and disposed to contact ground.
15. A fluid applicator, comprising:
 - a base disposed between plants in adjacent rows;
 - at least one application member connected to the base and disposed to apply fluid to a rhizosphere of the plants; and
 - a nozzle disposed at an end of the application member to dispense fluid from the application member to the rhizosphere of the plants.

16. The fluid applicator of claim 15, wherein the at least one application member comprises a first application member with a first nozzle and a second application member with a second nozzle.
17. The fluid applicator of claim 15, wherein the nozzle further comprises a wire extending from the nozzle and disposed to contact the plant.
18. The fluid applicator of claim 15, wherein the nozzle further comprises a ski disposed under the nozzle.
19. The fluid applicator of claim 15, wherein the nozzle further comprises an aerator.
20. The fluid applicator or claim 19, wherein the aerator is disposed on a bottom of the nozzle.

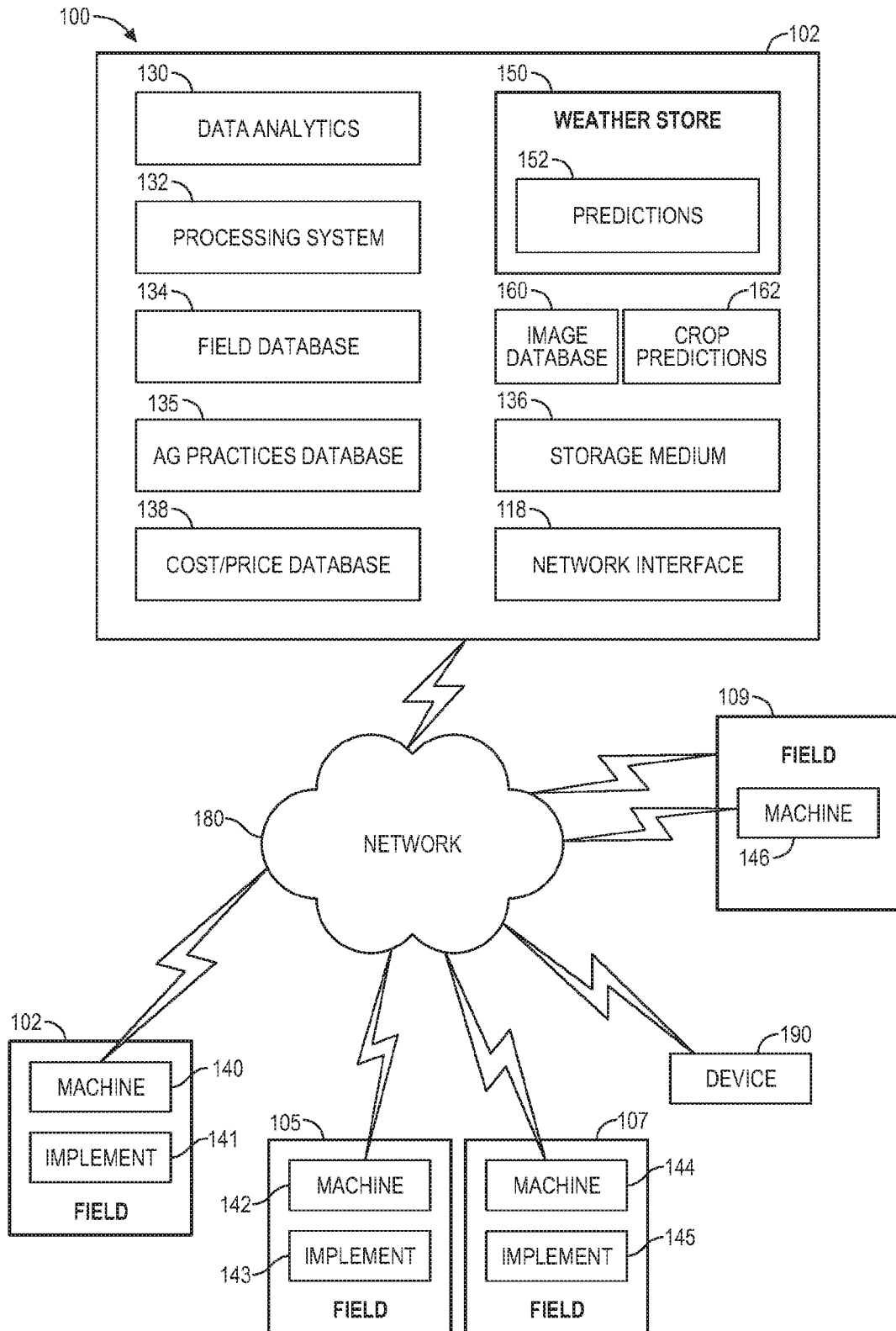

FIG. 1

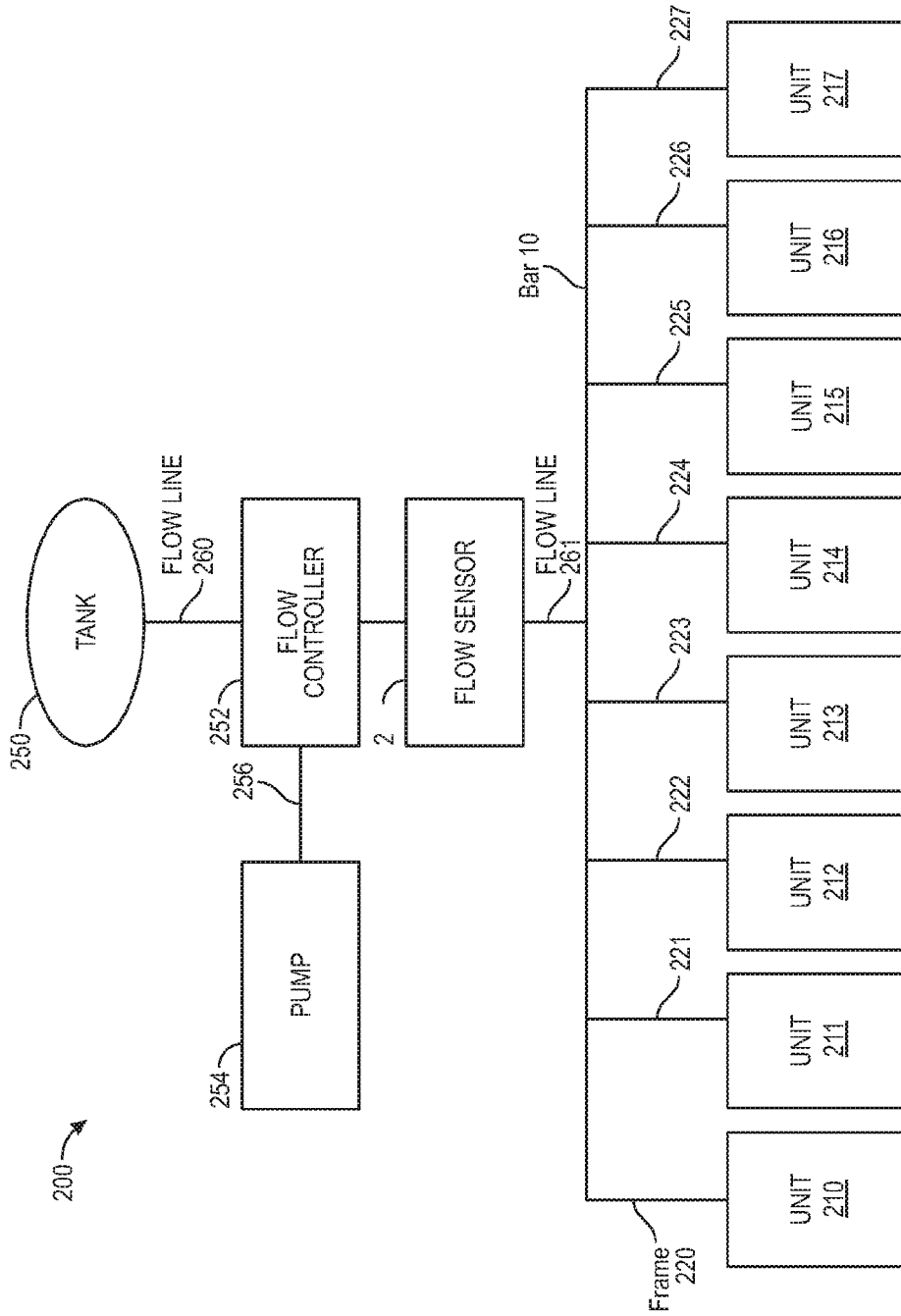

FIG. 2

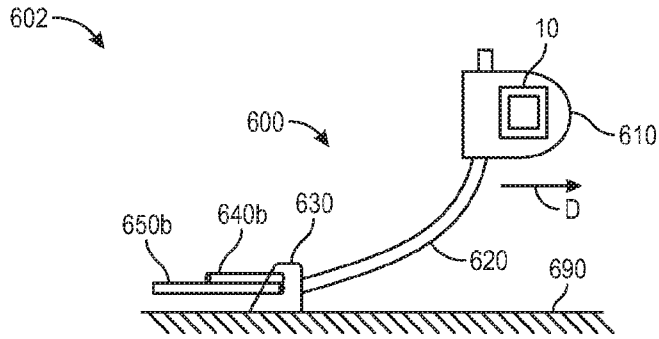

FIG. 6A

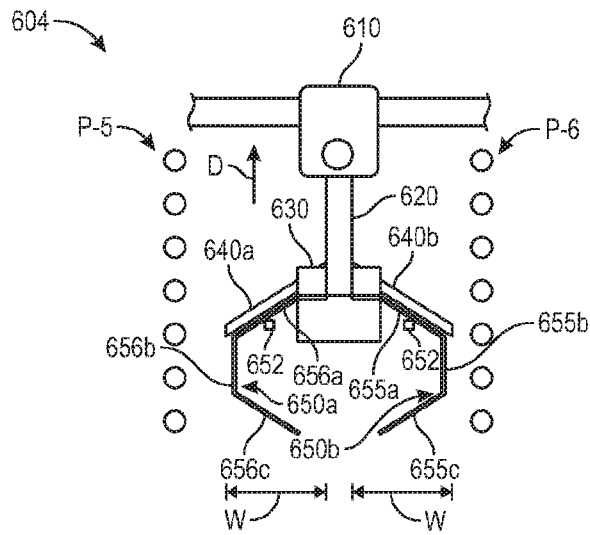

FIG. 6B

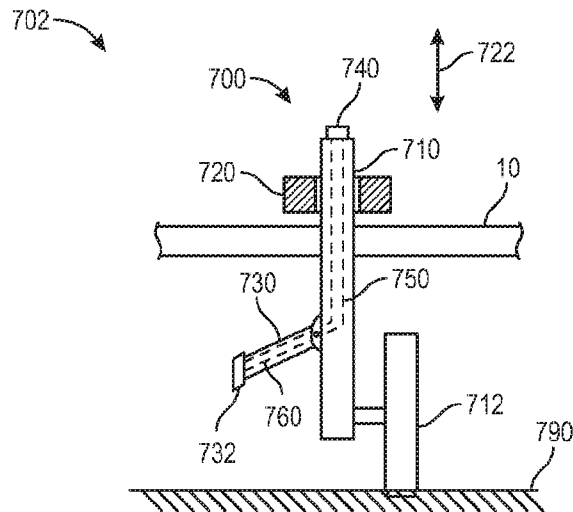

FIG. 7

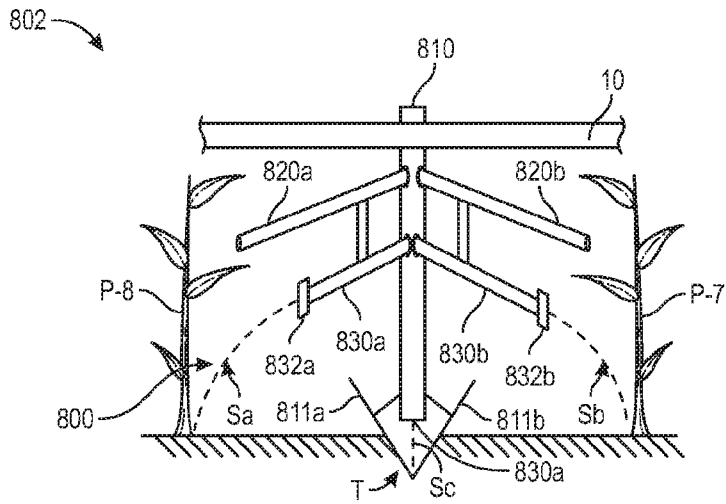

FIG. 8A

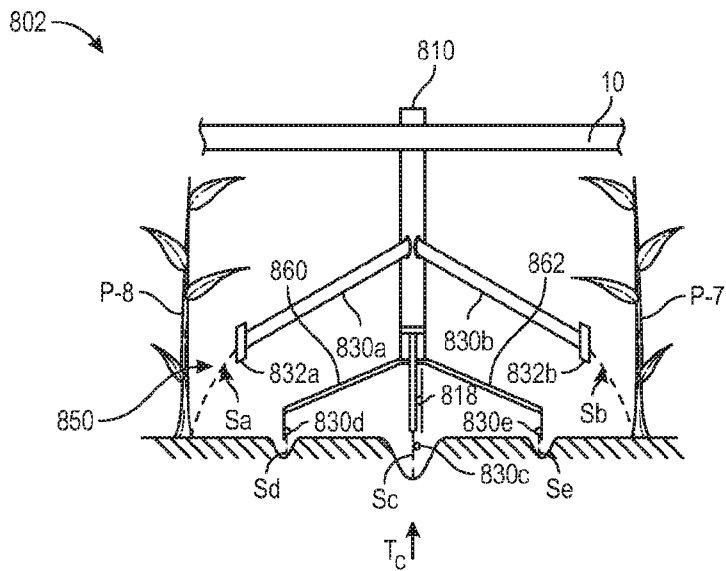

FIG. 8B

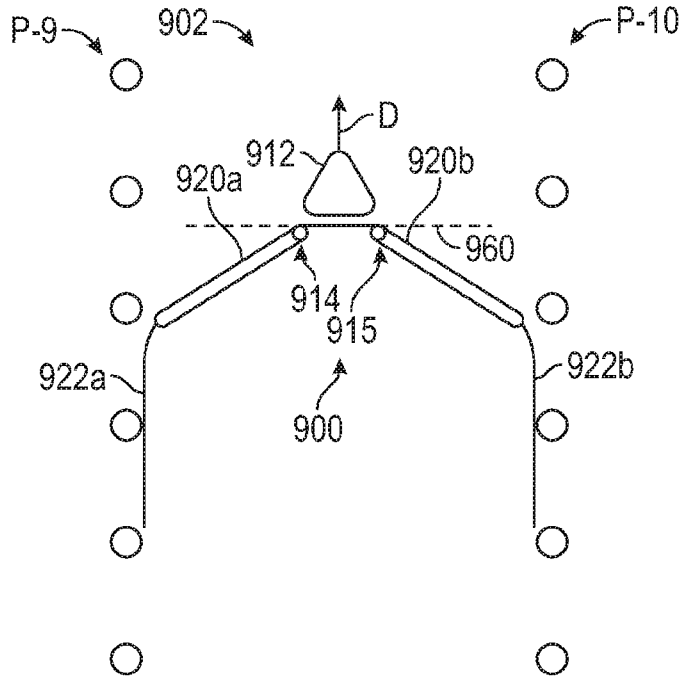

FIG. 9A

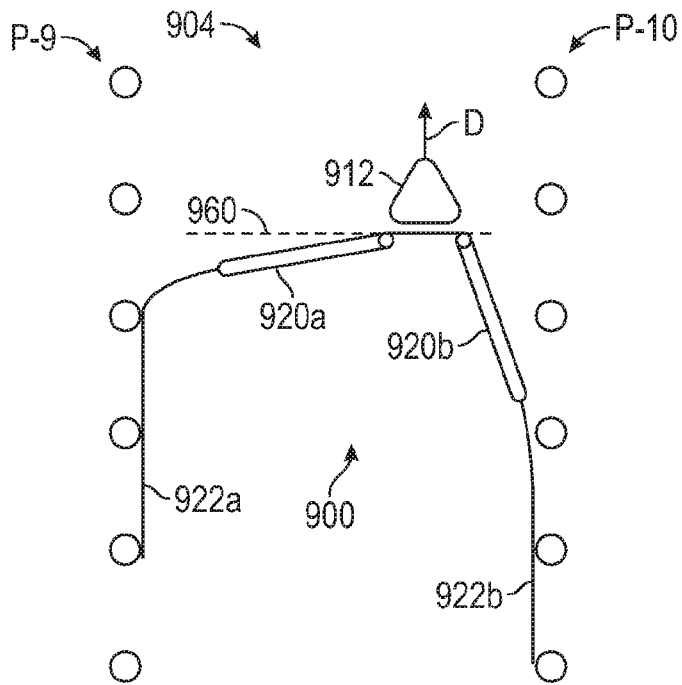
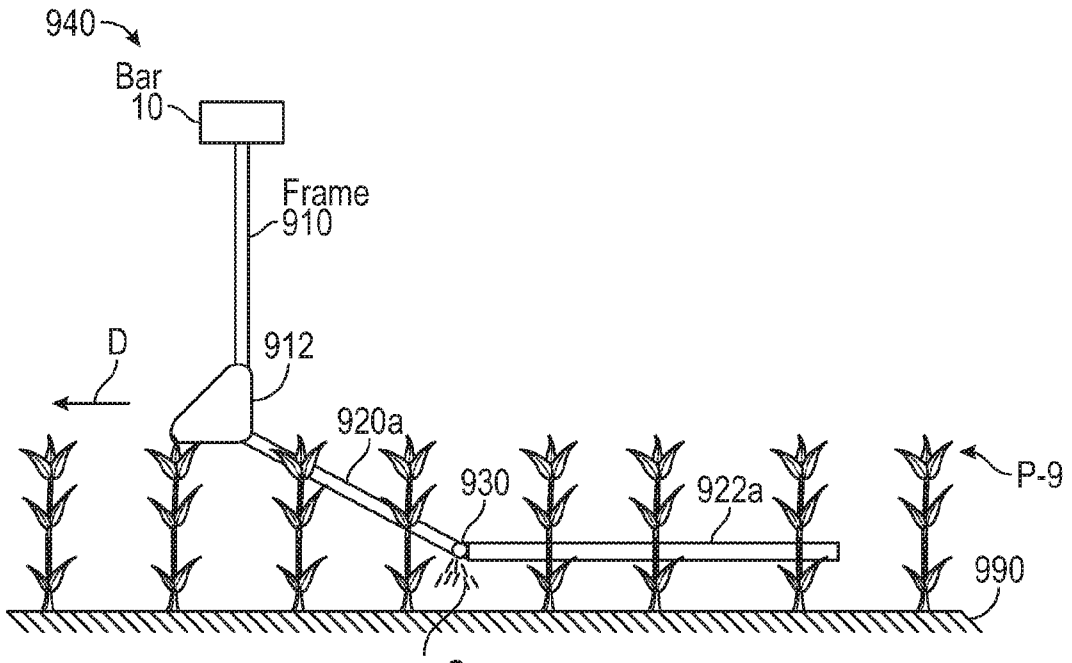

FIG. 9B



Sa
FIG. 9C

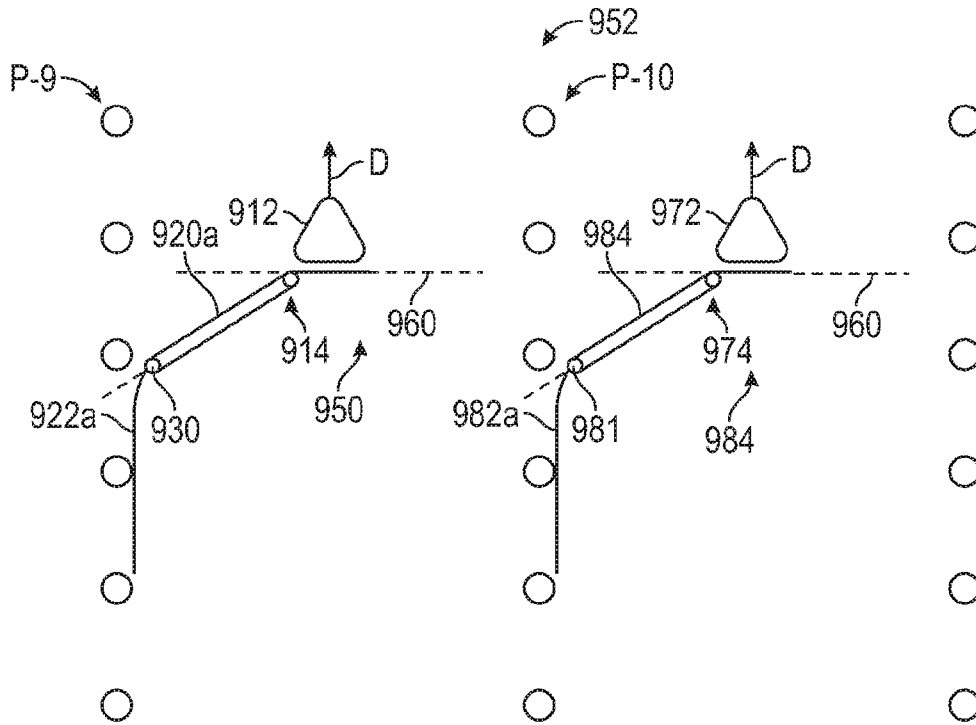

FIG. 9D

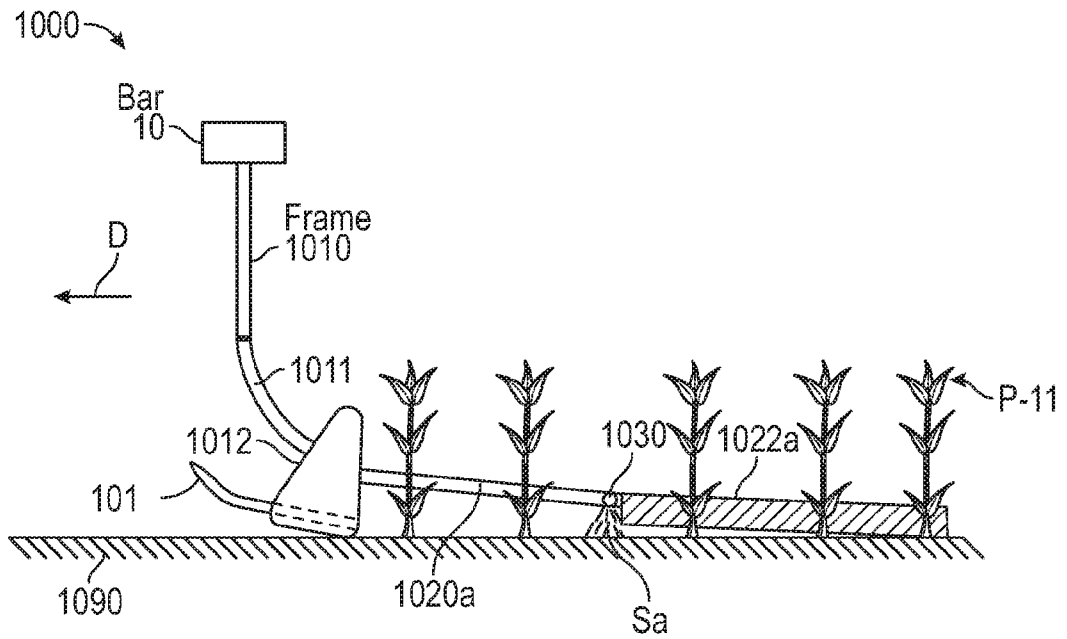

FIG. 10

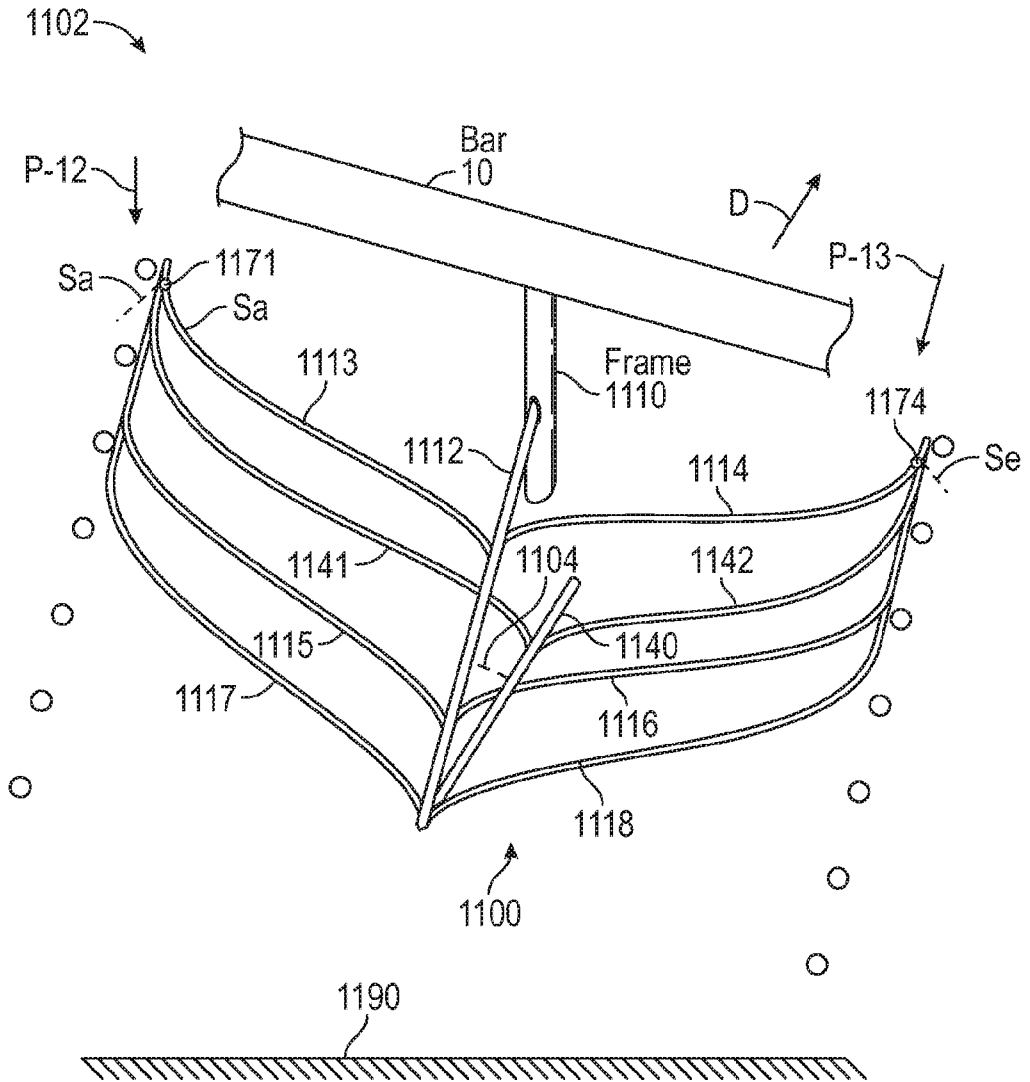

FIG. 11

10/36

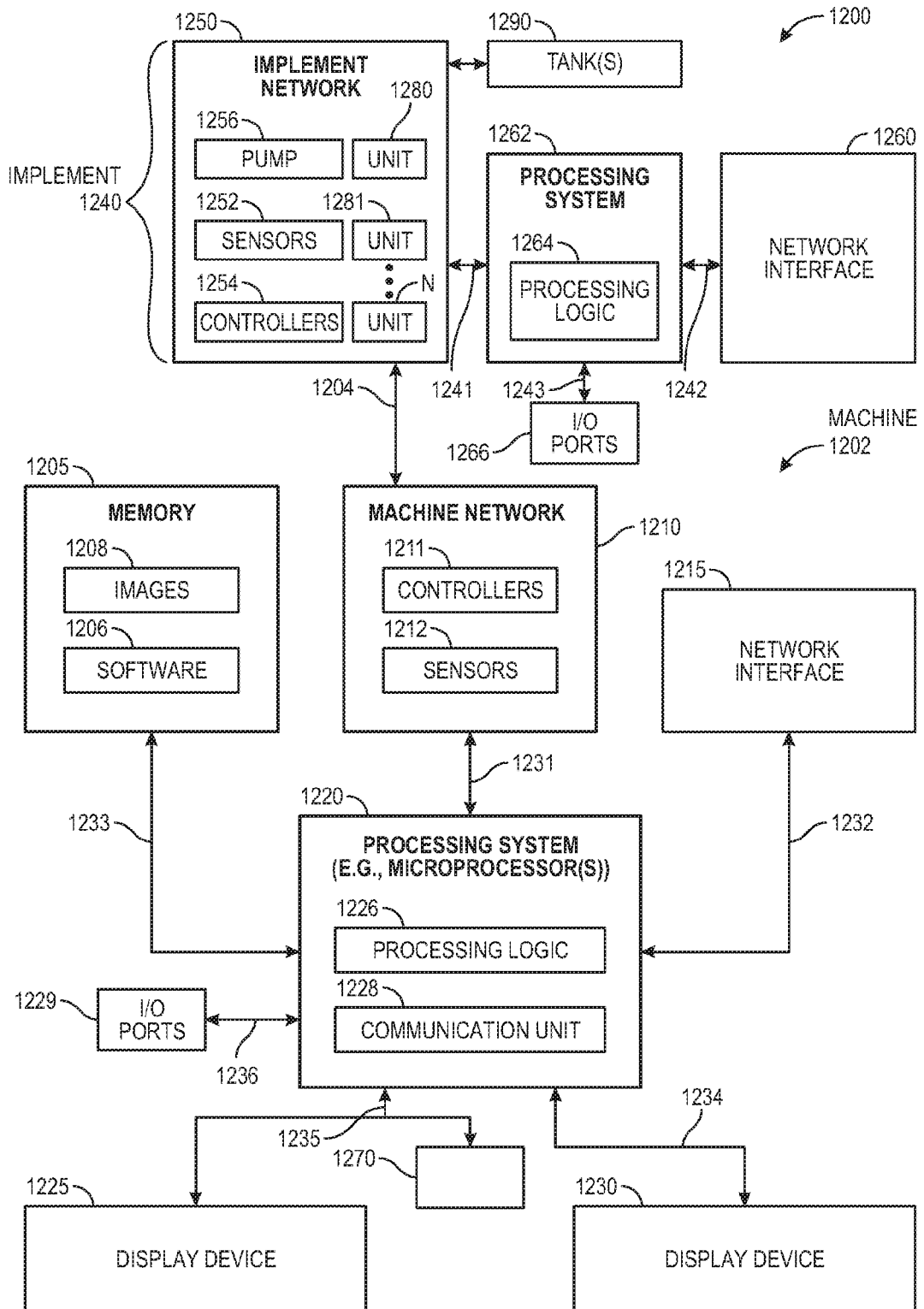

FIG. 12

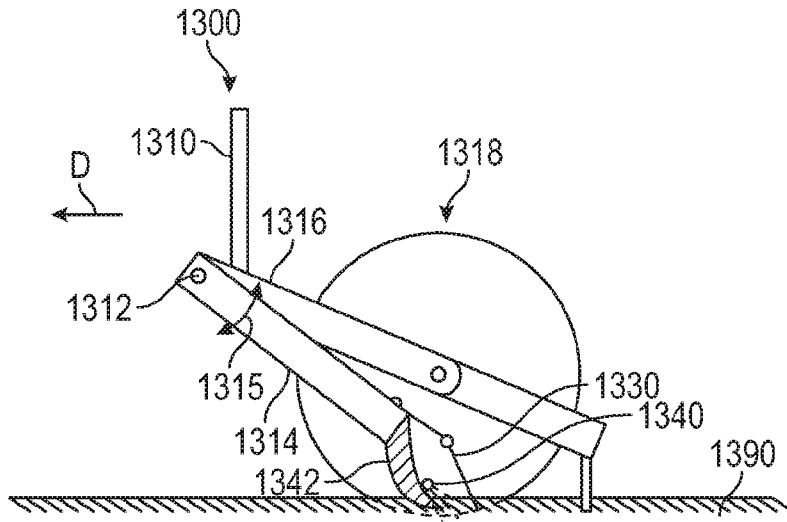

FIG. 13A

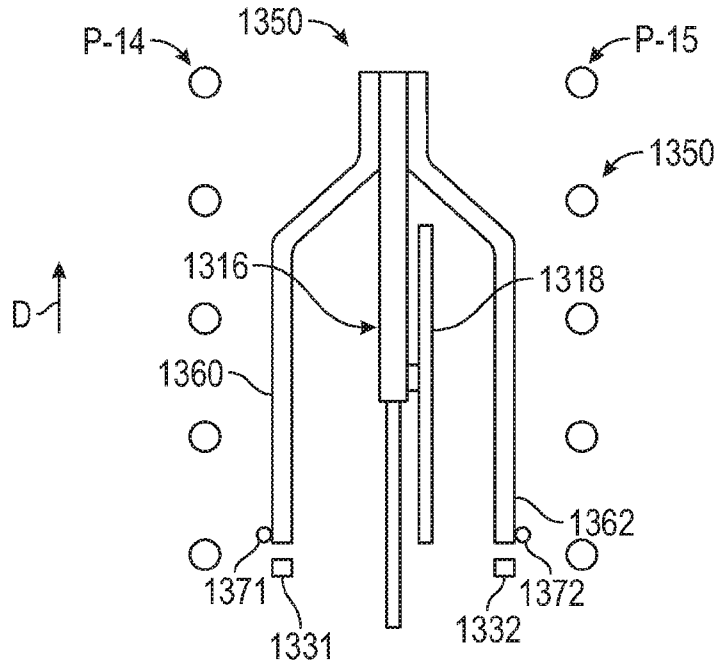

FIG. 13B

12/36

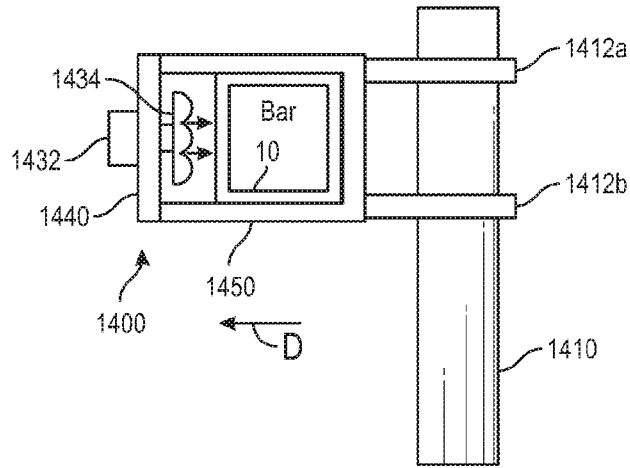

FIG. 14

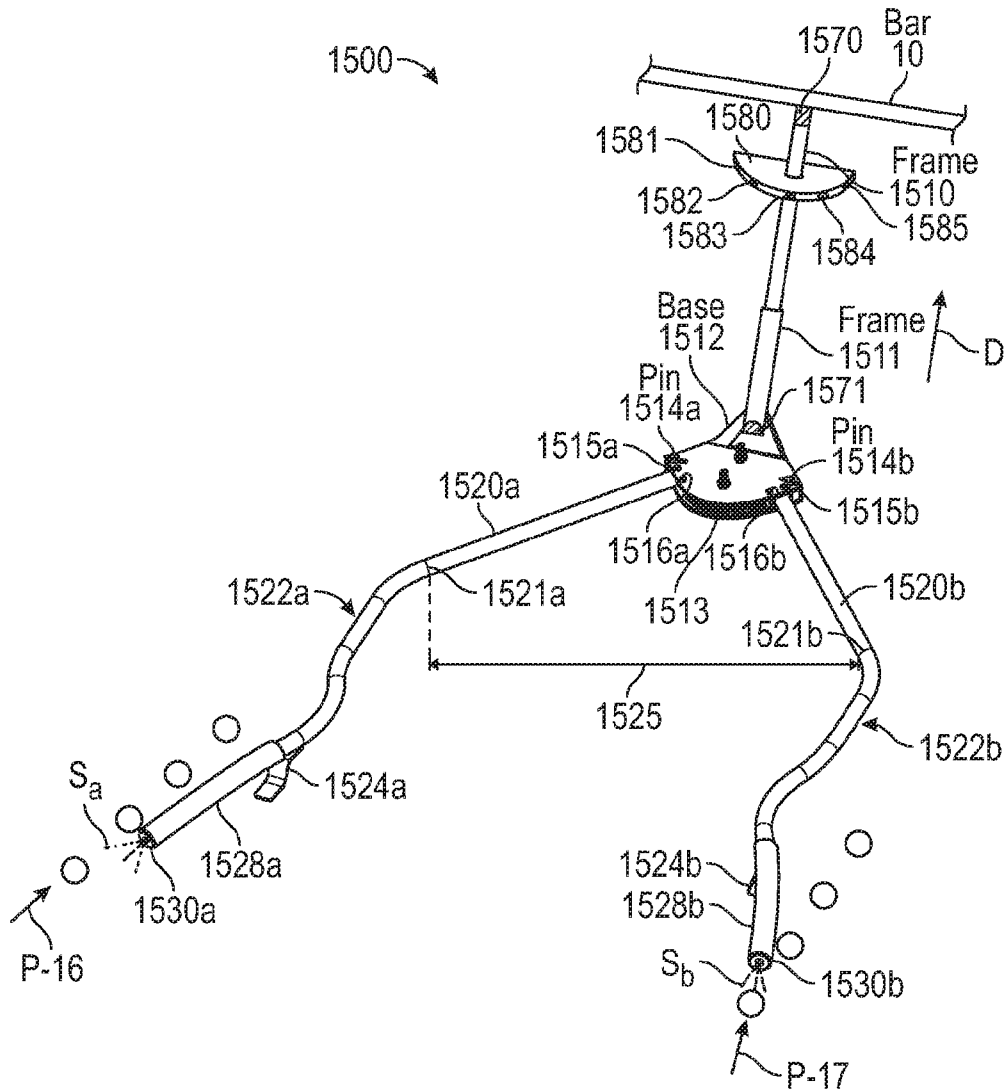

FIG. 15A

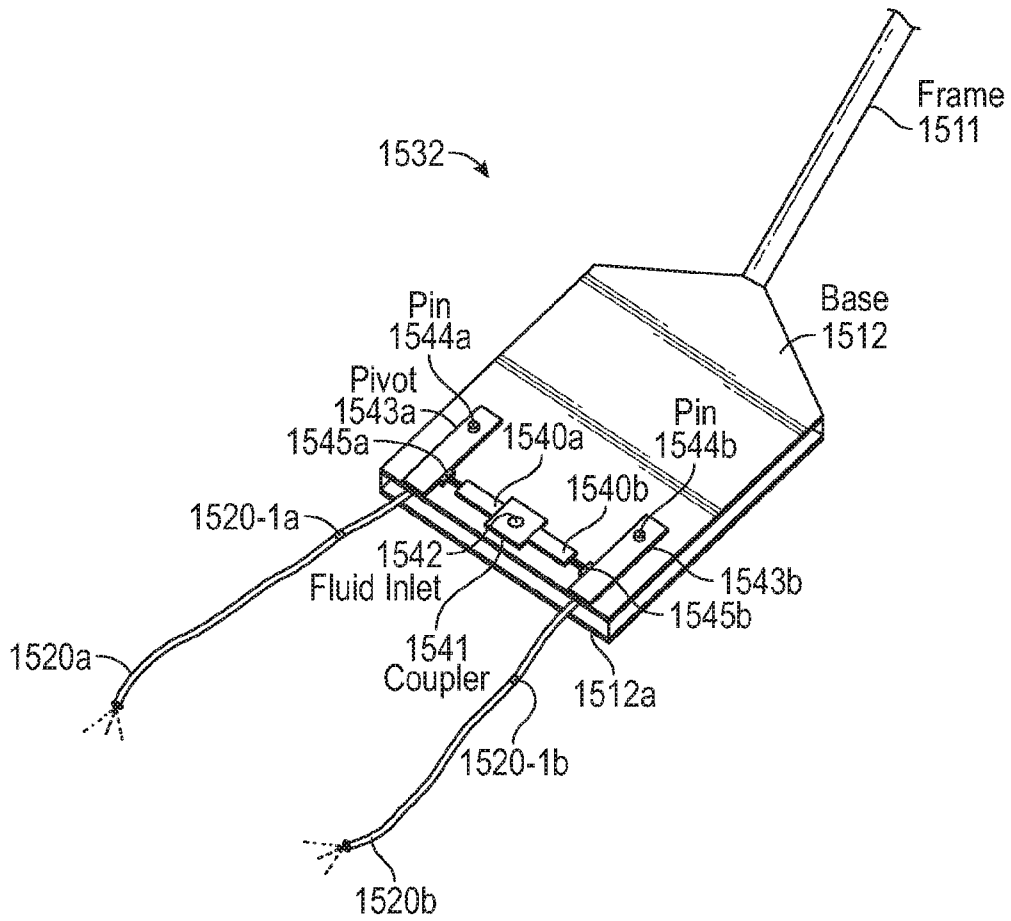

FIG. 15B

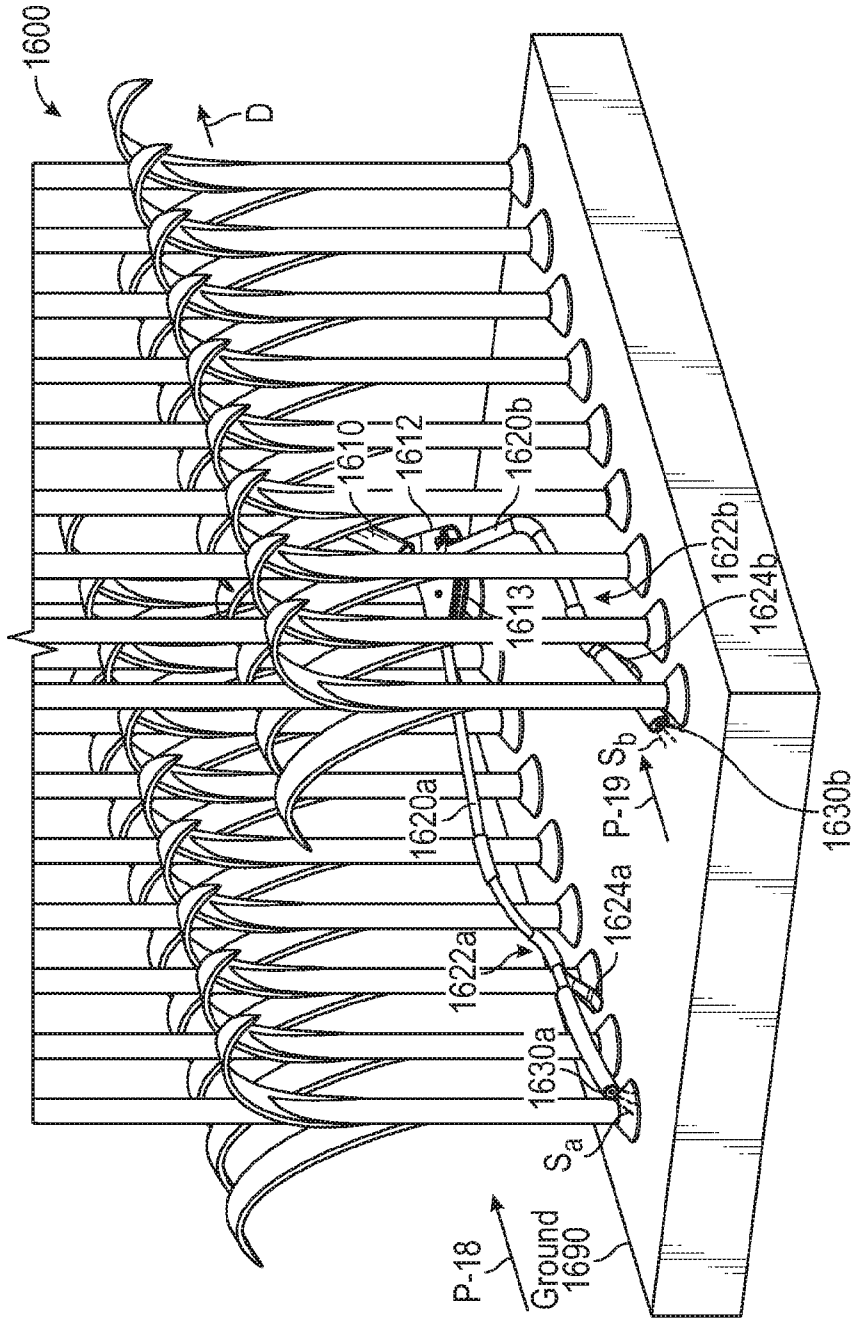

FIG. 16

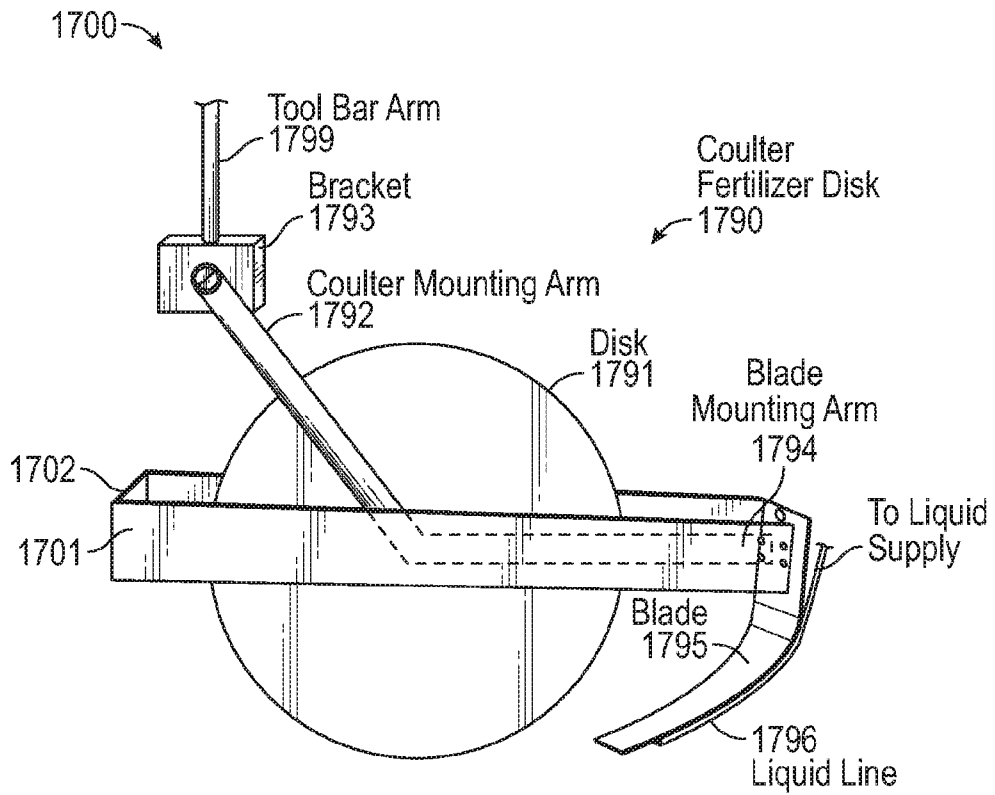

FIG. 17A

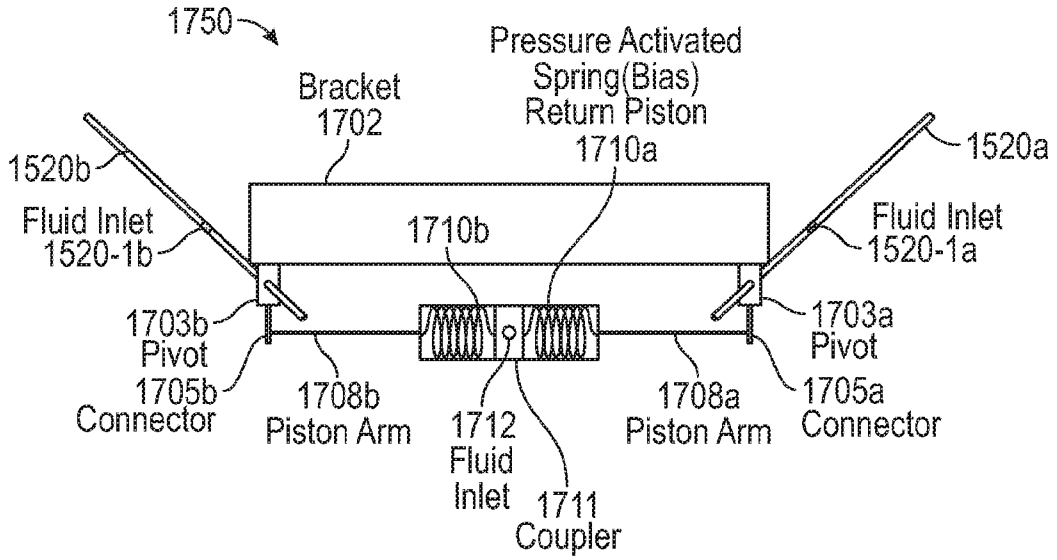

FIG. 17B

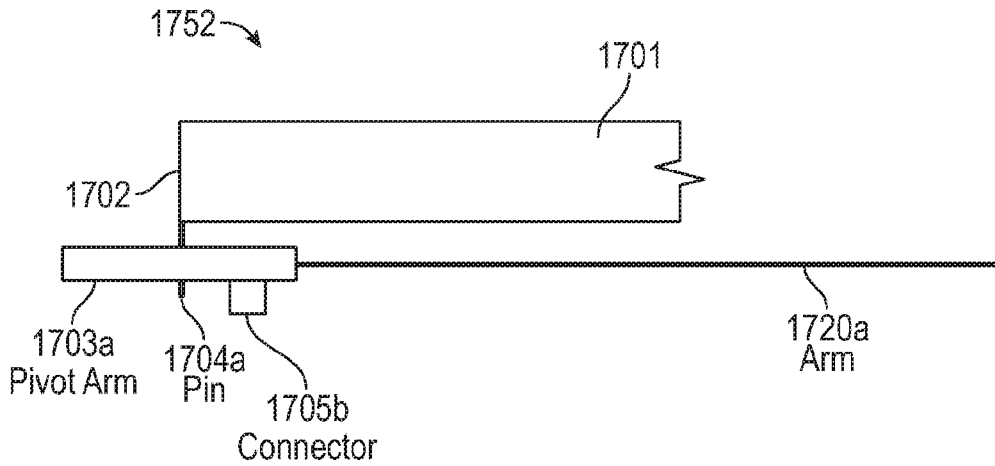

FIG. 17C

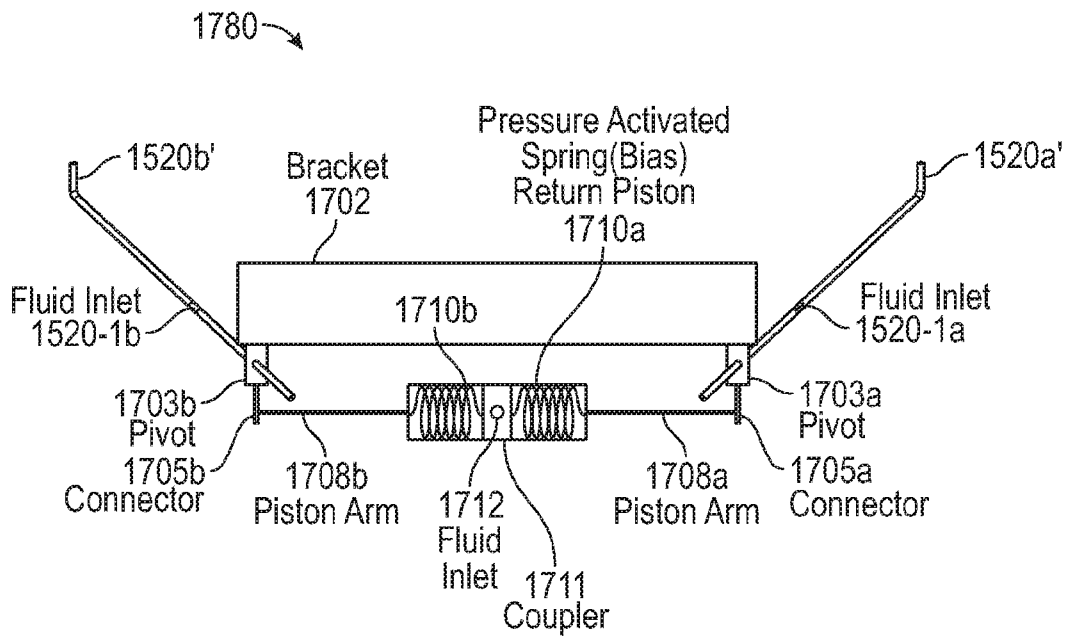

FIG. 17D

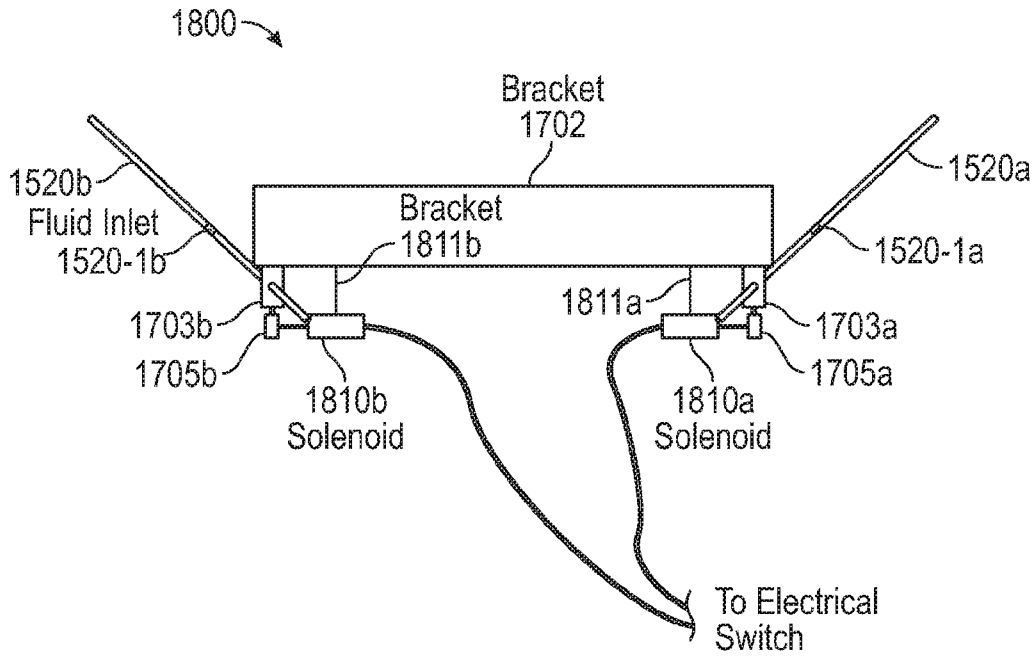

FIG. 18A

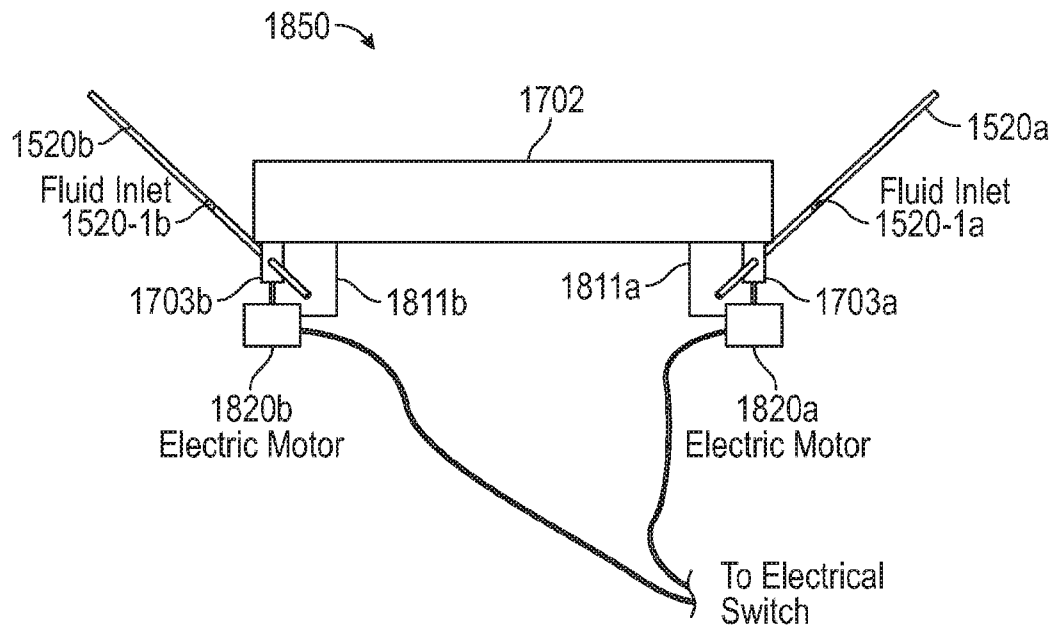

FIG. 18B

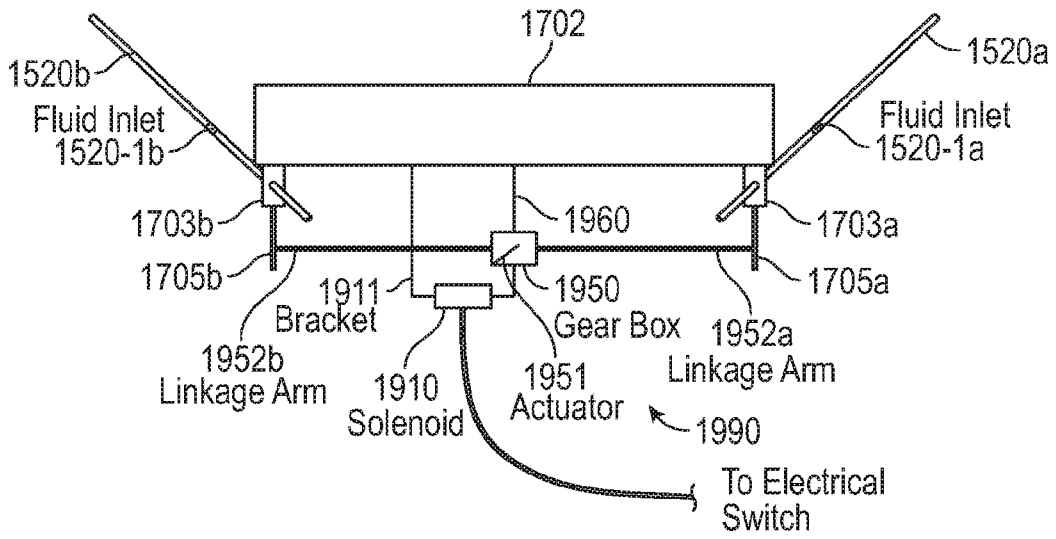

FIG. 19A

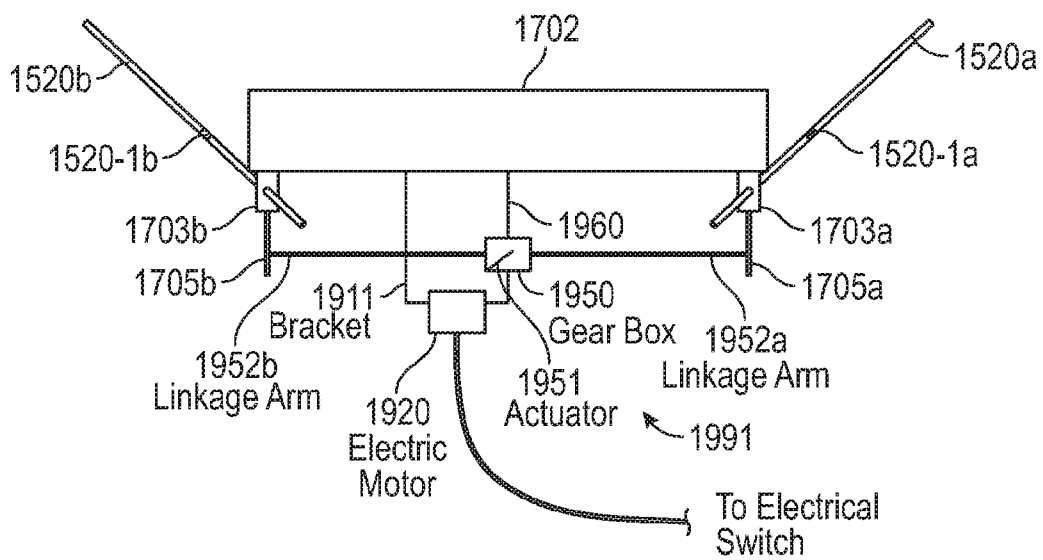

FIG. 19B

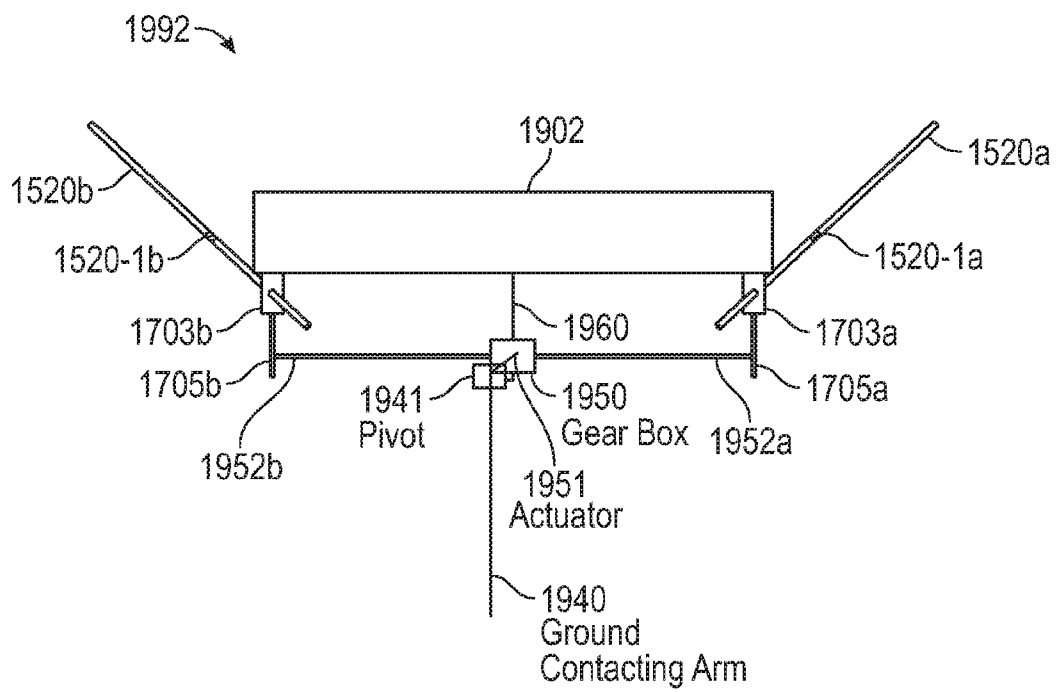

FIG. 19C

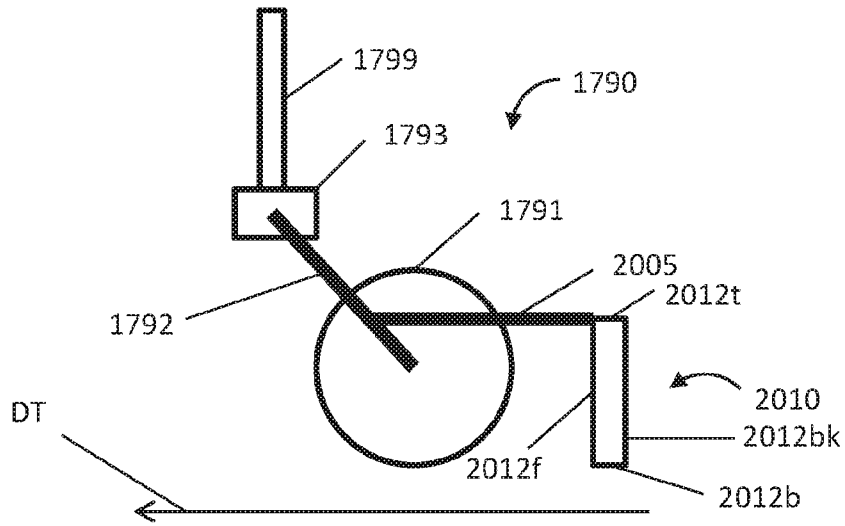

Figure 20A

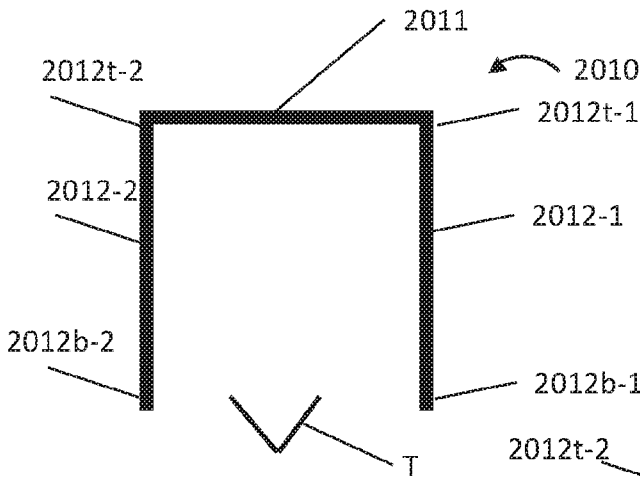

Figure 20B

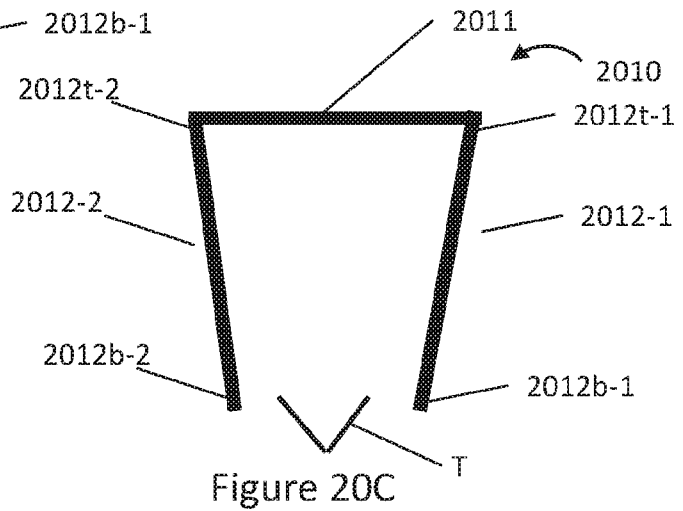

Figure 20C

22/36

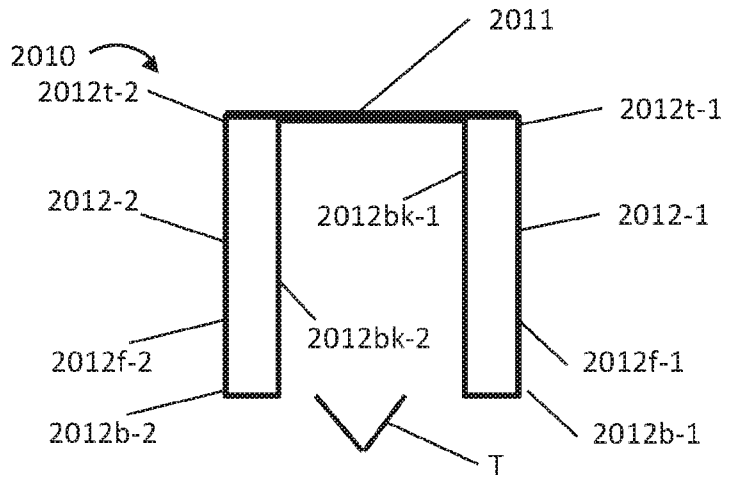

Figure 20D

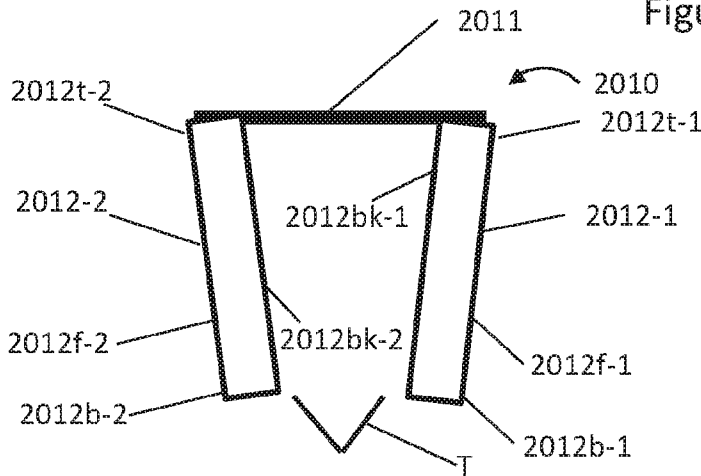

Figure 20E

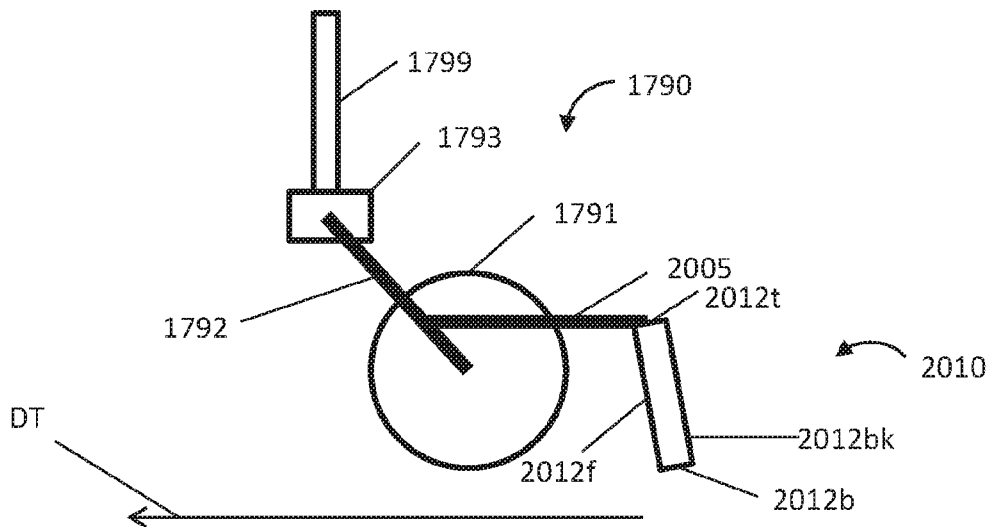

Figure 20F

23/36

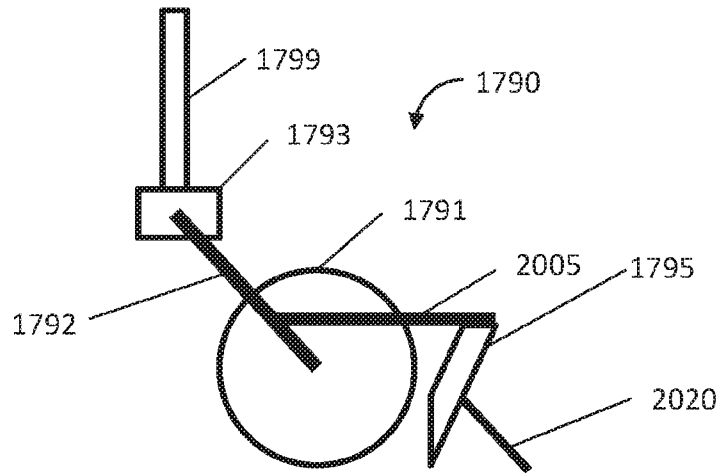

Figure 21A

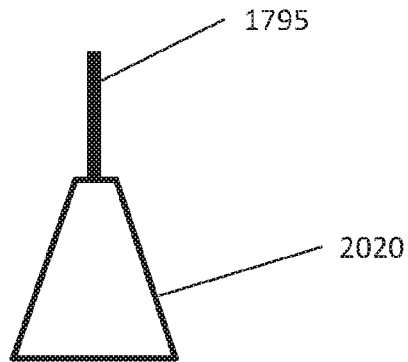

Figure 21B

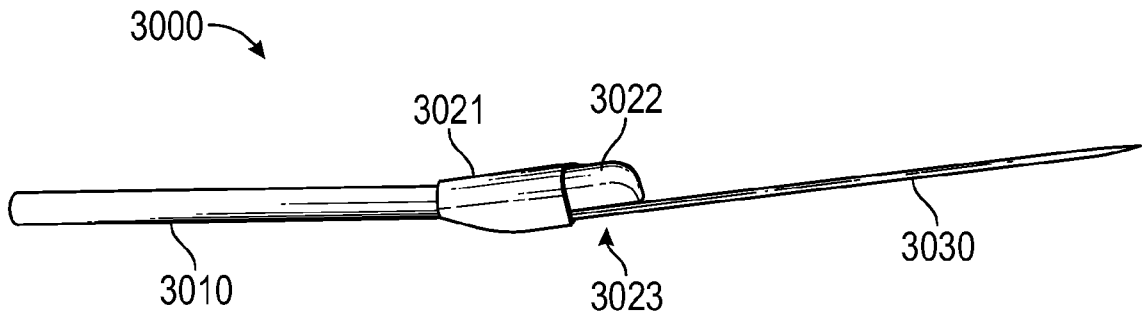

FIG. 22A

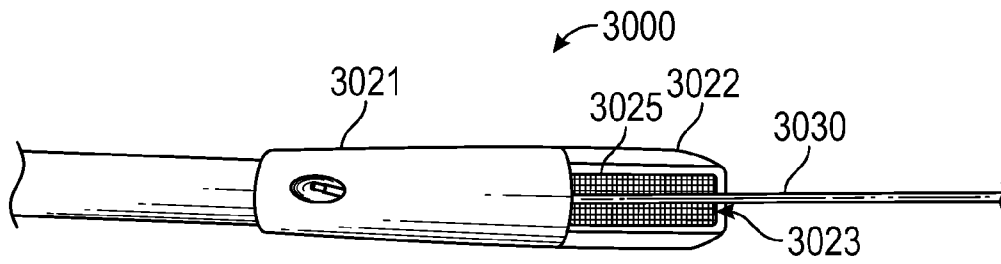

FIG. 22B

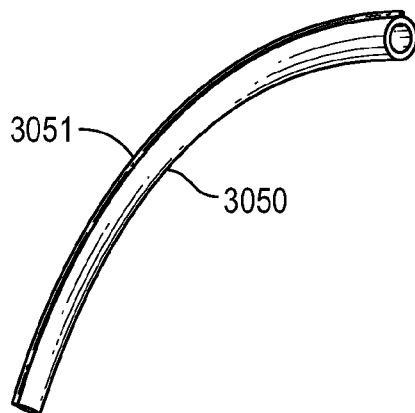

FIG. 23

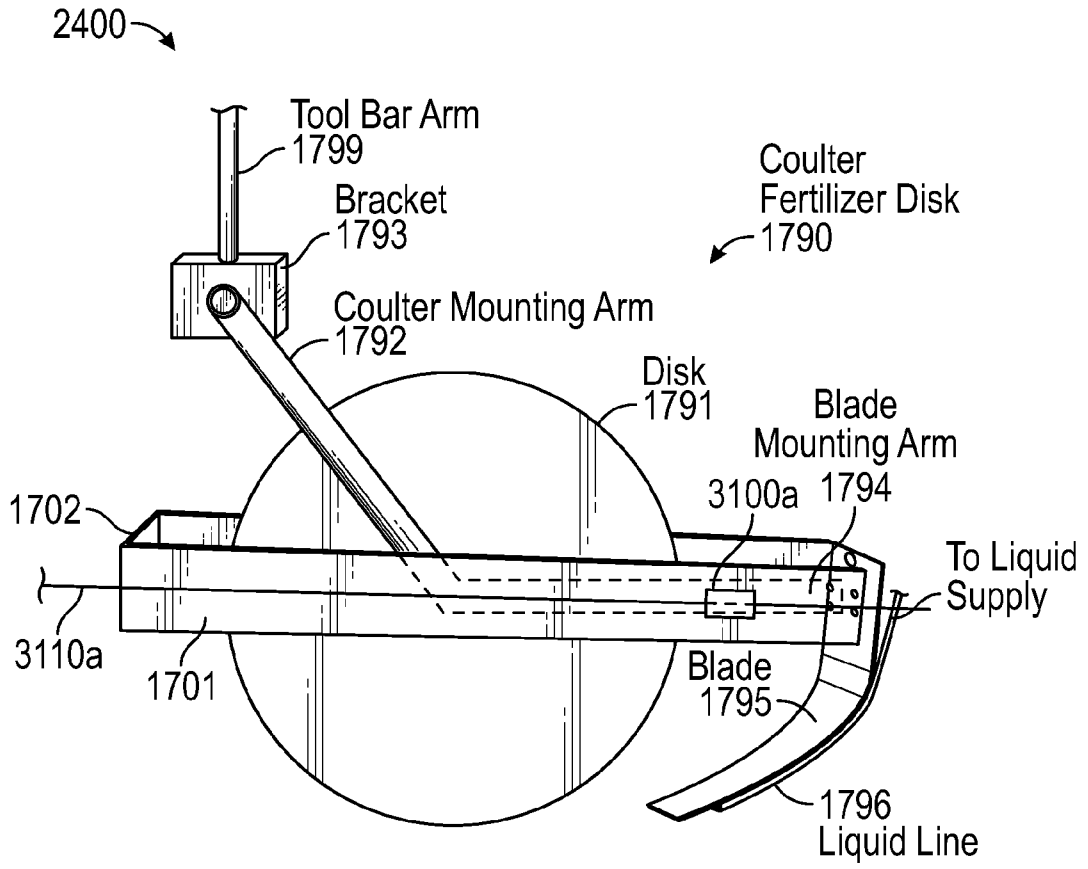

FIG. 24A

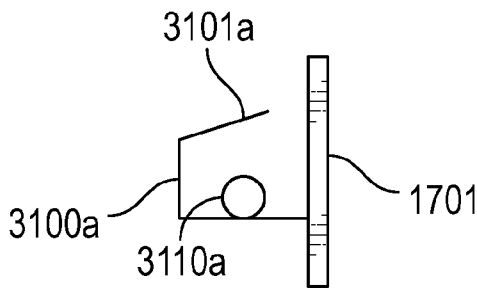

FIG. 24B

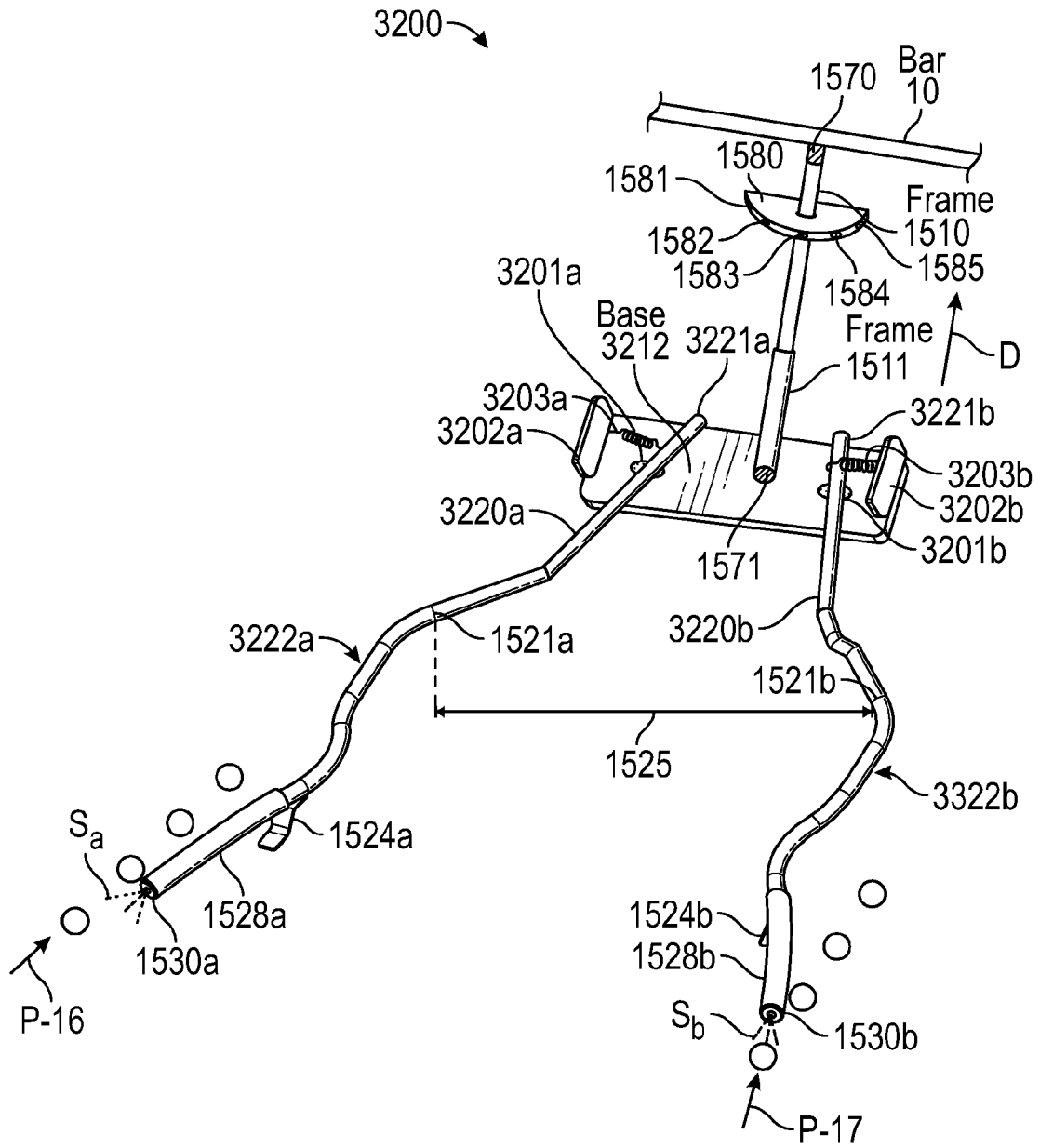

FIG. 25

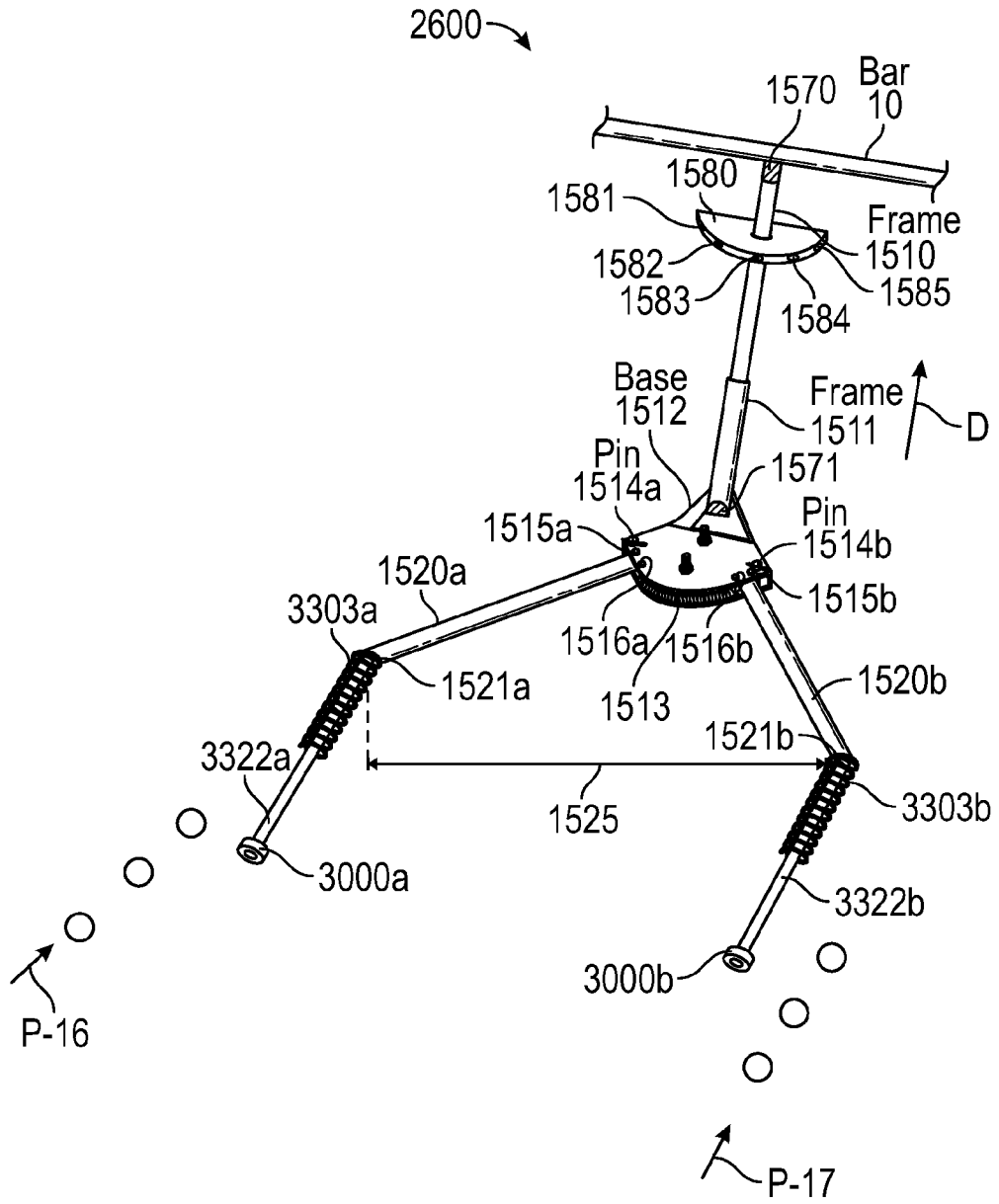

FIG. 26

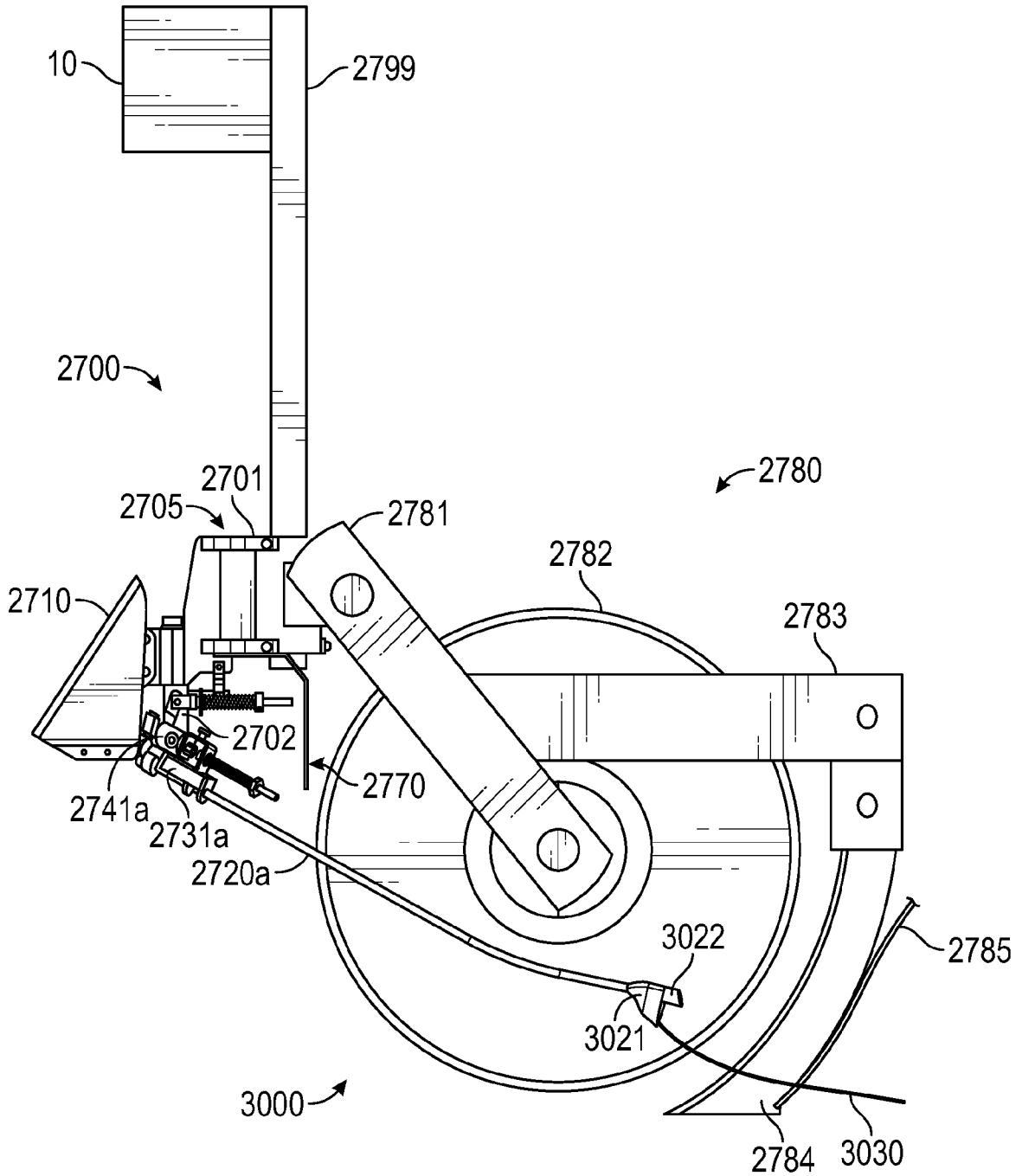

FIG. 27A

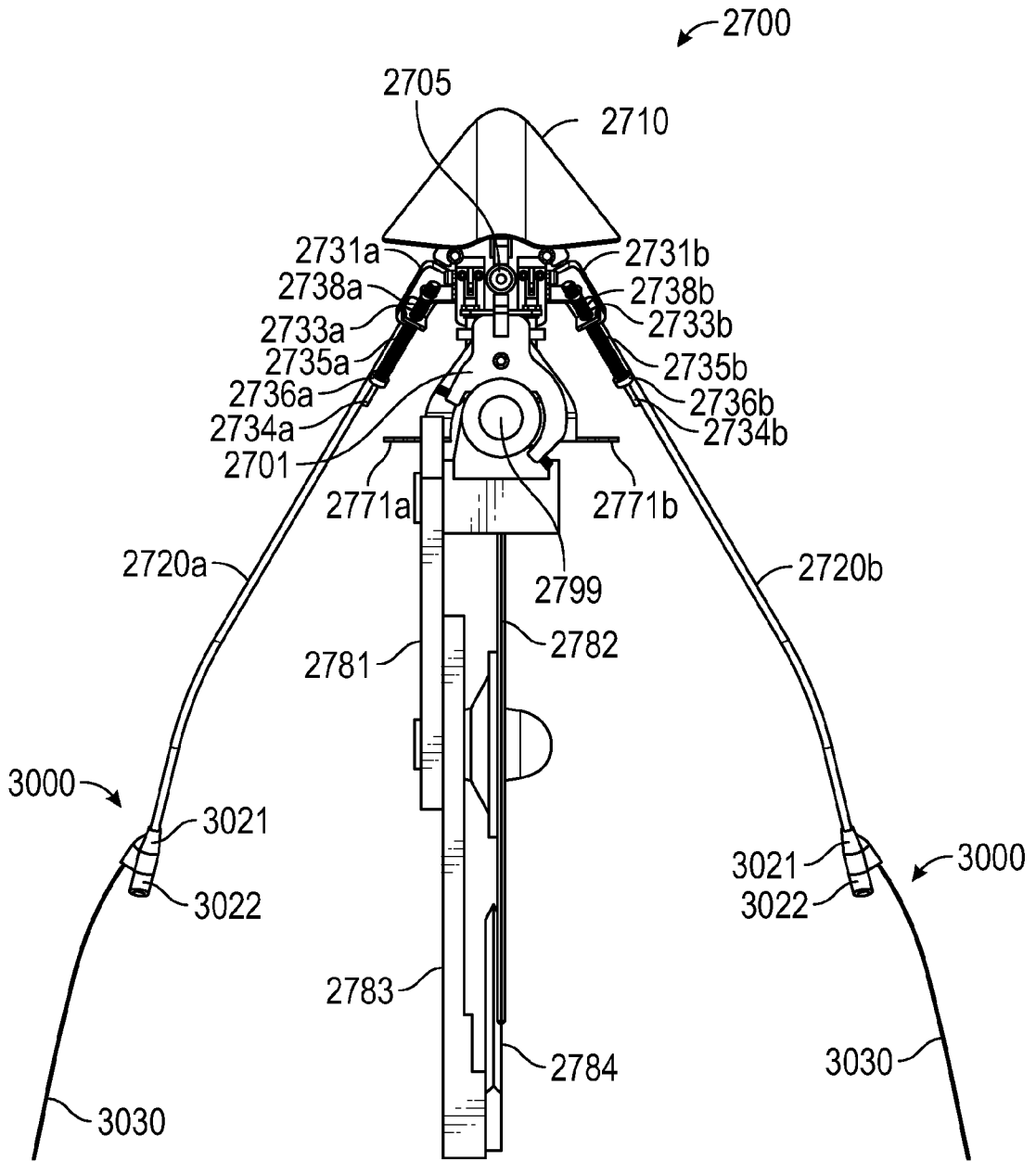

FIG. 27B

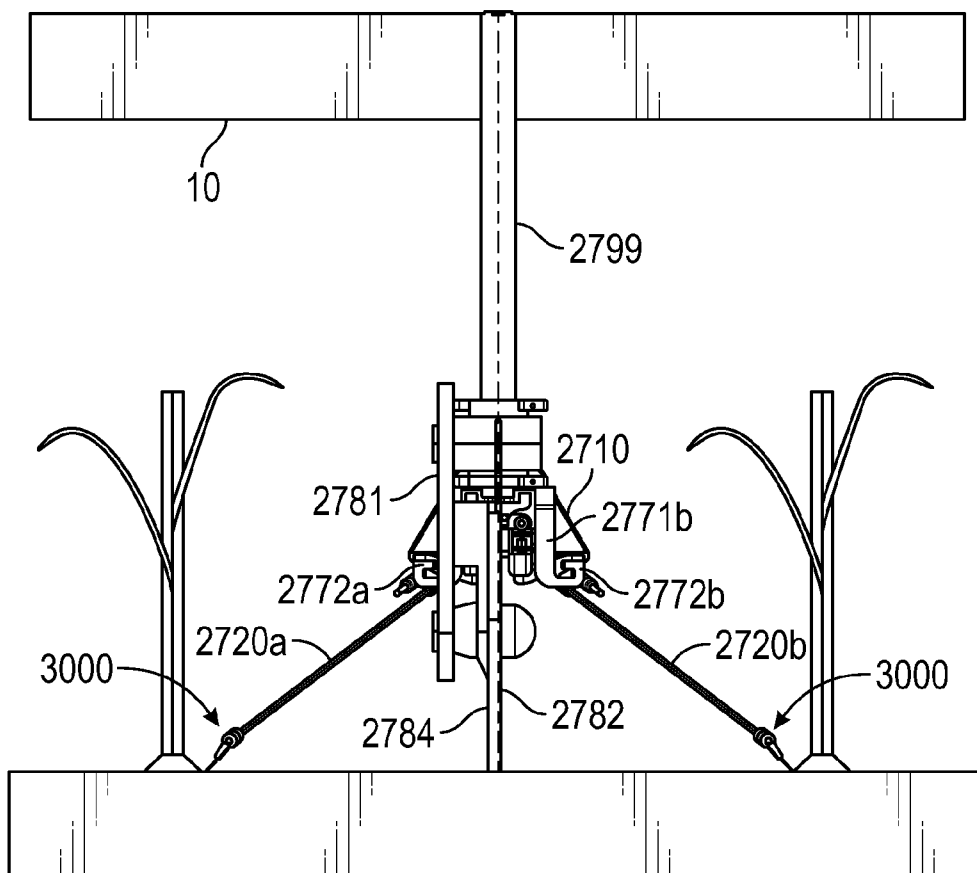

FIG. 27C

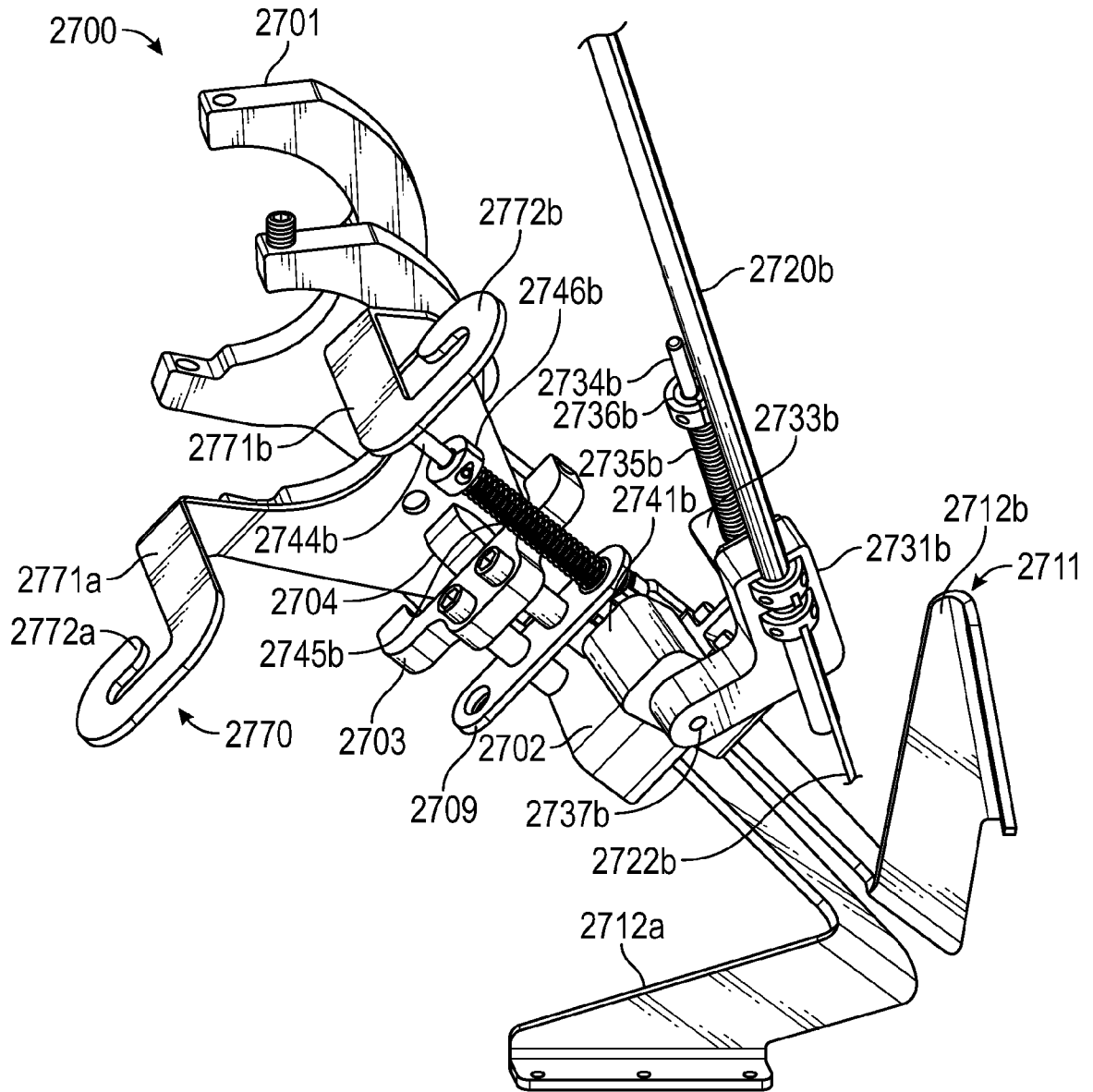

FIG. 27D

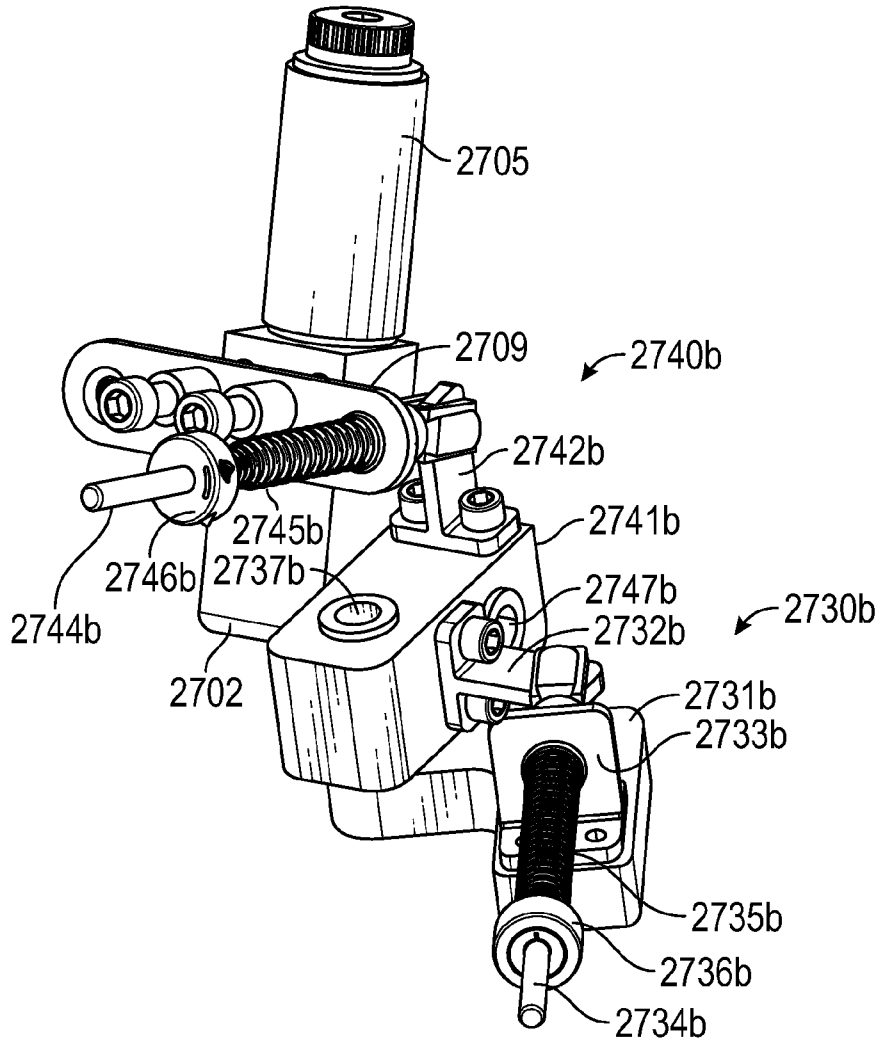

FIG. 27E

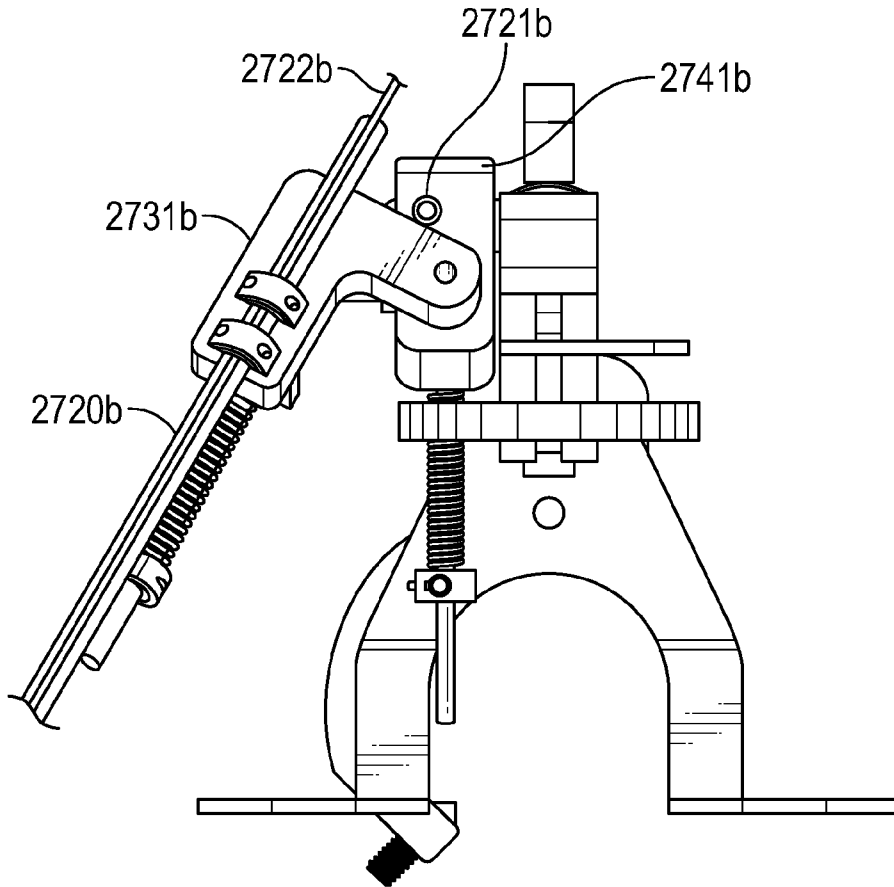

FIG. 27F

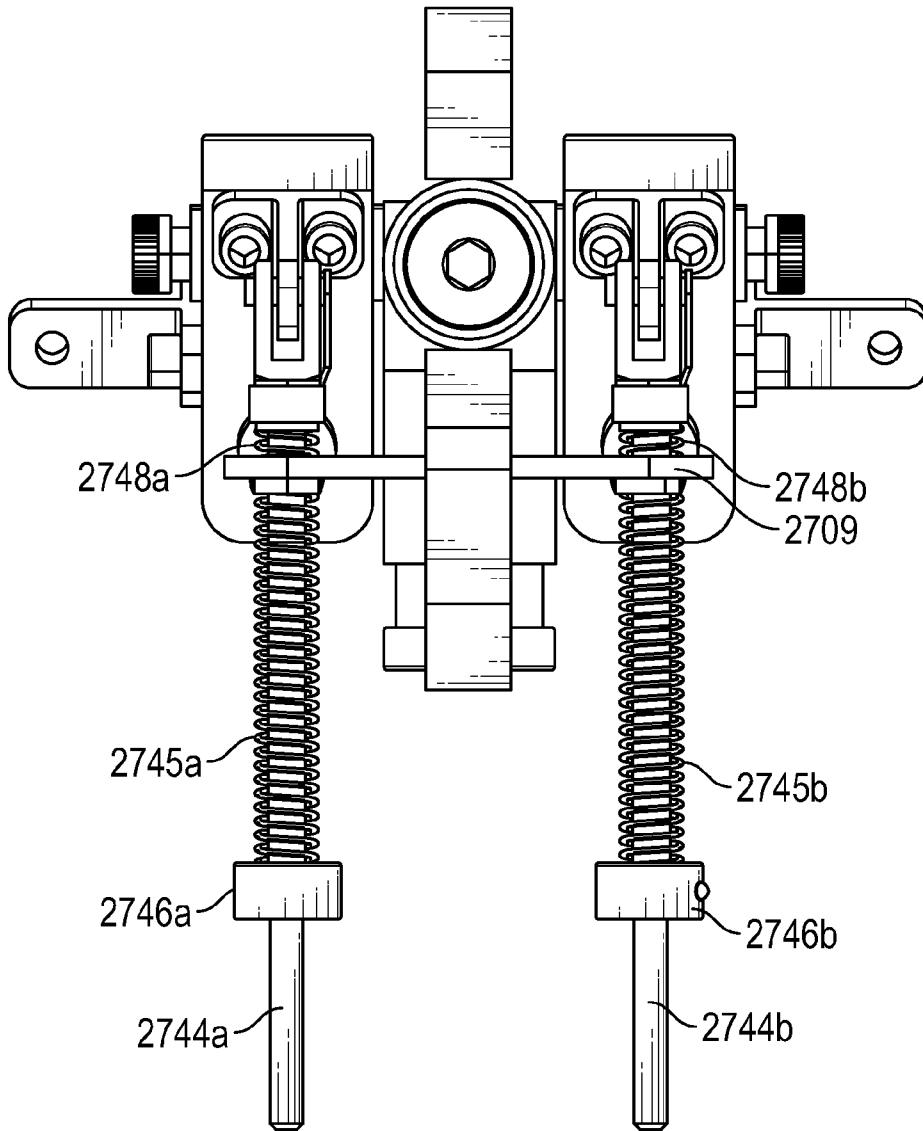
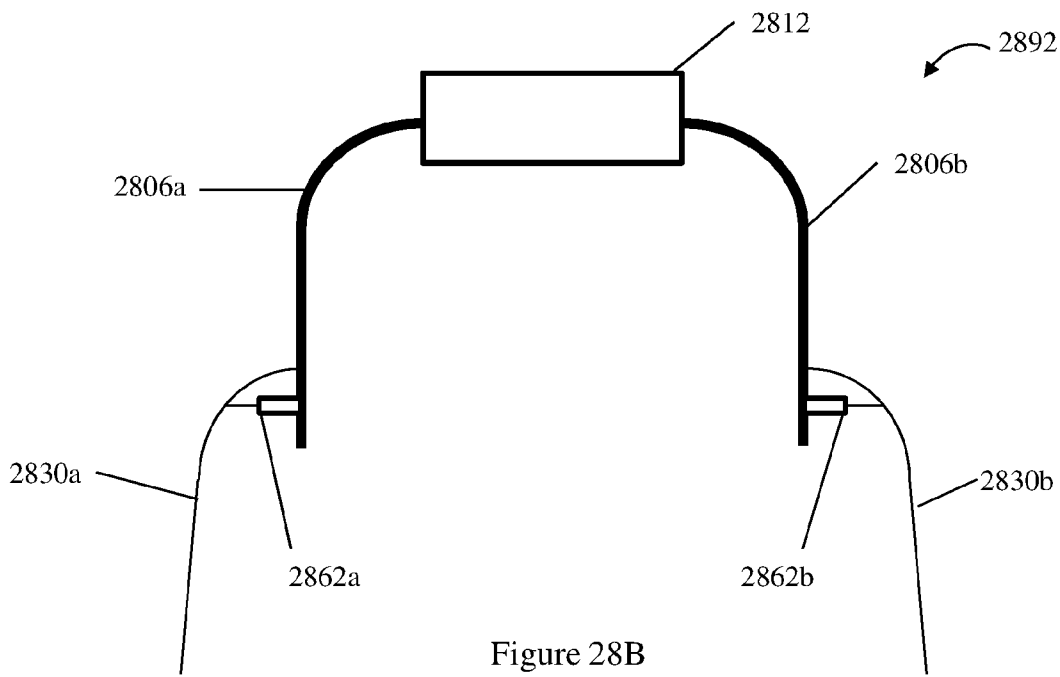
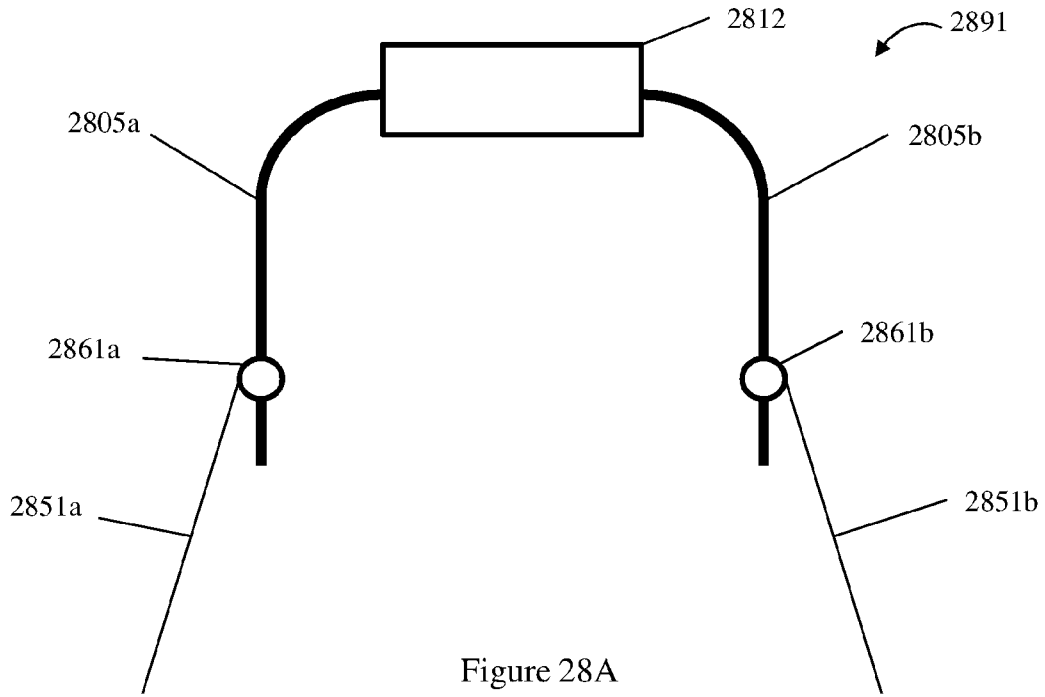

FIG. 27G



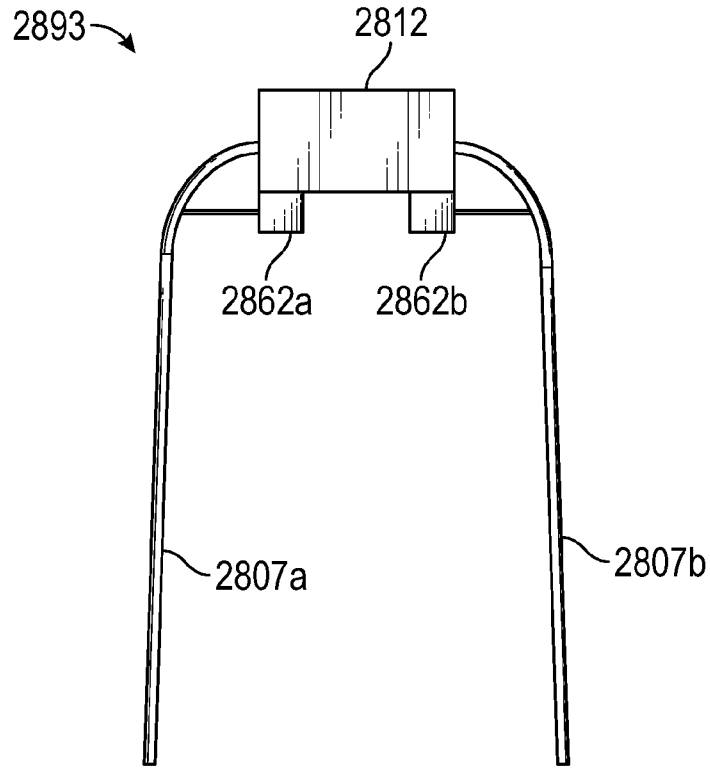

FIG. 28C

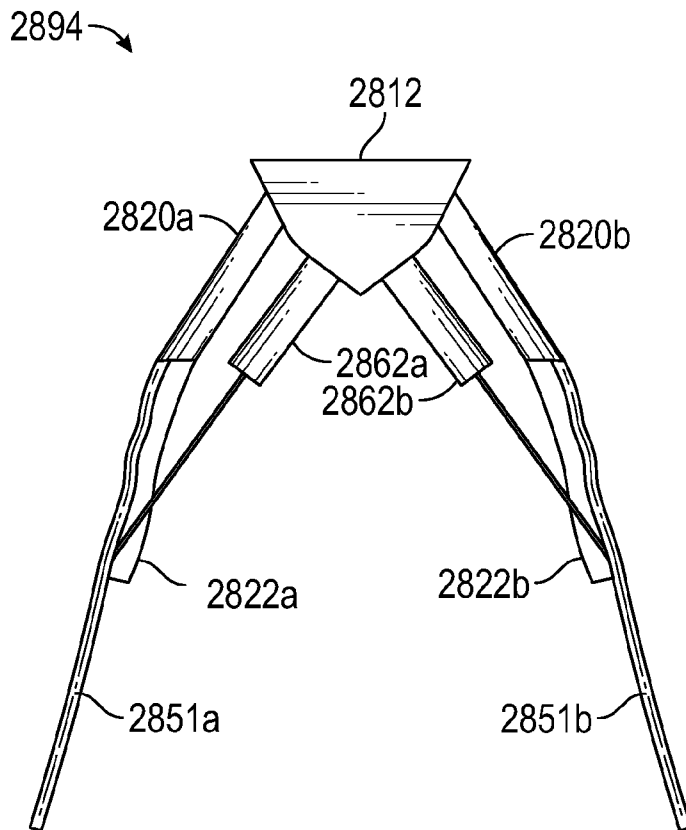

FIG. 28D

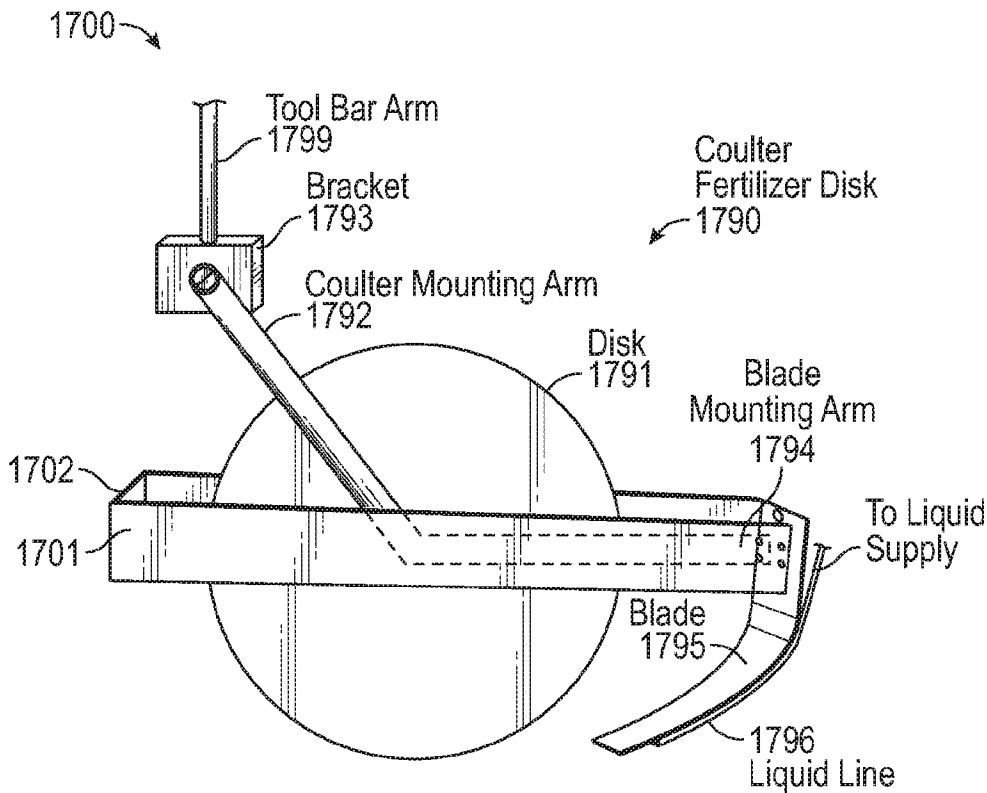

FIG. 17A