

W. KANE.
 GAS HEATER FOR STEAM BOILERS.
 APPLICATION FILED AUG. 20, 1908.

1,002,278.

Patented Sept. 5, 1911.

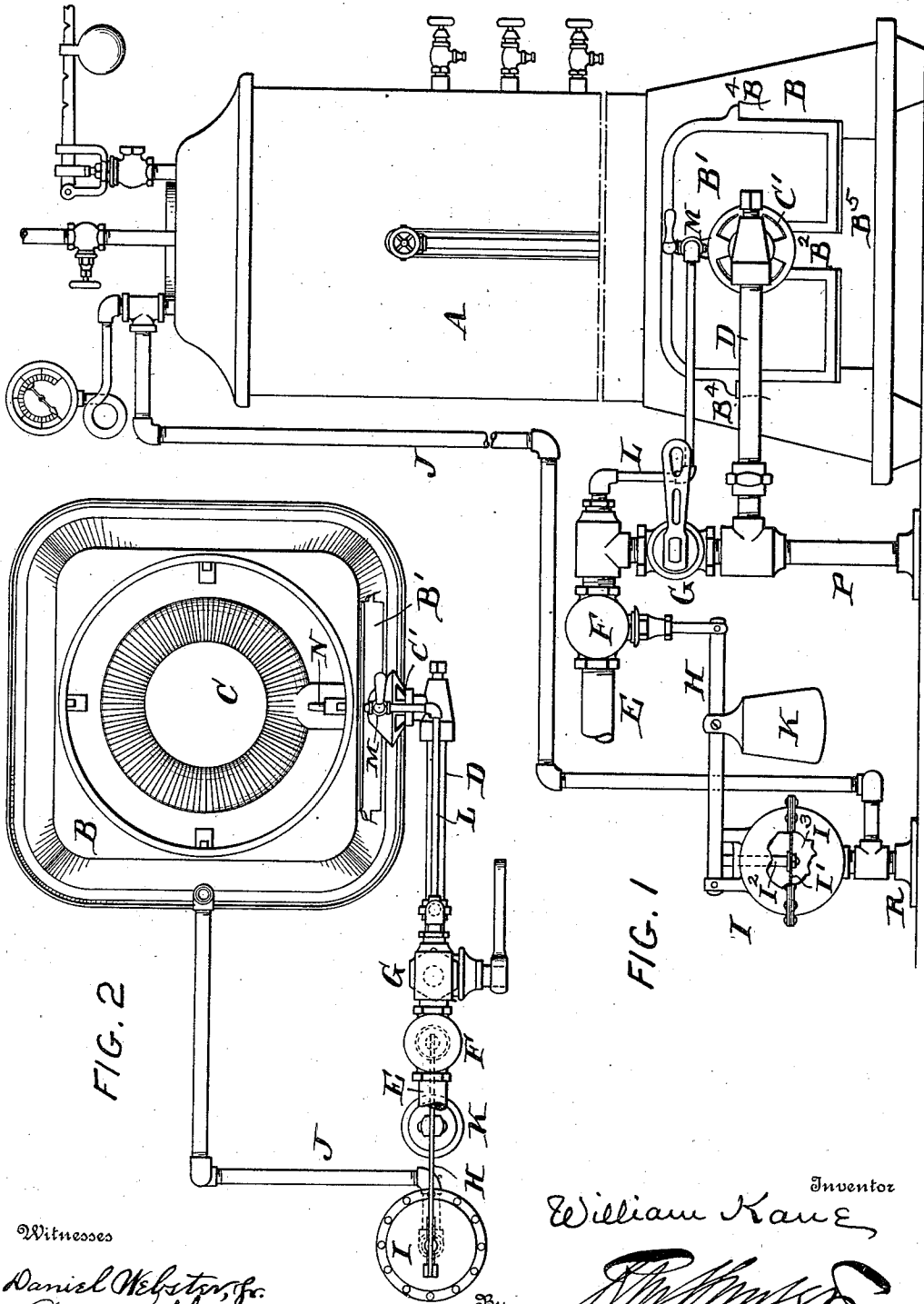

FIG. 2

FIG. 1

Witnesses
Daniel Webster, Jr.
A. M. Kelly.

Inventor
William Kane
 By *[Signature]*
 Attorney

UNITED STATES PATENT OFFICE.

WILLIAM KANE, OF PHILADELPHIA, PENNSYLVANIA.

GAS-HEATER FOR STEAM-BOILERS.

1,002,278.

Specification of Letters Patent.

Patented Sept. 5, 1911.

Application filed August 20, 1908. Serial No. 449,399.

To all whom it may concern:

Be it known that I, WILLIAM KANE, a citizen of the United States, and a resident of the city and county of Philadelphia and State of Pennsylvania, have invented an Improvement in Gas-Heaters for Steam-Boilers, of which the following is a specification.

My invention has reference to gas heaters for steam boilers and consists of certain improvements which are fully set forth in the following specification and shown in the accompanying drawings.

The object of my invention is to provide means for burning gas as fuel for heating a steam boiler and causing the temperature to be automatically controlled by regulating the gas supplied to the burner under the control of the steam pressure within the boiler.

My invention consists in providing a steam boiler with a gas burner, combined with a valve to control the supply of gas to the burner, and a steam actuated regulator for controlling the valve to regulate the heat supplied to the boiler and maintain the boiler pressure substantially constant.

My invention further consists in the above construction when the steam actuated regulator comprises a lever for actuating the valve, a diaphragm and pressure chamber communicating with the boiler for operating the lever, and a weight for the lever to regulate the amount of pressure necessary to move the valve.

My invention also comprehends details of construction which, together with the features above specified, will be better understood by reference to the drawings, in which:

Figure 1 is an elevation of a steam boiler and means for heating the same, embodying my invention; and Fig. 2 is a plan view of the lower part of the same with the boiler proper removed.

A is the boiler and B is the fire-box or base and which provides a heating chamber.

B' is a front or cover-plate, covering an opening B⁵ in the front of the base B and is supported upon lugs B⁴. This plate is also provided with vertical slotted portions B² to enable the plate B to fit down over the burner C and the igniting nozzle M and thereby prevent the entrance of air to the upper part of the chamber of the base B. The opening B⁵ below plate B' remains

open so as to provide the necessary additional air to the mixture of air and gas which pass from the gas burner.

C is the gas burner and may be of any construction desired, it being adapted to burn a mixture of air and gas in the well-known manner. D is a gas supply pipe for supplying gas to the burner C and C' is the air mixing device or nozzle. These parts may be of any suitable construction. The gas pipe D connects with the gas supply pipe E through a hand valve G and an automatic regulating valve F, the hand valve being preferably between the automatic valve F and the burner C.

P is a standard connecting with the outer end of the gas pipe and D is provided with a flanged base by which it may be secured to the floor for properly supporting the several valves and pipes.

L is a branch pipe leading from the gas pipe at any suitable position beyond the hand valve G and connects with the igniting burner N which has a control valve M. This nozzle N provides a flame for igniting the gas mixture from the burner C when the latter is turned on by the hand valve G.

If there is no steam pressure in the boiler, the flame from the burner C is made a maximum, by turning the hand valve G wide open. If the steam pressure rises above a predetermined amount, then the supply of gas is automatically controlled by the valve F and the regulator I. The construction of this regulator is as follows: A pressure chamber I³ is formed below a diaphragm I' and the said diaphragm is connected with a rod I² which moves vertically to raise and lower a lever H, which is pivoted at one end to the regulator I and at the other end to the regulating stem of the valve F. A weight K is adjustably secured to the lever H, so as to put any desired pressure upon the diaphragm I' and for normally opening the valve F. The regulator I is supported from the floor by a flanged standard R so that it has a fixed relation with the valve F. A steam pipe J leased from the boiler to the chamber I³ of the regulator whereby there is provided a pressure below the diaphragm I' equal to that in the boiler.

It will now be understood that whenever the pressure in the boiler rises above an amount which is predetermined, the diaphragm I' will be raised and the valve F

throttled to reduce the flow of the gas and thereby restrict the amount of heat given to the boiler so long as the pressure therein is maintained at or above the normal. If
 5 the pressure should fall below the normal pressure, then the weight K will depress the diaphragm I' and open the regulating valve F to a greater extent thereby supply-
 10 ing more gas to the burner and consequently increasing the heating of the boiler to raise its steam pressure. In this manner the apparatus is automatic and there is no danger of explosion from excess of steam pressure; and the apparatus, as a whole, is
 15 in such simple compact form that anyone of ordinary intelligence may operate it.

This invention is more particularly useful where small power is required for light manufacturing or other purposes and where
 20 more or less inexperienced persons are required to handle the apparatus.

This invention has great advantage from economy in the consumption of the gas required to heat the boiler, as no more gas is
 25 fed to the burner than is actually required to provide the necessary heat to meet the evaporation duty of the boiler at the predetermined pressure. While the economy of this method of handling the fuel, produces very economical results, it is not the
 30 only economical effect obtained. It is well known that variation of steam pressure materially shortens the life of a boiler. With
 35 this method, however, the tendency must be toward a lesser, never a greater pressure.

In the great majority of cases, where this method would be applicable, the variation of pressure would not change more than one pound at any time during its application. On this account there would scarcely be
 40 any limit to the life of a well constructed boiler.

Having now described my invention what I claim as new and desire to secure by Letters Patent, is:

The combination of a steam boiler, a gas burner for heating the same, a gas main for supplying gas to the burner, a hand valve in said gas main, an automatic regulating valve also in said gas main, an automatic
 45 steam actuated regulator out of alinement with the regulating valve for operating the said regulating valve to reduce the supplying of gas to the burner whenever the steam
 50 pressure in the boiler exceeds a predetermined amount, operative connecting means extending laterally between the regulating valve and steam actuated regulator, and independent standards having flanged bases
 55 for separately supporting the regulating device and the gas main from the floor whereby a fixed relation is had between the regulating device and the automatic regulating valve.

In testimony of which invention, I have
 60 hereunto set my hand.

WILLIAM KANE.

Witnesses:

R. M. HUNTER,
 R. M. KELLY.