



(12) **DEMANDE DE BREVET CANADIEN
CANADIAN PATENT APPLICATION**

(13) **A1**

(86) **Date de dépôt PCT/PCT Filing Date:** 2020/10/31
 (87) **Date publication PCT/PCT Publication Date:** 2021/10/07
 (85) **Entrée phase nationale/National Entry:** 2022/09/27
 (86) **N° demande PCT/PCT Application No.:** US 2020/058438
 (87) **N° publication PCT/PCT Publication No.:** 2021/201915
 (30) **Priorité/Priority:** 2020/03/30 (US16/834,916)

(51) **Cl.Int./Int.Cl. B65D 41/34** (2006.01)
 (71) **Demandeur/Applicant:**
THISCAP, INC., US
 (72) **Inventeur/Inventor:**
MAGUIRE, MICHAEL JOSEPH, US
 (74) **Agent:** RIDOUT & MAYBEE LLP

(54) **Titre : BOUCHON POUR RECIPIENT**
 (54) **Title: CAP FOR CONTAINER**

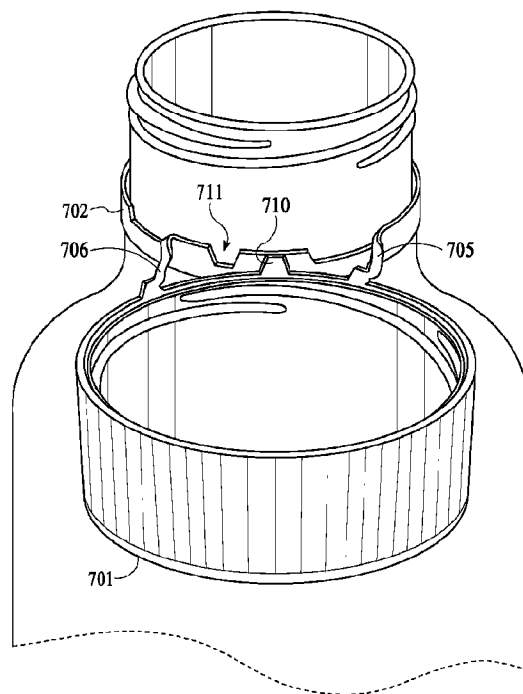

FIG. 34

(57) **Abrégé/Abstract:**

A cap for a container is formed so that the cap has a top plate and a circular sidewall. Two opposite sides of the circular sidewall circularly connect to each other, one periphery of the circular sidewall connecting to one surface of the top plate forming a closed end, and another periphery of the circular sidewall at an opposite side of the closed end forms an opened end. Incisions are in the circular sidewall. The incisions form a ring member located at the opened end of the cap separated from a main body of the cap by a first incision and a second incision between the opened end of the main body and the ring member.

Date Submitted: 2022/09/27

CA App. No.: 3173689

Abstract:

A cap for a container is formed so that the cap has a top plate and a circular sidewall. Two opposite sides of the circular sidewall circularly connect to each other, one periphery of the circular sidewall connecting to one surface of the top plate forming a closed end, and another periphery of the circular sidewall at an opposite side of the closed end forms an opened end. Incisions are in the circular sidewall. The incisions form a ring member located at the opened end of the cap separated from a main body of the cap by a first incision and a second incision between the opened end of the main body and the ring member.

CAP FOR CONTAINER

FIELD OF THE INVENTION

[0001] This application pertains to caps for containers and pertains specifically to caps that remain attached to the container after the container is opened.

BACKGROUND

[0002] In general, the cap of a conventional container is completely separated from its container once the container is opened. For that reason, it is easy for the separated cap to be dropped, accidentally disposed of and/or misplaced/lost. Moreover, the separated cap when dropped can easily become soiled by coming in to contact with the ground or other uncontrolled surfaces resulting in the cap becoming no longer reusable. Furthermore, the discarded or misplaced/lost separated caps are able to and will pollute the environment and cause additional environmental problems. Therefore, in order to solve these problems, the industry has developed a few caps that will remain connected to their containers while their containers are in an open state. These few caps are thereby prevented from being separated from their containers, dropped, accidentally discarded, misplaced/lost, soiled by contact with the ground or other uncontrolled surfaces or able to pollute the environment or cause additional environmental problems.

[0003] Nonetheless, the currently existing caps with the above-mentioned functions can use complex designs and complicated connecting structures that necessitate some difficult physical manipulation by the user to return the caps to a closed sealed state. Manufacture of caps with these structures can also be complex or expensive.

BRIEF DESCRIPTION OF THE DRAWINGS

[0004] FIG. 1 is a three-dimensional schematic diagram showing an embodiment of the cap for a container in accordance with an embodiment.

- [0005]** FIG. 2A-2G are schematic diagrams showing different embodiments of a cap for a container.
- [0006]** FIG. 3 is a three-dimensional schematic diagram showing an embodiment for a cap being separated from a container
- [0007]** FIG. 4 shows part of a manufacturing system used to engrave incision lines within a cap in accordance with an implementation.
- [0008]** FIG. 5 illustrates incision lines engraved within a cap in accordance with an implementation.
- [0009]** FIG. 6 shows spindles of a manufacturing system used to engrave incision lines within a cap in accordance with an implementation.
- [0010]** FIG. 7 shows blades used to engrave incision lines within a cap in accordance with an implementation.
- [0011]** FIG. 8, FIG. 9, FIG. 10, FIG. 11 and FIG. 12 show blade patterns for blades used to engrave incision lines within a cap in accordance with implementations.
- [0012]** FIG. 13, FIG. 14, FIG. 15 and FIG. 16 illustrate grooves placed within a spindle to aid in engraving incision lines in accordance with implementations.
- [0013]** FIG. 17, FIG. 18, FIG. 19, FIG. 20, FIG. 21, FIG. 22 and FIG. 23 illustrate a cap that after being removed from a container, may be held against the container in a flipped position in accordance with implementations.
- [0014]** FIG. 24, FIG. 25, FIG. 26 and FIG. 27 illustrate another cap that after being removed from a container, may be held against the container in a flipped position.
- [0015]** FIG. 28 shows an alternative pattern of incisions on a cap in accordance with an implementation.
- [0016]** FIG. 29, FIG. 30 and FIG. 31 show another alternative pattern of incisions on a cap in accordance with an implementation.
- [0017]** FIG. 32, FIG. 33 and FIG. 34 show another alternative pattern of incisions on a cap in accordance with an implementation.
- [0018]** FIG. 35, FIG. 36 and FIG. 37 show another alternative pattern of incisions on a cap in accordance with an implementation.
- [0019]** FIG. 38 shows another alternative pattern of incisions on a cap in accordance with an implementation.

[0020] FIG. 39 shows another alternative pattern of incisions on a cap in accordance with an implementation.

[0021] FIG. 40 shows another alternative pattern of incisions on a cap in accordance with an implementation.

DETAILED DESCRIPTION

[0022] FIG. 1 is a three-dimensional schematic diagram showing an embodiment of a cap for a container. As FIG. 1 shows, the cap 10 of the present example includes a main body 1 having a top plate 11 and a circular sidewall 12. The two opposite sides of the circular sidewall 12 circularly connect to each other. One periphery of the circular sidewall 12 connects to one surface of the top plate 11 forming a closed end 1'. The other periphery of the circular sidewall 12 at the opposite side of the closed end 1' forms an opened end 1" (shown in FIG. 3). The cap 10 of the present example also contains a ring member 2, which is located at the opened end 1" of the main body 1. The ring member 2 is separated from the main body 1 by penetration lines which can be formed as part of the formation of cap 10. For example, the penetration lines are formed as part of an injection molding process or other manufacturing process in which cap 10 is formed.

[0023] For example, penetration lines may also be formed by incision. While in the description below penetration lines are often referred to as incision lines, the penetration lines can be formed by methods other than incision. The ring member 2 is separated from the main body 1 by a first incision line 3 located in between the opened end 1" of the main body 1 and the ring member 2. The first incision line 3 possesses a plurality of connecting pins 31. The plurality of connecting pins 31 located along the first incision line 3 connect the main body 1 and the ring member 2 at the two sides of the first incision line 3. The two ends of the first incision line 3 are separated by a plurality of connecting portions 5. The plurality of connecting portions 5 connect the main body 1 and the ring member 2 together. Located at one side of the plurality of connecting portions 5 is a plurality of second incision lines 4. The plurality of second incision lines 4 are also located either on the main body 1 or the ring member 2. The two ends of the plurality of second incision lines 4 and itself are not connected. The plurality of second incision lines 4 do not overlap with the first incision line 3.

[0024] As FIG. 2A shows, in the present example, the plurality of connecting portions 5 are formed in between the first incision line 3 and the plurality of second incision lines 4. For example, the shape of the plurality of connecting portions 5 is not particularly limited. The shape of the plurality of the connecting portions 5 is depended on the shapes of the first incision line 3 and the plurality of second incision lines 4 located at the sides of the plurality of connecting portions 5. In the present example, the shape of the plurality of connecting portions 5 is cuboid (shown in FIG. 3). For example, the quantity of the plurality of connecting portions 5 is not particularly limited. However, in the present example, the quantity of the plurality of connecting portions 5 is 2. For example, the spacing between each of the plurality of connecting portions 5 is not particularly limited as well. However, in the present example, each of the plurality of connecting portions 5 is separated by parts of the plurality of second incision lines 4.

[0025] For example, the quantity of the plurality of second incision lines 4 is not particularly limited. However, in the present example, the quantity of the plurality of second incision lines 4 is 2. As FIG. 2A shows, only the main body 1 possesses the plurality of second incision lines 4. One of the two second incision lines 4 is connected to parts of the first incision line 3. Furthermore, parts of the plurality of second incision lines 4 are parallel to the first incision line 3.

[0026] For example, the first incision line 3 and the plurality of second incision lines 4 are not particularly limited. The first incision line 3 and the plurality of second incision lines 4 can individually be, for example, straight lines, curved lines, polylines, arc lines, or the combinations thereof. In the present example, the first incision line 3 is a straight line. The plurality of second incision lines 4 can also be more preferably be L-shaped lines, S-shaped lines, Z-shaped lines, or the combinations thereof. In the present example, the plurality of second incision lines 4 are Z-shaped lines. For example, the corners 41 of the plurality of second incision lines 4 are not particularly limited. The corners 41 of the plurality of second incision lines 4 are, for example, curved corners, chamfered corners, sharp corners, or the combinations thereof. In the present example, the corners 41 of the plurality of second incision lines 4 are curved corners.

[0027] For example, the first incision line 3 and the plurality of second incision lines 4 surround parts of the circular sidewall 12 or the ring member 2, but do not

fully surround the circular sidewall 12 or the ring member 2. The lengths of the first incision line 3 and the plurality of second incision lines 4 surrounded the circular sidewall 12 or the ring member 2 are not particularly limited. In the present example, the length of the first incision line 3 surrounded the circular sidewall 12 or the ring member 2 is longer than the lengths of each of the plurality of second incision lines 4 surrounded the circular sidewall 12 or the ring member 2; however, this can vary based on implementation.

[0028] FIG. 2B is a schematic diagram showing another embodiment of the cap for a container. The cap of the present example and the cap shown in FIG. 1 are the same except that the plurality of second incision lines 4 and the plurality of second incision lines 4 shown in FIG. 2A are opposite to each other. Nevertheless, the opening directions of the cap and that of the cap shown in FIG. 2A are still the same (both are in the anti-clockwise direction; that is rotation in the right direction in FIG. 2A or FIG. 2B).

[0029] FIG. 2C is a schematic diagram showing another embodiment of the cap for a container. The cap of the present example and the cap shown in FIG. 1 are the same except that only the ring member 2 possesses the plurality of second incision lines 4 and the plurality of second incision lines 4 surround less than 1/5 of the ring member 2.

[0030] FIG. 2D is a schematic diagram showing another embodiment of the cap for a container. The cap of the present example and the cap shown in FIG. 1 are the same except that the quantity of the plurality of second incision lines 4 is 1, the second incision line 4 extends from the main body 1 to the ring member 2 or from the ring member 2 to the main body 1, the second incision line 4 and the first incision line 3 are not connected, the corners 41 of the second incision line 4 (Z-shaped line) are sharp corners and the second incision line 4 surrounds less than 1/5 of the circular sidewall 12 and less than 1/5 of the ring member 2.

[0031] FIG. 2E is a schematic diagram showing another embodiment of the cap for a container. The cap of the present example and the cap shown in FIG. 1 are the same except that the plurality of second incision lines 4 are L-shaped lines and the corners 41 of these L-shaped lines are sharp corners.

[0032] FIG. 2F is a schematic diagram showing another embodiment of the cap for a container. The cap of the present example and the cap shown in FIG. 1 are

the same except that the plurality of second incision lines 4 and the first incision line 3 are not parallel to each other and the plurality of second incision lines 4 are S-shaped lines.

[0033] FIG. 2G is a schematic diagram showing another embodiment of the cap for a container. The cap of the present example and the cap shown in FIG. 2E are the same except that the corners 41 of the plurality of second incision lines 4 (L-shaped lines) are curved corners and one of the second incision lines 4 surrounds less than 1/2 of the circular sidewall 12.

[0034] FIG. 3 is a three-dimensional schematic diagram showing an embodiment of the cap for a container being separated from a container, wherein the cap shown can be any one of the caps of any one of the above-mentioned examples. Hereinafter, the practical application of the cap will be further described in detail using the cap shown in FIG. 1.

[0035] For example, the cap 10 provided can be used together with any conventional containers without any particular limitation as long as the cap 10 and the container 20 can be assembled together. For example, the shape of the cap 10 is not particularly limited. As shown in FIG. 3, the inner side of the cap is circular. For example, the shape of the container 20 is also not particularly limited as well. As shown in FIG. 3, the opening 210 of the container is a circular opening. For example, the container 20 is a round bottle or a round can. As shown in FIG. 3, the container 20 is a bottle with a circular opening.

[0036] The main body 1 of the cap 10 can control the opening and closing of the opening 210 of the container. As shown in FIG. 3, the inner side of the main body 1 has thread 110. Through a complementary thread structure 2100 at the outer side of the opening 210 of the container, the main body 1 can be screwed opened (in anti-clockwise direction) and screwed closed (not shown) (in clockwise direction) on the opening 210 of the container by rotation. For example, when the main body 1 of the cap 10 provided is screwed closed on the opening 210 of the container, the closed end 1' of the main body 1 will abut against the opening 210 of the container. Meanwhile, the opened end 1" of the main body 1 will face toward the opening 210 of the container and cover and fit on the opening 210 of the container. Consequently, the opening 210 of the container is in a closed state with the container 20 remaining sealed.

[0037] For example, the outer side of the main body 1 of the cap 10 provided can have a knurled portion 120. When the container 20 is to be opened, the knurled portion 120 can facilitate applying a force to rotate and separate the main body 1 and the ring member 2. For example, depending on the actual needs, the first incision line 3 disposed between the main body 1 and the ring member 2 of the cap 10 provided can have a plurality of connecting pins 31 to connect the main body 1 and the ring member 2. The shape, size, quantity and spacing of the plurality of connecting pins 31 are not particularly limited. When the size and quantity of the plurality of connecting pins 31 of the first incision line 3 are smaller and the spacing of the plurality of connecting pins 31 is larger, the force needed to break the plurality of connecting pins 31 is smaller. On the contrary, when the size and quantity of the plurality of connecting pins 31 of the first incision line 3 are larger and the spacing of the plurality of connecting pins 31 is smaller, the force needed to break the plurality of connecting pins 31 is larger. In the present example, the size and quantity of the plurality of connecting pins 31 of the first incision line 3 are smaller and the spacing of the plurality of connecting pins 31 is larger. In addition, the plurality of second incision lines 4 do not possess a plurality of connecting pins 31. Therefore, the force needed to break the plurality of connecting pins 31 is smaller. Subsequently, users can separate the main body 1 and the ring member 2 more easily; that is, the cap 10 can be opened from the opening 210 of the container more easily.

[0038] For example, when the main body 1 of the cap 10 has been screwed opened from the opening 210 of the container, the plurality of connecting portions 5 will connect the main body 1 and the ring member 2 together. Since the ring member 2 is fitted below a bulge portion 2200 of the opening 210 of the container; thus, the ring member 2 will not detach from the opening 210 of the container. As a result, the connection between the main body 1 separated from the opening 210 of the container with the ring member 2 will allow the main body 1 to still remain in a connected state with the container 20. Moreover, the plurality of connecting portions 5 can also allow the main body 1 to remain in an opened state. The plurality of connecting portions 5 will prevent the main body 1 from interfering the opening 210 of the container. The plurality of connecting portions 5 will also decrease the free movement of the main body 1. As a result, when

emptying the contents from the container 20, the plurality of connecting portions 5 can prevent the main body 1 from touching other objects due to its free movement. For example, when the container 20 is a water bottle, when users are drinking from the water bottle, the plurality of connecting portions 5 will prevent the main body 1 from touching the faces and any body parts of the users. In addition, the plurality of connecting portions 5 can also prevent the residual contents at the inner side of the main body 1 to spill out easily by decreasing the free movement of the main body 1. And since the ring member 2 fitted on the opening 210 of the container can freely rotate; hence, the plurality of connecting portions 5 will not be pulled off easily.

[0039] For example, the cap provided can be made by using any materials known in the art, wherein the material for the cap is, for example, plastic. The cap can be manufactured by any processes known in the art. For example, the manufacturing process of the cap is by injection molding. The first incision line and the plurality of second incision lines can be formed by any known methods. In all the above-mentioned examples, the first incision line and the plurality of second incision lines are formed by rotary cutting and the incisions are done by cutting tools or laser cutting.

[0040] FIG. 4 shows part of a manufacturing system 70 used to engrave incision lines within caps 73. Caps 73 are mounted on spindles 71 and supported by bases 72. Caps 73 are rotated as they pass a blade support structure 75 that holds blades 76, as illustrated by FIG. 5. The rotation of caps 73 against blades 76 result in incision lines engraved within caps 73.

[0041] FIG. 6 shows spindles 71 mounted on a spindle support 76.

[0042] FIG. 7 shows a path 121 that caps 73 travels along blades 76 in order to produce incision lines in caps 73.

[0043] FIG. 8, FIG. 9, FIG. 10, FIG. 11 and FIG. 12 show blade patterns for blades used to engrave incision lines within caps.

[0044] FIG. 8 shows a blade pattern 130 that uses a blade 131, a blade 132 and a blade 133 to produce incision lines in caps 73 that will result in connecting portions of each cap attaching the cap to a ring section. Blade 131 includes a first blade section and a second blade section located on a different plane than the first blade section. A third blade section forms a diagonal connection between the

first blade section and the second blade section. Likewise, blade 132 includes a first blade section and a second blade section located on a different plane than the first blade section. The first blade section is located on a same plane as the first blade section blade 131. The second blade section is located on a same plane as the second blade section blade 131. A third blade section forms a diagonal connection between the first blade section and the second blade section. Blade 133 is located on the same plane as the first blade section of blade 131. When the cap is mounted on a container, the connection portions assure the cap, through attachment to the ring, remains attached to the container even after the cap is removed the container opening, as described above. Notches in blade 131, blade 132 and blade 133 form bridge connection portions between the cap and the ring section. The bridge connection portions are broken when the cap is mounted on a container and the container is opened by unscrewing the cap.

[0045] FIG. 9 shows a blade pattern 140 that uses a blade 141, a blade 142, blade 143, a blade 144, a blade 145, a blade 146 and a blade 147 to produce incision lines in caps 73 that will result in connecting portions of each cap attaching the cap to a ring section. Blades 141, 144 and 147 are all located on a first plane. Blades 143 and 146 are both located on a second plane. Blades 142 and 145 are both located on a third plane between the first plane and the second plane. Blades 142 and 145 make smaller incisions than the other blades in the plurality of blades. Blade 142 and blade 145 are in a diagonal orientation between the first plane and the second plane. Alternatively, blade 142 and a blade 145 can be in a horizontal or a vertical orientation while located between the first plane and the second plane.

[0046] When a cap is mounted on a container, the connection portions assure the cap, through attachment to the ring, remains attached to the container even after the cap is removed the container opening, as described above. Notches in blade 141, blade 143, blade 146 and blade 147 form bridge connection portions between the cap and the ring section. The bridge connection portions are broken when the cap is mounted on a container and the container is opened by unscrewing the cap.

[0047] FIG. 10 shows a blade pattern 150 that uses a blade 151, a blade 152, blade 153, a blade 154 and a blade 155 to produce incision lines in caps 73 that

will result in connecting portions of each cap attaching the cap to a ring section. Blade 151 is located on a first plane and has a first gap and a second gap. Blade 153 and blade 155 are both located on a second plane. Blade 152 and blade 154 are both located on a third plane between the first plane and the second plane. Blade 152 is located near the first gap and blade 154 is located near the second gap. Blades 152 and 154 make smaller incisions than the other blades in this configuration. Blade 152 and blade 154 are in a diagonal orientation between the first plane and the second plane. Alternatively, blade 152 and a blade 154 can be in a horizontal or a vertical orientation while located between the first plane and the second plane. When the cap is mounted on a container, the connection portions assure the cap, through attachment to the ring, remains attached to the container even after the cap is removed the container opening, as described above. Notches in blade 151, blade 153 and blade 155 form bridge connection portions between the cap and the ring section. The bridge connection portions are broken when the cap is mounted on a container and the container is opened by unscrewing the cap.

[0048] FIG. 11 shows a blade pattern 160 that uses a blade 161, a blade 162, blade 163, a blade 164, a blade 165, a blade 166 and a blade 167 to produce incision lines in caps 73 that will result in connecting portions of each cap attaching the cap to a ring section. Blades 163, 164 and 166 are all located on a first plane. Blades 165 and 167 are both located on a second plane. Blades 161 and 162 are both located on a third plane between the first plane and the second plane. Blades 161 and 162 make smaller incisions than the other blades in the plurality of blades. Blade 161 and blade 162 are in a diagonal orientation between the first plane and the second plane. Alternatively, blade 161 and a blade 162 can be in a horizontal or a vertical orientation while located between the first plane and the second plane. When the cap is mounted on a container, the connection portions assure the cap, through attachment to the ring, remains attached to the container even after the cap is removed the container opening, as described above. Notches in blade 163, blade 164, blade 165, blade 166 and blade 167 form bridge connection portions between the cap and the ring section. The bridge connection portions are broken when the cap is mounted on a container and the container is opened by unscrewing the cap.

[0049] FIG. 12 shows a blade pattern 170 that uses a blade 171, a blade 172 and a blade 173 in a first plane. A blade 174 and a blade 175 are located in a second plane. A blade 176 and a blade 177 are in a horizontal orientation between the first plane and the second plane. Alternatively, blade 176 and a blade 177 can be in a diagonal or a vertical orientation while located between the first plane and the second plane. When the cap is mounted on a container, the connection portions assure the cap, through attachment to the ring, remains attached to the container even after the cap is removed the container opening, as described above. Notches in blade 163, blade 164, blade 165, blade 166 and blade 167 form bridge connection portions between the cap and the ring section. The bridge connection portions are broken when the cap is mounted on a container and the container is opened by unscrewing the cap.

[0050] The spindles can include grooves that mirror location of blades in order to aid in engraving incision lines in the caps. For example, FIG 13 shows a spindle 180 with a spindle head 181 that includes a groove 182 that is wide enough to accommodate all blades edges of a blade or a blade pattern.

[0051] FIG. 14 shows a spindle 200 with a spindle head 201 that includes a groove 202 and a groove 203 that each are wide enough to accommodate one blade edge from a blade or blade composite of a blade pattern. In the implementation shown in FIG 14, each "horizontal" blade edge has its own matching groove, where there are no grooves for vertical or diagonal blades or blade portions.

[0052] FIG. 15 shows a spindle 190 with a spindle head 191 that includes a groove 192, a groove 193, a groove 194 and a groove 195 that each are wide enough to accommodate one blade edge from a blade or blade portion as represented by blade edges of blade 196. In the implementation shown in FIG 15, each "horizontal" blade has its own matching groove and each vertical or diagonal blade or blade portion has its own matching groove.

[0053] FIG. 16 shows a spindle 290 with a spindle head 294 that includes a groove 291, a groove 292 and a groove 293 that each are wide enough to accommodate one blade or one blade portion from a blade pattern. For example, blade combination 295 has a blade edge 296, a blade edge 297 and a blade

edge 298. For example, groove 292 is present to allow for diagonal blades such as diagonal blades 152 and 154 shown in FIG. 10.

[0054] FIG. 17, FIG. 18, FIG. 19, FIG. 20, FIG. 21, FIG. 22 and FIG. 23 illustrate a cap 301 that after being removed from a container 300, may be held against container 300 in a flipped position. Specifically, in FIG. 17, a cap 301 is shown secured on a container 300. A first incision 303 and a second incision 304 form a connection portion 305 and a connection portion 306 between cap 301 and a ring member 302. In the embodiment shown in FIG. 17, a region 307 exists between a location where connection portion 305 is connected to ring member 302 and where connection portion 306 is connected to cap 301. A height of cap 301 and a diameter of cap 301 affect a length of region 307 and whether region 307 even exists, as dimensions of region 307, first incision 303 and second incision 304 are all dependent on sizing connection portion 305 and sizing connection portion 306 so that when cap 301 is removed from container 300, cap 301 may be held in a flipped position against container 300 by connection portion 305 and connection portion 306.

[0055] In the flipped position, a top surface 308 of cap 301 is held in a position where top surface 308 faces container 300. The length of connection portion 305 and the length of connection portion 306 are selected so that the elasticity of connection portion 305 and the elasticity of connection portion 306 allows cap 301 to be moved by a user into the flipped position against container 300 by stretching connection portion 305 and connection portion 306 and then the elasticity of connection portion 305 and the elasticity of connection portion 306 holds cap 301 in the flipped position against container 300 while a user drinks from the container.

[0056] When the user is temporarily done drinking from container 300, the elasticity of connection portion 305 and the elasticity of connection portion 306 allow cap 301 to be moved by a user out of the flipped position into an initial open position from which cap 301 can be screwed back onto container 300. For the case where a cap has a flip top design, the cap may be reattached by snapping the cap back onto the container.

[0057] FIG. 18 shows cap 301 after cap 301 has been unscrewed from container 300. Connection portion 305 and connection portion 306 hold cap 301

to ring member 302. Top surface 308 of cap 301 is facing away from container 300.

[0058] FIG. 19 shows a close up view of cap 301 after cap 301 has been unscrewed from container 300. Upon removal of cap 301 a lip 310 of cap 301 is exposed. Connection portion 305 and connection portion 306 hold cap 301 to ring member 302. Top surface 308 of cap 301 is facing away from container 300.

[0059] FIG. 20 shows a close up view of cap 301 where cap 301 has been pushed open from container 300. Connection portion 305 and connection portion 306 hold cap 301 to ring member 302. Until sufficient force is applied to cap 301, connection portion 305 and connection portion 306 are not long enough to let cap 301 flip past lip 310 of container 300. Because of the shortness of connection portion 305 and connection portion 306, lip 310 is in the way of cap 301 being placed in a flipped position where top surface 308 faces container 300. Once a user exerts more pressure, connection portion 305 and connection portion 306 stretch sufficiently to let cap 301 flip past lip 310 so that cap 301 is in the flipped position where top surface 308 faces container 300.

[0060] FIG. 21 and FIG. 22 show cap 301 in the flipped position where top surface 308 faces container 300. The elasticity of connection portion 305 and connection portion 306 hold cap 301 in the flipped position where top surface 308 faces container 300.

[0061] FIG. 23 is a top view illustrating that the elasticity of connection portion 305 and connection portion 306 hold cap 301 in the flipped position where top surface 308 faces container 300.

[0062] The height and diameter of a cap determine the length of connection portions necessary to allow a cap to be placed and held in a flipped position where the top surface of the cap faces the container. FIG. 24 and FIG. 25 show a container 400 with a cap 401 sized to fit over a lip 410 of container 400.

[0063] FIG. 24 and FIG. 25 show cap 401 having been unscrewed and pushed open from container 400. A connection portion 405 and a connection portion 406 hold cap 401 to a ring member 402. Until sufficient force is applied to cap 401, connection portion 405 and connection portion 406 are not long enough to let cap 401 flip past lip 410 of container 400, a ring member 402 and a ridge 411 of container 400. Because of the shortness of connection portion 405 and

connection portion 406, lip 410, ring member 402 and ridge 411 are in the way of cap 401 being placed in a flipped position where top surface 408 faces container 400. Once a user exerts more pressure, connection portion 405 and connection portion 406 stretch sufficiently to let cap 401 flip past lip 410, ring member 402 and ridge 411 so that cap 401 is in the flipped position where top surface 408 faces container 400.

[0064] FIG. 26 shows cap 401 in the flipped position where top surface 408 faces container 400. The elasticity of connection portion 405 and connection portion 406 hold cap 401 in the flipped position where top surface 408 faces container 400.

[0065] FIG. 27 is a top view illustrating that the elasticity of connection portion 405 and connection portion 406 hold cap 401 in the flipped position where top surface 408 faces container 400.

[0066] The incisions may be inverted. For example, in FIG. 28 shows a cap 501 is shown secured on a container 500. A first incision 503 and a second incision 504 form a connection portion 505 and a connection portion 506 between cap 501 and a ring member 502. In the embodiment shown in FIG. 17, a region 507 exists between a location where connection portion 505 is connected to ring member 502 and where connection portion 506 is connected to cap 501. A height of cap 501 and a diameter of cap 501 affect a length of region 507 and whether region 507 even exists, as dimensions of region 507, first incision 503 and second incision 504 are all dependent on sizing connection portion 505 and sizing connection portion 506 so that when cap 501 is removed from container 500, cap 501 may be held in a flipped position against container 500 by connection portion 505 and connection portion 506.

[0067] Incisions can extend into the cap to make it easier for the cap to flip into the flipped position. For example, FIG. 29 shows a cap 601 on a container 600. FIG 30 shows cap 601 having been unscrewed and pushed open from container 600. A connection portion 605 and a connection portion 606 hold cap 601 to a ring member 602. Incisions to form connector portion 605 extend into cap 601. Incisions to form connector portion 606 extend into cap 601.

[0068] Until sufficient force is applied to cap 601, connection portion 605 and connection portion 606 are not long enough to let cap 601 flip past a lip 610 of the

container. Once a user exerts more pressure, connection portion 605 and connection portion 606 stretch sufficiently to let cap 601 flip past the lip.

[0069] FIG. 31 shows cap 601 in the flipped position where top surface 608 faces in a downward direction. The elasticity of connection portion 605 and connection portion 606 hold cap 601 in a flipped position where top surface 608 faces in a downward direction. The connection location of connector portion 605 and cap 601 at the bottom of a notch 612 and the connection location of connector portion 606 and cap 601 at the bottom of a notch 613 results in less stretching of connector portion 605 and connector portion 606 to place cap 601 into the flipped position. This means it takes less force, and is therefore easier, to place cap 601 into the flipped position. Alternatively, cap 601 can be placed in a flipped position where top surface 608 faces container 600.

[0070] A tab extending from the cap can be added in a shape that holds the cap in the flipped position. For example, FIG. 32 shows a cap 701 with a top surface 708 on a container 700. The two incision lines outline a connection portion 705, a connection portion 706 and a tab 710 as shown. Tab 710 extends into a gap 711 of a ring member 702.

[0071] FIG. 33 shows cap 701 being unscrewed and pushed open from container 700. Connection portion 705 and connection portion 706 hold cap 701 to ring member 702.

[0072] FIG. 34 shows cap 701 in the flipped position where top surface 708 faces in a downward direction. The elasticity of connection portion 705 and connection portion 706 plus the shape and location of tab 710 hold cap 701 in a flipped position where top surface 708 faces in a downward direction.

[0073] FIG. 35 illustrates an improved incision pattern that simplifies manufacture and improves operation. For example, FIG. 35 shows a cap 801 on a container 800. Cap 801 has a top surface 808 and a circular sidewall 813. Two incisions outline a connection portion 805, a connection portion 806, a tab 810, a tab 812 and a tab 816 as shown. The first incision includes an incision section 821, an incision section 822, an incision section 823, an incision section 824, an incision section 825, an incision section 826 and an incision section 827. The second incision includes an incision section 828, an incision section 829, an incision section 830, an incision section 831, an incision section 832, an incision

section 833 and an incision section 834. While connecting pins are not specifically shown in FIG.35, they may be included along the first incision and the second incision, as described above in other implementations.

[0074] Connection portion 805, connection portion 806, tab 810, tab 812 and tab 816 are all formed between the same two incision planes. The first incision plane is delineated by incision section 821 and incision section 827 of the first incision and by incision section 828 and incision section 832 of the second incision, which are all incision sections placed on the first incision plane. The second incision plane is delineated by incision section 823 and incision section 825 of the first incision and by incision section 830 and incision section 834 of the second incision, which are all incision sections placed on the second incision plane.

[0075] The boundaries of connection portion 806 are defined by incision section 822 and incision section 823 of the first incision and by incision section 828 and incision section 829 of the second incision.

[0076] The boundaries of connection portion 805 are defined by incision section 826 and incision section 827 of the first incision and by incision section 833 and incision section 834 of the second incision.

[0077] The boundaries of tab 810 are defined by incision section 829, incision section 830 and incision section 831 of the second incision. The boundaries of tab 812 are defined by incision section 824, incision section 825 and incision section 826 of the first incision. The boundaries of tab 816 are defined by incision section 832, incision section 833 and incision section 834 of the second incision.

[0078] The incision pattern shown in FIG. 35 has several advantages over the incision shown in FIG. 32. For example, as shown in FIG. 32, while connecting portion 705 and connecting portion 706 are formed between two incision planes, tab 710 extends below these incision plane requiring another plane of blades to be used manufacture of cap 801.

[0079] This can be understood by FIG. 9, which shows blades 141, 144 and 147 are all located on a first plane, blades 143 and 146 are both located on a second plane and blades 142 and 145 are both located on a third plane. Like the blade configuration shown in FIG. 9, the incision pattern shown in FIG. 32 requires blades placed in three different planes. However, the incision pattern

shown in FIG. 35, allows the elimination of one of the planes of blades, so that only two of the planes of blades are required.

[0080] Another advantage of the incision pattern can be understood by considering FIG. 36. FIG. 36 shows cap 801 being unscrewed and pushed open from container 800. Connection portion 805 and connection portion 806 hold cap 801 to ring member 802. Removal of tab 810 leaves a gap 811 in a ring member 802. Removal of tab 812 leaves a gap 813 in ring member 802.

[0081] As shown in FIG. 36, both sides of connection portion 806 extend out of the second incision plane as delineated by incision section 823 of the first incision and by incision section 830 of the second incision. Likewise, both sides of connection portion 805 extend out of the second incision plane as delineated by incision section 825 of the first incision and by incision section 834 of the second incision.

[0082] In incision pattern shown in Figure 33, however, the sides of connection portion 705 and connection portion 706 extend out of different incision planes. This effects the aesthetics and optimal function of connection portion 705 and connection portion 706. The optional function is further illustrated by Figure 37.

[0083] FIG. 37 shows cap 801 in the flipped position where top surface 808 faces in a downward direction. In the flipped position, tab 810 of cap 801 aligns to rest on tab 816 of ring member 802. The elasticity of connection portion 805 and connection portion 806 plus the shape and location of tab 810 hold cap 801 in a flipped position where top surface 808 faces in a downward direction. As shown in Figure 37, because both sides of connection portion 806 extend out of the second incision plane, connection portion 806 is able to fold over and extend out flat from an intersection area 814 of ring member 802. Likewise, because both sides of connection portion 805 extend out of the second incision plane, connection portion 805 is able to fold over and extend out flat from an intersection area 815 of ring member 802. Compare this to Figure 34 where sides of connection portion 706 extends out of from ring member 702 on two different incision planes resulting in a looping effect where connection portion 706 connects to ring member 702. Likewise, where sides of connection portion 705 extends out of from ring member 702 on two different incision planes resulting in a looping effect where connection portion 705 connects to ring member 702. This

looping effect increases the effort needed to remove and flip cap 701. Removing this source of tension, as is accomplished by the design shown in FIG. 35 and FIG 37.

[0084] Another way tension is reduced when elevating (e.g. by unscrewing) cap 801 in the system shown in Figure 36 is that connecting portion 805 and connection portion 806 are at parallel angles during the time cap 808 is separated and elevated from ring member 802. This feature of parallel angle of connection portion 805 and connection portion 806 is also present in other embodiments such as shown in FIG 3, FIG. 18 and FIG. 33.

[0085] Further, because both connection portion 806 and connection portion 805 fold over and extend out flat from ring member 802, this allows ring member to have reduced width, lowering the location of flipped cap 801 relative to container 800. Tab 810 therefore can have a lower profile, as shown in Figure 37 as compared to tab 710 shown in Figure 34. The reduced profile (i.e. lower height) of tab 810 allows for less tension on connecting portion 805 and connecting portion 806 when flipping and flipping back allowing connection portion 806 and connection portion 805 to be shortened.

[0086] While the incision pattern shown in Figure 35 allows for all the above-described advantages, similar incision patterns can also be used to accomplish the same end result.

[0087] For example, FIG. 38 shows a cap 841 on a container 840. Cap 841 has a top surface 848 and a circular sidewall 843. Two incisions outline a connection portion 845, a connection portion 846, a tab 865, a tab 866 and a tab 867 as shown. The first incision includes an incision section 851, an incision section 852, an incision section 853, an incision section 854, an incision section 855, an incision section 856 and an incision section 857. The second incision includes an incision section 858, an incision section 859, an incision section 860, an incision section 861, an incision section 862, an incision section 863 and an incision section 864. While connecting pins are not specifically shown in FIG.38, they may be included along the first incision and the second incision, as described above in other implementations.

[0088] Connection portion 845, connection portion 846, tab 865, tab 866 and tab 867 are all formed between the same two incision planes. The first incision

plane is delineated by incision section 851 and incision section 855 of the first incision and by incision section 858 and incision section 862 of the second incision, which are all incision sections placed on the first incision plane. The second incision plane is delineated by incision section 853 and incision section 857 of the first incision and by incision section 864 and incision section 867 of the second incision, which are all incision sections placed on the second incision plane.

[0089] The boundaries of connection portion 846 are defined by incision section 851 and incision section 852 of the first incision and by incision section 863 and incision section 864 of the second incision.

[0090] The boundaries of connection portion 845 are defined by incision section 856 and incision section 857 of the first incision and incision section 858 and incision section 859 of the second incision.

[0091] The boundaries of tab 865 are defined by incision section 861, incision section 862 and incision section 863 of the second incision. The boundaries of tab 866 are defined by incision section 859, incision section 860 and incision section 861 of the second incision. The boundaries of tab 867 are defined by incision section 852, incision section 853 and incision section 854 of the first incision.

[0092] In the flipped position, tab 865 of cap 841 aligns to rest on tab 860 of ring member 842. In some implementations, tab 867 can be omitted by omitting incision sections 852, 853 and 854 and extending incision section 851 to connect directly with incision section 855.

[0093] In another example, FIG. 39 shows a cap 871 on a container 870. Cap 871 has a top surface 878 and a circular sidewall 873. Two incisions outline a connection portion 875, a connection portion 876, a tab 895, a tab 896 and a tab 897 as shown. The first incision includes an incision section 881, an incision section 882, an incision section 883, an incision section 884, an incision section 885 and an incision section 886. The second incision includes an incision section 887, an incision section 888, an incision section 889, an incision section 890 and an incision section 891. While connecting pins are not specifically shown in FIG.39, they may be included along the first incision and the second incision, as described above in other implementations.

[0094] Connection portion 875, connection portion 876, tab 895, tab 896 and tab 897 are all formed between the same two incision planes. The first incision plane is delineated by incision section 881 of the first incision and by incision section 887 of the second incision, which are all incision sections placed on the first incision plane. The second incision plane is delineated by incision section 883 and incision section 886 of the first incision and by incision section 891 of the second incision, which are all incision sections placed on the second incision plane.

[0095] The boundaries of connection portion 876 are defined by incision section 881 and incision section 882 of the first incision and by incision section 890 and incision section 891 of the second incision.

[0096] The boundaries of connection portion 875 are defined by incision section 885 and incision section 886 of the first incision and incision section 887 and incision section 888 of the second incision.

[0097] The boundaries of tab 895 are defined by incision section 889 and incision section 890 of the second incision. The boundaries of tab 896 are defined by incision section 888 and incision section 889 of the second incision. The boundaries of tab 897 are defined by incision section 884 and incision section 885 of the first incision.

[0098] In the flipped position, tab 895 of cap 871 aligns to rest on tab 896 of ring member 872. In some implementations, tab 897 can be omitted by omitting incision sections 884 and 885 and extending incision section 883 to connect directly with incision section 886.

[0099] In another example, FIG. 40 shows a cap 901 on a container 900. Cap 901 has a top surface 908 and a circular sidewall 903. Two incisions outline a connection portion 905, a connection portion 906, a tab 925, a tab 926 and a tab 927 as shown. The first incision includes an incision section 911, an incision section 912, an incision section 913, an incision section 914, an incision section 915 and an incision section 916. The second incision includes an incision section 920, an incision section 918, an incision section 919, an incision section 920, an incision section 921 and an incision section 922. While connecting pins are not specifically shown in FIG.39, they may be included along the first incision and the second incision, as described above in other implementations.

[00100] Connection portion 905, connection portion 906, tab 925, tab 926 and tab 927 are all formed between the same two incision planes. The first incision plane is delineated by incision section 911 of the first incision and by incision section 917 of the second incision, which are all incision sections placed on the first incision plane. The second incision plane is delineated by incision section 913 and incision section 916 of the first incision and by incision section 919 and incision section 922 of the second incision, which are all incision sections placed on the second incision plane.

[00101] The boundaries of connection portion 906 are defined by incision section 911 and incision section 912 of the first incision and by incision section 921 and incision section 922 of the second incision.

[00102] The boundaries of connection portion 905 are defined by incision section 915 and incision section 916 of the first incision and incision section 917 and incision section 918 of the second incision.

[00103] The boundaries of tab 925 are defined by incision section 920 and incision section 921 of the second incision. The boundaries of tab 926 are defined by incision section 918, incision section 919 and incision section 920 of the second incision. The boundaries of tab 927 are defined by incision section 914 and incision section 915 of the first incision.

[00104] In the flipped position, tab 925 of cap 901 aligns to rest on tab 926 of ring member 902. In some implementations, tab 927 can be omitted by omitting incision sections 914 and 915 and extending incision section 913 to connect directly with incision section 916.

[00105] There are certain common features to the embodiments shown in FIG. 35, FIG. 38, FIG. 39 and FIG. 40. For example, and the tabs and all the connection portions are formed between a first incision plane and a second incision plane.

[00106] Also, both sides of the connection portions extend to the base of the first incision plane. This is accomplished by the addition of incision sections at the base of each connection portion that extends to the first incision plane. For example, in the embodiment shown in FIG. 35, incision section 829 at the base of connecting portion 806 extends from incision section 828 on the second incision plane to the first incision plane to connect with incision section 830. Likewise,

incision section 826 at the base of connecting portion 805 extends from incision section 827 on the second incision plane to the first incision plane to connect with incision section 825.

[00107] For the embodiment shown in FIG. 38, incision section 863 at the base of connecting portion 846 extends from incision section 864 on the second incision plane to the first incision plane to connect with incision section 863. Likewise, incision section 856 at the base of connecting portion 845 extends from incision section 857 on the second incision plane to the first incision plane to connect with incision section 855.

[00108] For the embodiment shown in FIG. 39, incision section 890 at the base of connecting portion 876 extends from incision section 891 on the second incision plane to the first incision plane to connect with incision section 889. Likewise, incision section 885 at the base of connecting portion 875 extends from incision section 886 on the second incision plane to the first incision plane to connect with incision section 884.

[00109] For the embodiment shown in FIG. 40, incision section 921 at the base of connecting portion 906 extends from incision section 922 on the second incision plane to the first incision plane to connect with incision section 920. Likewise, incision section 915 at the base of connecting portion 905 extends from incision section 916 on the second incision plane to the first incision plane to connect with incision section 914.

CLAIMS

What is claimed is:

1. A cap for a container, comprising:

a main body having a top plate and a circular sidewall, the top plate having a top surface, wherein two opposite sides of the circular sidewall circularly connect to each other, one periphery of the circular sidewall connects to one surface of the top plate forming a closed end, and the other periphery of the circular sidewall at the opposite side of the closed end forms an opened end;

a ring member, which is located at the opened end of the main body;

a first incision between the opened end of the main body and the ring member, the first incision having a first end and a second end, the first end being separated from the second end, the first incision including:

a first incision section,

a second incision section, connected to the first incision section,

a third incision section, connected to the second incision section,

a fourth incision section, connected to the first incision section,

a fifth incision section, connected to the fourth incision section,

a sixth incision section, connected to the fifth incision section, and

a seventh incision section, connected to the sixth incision section;

and

a second incision located on the main body or the ring member, the second incision having a first end and a second end, the first end of the second incision being separated from the second end of the second incision, the second incision including:

an eighth incision section,

a ninth incision section, connected to the eighth incision section,

a tenth incision section, connected to the ninth incision section,

an eleventh incision section, connected to the tenth incision section,

a twelfth incision section, connected to the eleventh incision section,

a thirteenth incision section, connected to the twelfth incision

section, and

a fourteenth incision section, connected to the thirteenth incision

section;

wherein the first incision and the second incision do not intersect and are configured so that when the cap is on the container and the cap is unscrewed, the main body separates from the ring member except for a first connection portion formed between the third incision section and the eighth incision section and except for a second connecting portion formed between the seventh incision section and the fourteenth incision section;

wherein the first incision section, the seventh incision section, the eighth incision section and the twelfth incision section are all located on a first incision plane; and

wherein the third incision section, the tenth incision section and the fourteenth incision section are all located on a second incision plane.

2. The cap as claimed in claim 1, wherein a location and length of the first incision and the second incision are selected so that a length of the first connecting portion and a length of the second connecting portion are long enough to allow a user to, by an application of force, stretch the first connecting portion and the second connecting portion sufficiently to allow the main body to be placed into a flipped position where the top surface of the top plate faces downward, and so that the length of the first connecting portion and the length of the second connecting portion are short enough that the elasticity of the first connecting portion and the second connecting portion hold the main body in the flipped position once the user places the main body in the flipped position.

3. The cap as claimed in claim 1, wherein the first incision includes a plurality of connector pins.

4. A cap for a container, comprising:

a main body having a top plate and a circular sidewall, the top plate having a top surface, wherein two opposite sides of the circular sidewall circularly connect to each other, one periphery of the circular sidewall connects to one surface of the top plate forming a closed end, and the other periphery of the circular sidewall at the opposite side of the closed end forms an opened end;

a ring member, which is located at the opened end of the main body;

a first incision between the opened end of the main body and the ring member, the first incision having a first end and a second end, the first end being separated from the second end, the first incision including:

- a first incision section,
- a second incision section, connected to the first incision section,
- a third incision section, connected to the second incision section,
- a fourth incision section, connected to the first incision section,
- a fifth incision section, connected to the fourth incision section,
- a sixth incision section, connected to the fifth incision section, and
- a seventh incision section, connected to the sixth incision section;

and

a second incision located on the main body or the ring member, the second incision having a first end and a second end, the first end of the second incision being separated from the second end of the second incision, the second incision including:

- an eighth incision section,
- a ninth incision section, connected to the eighth incision section,
- a tenth incision section, connected to the ninth incision section,
- an eleventh incision section, connected to the tenth incision section,
- a twelfth incision section, connected to the eleventh incision section,
- a thirteenth incision section, connected to the twelfth incision

section, and

- a fourteenth incision section, connected to the thirteenth incision section;

wherein the first incision and the second incision do not intersect and are configured so that when the cap is on the container and the cap is unscrewed, the main body separates from the ring member except for a first connection portion formed between the third incision section and the eighth incision section and except for a second connecting portion formed between the seventh incision section and the fourteenth incision section;

wherein the ninth incision section, the tenth incision section and the eleventh incision section form a first tab connected to the circular sidewall so that that when the cap is unscrewed, the first tab juts out from the circular sidewall and

the ring member includes a first notch that was formerly occupied by the first tab, and so that when the cap is screwed shut, the first tab is located within the first notch; and

wherein the ninth incision section, the tenth incision section and the eleventh incision section form a second tab connected to the circular sidewall so that that when the cap is unscrewed, the second tab juts out from the circular sidewall and the ring member includes a second notch that was formerly occupied by the second tab, and so that when the cap is screwed shut, the second tab is located within the second notch.

5. The cap as claimed in claim 4, wherein a location and length of the first incision and the second incision are selected so that a length of the first connecting portion and a length of the second connecting portion are long enough to allow a user to, by an application of force, stretch the first connecting portion and the second connecting portion sufficiently to allow the main body to be placed into a flipped position where the top surface of the top plate faces downward, and so that the length of the first connecting portion and the length of the second connecting portion are short enough that the elasticity of the first connecting portion and the second connecting portion hold the main body in the flipped position once the user places the main body in the flipped position.

6. The cap as claimed in claim 4, wherein the first incision includes a plurality of connector pins.

7. A method for providing a cap for a container, comprising:

forming a main body having a top plate with a top surface and a circular sidewall, where two opposite sides of the circular sidewall circularly connect to each other and where one periphery of the circular sidewall connects to one surface of the top plate forming a closed end so that the other periphery of the circular sidewall at the opposite side of the closed end forms an opened end;

forming a ring member located at the opened end of the main body; and

separating the ring member from the main body by a first incision and by a second incision, wherein a location and length of the first incision and the second

incision are selected so that when the cap is on the container and the cap is unscrewed, the main body separates from the ring member except for a first connection portion and a second connecting portion formed by the first incision and the second incision;

a first incision between the opened end of the main body and the ring member, the first incision having a first end and a second end, the first end being separated from the second end, the first incision including:

a first incision section,
a second incision section, connected to the first incision section,
a third incision section, connected to the second incision section,
a fourth incision section, connected to the first incision section,
a fifth incision section, connected to the fourth incision section,
a sixth incision section, connected to the fifth incision section, and
a seventh incision section, connected to the sixth incision section;

and

a second incision located on the main body or the ring member, the second incision having a first end and a second end, the first end of the second incision being separated from the second end of the second incision, the second incision including:

an eighth incision section,
a ninth incision section, connected to the eighth incision section,
a tenth incision section, connected to the ninth incision section,
an eleventh incision section, connected to the tenth incision section,
a twelfth incision section, connected to the eleventh incision section,
a thirteenth incision section, connected to the twelfth incision

section, and

a fourteenth incision section, connected to the thirteenth incision section;

wherein the first connection portion is formed between the third incision section and the eighth incision section;

wherein the second connecting portion is formed between the seventh incision section and the fourteenth incision section;

wherein the first incision section, the seventh incision section, the eight

incision section and the twelfth incision section are all located on a first incision plane; and

wherein the third incision section, the tenth incision section and the fourteenth incision section are all located on a second incision plane.

8. The method of claim 7, wherein when the main body separates from the ring member a length of the first connecting portion and a length of the second connecting portion are long enough to allow a user to, by an application of force, stretch the first connecting portion and the second connecting portion sufficiently to allow the main body to be placed into a flipped position where the top surface of the top plate faces downward, so that the length of the first connecting portion and the length of the second connecting portion are short enough that the elasticity of the first connecting portion and the second connecting portion hold the main body in the flipped position once the user places the main body in the flipped position.

9. The method of claim 7, wherein the first incision includes a plurality of connector pins.

10. The method of claim 7, wherein the first incision includes a portion that penetrates the ring member so that when the cap is unscrewed, a tab connected to the circular sidewall juts out from the circular sidewall and the ring member includes a notch that was formerly occupied by the tab, and when the cap is screwed shut, the tab is located within the notch, the tab having a diagonal sidewall shaped to not interfere with unscrewing the cap.

11. A cap for a container, comprising:

a main body having a top plate and a circular sidewall, the top plate having a top surface, wherein two opposite sides of the circular sidewall circularly connect to each other, one periphery of the circular sidewall connects to one surface of the top plate forming a closed end, and the other periphery of the circular sidewall at the opposite side of the closed end forms an opened end;

a ring member, which is located at the opened end of the main body;

a first incision between the opened end of the main body and the ring member, the first incision having a first end and a second end, the first end being separated from the second end, the first incision comprising a first plurality of incision sections, connected in series;

a second incision located on the main body or the ring member, the second incision having a first end and a second end, the first end of the second incision being separated from the second end of the second incision, the second incision including comprising a second plurality of incision sections, connected in series:

wherein the first incision and the second incision do not intersect and are configured so that when the cap is on the container and the cap is unscrewed, the main body separates from the ring member except for a first connection portion formed between a first incision section from the first plurality of incision sections and a first incision section from the second plurality of incision sections and except for a second connecting portion formed between a second incision section from the first plurality of incision sections and a second incision section from the second plurality of incision sections;

wherein the first incision section from the first plurality of incision sections and the second incision section from the second plurality of incision sections are located on a first incision plane;

wherein the second incision section from the first plurality of incision sections and the first incision section from the second plurality of incision sections are located on a second incision plane

wherein a first tab extending from the ring member is formed between the first incision plane and the second incision plane by the first incision and the second incision;

wherein a second tab extending from the circular sidewall is formed between the first incision plane and the second incision plane by the first incision and the second incision, the first tab and the second tab being situated so that when the cap is in an opened and in a flipped position, the second tab rests on top of the first tab;

wherein a base of the first connection portion is outlined by a third incision section from the second plurality of incision sections, which extends from the first

incision section from the second plurality of incision sections to the first incision plane; and

wherein a base of the second connection portion is outlined by a third incision section from the first plurality of incision sections, which extends from the second incision section from the second plurality of incision sections to the first incision plane.

12. The cap as claimed in claim 11, wherein a location and length of the first incision and the second incision are selected so that a length of the first connecting portion and a length of the second connecting portion are long enough to allow a user to, by an application of force, stretch the first connecting portion and the second connecting portion sufficiently to allow the main body to be placed into the flipped position where the top surface of the top plate faces downward, and so that the length of the first connecting portion and the length of the second connecting portion are short enough that the elasticity of the first connecting portion and the second connecting portion hold the main body in the flipped position once the user places the main body in the flipped position.

13. The cap as claimed in claim 11, wherein the first incision includes a plurality of connector pins.

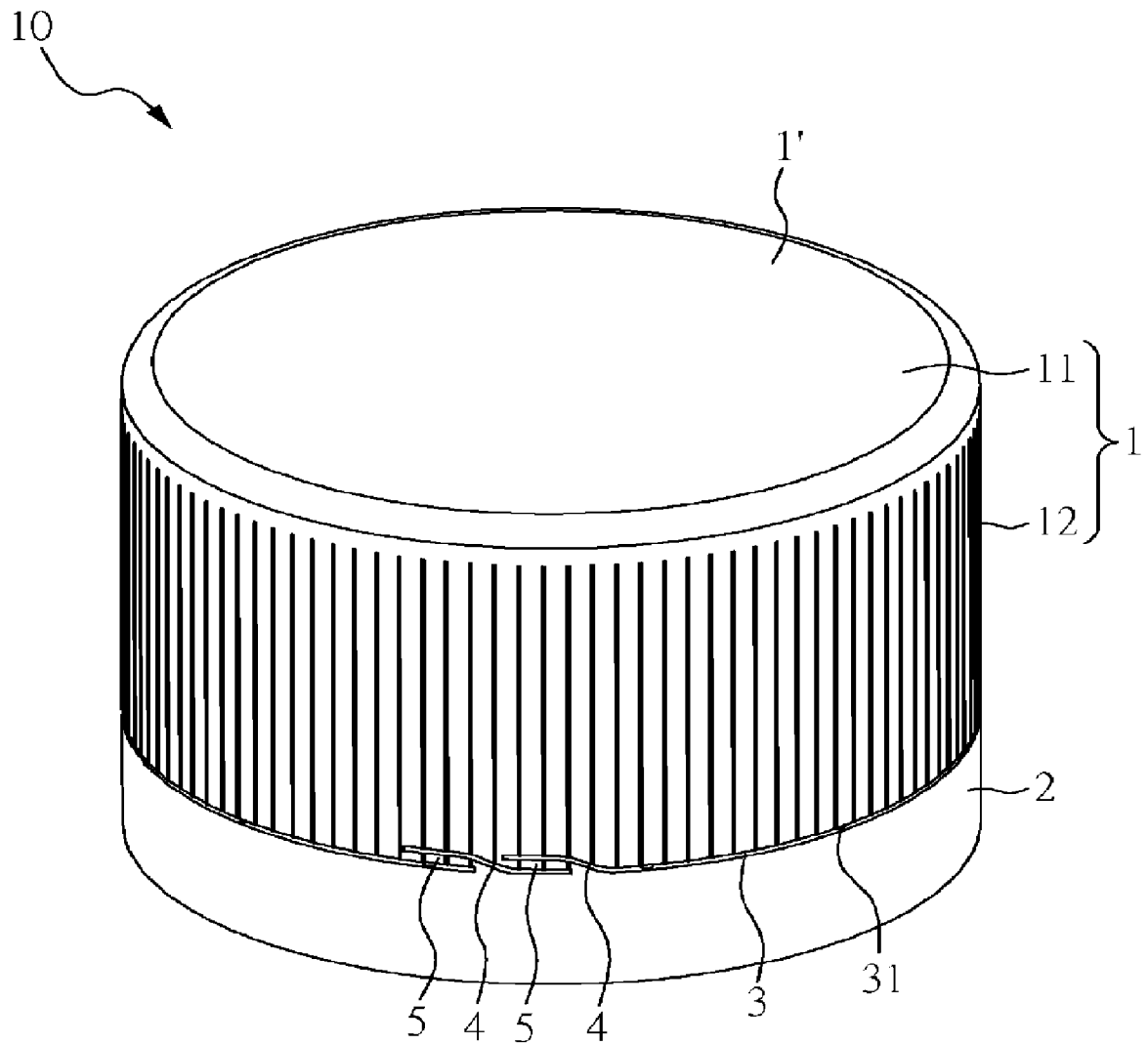

FIG. 1

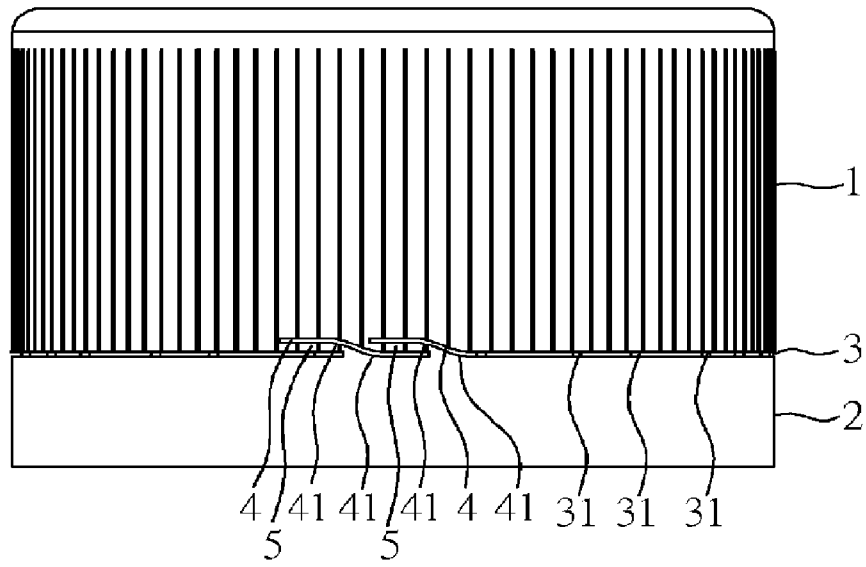

FIG. 2A

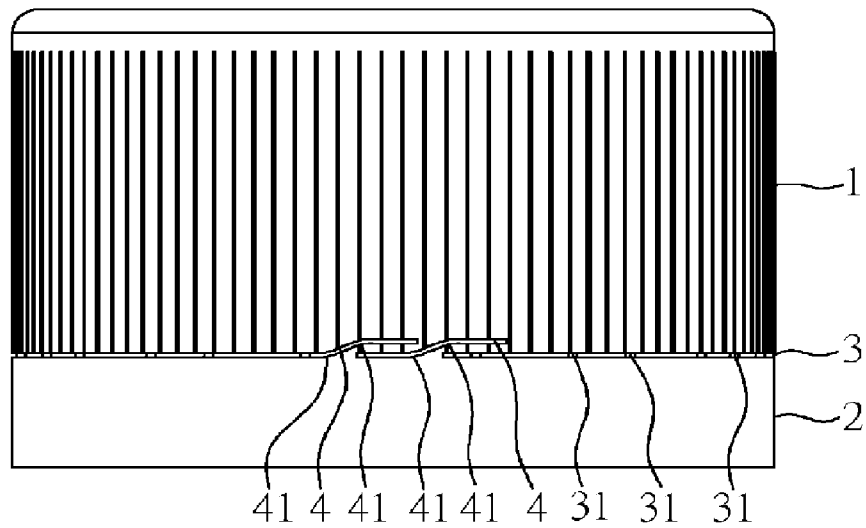

FIG. 2B

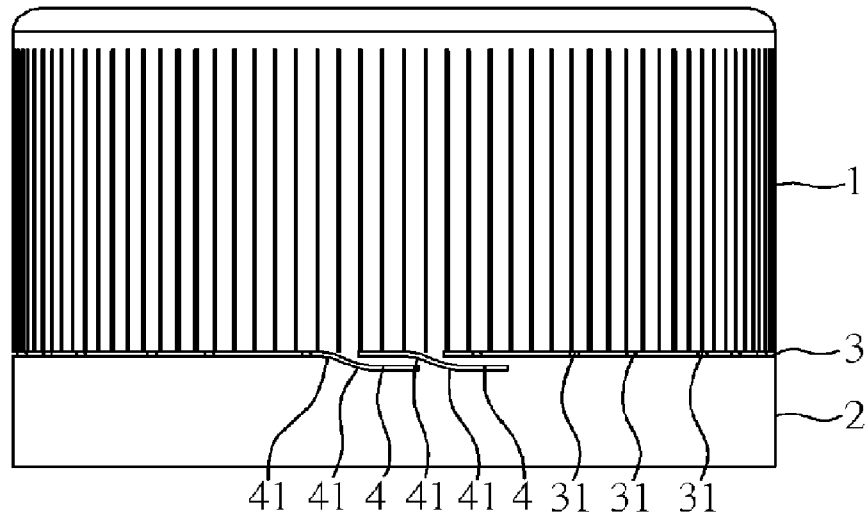

FIG. 2C

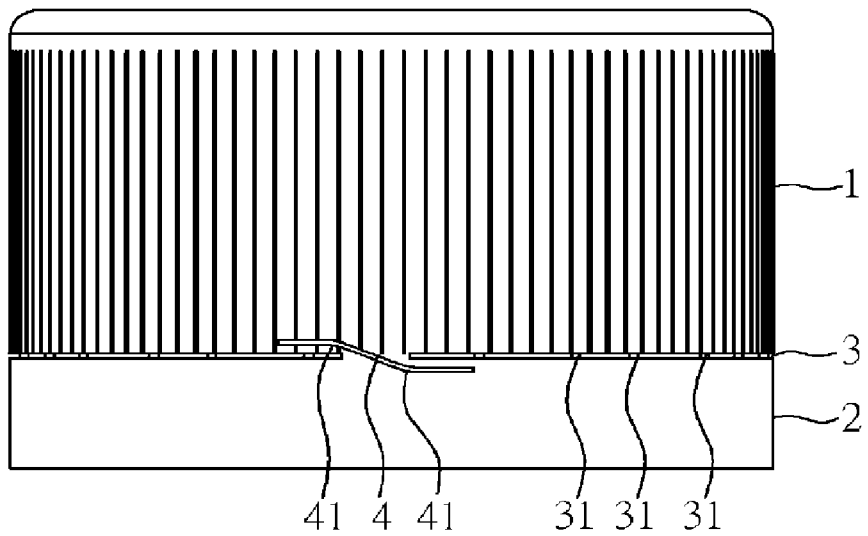

FIG. 2D

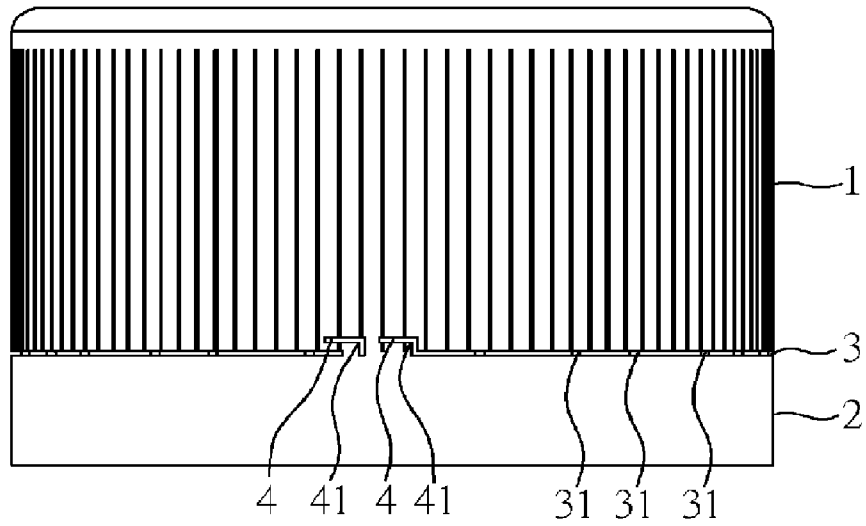

FIG. 2E

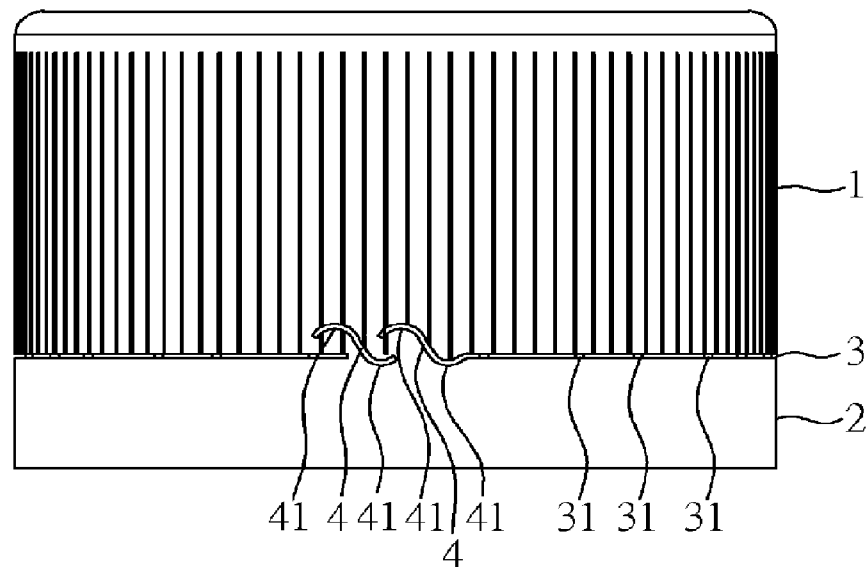

FIG. 2F

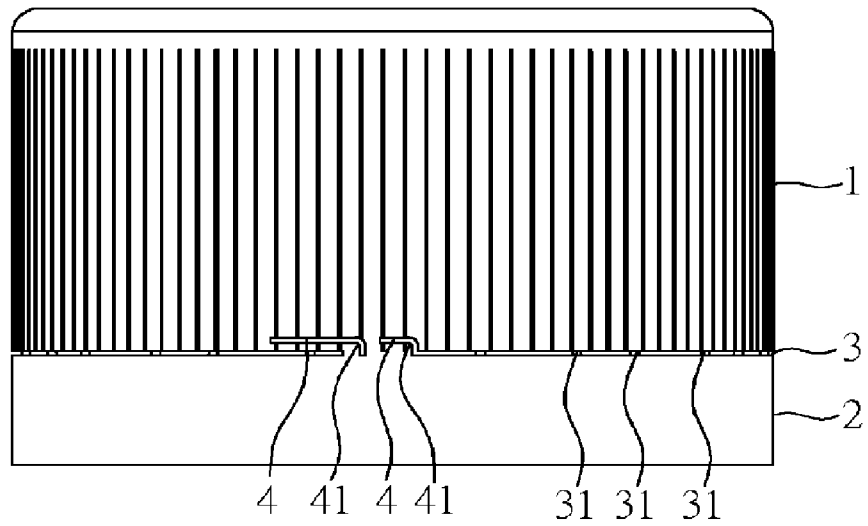

FIG. 2G

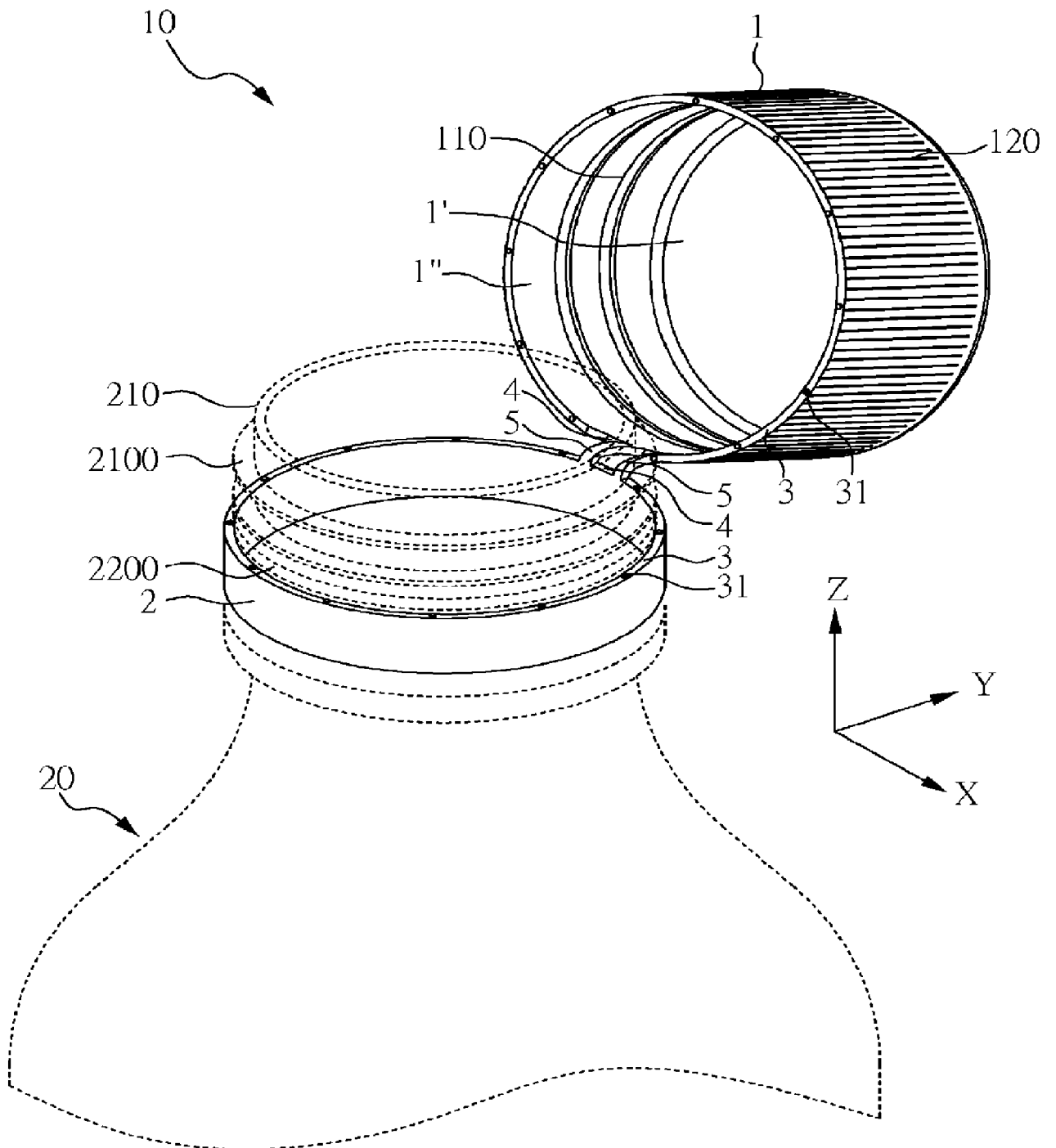

FIG. 3

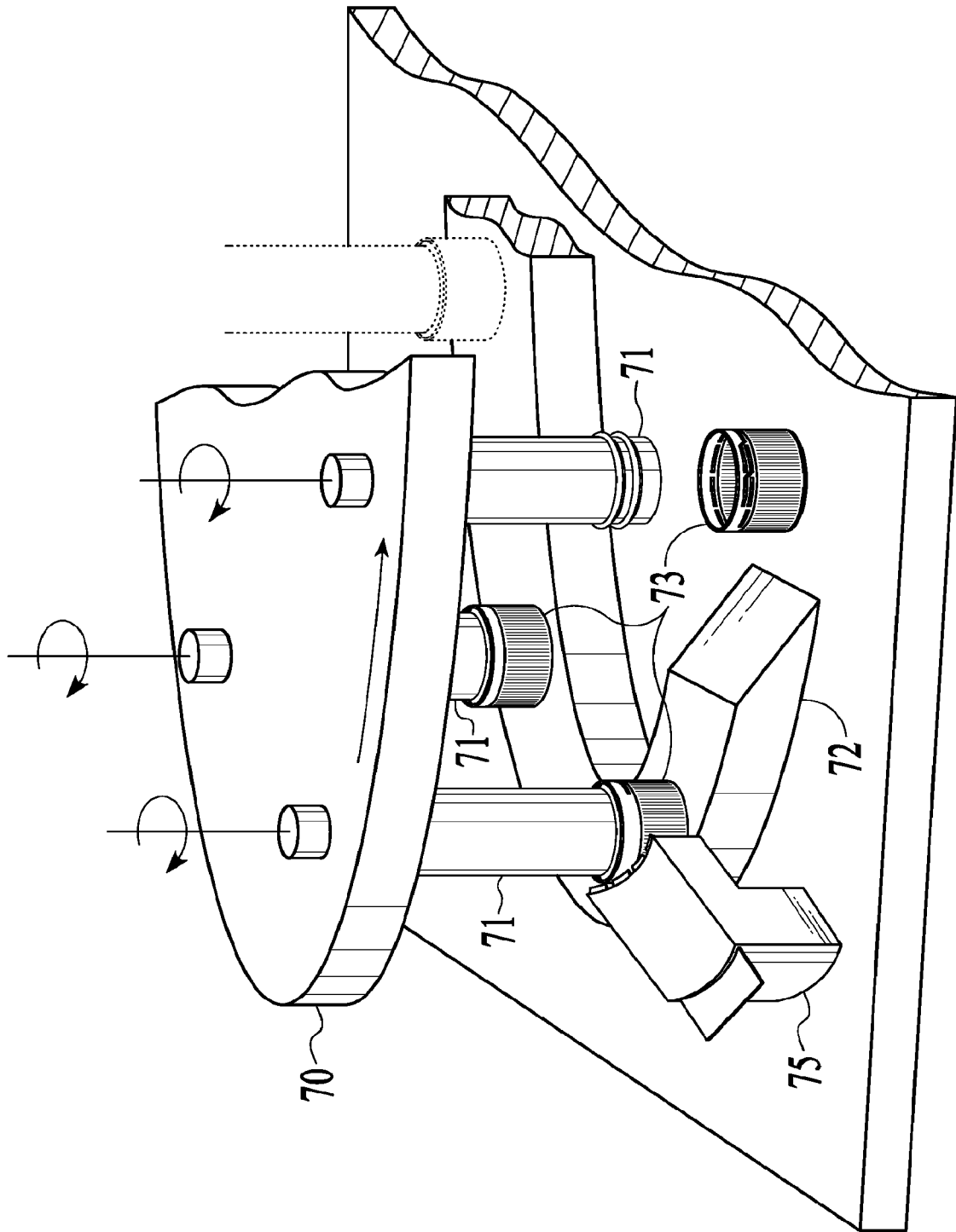

FIG. 4

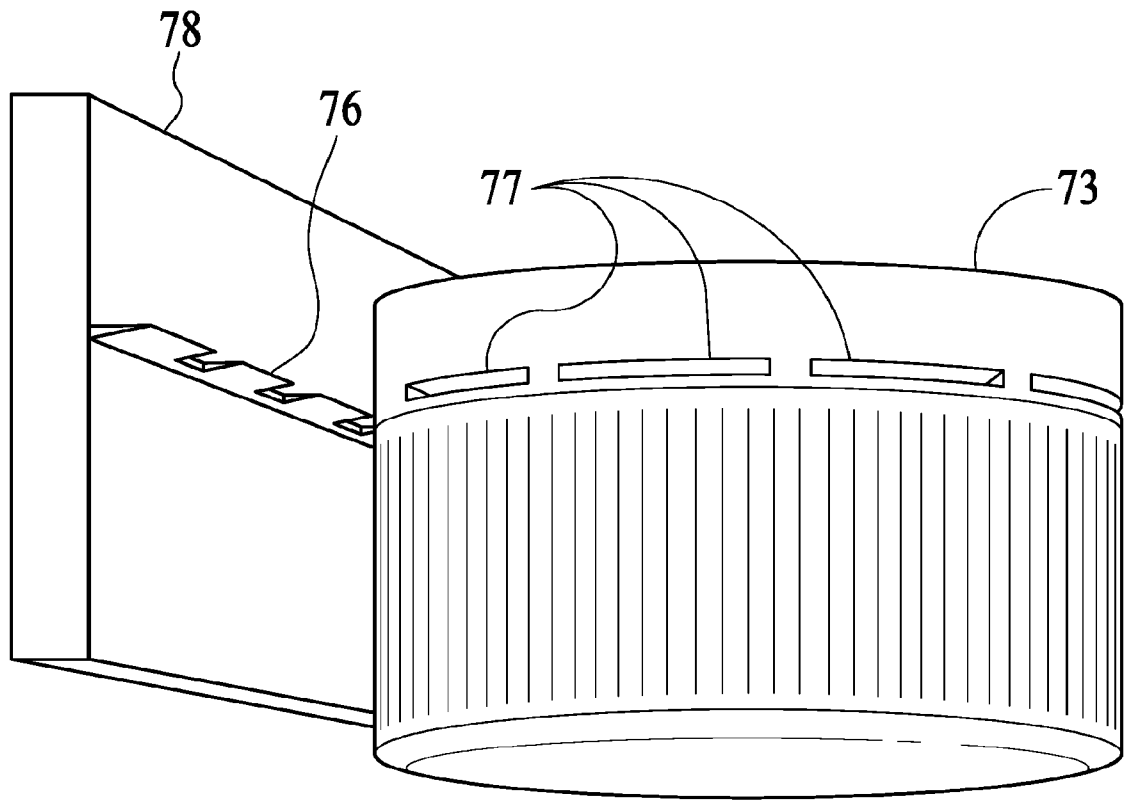

FIG. 5

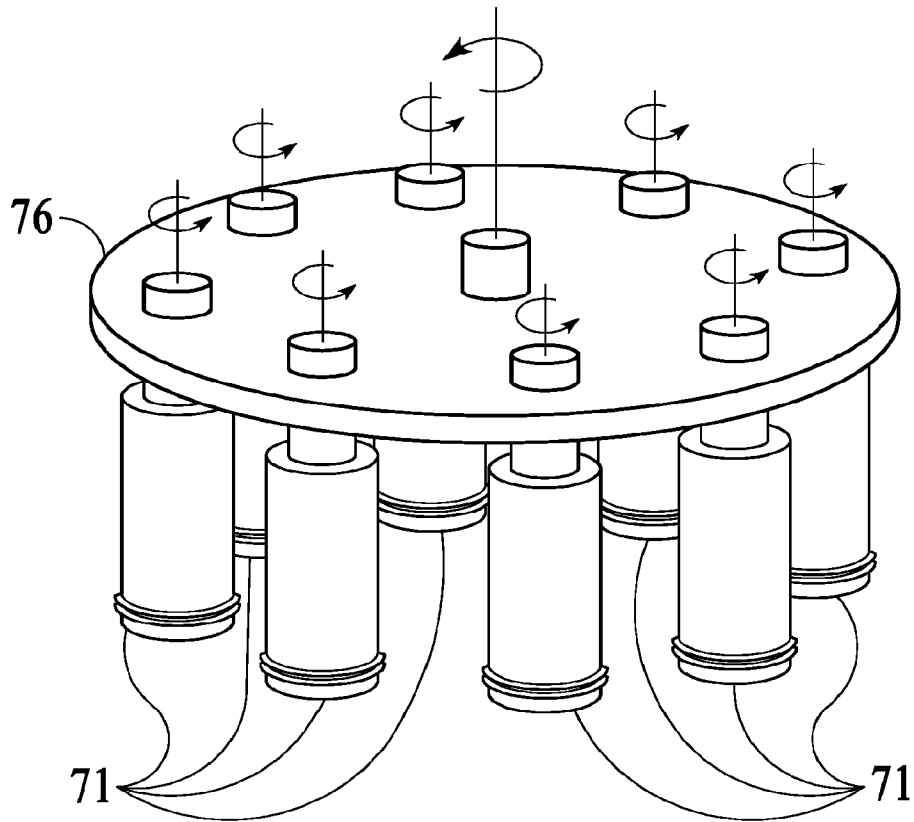

FIG. 6

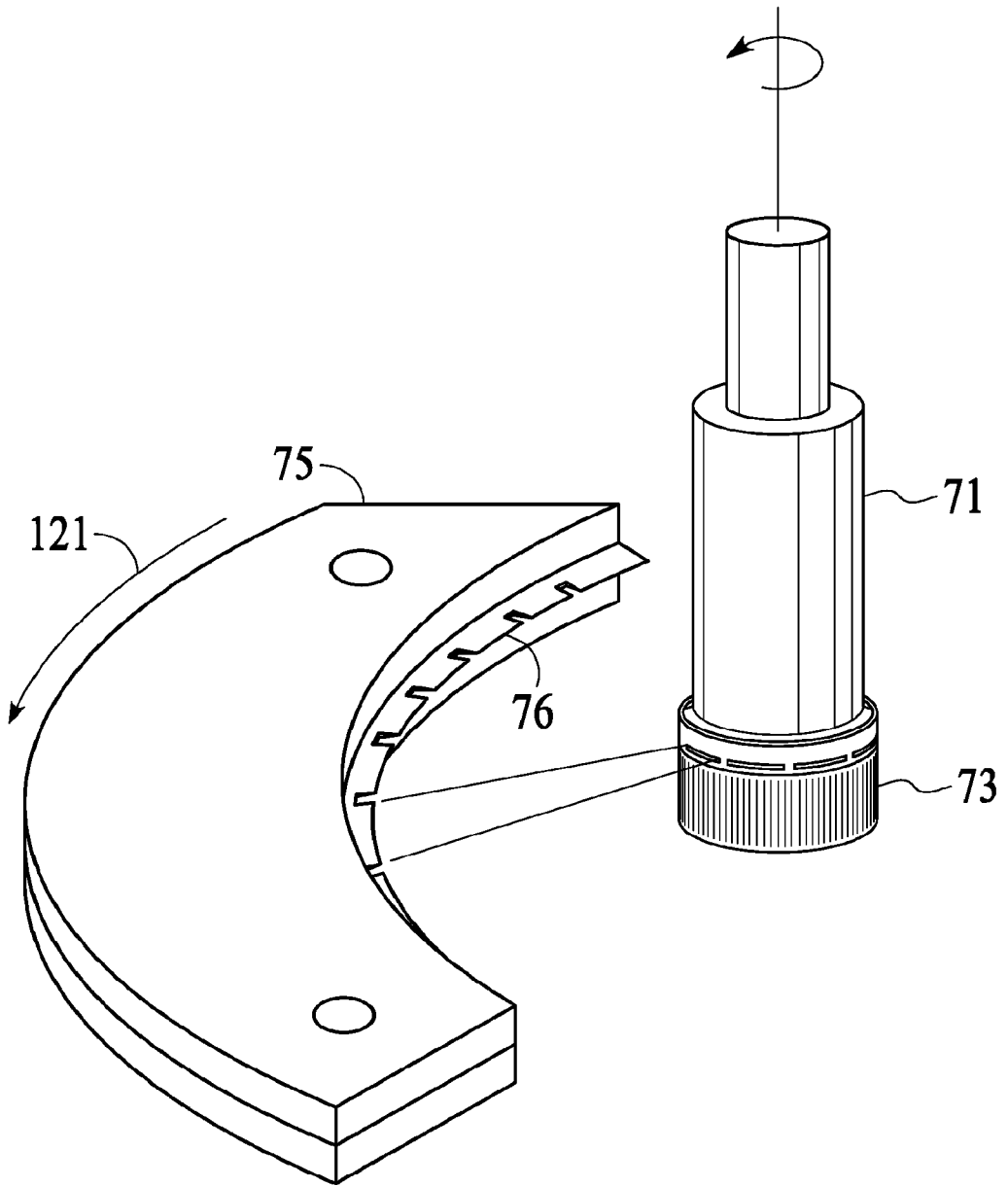

FIG. 7

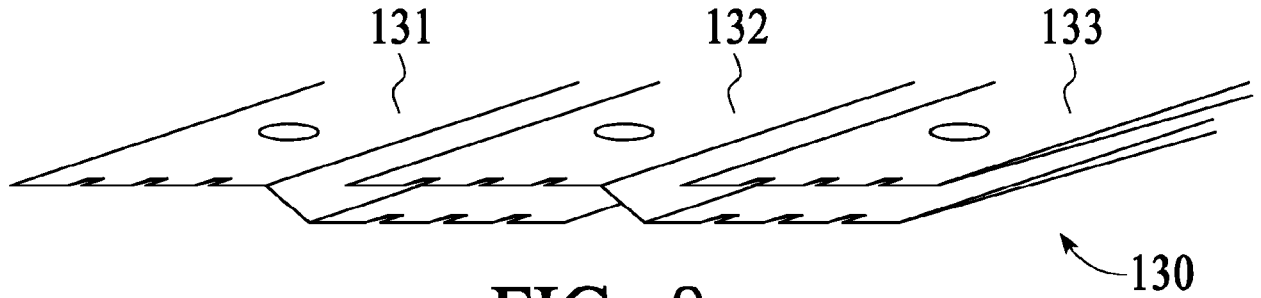

FIG. 8

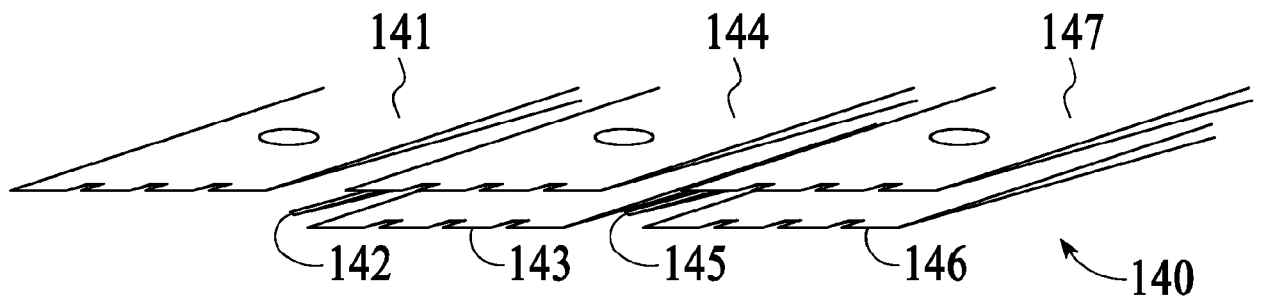

FIG. 9

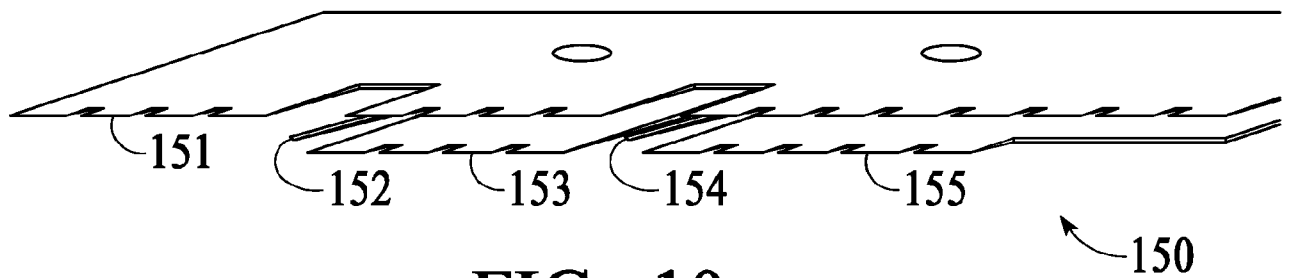

FIG. 10

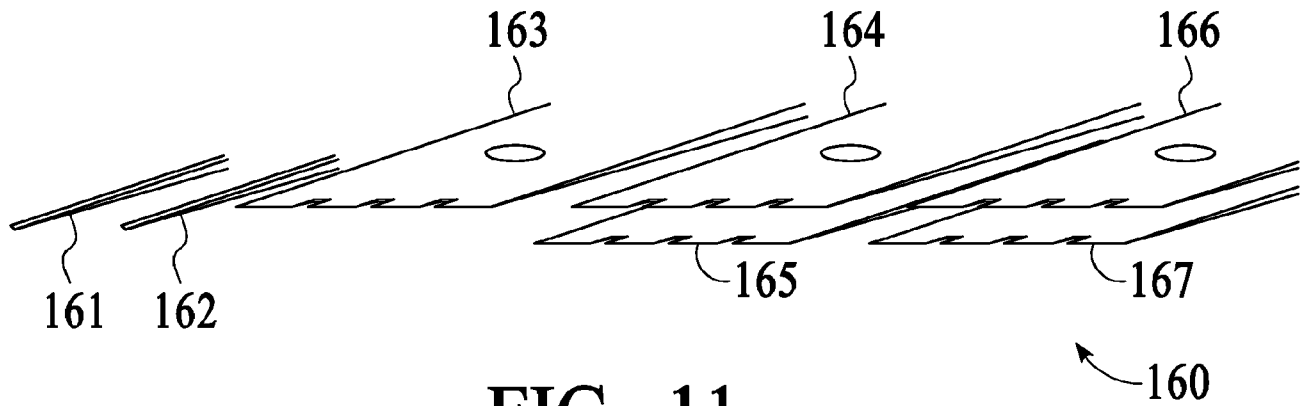

FIG. 11

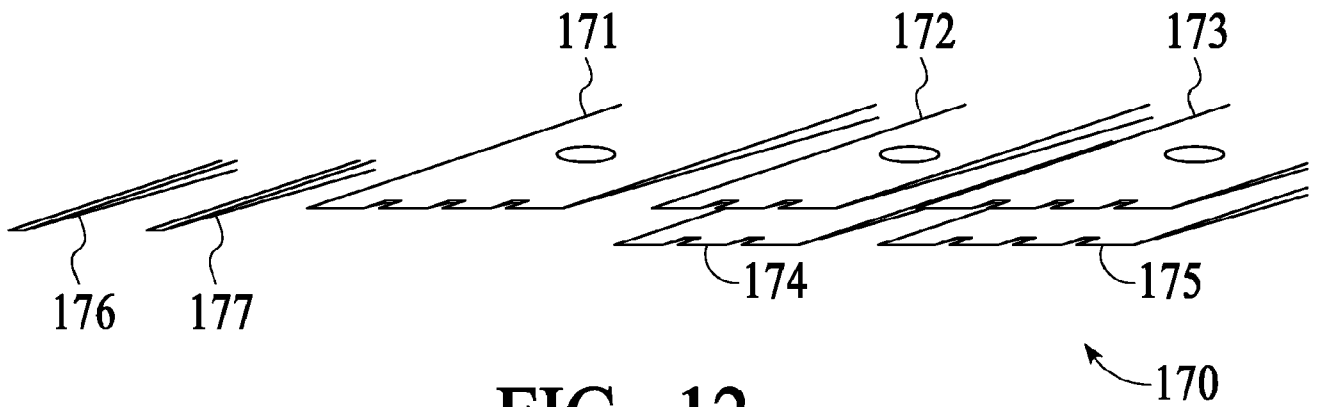

FIG. 12

13/38

FIG. 13

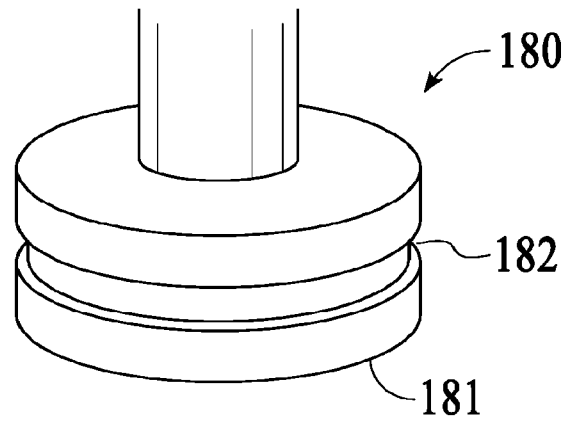

FIG. 14

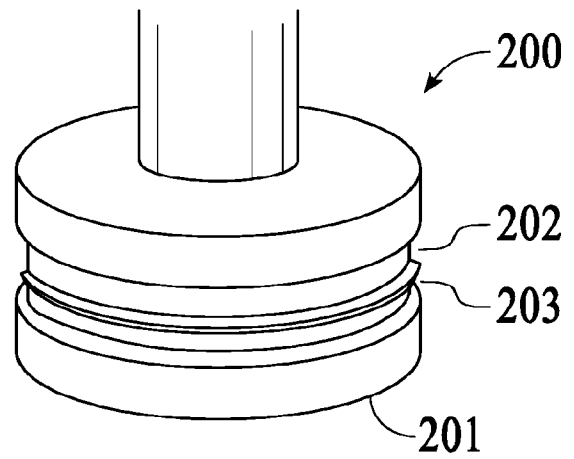
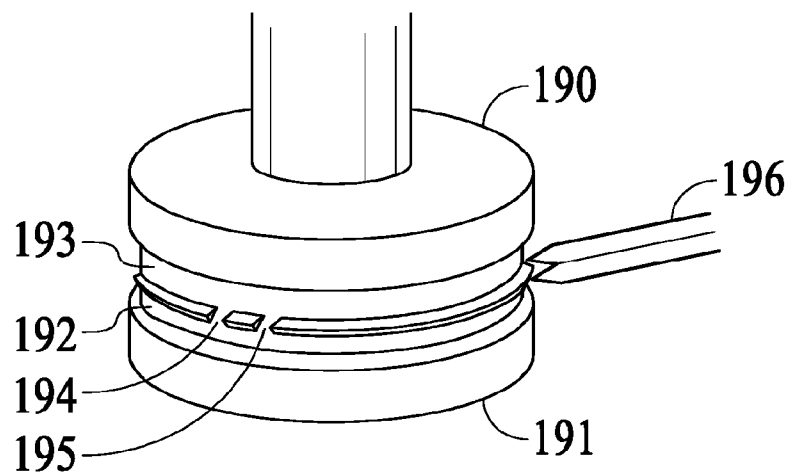

FIG. 15



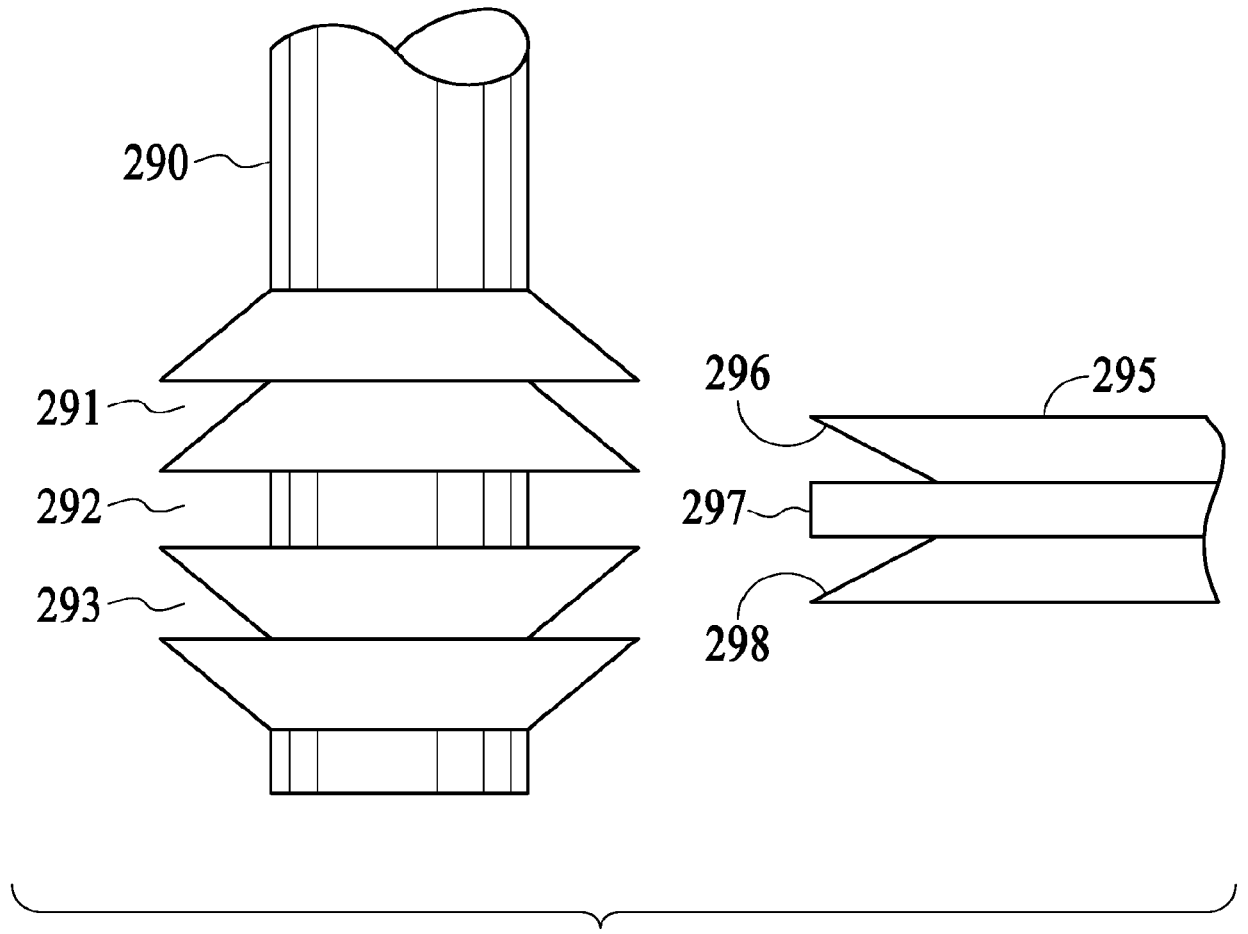

FIG. 16

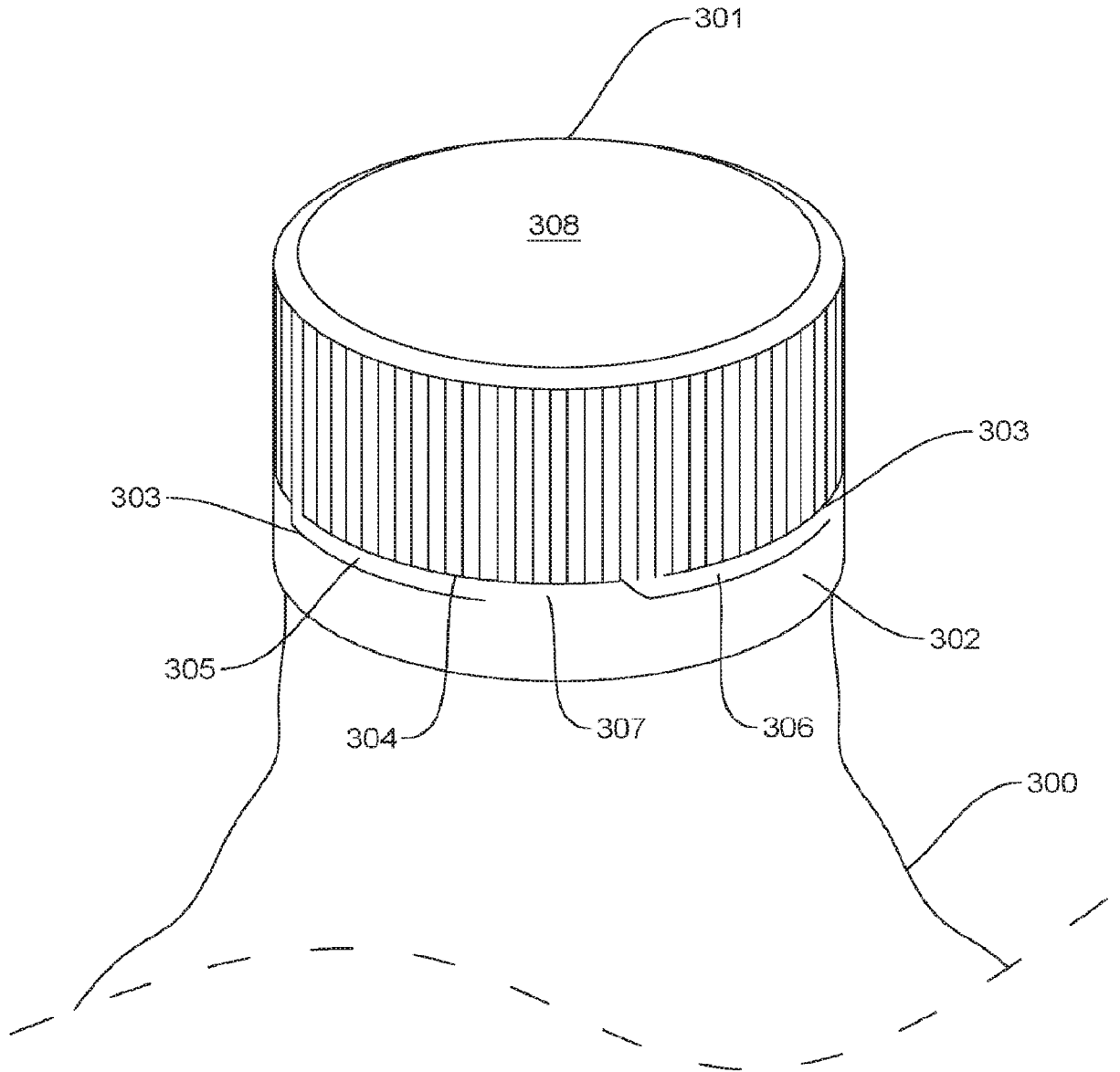

FIG. 17

16/38

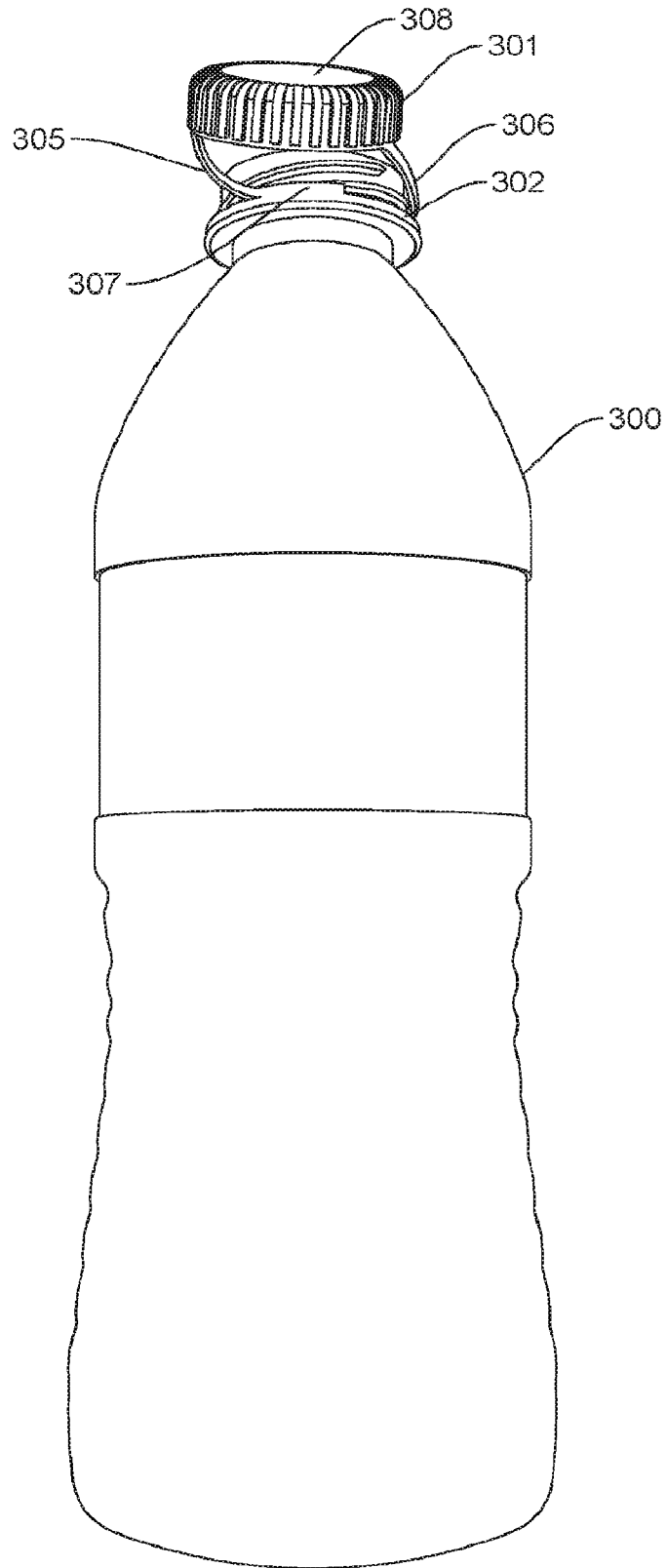

FIG. 18

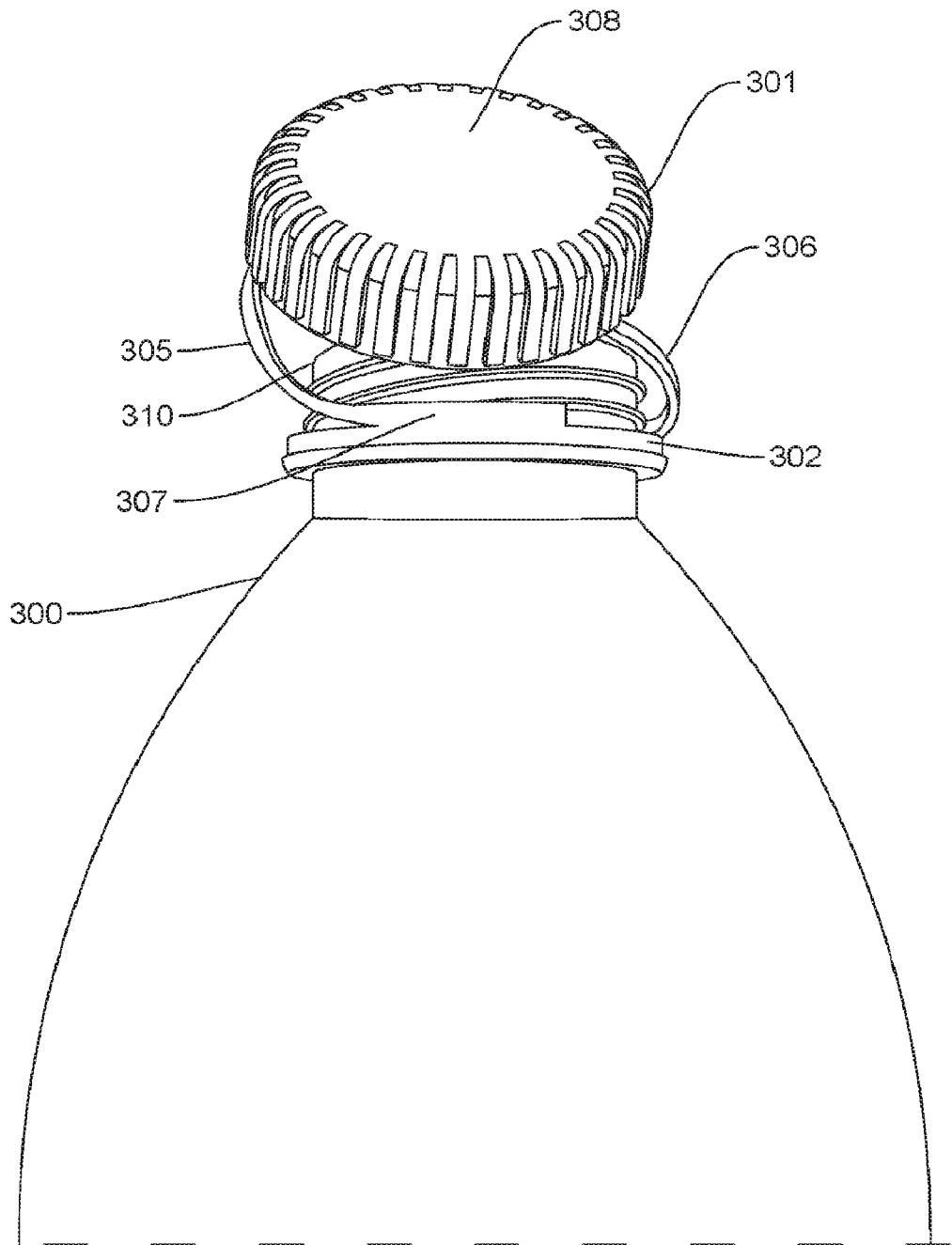

FIG. 19

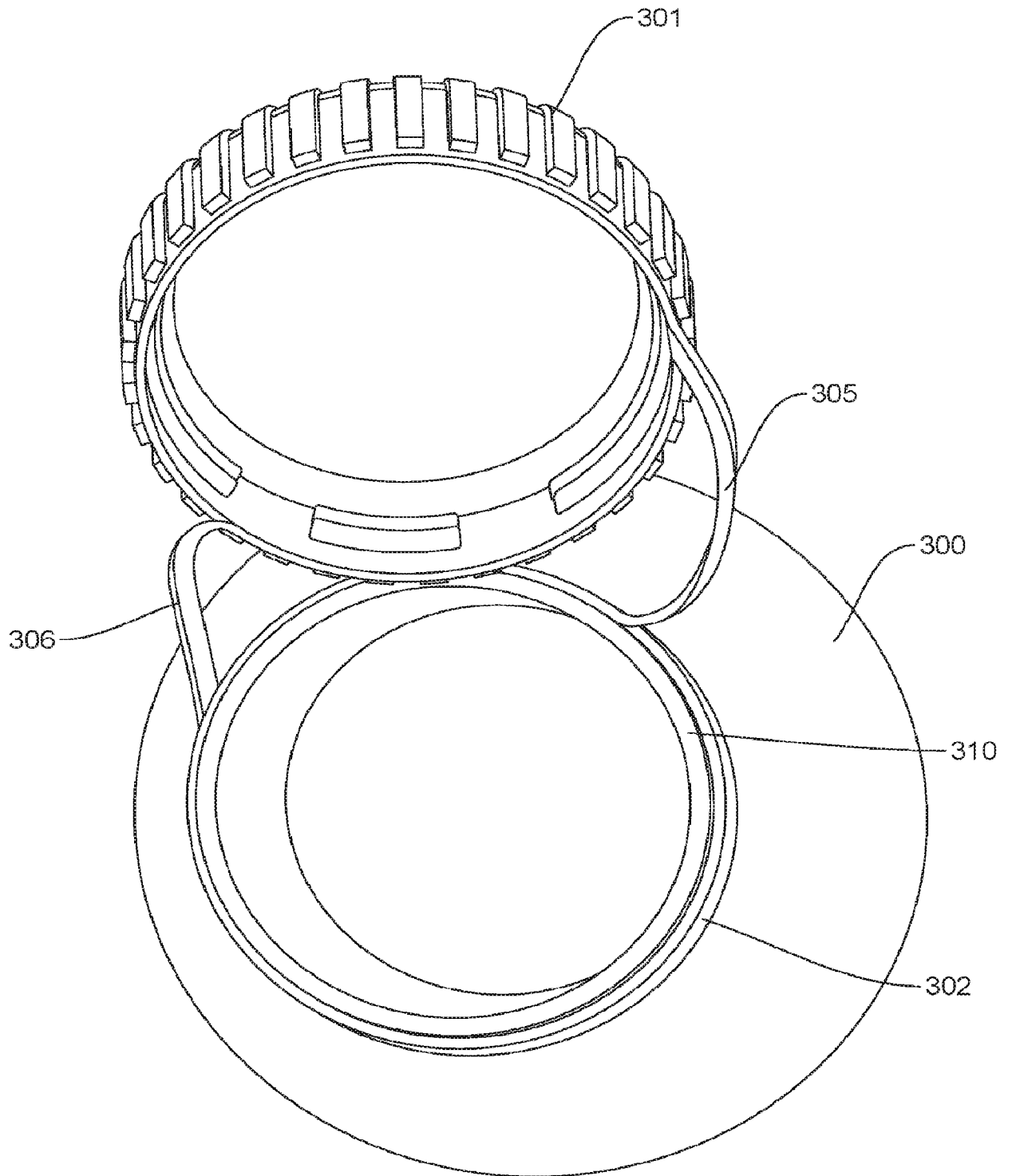

FIG. 20

19/38

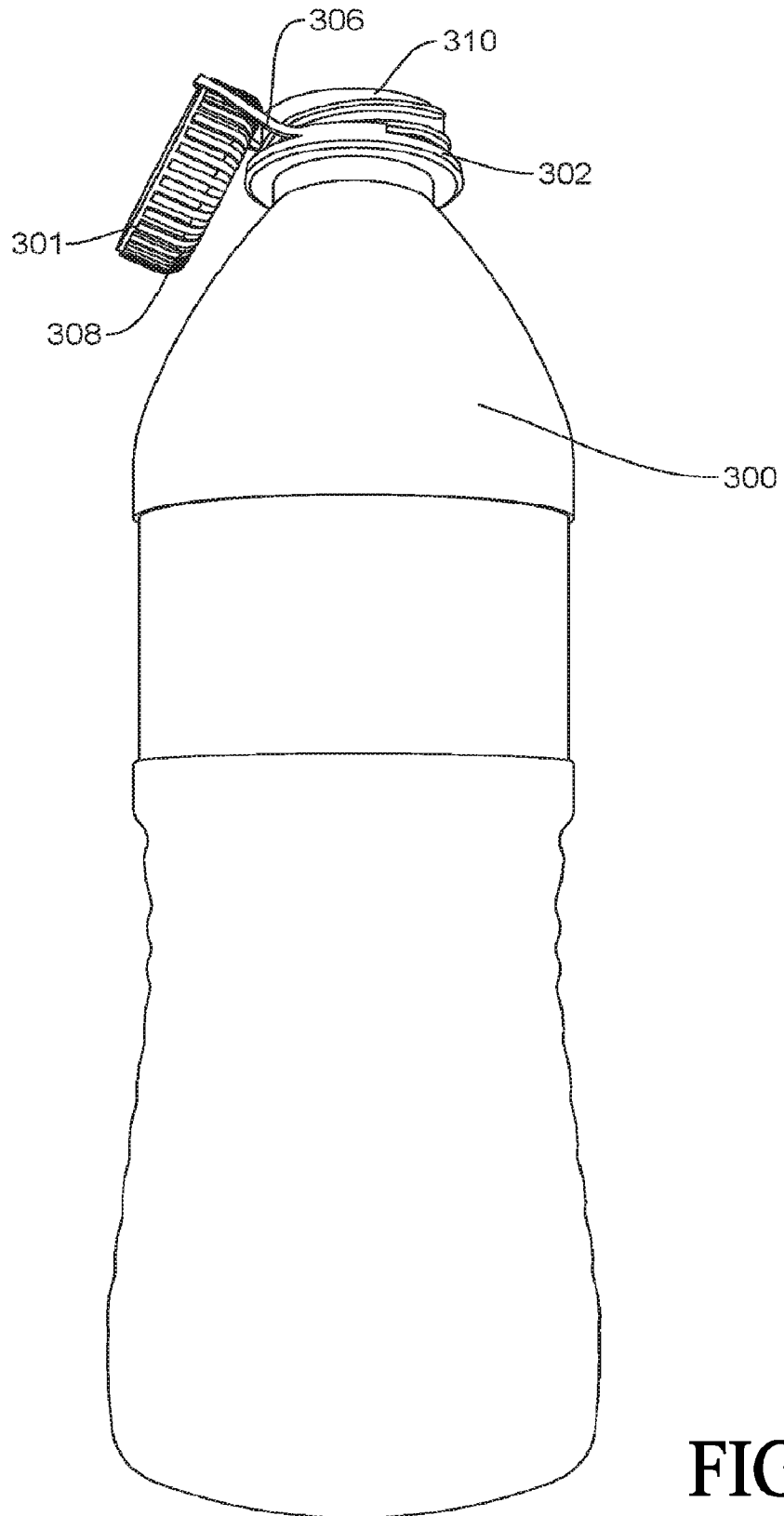

FIG. 21

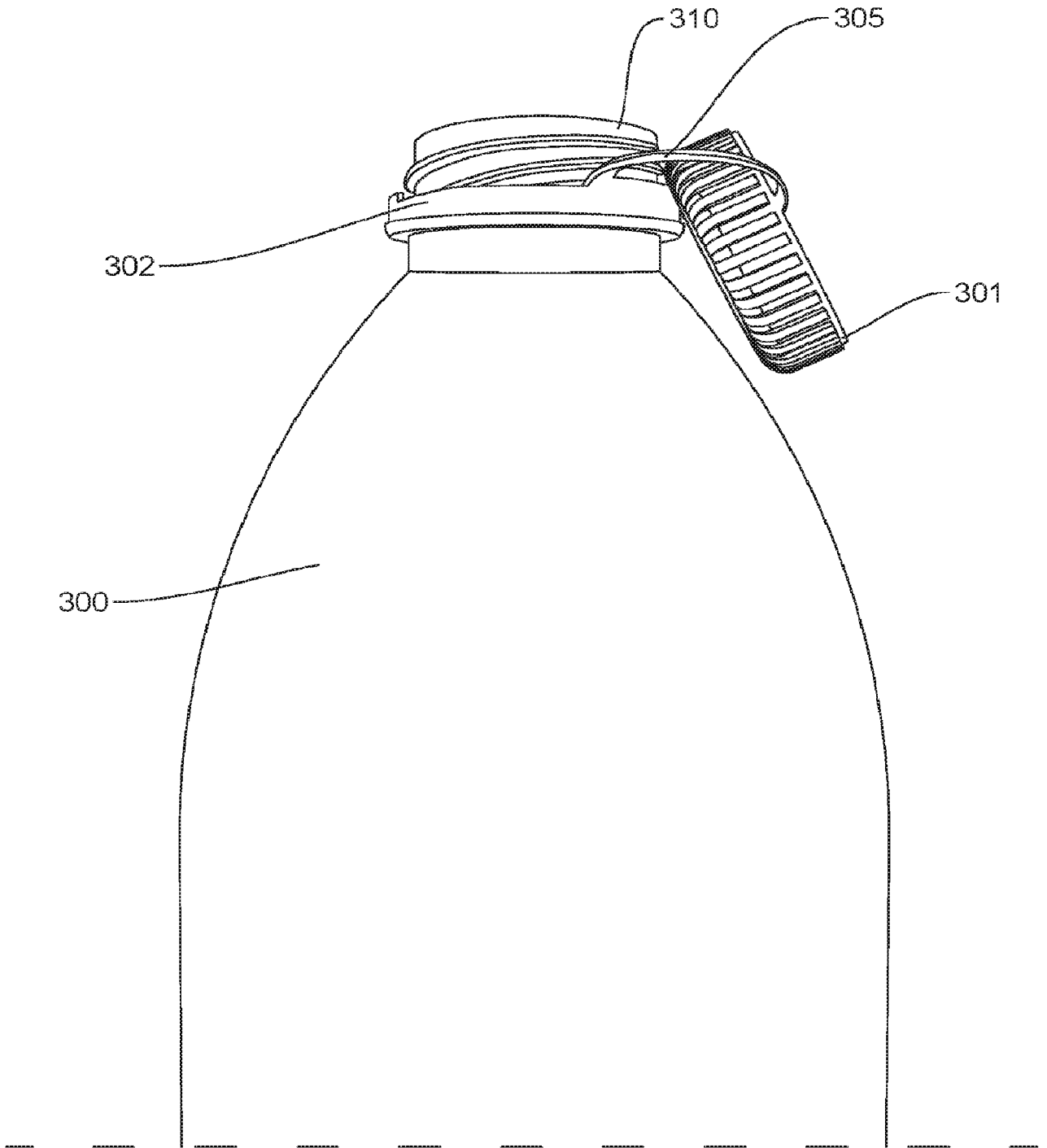

FIG. 22

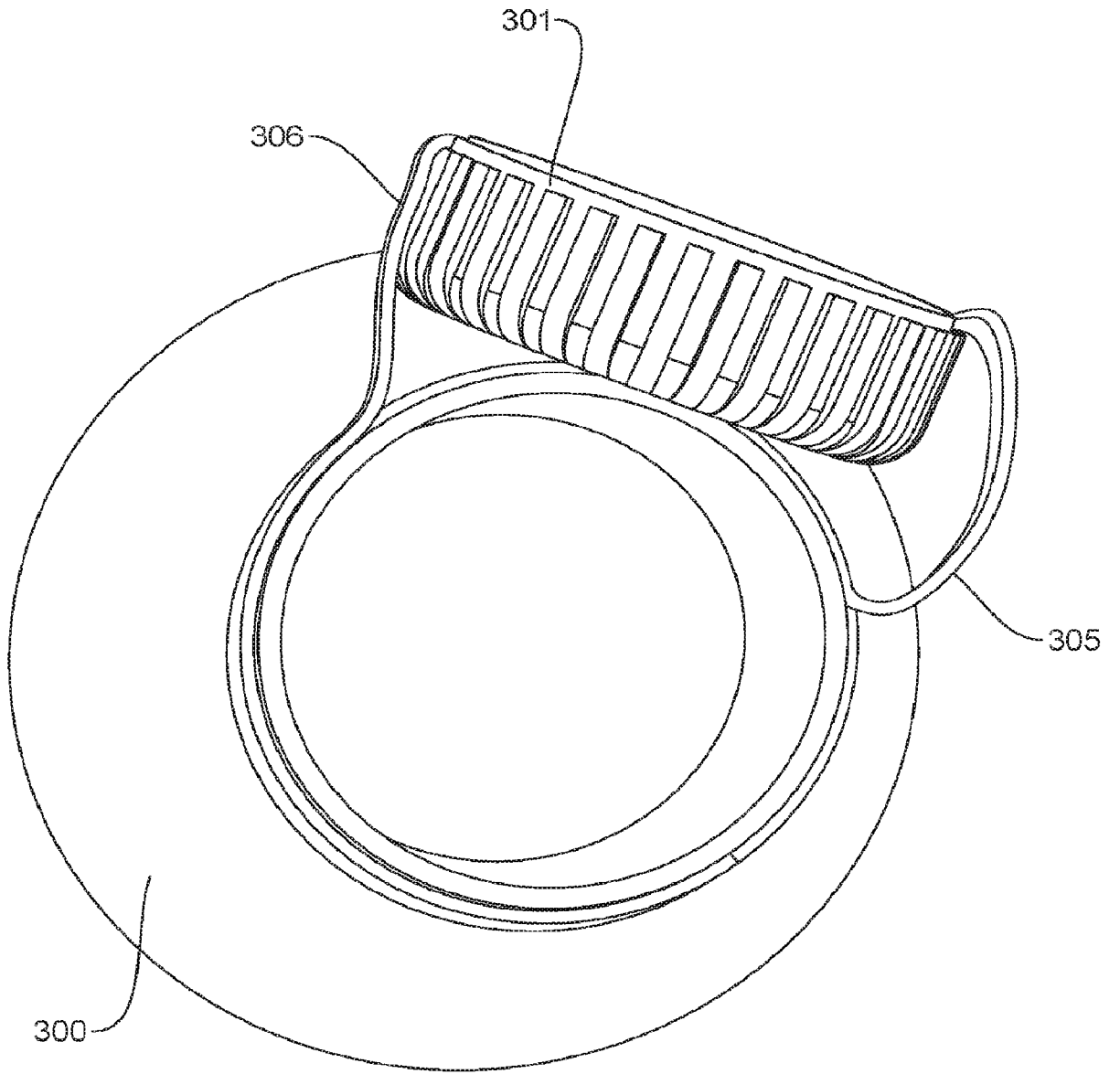

FIG. 23

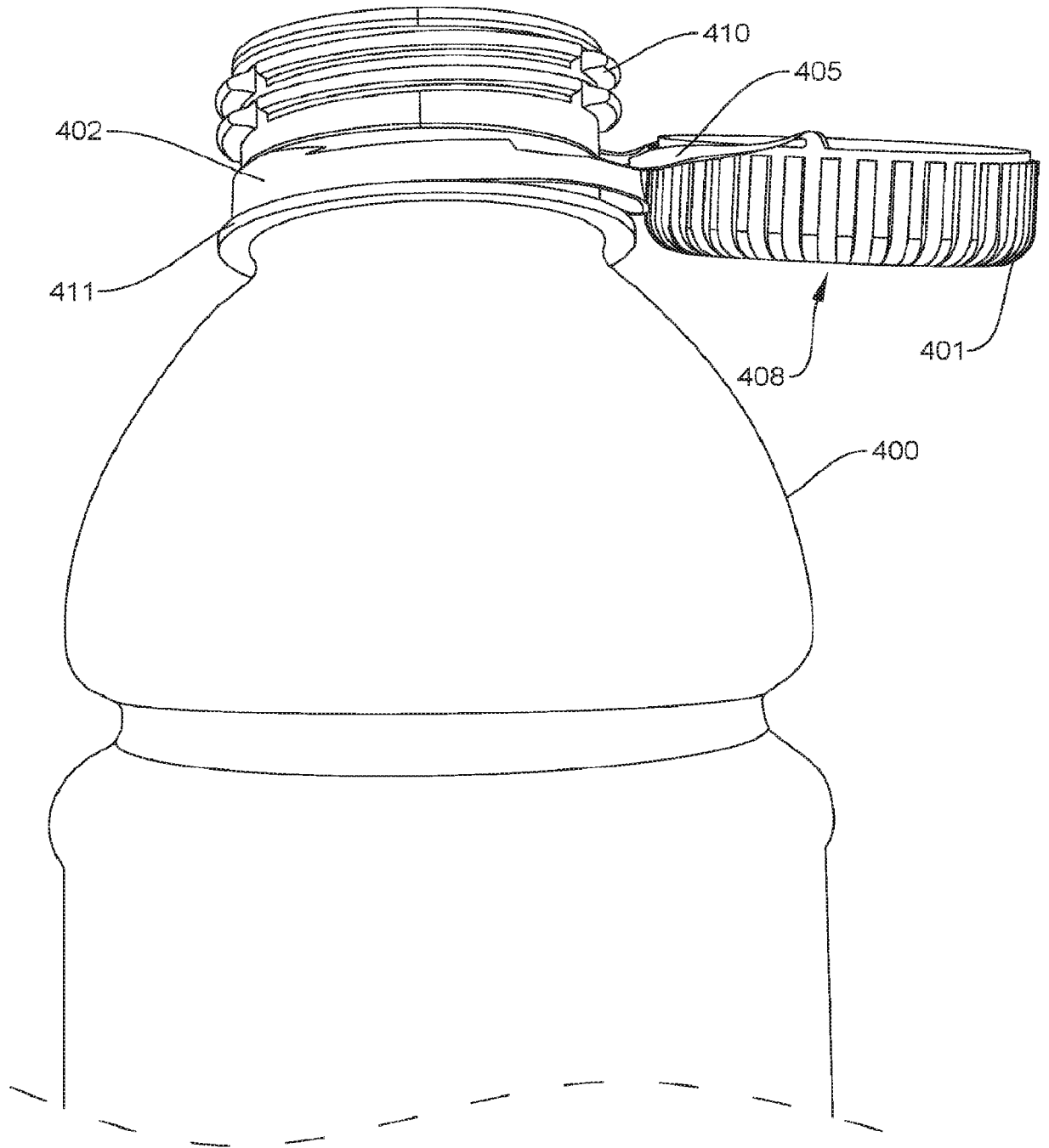

FIG. 24

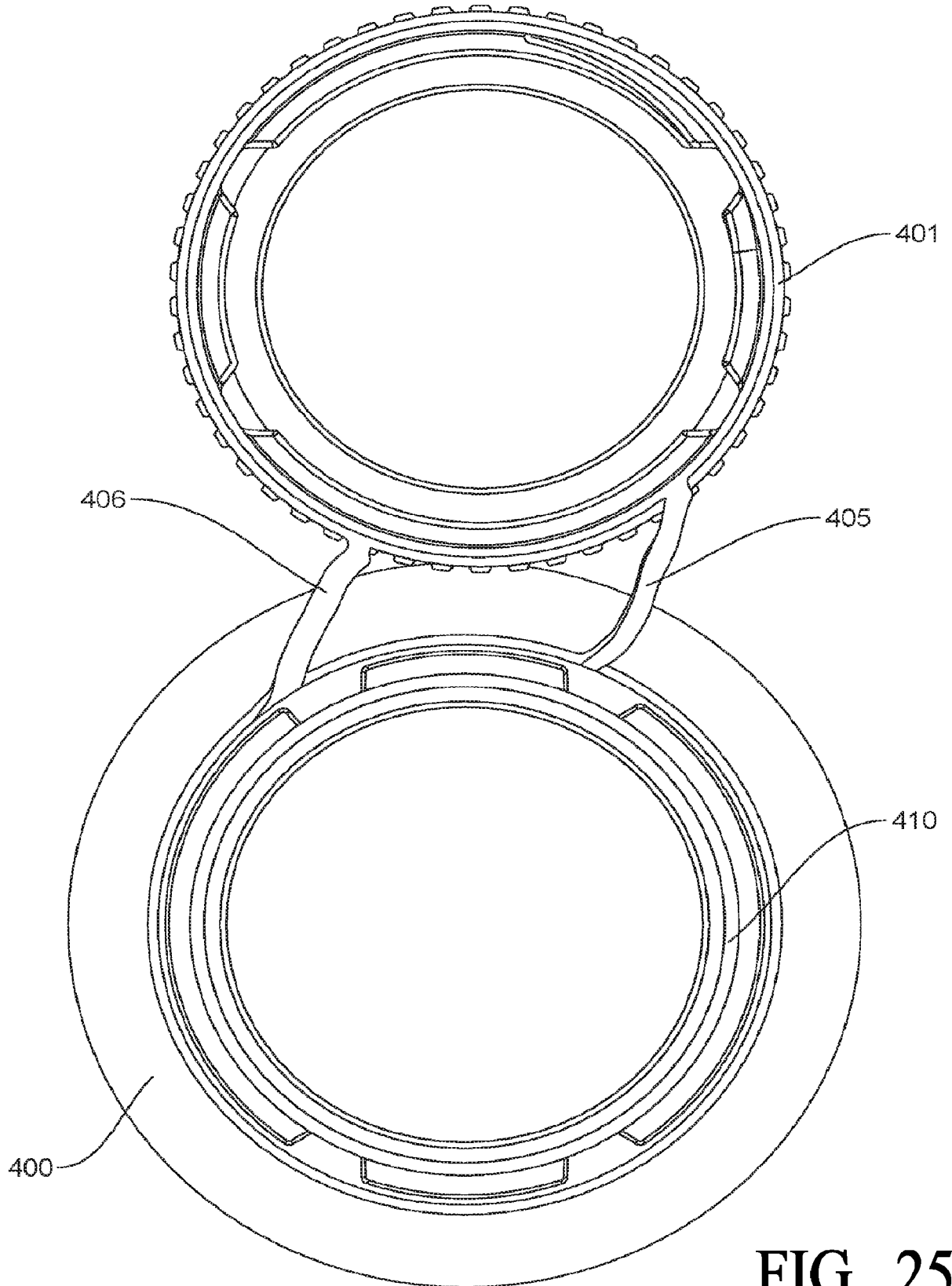

FIG. 25

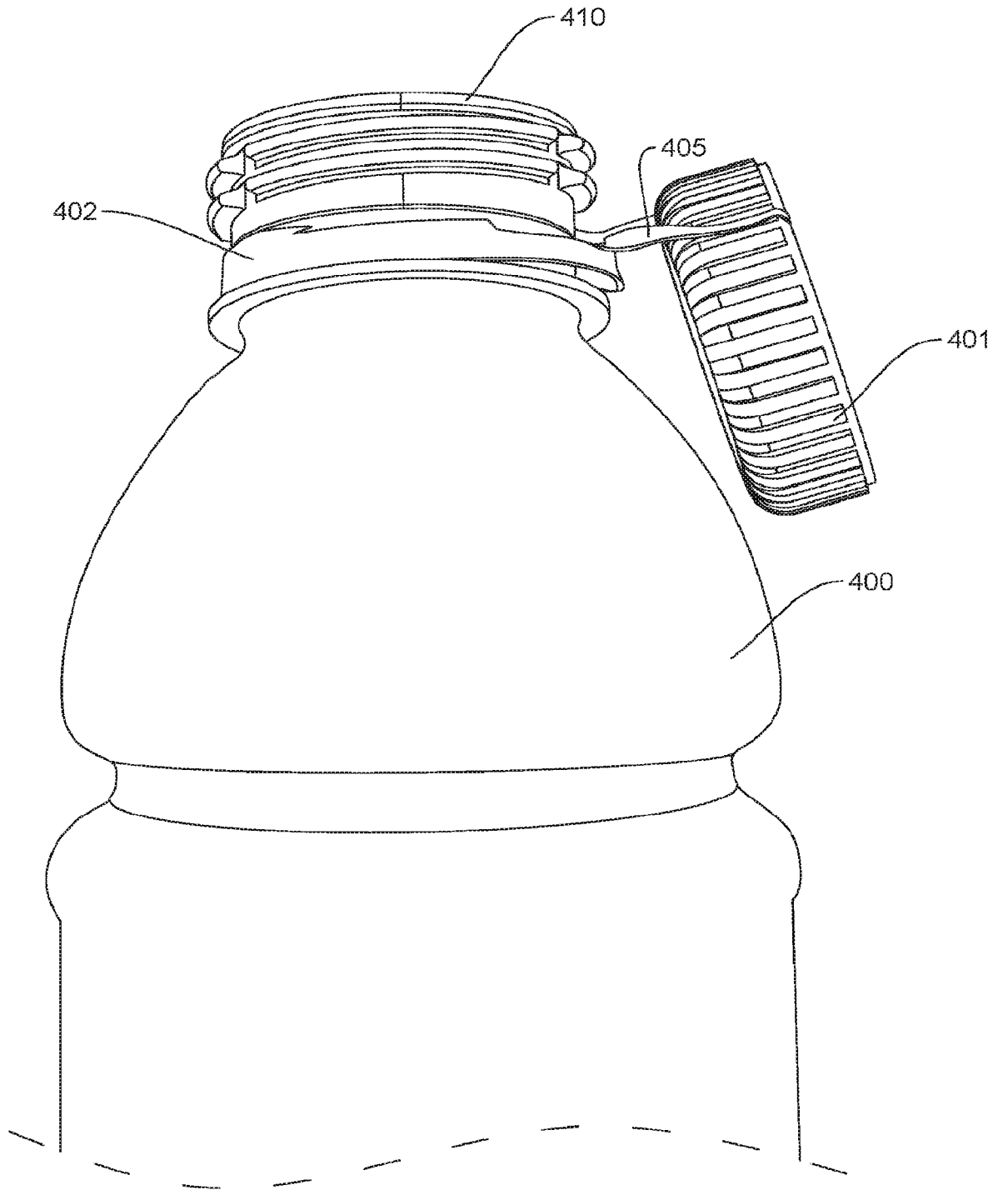

FIG. 26

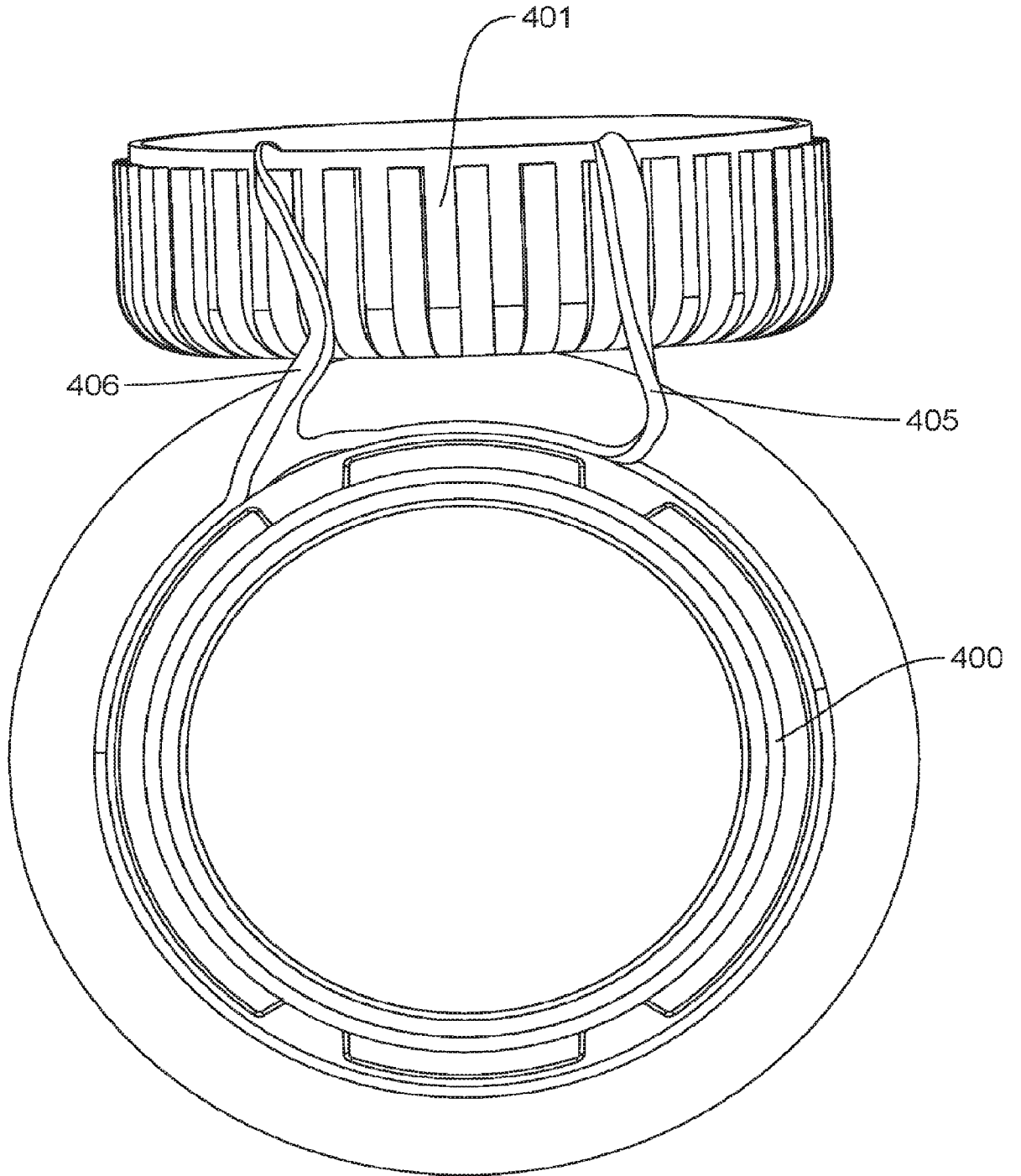

FIG. 27

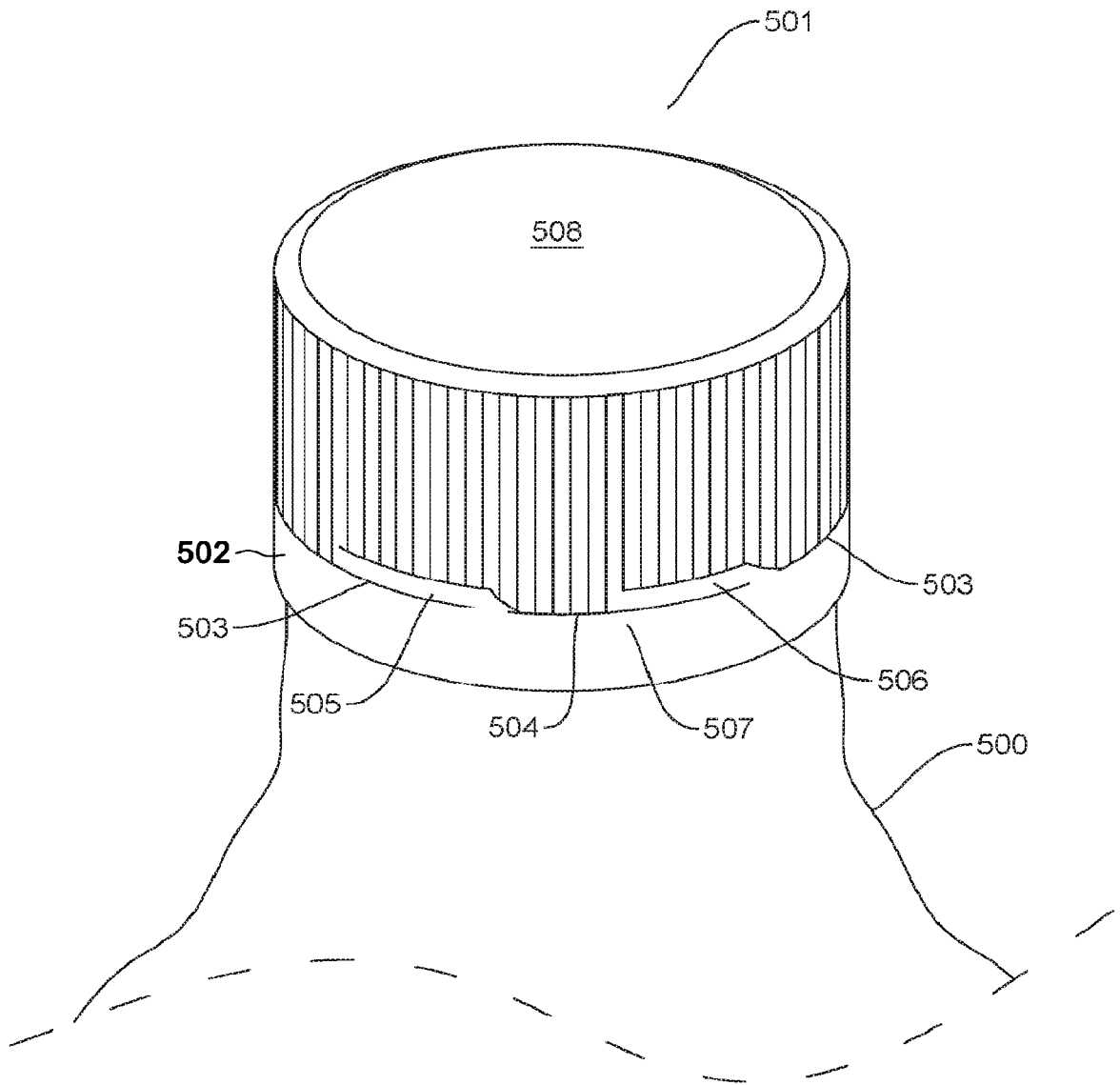

FIG. 28

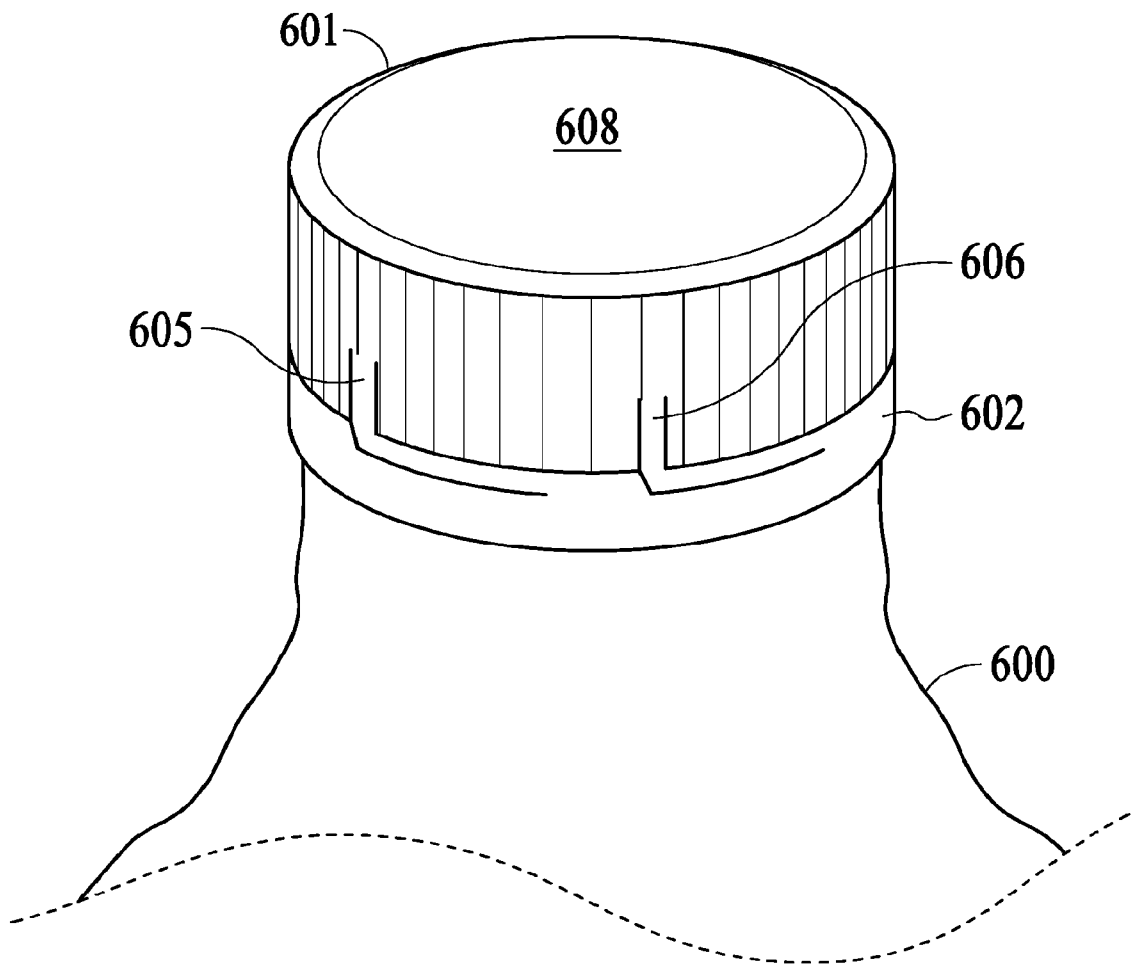

FIG. 29

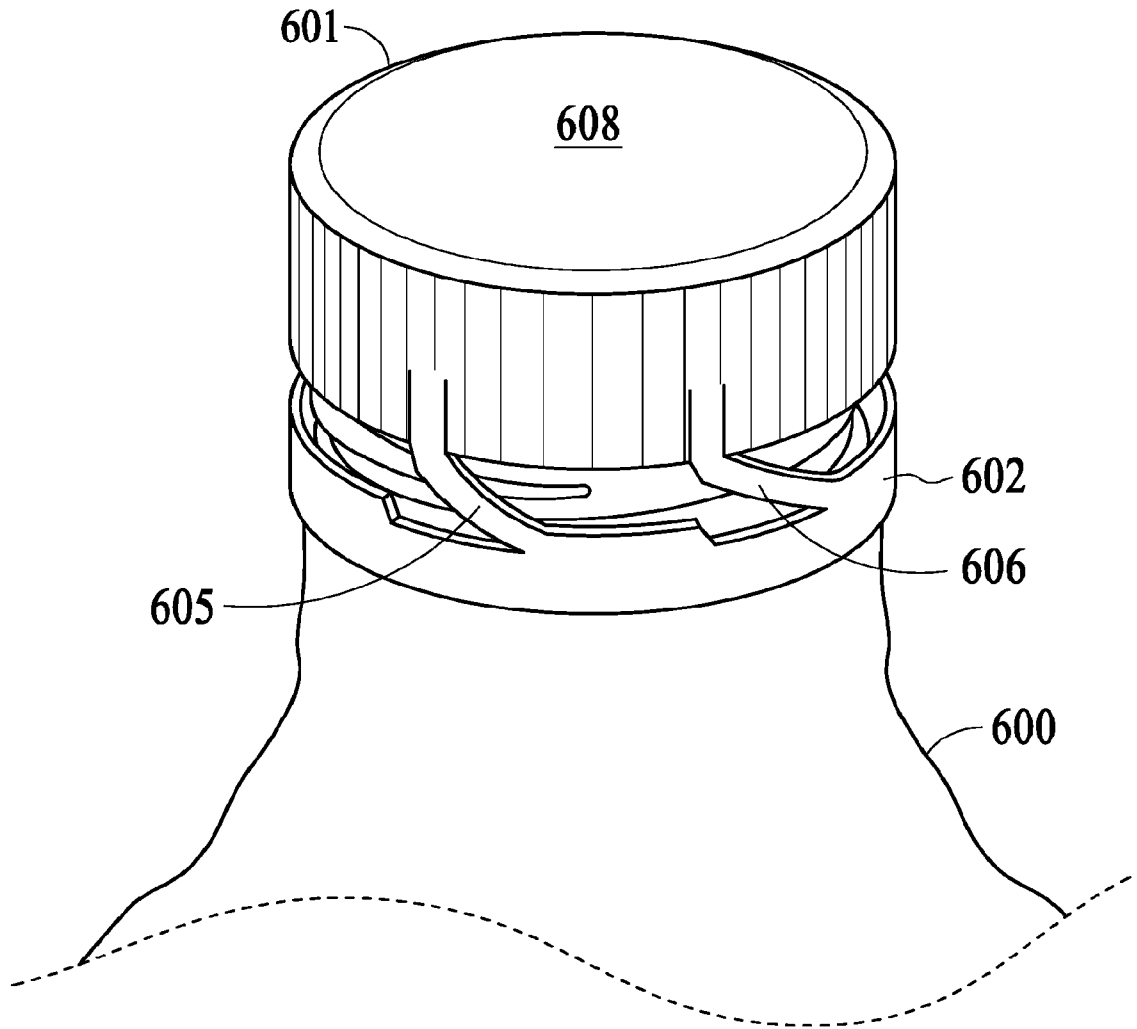

FIG. 30

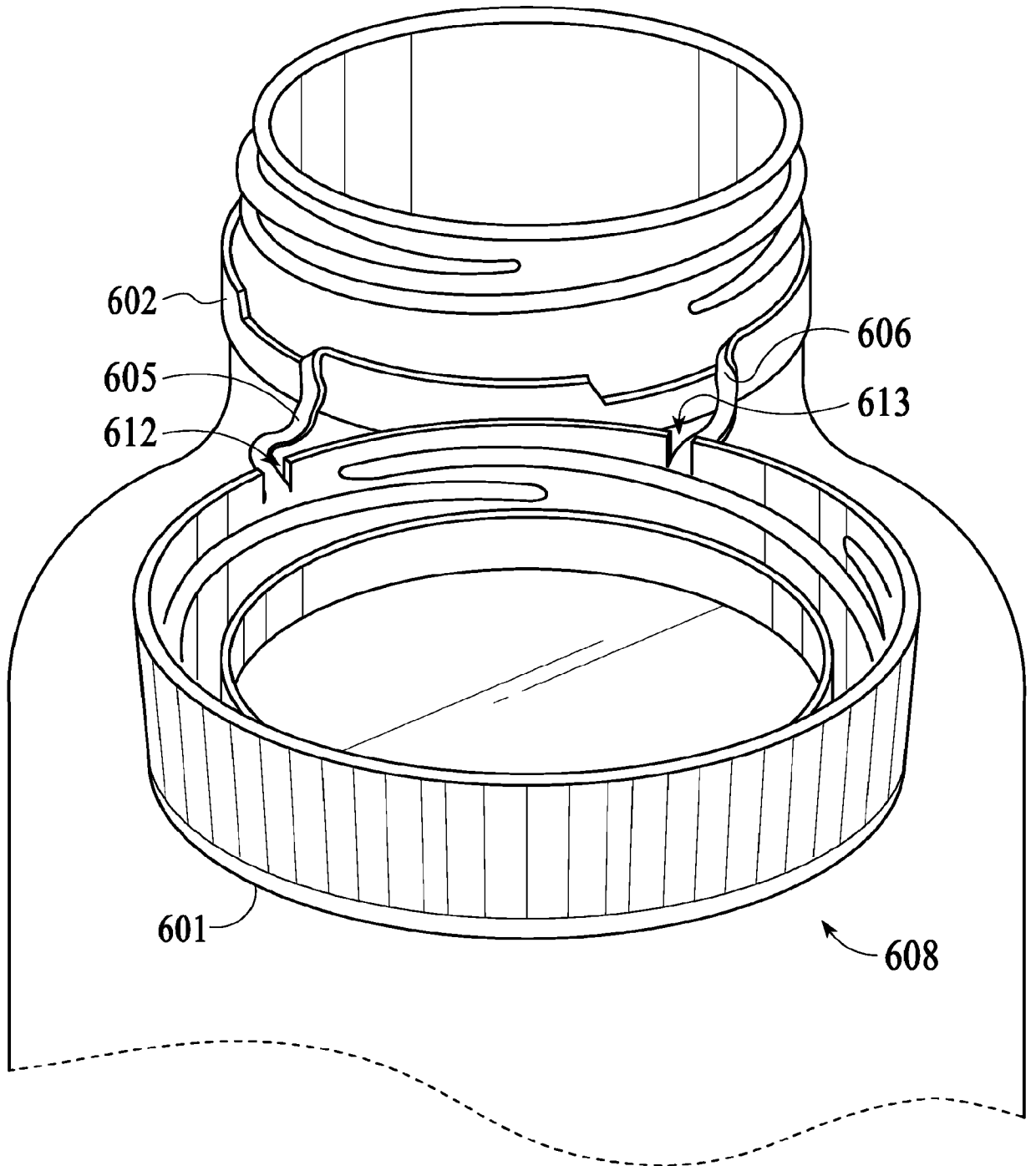

FIG. 31

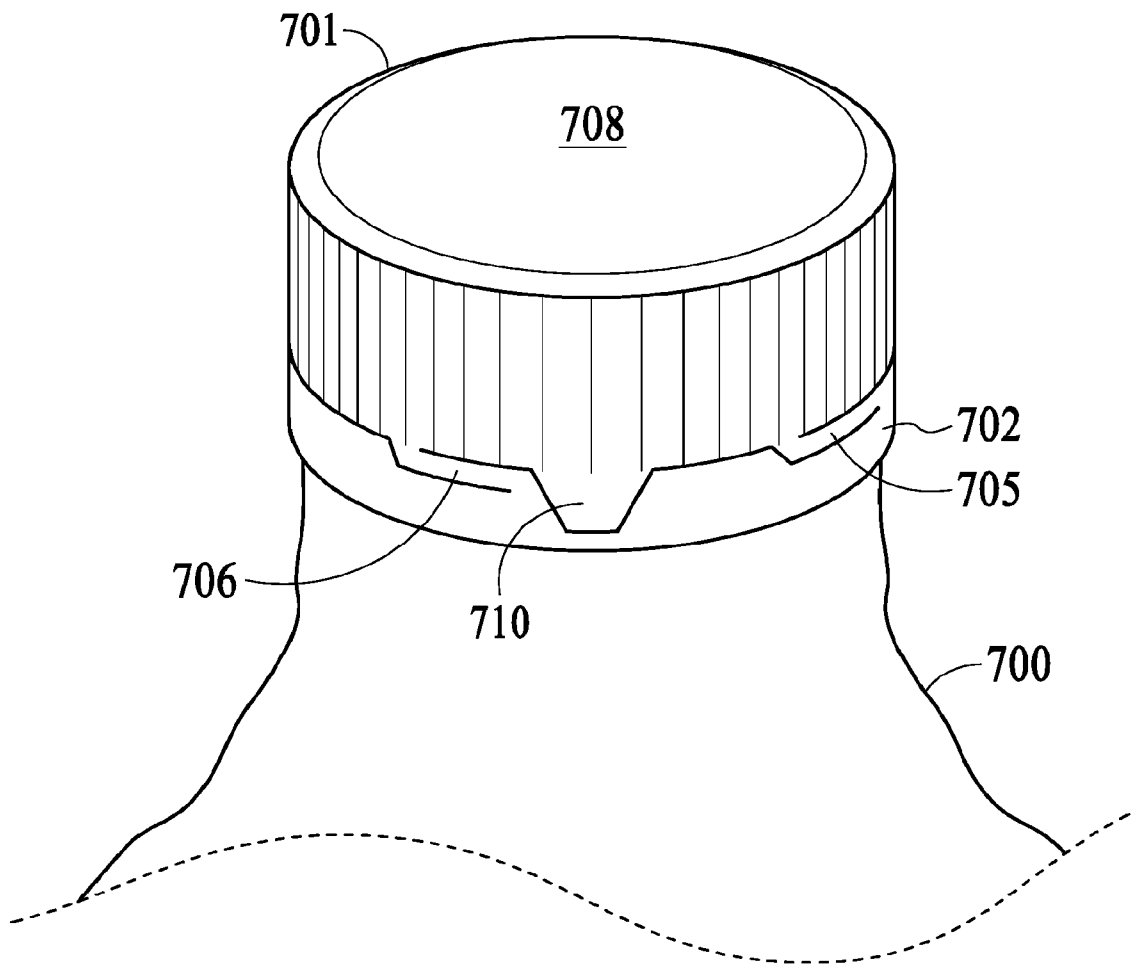

FIG. 32

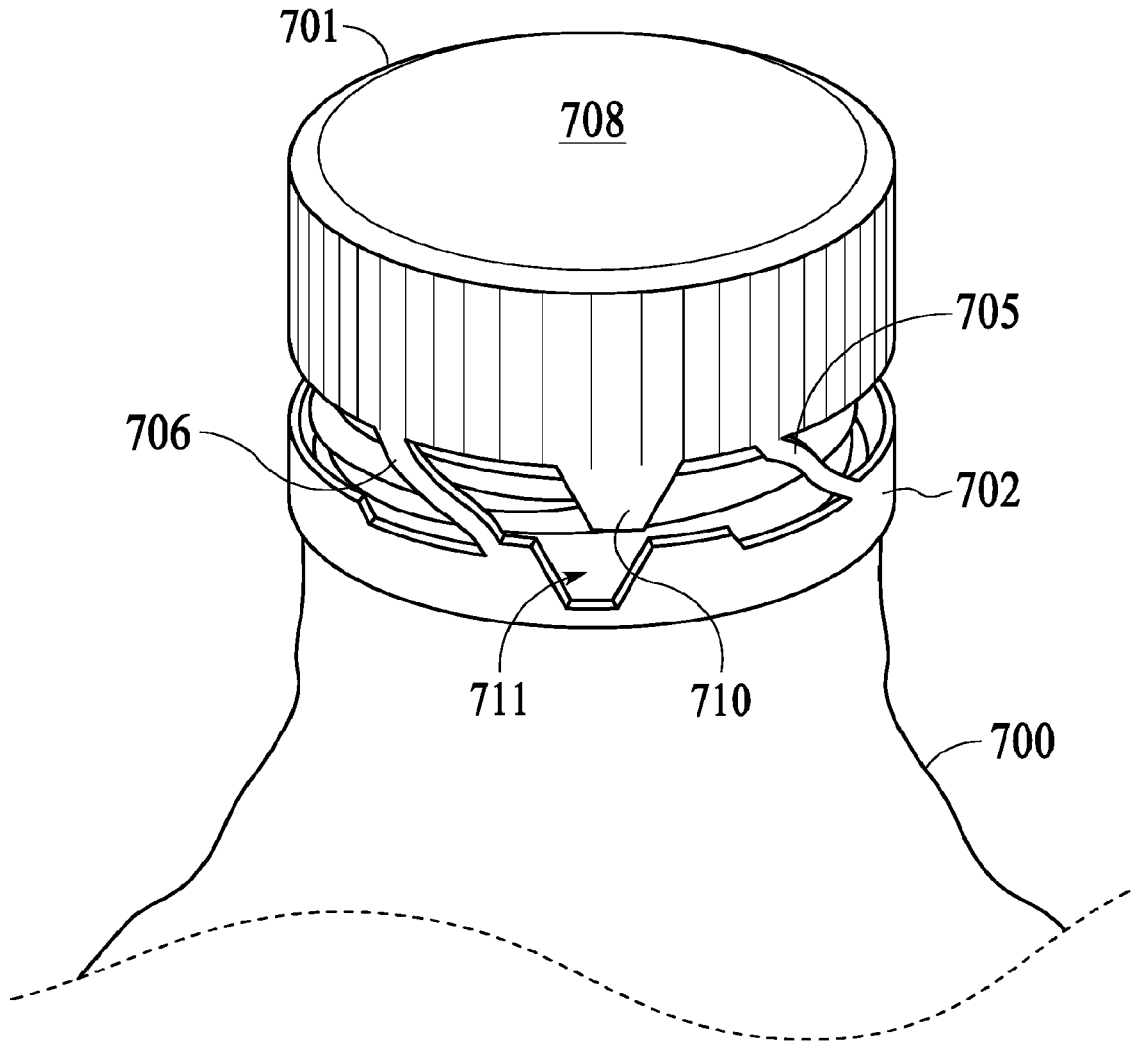

FIG. 33

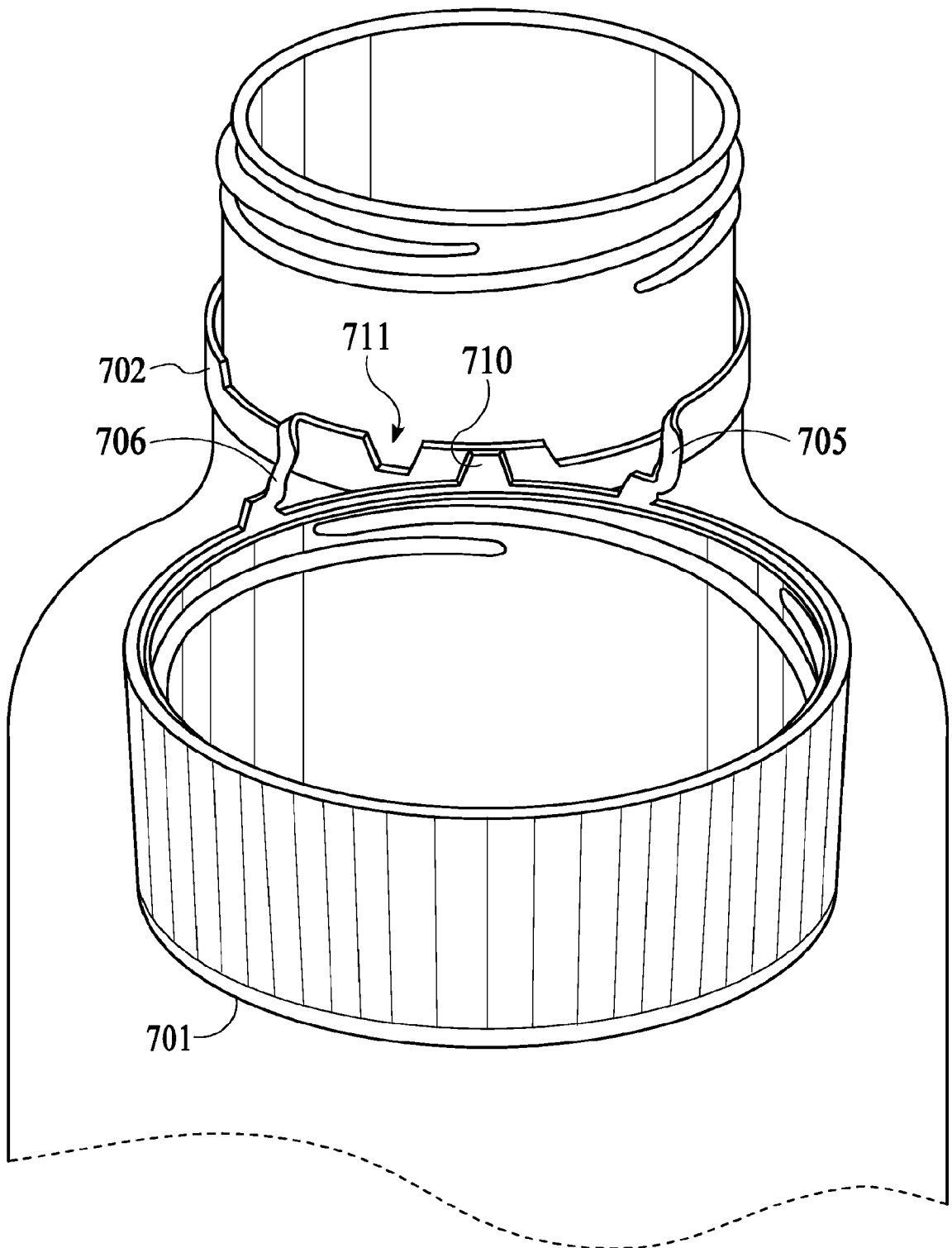

FIG. 34

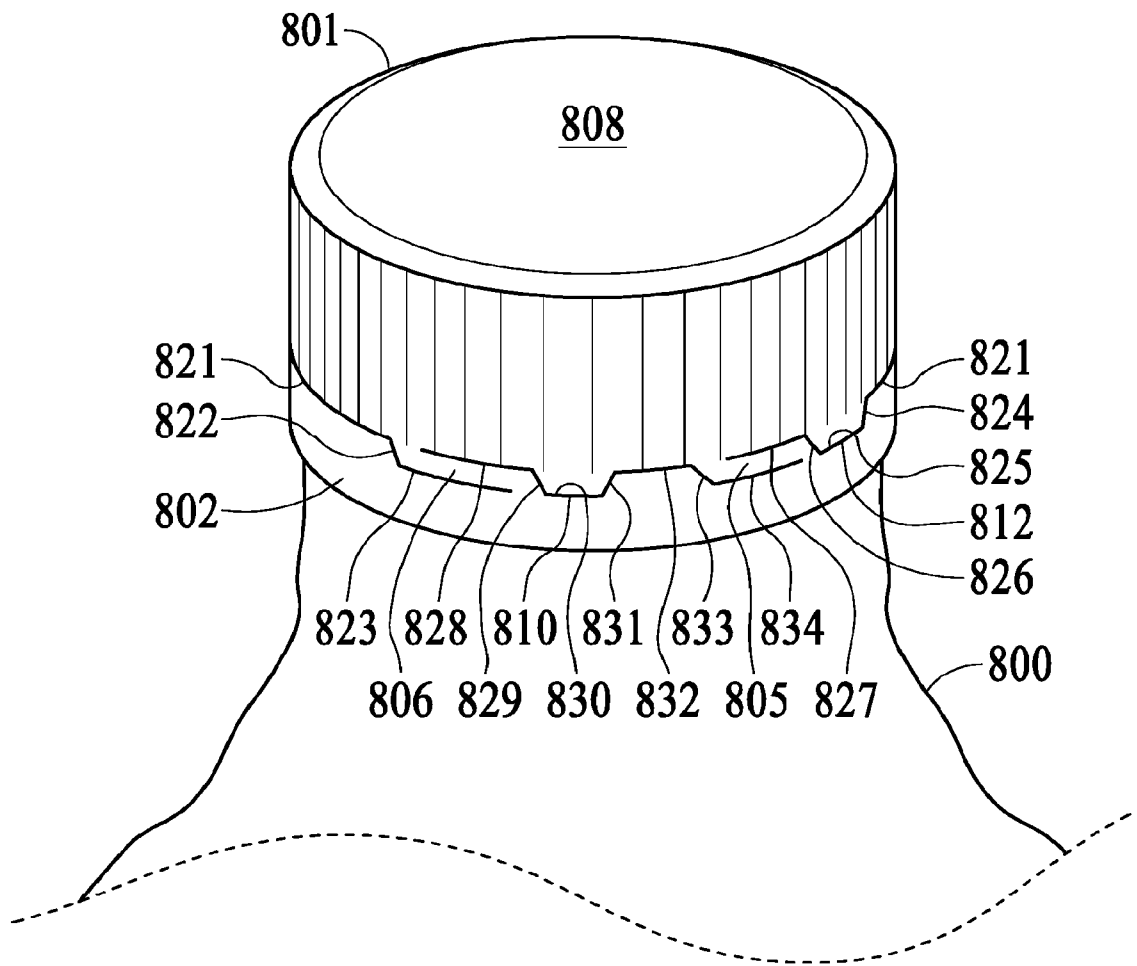

FIG. 35

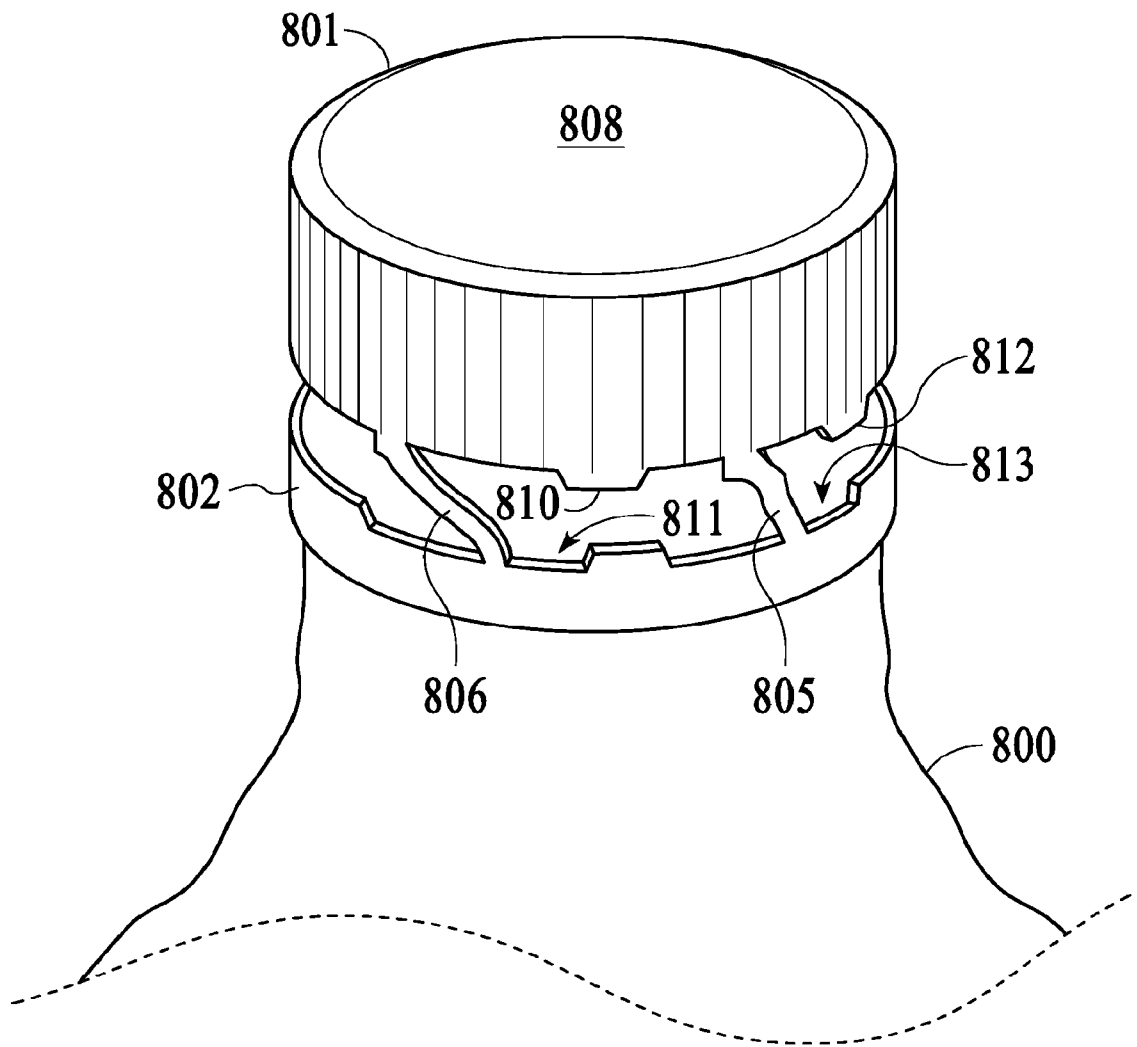

FIG. 36

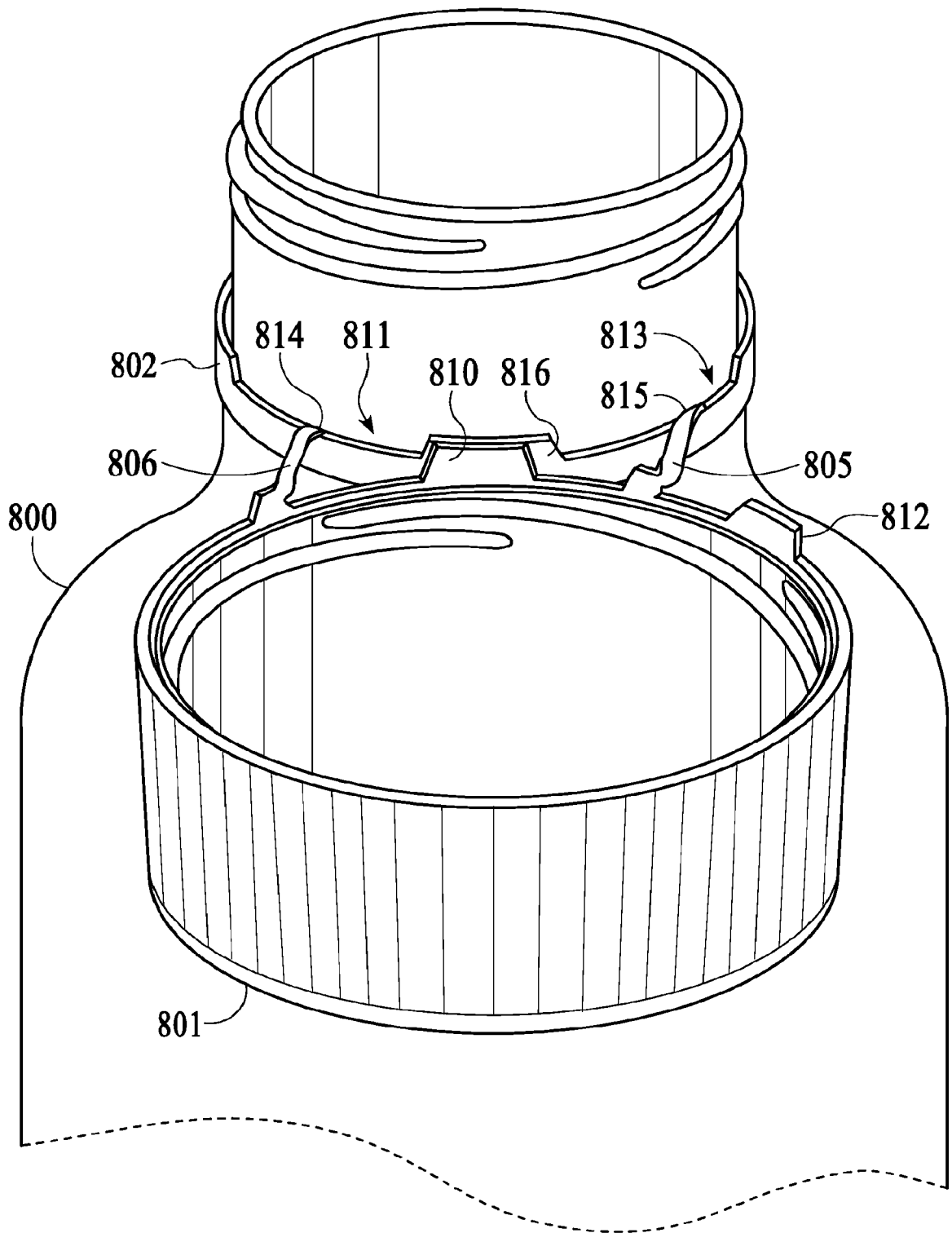

FIG. 37

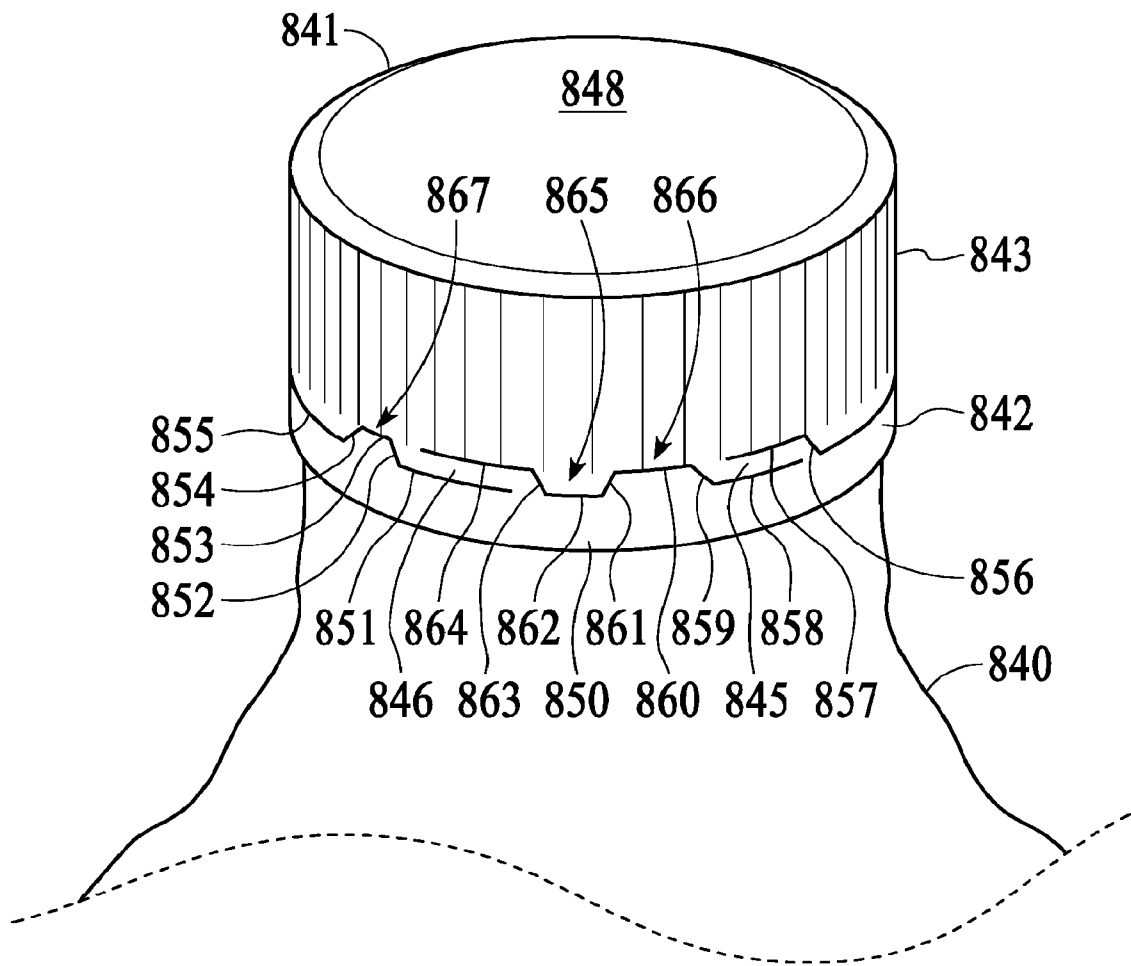

FIG. 38

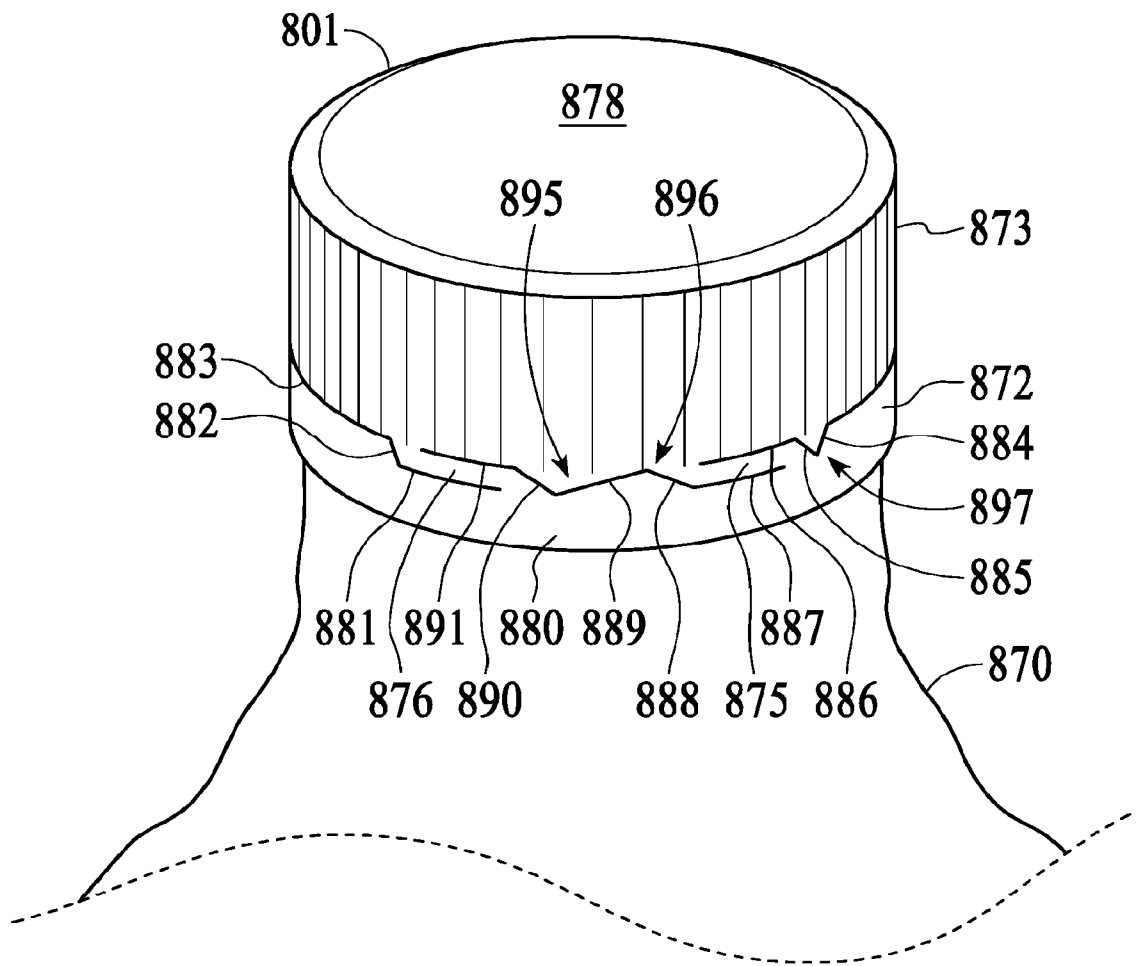

FIG. 39

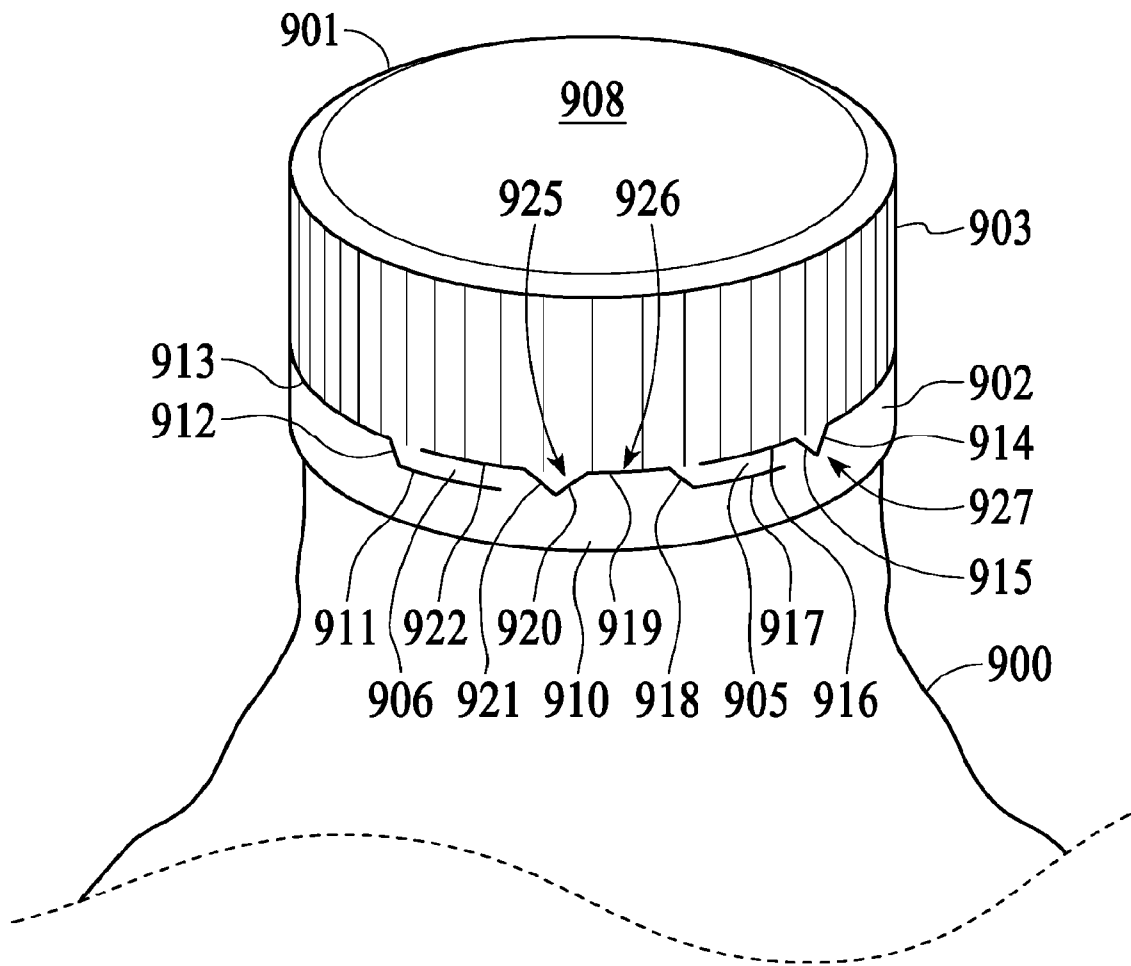

FIG. 40

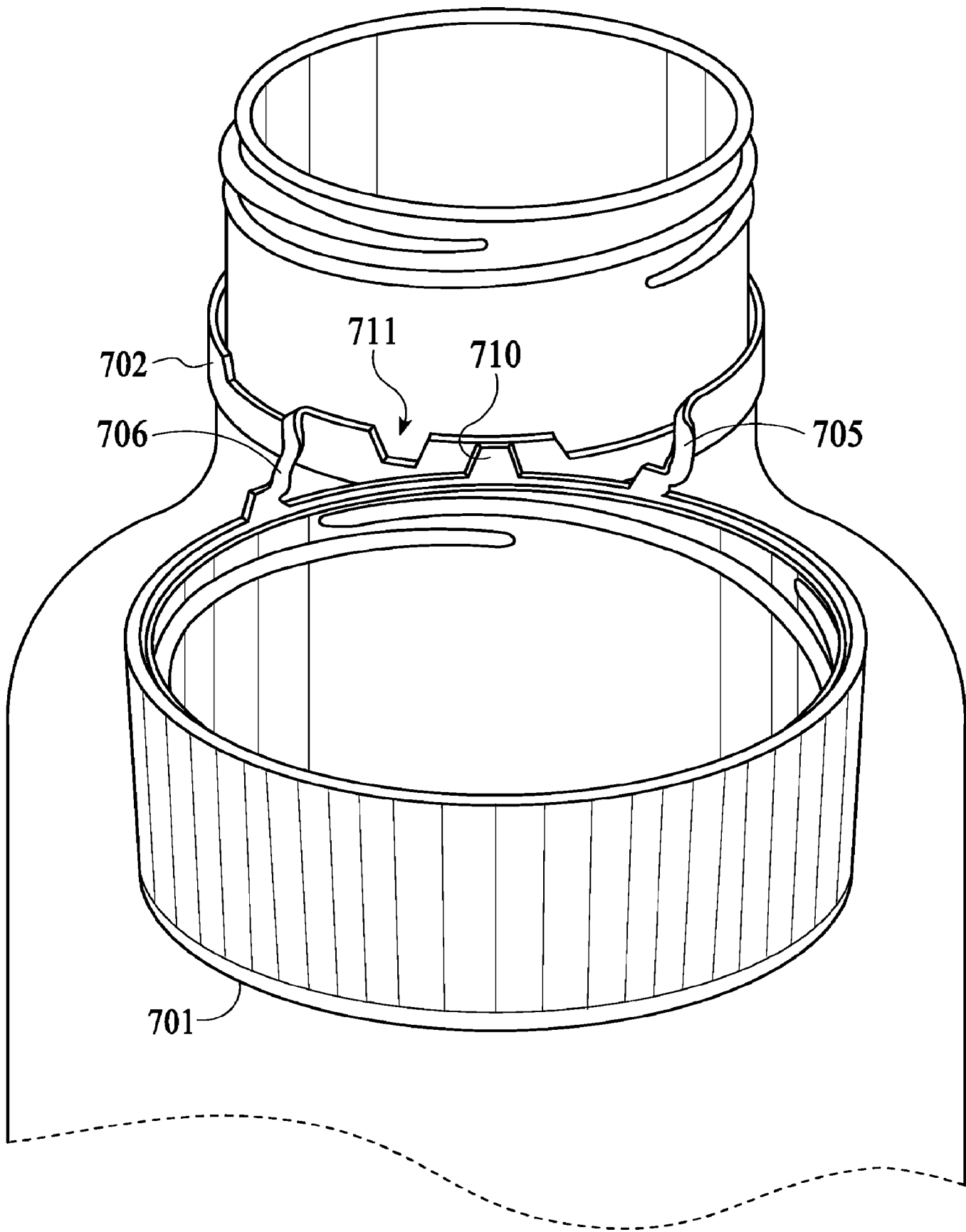

FIG. 34