

12

EUROPEAN PATENT APPLICATION

21 Application number: 89400170.0

51 Int. Cl.4: G 07 B 17/02

22 Date of filing: 20.01.89

30 Priority: 22.01.88 US 146919

43 Date of publication of application:
26.07.89 Bulletin 89/30

64 Designated Contracting States: CH DE FR GB LI

71 Applicant: **ALCATEL SATMAM**
113 rue Jean-Marie Naudin
F-92220 Bagneux (FR)

72 Inventor: **Haines, John Gregory**
5341 Golden Gate Avenue
Oakland California 94618 (US)

Rosenbaum, Nolan Glen
28864 Baltic Avenue
Hayward California 94544 (US)

Pion, Albert Louis
1461 Acton Crescent
Berkeley California 94702 (US)

Lecarpentier, Marc
124 avenue Saint Exupéry
F-92160 Antony (FR)

Henriot, Christophe
Ducy
F-60800 Crepy en Valois (FR)

Abumehdi, Cyrus
114 Copse Hill
Harlow Essex CM19 4PR (GB)

74 Representative: **Weinmiller, Jürgen et al**
Lennéstrasse 9 Postfach 24
D-8133 Feldafing (DE)

54 Normal/transparent mode postage meter.

57 An electronic postage meter with memory and a postage printing function having enhanced I/O capability. The meter, in addition to its normal mode of operation, has a transparent mode of operation wherein the meter keyboard and display can be utilized as a user interface to an external I/O device. During the transparent mode of operation the meter maintains control and security over the meter memory and print function.

FIG. 2

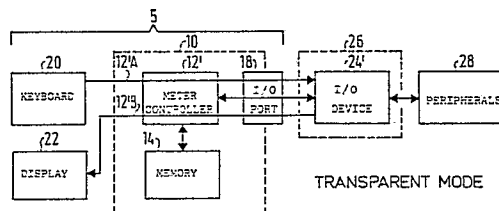

Description

NORMAL/TRANSPARENT MODE POSTAGE METER

Postage meters (hereinafter called "meters") are well known devices for printing postage impressions of desired value. A meter generally has a set of registers, a print mechanism and a controlling mechanism. The controlling mechanism acts to interlock the print mechanism and registers to ensure that all postage printed is accounted for. The registers, the print mechanism, and the meter controller are enclosed within a secure housing so as to be inaccessible to the user.

In modern electronic meters, the controlling mechanism is a microprocessor (hereinafter called "meter controller") and the registers are implemented as locations in random access memory (hereinafter called "meter memory"). The meter memory can be expanded to include accounting, cost allocation, or non-revenue information. External and permanently affixed to the housing is a keyboard for data entry to the meter controller and a display for data output to the user. In addition, an input/output port (hereinafter called "I/O port") may be provided so the meter controller can communicate with external devices. Many prior security measures are retained or improved. For example, the meter housing is still utilized to maintain physical security. The meter controller may utilize new techniques unique to electronic equipment to increase security for the meter memory.

In a typical configuration the meter is placed on a base from which it derives power. The base performs envelope handling and similar functions, and may include an input/output facility (hereinafter called "I/O device"). The I/O device can communicate with the meter through the meter's I/O port. The I/O device can also communicate with other peripherals external to the base such as scales and printers. For example, a scale may be used to weigh an article, calculate the cost of sending the article through the mail, and send that cost to the I/O device. The I/O device then tells the meter the denomination of postage to print. A user can also use an external user interface, such as the keyboard and display on a scale, to command the I/O device to generate a preprogrammed report. The I/O device then queries the meter controller for certain accounting or non-revenue information contained in the meter memory, formats that information, then commands a printer to print the report. However, in each case the meter controller does not initiate any commands to the I/O device, the meter controller merely responds to commands from the I/O device.

It is an object of the present invention to provide a postage meter in which the user is able to communicate directly with the I/O device.

According to the present invention, a postage meter, in communication with external devices and comprising user first input means for entering data, user first output means for displaying data, means for printing postage, means for storing data, second input means for entering data from external devices, second output means for writing data to

external devices, an I/O device for communication between said external devices and said input and output means, and computer means electrically connected to each of the aforesaid means and programmed for processing data and for controlling the operation of the postage meter in its normal mode of operation is characterized in that it furthermore comprises :

- first transfer means for transferring particular data entered on said user first input means to the second output means, when said computer means does not respond to said particular data,
- responsive means to said particular data in said I/O device for applying corresponding command data on said second input means,
- second transfer means for transferring data according to said command data to the user first output means,

wherein said first and second transfer means provide the postage meter, in addition to its normal mode, with a so-called transparent mode, where said computer means does not respond to the user first input entries.

In the transparent mode of operation, the meter controller determines whether a key press sequence on a keyboard has occurred, generates a command describing the key press sequence, then transmits that command through an I/O port to the I/O device. In addition, the I/O device can command the meter controller to put data onto a display. As a result, the user is able to communicate directly with the I/O device without requiring additional peripheral equipment.

In a preferred embodiment, when the meter in the normal mode sees an unknown key press sequence, it automatically generates a command describing the key press sequence and transmits that command to the I/O device. If the key press sequence is unknown to the I/O device, it is ignored, otherwise the I/O device will perform the command. As a result, limited communication with the I/O device is available to the user when the meter is in the normal mode. It is through this process that the user can use the keyboard to tell the I/O device to command the meter to enter the transparent mode.

While in the transparent mode, any key press sequence on the keyboard is passed directly to the I/O device by the meter controller. In addition, the display shows only data which the I/O device commands the meter to put on the display. The meter does not respond to the contents of the keyboard entries nor does it generate data to put on the display.

Because the keyboard and display are not under the control of the meter, the user is unable to control the meter printing function. The meter does not respond to the keyboard entries and the display does not tell the user what printing functions are occurring. Therefore with current applications, meter printing is disabled when the meter is in the transparent mode. However, future applications may

allow the I/O device to actuate the primary function under the control and security of the meter controller.

In order to go from the transparent mode back to the normal mode the user merely enters a predetermined data on the keyboard which is passed by the meter controller to the I/O device. The I/O device then commands the meter to return to the normal mode of operation. The meter also returns to the normal mode if it is powered down, then powered up again. However, if the I/O device is still in communication with the meter, it may command the meter to return to the transparent mode.

The above functions require changes to the protocol between the meter controller and the I/O device. The meter controller can now initiate communication with the status command and with commands describing what keys have been pressed by the user. In addition, the I/O device has new commands including commanding the meter controller to put certain data on the display.

Security is maintained in the transparent mode because the meter controller maintains control of communications between the meter memory and the I/O device thereby protecting the meter memory from unauthorized access or use. In addition, the meter controller does not respond to the keyboard entries because if the meter controller responded to both the keyboard entries and the I/O device, potential conflicts could occur.

Furthermore, the printing function is disabled with current applications to maintain security and prevent user confusion.

A further understanding of the nature and advantages of the present invention can be realized by reference to the remaining portions of the specification and attached drawings. In these drawings :

- Figure 1 is a block diagram showing a prior art or normal mode configuration of the meter in communication with external devices ;
- Figure 2 schematically shows the meter in communication with external devices while the meter is in the transparent mode ; and
- Figure 3 is a flowchart showing user communication with the meter controller and the I/O device through the keyboard.

Figure 1 is a block diagram showing a prior art or normal mode configuration of a postage meter in communication with external devices.

A meter 5 includes a secure meter housing 10 in which are located a meter controller 12, a meter memory 14, a print mechanism 16, and an I/O port 18. The meter controller communicates directly with each of the devices located in the housing and with a keyboard 20 and a display 22 that are external to the housing. Meter controller 12 controls the actions of and maintains the security for the devices located in the housing. The meter controller also communicates through the I/O port 18 to an I/O device 24 located in a meter base 26. The I/O device communicates directly with one or more peripheral devices 28 such as a scale a printer, a modem, a computer, and the like.

The meter controller communicates with the user through the keyboard and display, and can respond

to commands from the I/O device.

However, the meter cannot initiate commands to the I/O device. The I/O device communicates with the user through one of the peripheral devices, which is in most instances the scale. In the normal mode operation of the meter, the requisite postage is provided to the controller meter from the scale through the I/O device. An acknowledge message is transmitted from the meter controller to the scale through the I/O device and is indicated at a scale display, while, the meter controller controls the print mechanism 16 and meter memory 14.

Figure 2 schematically shows the meter in communication with external devices while the meter is in the transparent mode. Reference numbers corresponding to Figure 1 will be used.

A modified meter controller 12' continues to control the actions of and maintain the security for the meter memory 14, print mechanism and I/O port 18 located in the secure housing 10. The printing mechanism has been disabled and is not shown.

The meter controller determines whether a key press sequence on the keyboard 20 has occurred, generates a command describing the key press sequence, and transmits that command, via a first transfer link 12'A and through the I/O port 18, to a modified I/O device 24'. The I/O device can command the meter controller to put data on the display 22 as shown by a second transfer link 12'B. As a result, the user is able to communicate directly with the I/O device. In addition, the meter controller does not respond to the key entries nor does it generate data to put on the display.

Figure 3 is a flow chart showing user communication with the meter controller and the I/O device in the normal/transparent postage meter.

The user enters a key press sequence on the keyboard (100). The meter controller reads the key press sequence by scanning the keyboard (102). The meter controller then checks a software switch to determine whether the meter is in the normal mode or transparent mode (104). If the meter is in the normal mode, the meter controller looks at a function table in memory to determine whether the key press sequence references a valid meter function (106). If the key press sequence does describe a valid meter function, then the meter performs the function (108). Examples of valid meter controller functions include printing postage, displaying some data contained in memory, etc.

If the meter is in the transparent mode or if the key press sequence is not a valid meter function, then the meter generates a command describing the key press sequence and transmits that command to the I/O device (110). The command includes an opcode and a variable length data field. In this case, the opcode states that the command is describing a key press sequence. The data field describes the key press sequence. The I/O device then determines whether the key press sequence references a valid I/O device function (112). If the key press sequence does reference a valid function, the I/O device performs that function (114). Example of valid I/O device functions include controlling the meter to go into the transparent mode, to go back to the normal

5

10

15

20

25

30

35

40

45

50

55

60

65

mode, to put data on the display when the meter is in transparent mode.

The user is able to utilize this process to tell the I/O device to command the meter to go into the transparent mode or to go back to its normal mode. In addition in the transparent mode, any key press sequence is passed directly to the I/O device which can command the meter controller to put data on the display. In said transparent mode, the keyboard and the display are not under control of the meter controller.

The user is unable to control printing postage ; printing postage function of the meter is disabled.

In the present embodiment, the user presses *1 on the keyboard while the meter is in normal mode. Because *1 does not reference a valid meter function, the meter controller generates a command describing the *1 key press sequence and transmits the command to the I/O device. The I/O device recognizes the *1 sequence as a command to cause the meter to go into transparent mode. The I/O device then generates a command instructing the meter to go into the transparent mode and transmits that command to the meter controller. The meter controller then causes the meter to go into the transparent mode, then passes a command back to the I/O device telling it whether the change to transparent mode was successful.

The I/O device performs each valid I/O device function entered by the keyboard, when the meter is in its transparent mode.

Claims

1/ Normal/transparent mode postage meter in communication with external devices (28), comprising user first input means (20) for entering data, user first output means (22) for displaying data, means (16) for printing postage, means (14) for storing data, second input means (18) for entering data from external devices, second output means (18) for writing data to external devices, an I/O device (24) for communication between external devices and input and output means, and computer means (12, 12') electrically connected to each of the aforesaid means and programmed for processing data and for controlling the operation of the postage meter in its normal mode of operation, and characterized in that it furthermore comprises :

- first transfer means (12'A) for transferring particular data entered on said user first input means (20) to the second output means (18), when said computer means (12, 12') does not respond to said particular data,
- responsive means (24') to said particular data in said I/O device (24) for applying corresponding command data on said second input means (18), - second transfer means (12'B) for transferring data according to said command data to the user first output means (22), wherein said first and second transfer means (12'A, 12'B) provide the postage meter, in

addition to its normal mode, with a so-called transparent mode, where said computer means (12, 12') is not responsive to the user first input entries.

2/ Postage meter according to claim 1, characterized in that the first and second transfer means (12'A, 12'B) are enabled and disabled by a command on the second input means (18) from said responsive means (24').

3/ Postage meter according to claim 2, characterized in that when the first and second transfer means (12'A, 12'B) are enabled, the computer means (12, 12') is not responsive to the data transferred by the first and second transfer means.

4/ Postage meter according to claim 3, characterized in that when the first and second transfer means (12'A, 12'B) are enabled, the means (16) for printing postage is disabled.

5/ Postage meter according to claim 1, in which said computer means is able to read data on said user first input means and/or to perform meter valid functions when the meter is in its normal mode and said I/O device is programmed for processing data from said external devices to send to said computer means, characterized in that said first and second transfer means (12'A, 12'B) comprise programmed initiating means (104, 106, 110) in said computer means (12, 12') for initiating communication to said second output means (18) when the meter is in its transparent mode or when particular data on said first input corresponds to an unknown valid meter function, and in that said I/O device (24') is furthermore programmed for performing valid I/O device functions in response to said particular data transmitted on said second output means through said first transfer means, and said responsive means comprises programmed reading and control means (112, 114) for determining whether data onto said second output means does reference one of the valid I/O device functions and for enabling said first and second transfer means and performing that I/O device function when valid.

FIG. 1

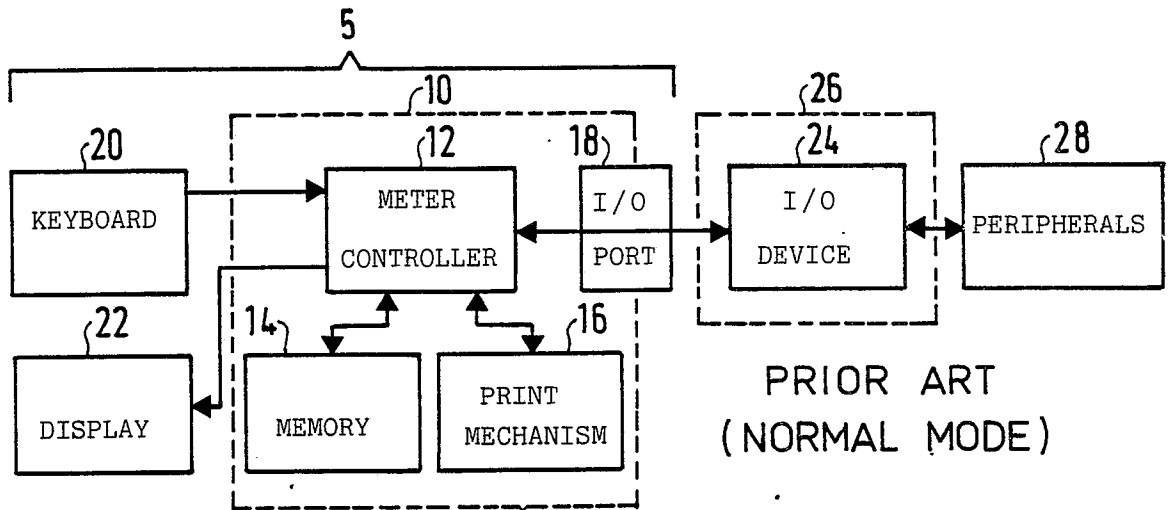

FIG. 2

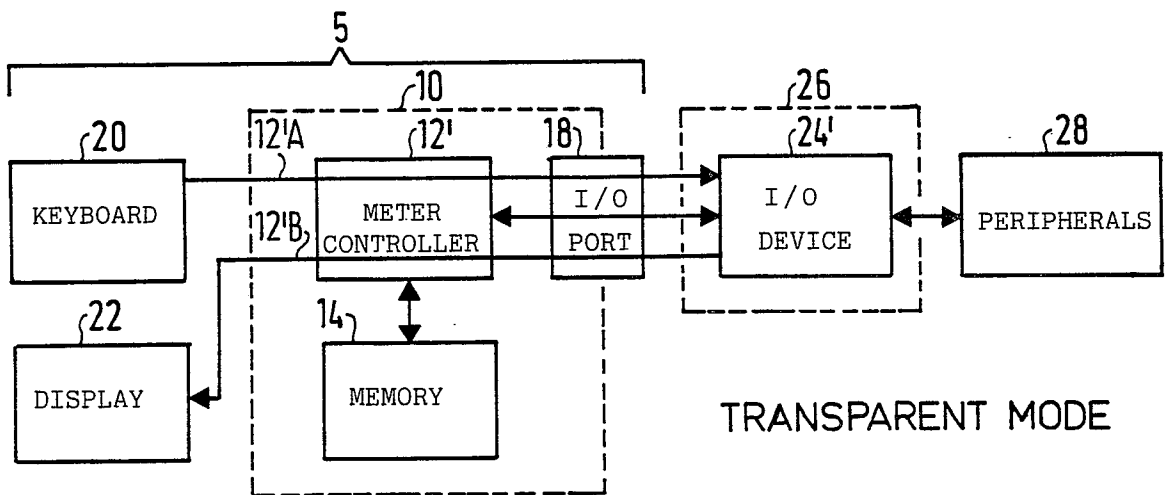

FIG. 3

