

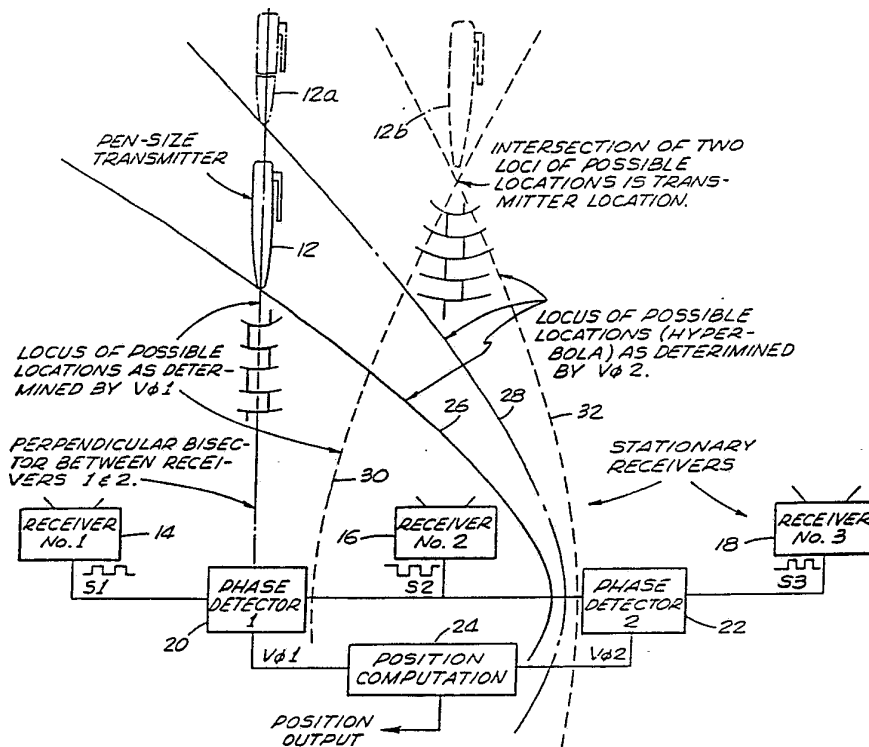

INTERNATIONAL APPLICATION PUBLISHED UNDER THE PATENT COOPERATION TREATY (PCT)

<p>(51) International Patent Classification ⁵ : G08C 21/00</p>	<p>A1</p>	<p>(11) International Publication Number: WO 90/07762 (43) International Publication Date: 12 July 1990 (12.07.90)</p>
<p>(21) International Application Number: PCT/US90/00048 (22) International Filing Date: 2 January 1990 (02.01.90) (30) Priority data: 292,947 3 January 1989 (03.01.89) US (71)(72) Applicant and Inventor: SCHIER, J., Alan [US/US]; 7105 Owens Street, Tujunga, CA 91042 (US). (74) Agent: DVORAK, George, F.; 53 West Jackson Blvd., Chicago, IL 60604 (US). (81) Designated States: AT (European patent), AU, BE (European patent), CA, CH (European patent), DE (European patent), DK (European patent), ES (European patent), FR (European patent), GB (European patent), IT (European patent), JP, KR, LU (European patent), NL (European patent), SE (European patent).</p>		<p>Published With international search report.</p>

(54) Title: POSITION DETERMINING APPARATUS



(57) Abstract

An apparatus for precisely locating the position of a transmitter (12) within either a plane or within a three dimensional space. More particularly the apparatus of the invention is adapted for use with a computer and includes a pen-sized movable transmitter (12), or mouse, whose exact position within a plane or three dimensional space can be determined without the use of any physical connection between the transmitter and the rest of the apparatus.

FOR THE PURPOSES OF INFORMATION ONLY

Codes used to identify States party to the PCT on the front pages of pamphlets publishing international applications under the PCT.

AT	Austria	ES	Spain	MG	Madagascar
AU	Australia	FI	Finland	ML	Mali
BB	Barbados	FR	France	MR	Mauritania
BE	Belgium	GA	Gabon	MW	Malawi
BF	Burkina Fasso	GB	United Kingdom	NL	Netherlands
BG	Bulgaria	HU	Hungary	NO	Norway
BJ	Benin	IT	Italy	RO	Romania
BR	Brazil	JP	Japan	SD	Sudan
CA	Canada	KP	Democratic People's Republic of Korea	SE	Sweden
CF	Central African Republic	KR	Republic of Korea	SN	Senegal
CG	Congo	LI	Liechtenstein	SU	Soviet Union
CH	Switzerland	LK	Sri Lanka	TD	Chad
CM	Cameroon	LU	Luxembourg	TG	Togo
DE	Germany, Federal Republic of	MC	Monaco	US	United States of America
DK	Denmark				

POSITION DETERMINING APPARATUS

SPECIFICATION

.Background of the Invention

Field of the Invention -

The present invention relates generally to a position determining apparatus. More particularly the invention concerns an input device for use with a computer in which the transmitter of the device, or mouse, is in the configuration of a pen sized writing instrument.

Discussion of the Prior Art -

The conventional prior art mouse comprises an input device, usually connected by a wire or other physical linkage to the computer. The mouse typically has a roller on its bottom designed to roll along the desk top beside the computer. When the mouse is moved, the cursor on the computer screen will move in the same direction that the mouse is moved.

The drawbacks of the conventional prior art mouse and the prior art position determining devices are several. In the first place, the shape of the mouse is ill-suited for use as a writing instrument and disadvantageously requires some physical connection with the computer system. Further, the conventional mouse only had the ability to determine position changes relative to a previous position as opposed to being able to determine an absolute position relative to a fixed reference. Additionally, unlike the device of the present invention, many prior art position locating devices must be used with a special surface such as a digitizing tablet. Finally, prior art position locating devices are typically two dimensional and cannot determine position three dimensionally.

Summary of the Invention

It is an object of the present invention to provide an apparatus for precisely locating the position of a transmitter within either a plane or within a three dimensional space. More particularly, it is an object of the invention to provide an input apparatus for use with a computer which includes a compact movable transmitter, whose exact position within a plane or three dimensional space can be determined without the

SUBSTITUTE SHEET

use of any physical connection between the transmitter and the rest of the apparatus.

It is another object of the invention to provide apparatus of the aforementioned character in which the transmitter had the shape of a writing instrument such as a pen.

It is another object of the invention to provide a device of the character described in the preceding paragraph in which the absolute position of the pen-sized transmitter can be precisely determined relative to a fixed reference.

Another object of the invention is to provide an apparatus of the character described which does not require the use of any special writing surface.

A further object of the invention is to provide an apparatus of the class described in which the transmitter comprises a laser diode driver and in which the apparatus includes photodiode receivers for receiving signals from the transmitter.

Brief Description of Drawings

Figure 1 is a generally perspective view of the one form of the apparatus of the invention.

Figure 2 is a generally diagrammatic view illustrating the interaction among the various subsystems which comprise the apparatus of the invention.

Figure 3 is a generally diagrammatic view illustrating the phase relationship of the transmitter signals at the three receivers of the apparatus with the transmitter in a first location.

Figure 4 is a diagrammatic view similar to Figure 3, showing the phase relationship of the signals at the three receivers with the transmitter in a second location.

Figure 5 is a generally diagrammatic view similar to Figures 3 and 4, but showing the phase relationship of the signals at the three receivers with the transmitter in a third location.

Figure 6 is a generally schematic view of the circuitry of the basic transmitter of one embodiment of the apparatus of

the invention.

Figure 7 is a generally schematic view illustrating the circuitry of the basic receiver of one embodiment of the apparatus of the invention.

Figure 8 is a generally schematic view showing the circuitry of basic phase detector of one form of the apparatus of the invention.

Figure 9 is a generally perspective view of an alternate embodiment of the apparatus of the invention.

Figure 10 is a generally diagrammatic view illustrating an alternate method of operation of the apparatus of the invention.

Figure 11 is a generally schematic view of one form of the phase detector device of the apparatus of the invention.

Description of the Invention

Referring to the drawings and particularly to Figures 1 and 2, one form of position determining apparatus of the present invention is there shown. In this embodiment of the invention the apparatus comprises transmitting means for transmitting a detectable signal and three co-planar, spaced apart receiving means for receiving the signal transmitted by the transmitting means. The transmitting means is here shown as comprising a housing 12 having the general configuration of a writing pen within which is mounted a laser diode adapted to emit a series of flashes of light. The receiving means, in turn, comprises first second and third receivers 14, 16, and 18 respectively, each being capable of sensing the flashes of light emitted by the laser diode. Upon sensing the flashes of light each receiver generates and transmits corresponding first output signals as, for example, electrical signals.

As best seen in Figure 2, the apparatus further includes first and second detector means here provided in the form of first and second phase detectors 20 and 22. Phase detector 20 is adapted to receive first output signals S1 and S2 from receivers 14 and 16 while phase detector 22 is adapted to receive first output signals S2 and S3 from receivers 16

and 18. Upon receiving signals S1 and S2 from receivers 14 and 16 respectively, phase detector 20 generates and transmits a second output signal V ϕ 1. Similarly, upon receiving signals S2 and S3 from receivers 16 and 18 respectively, phase detector 22 generates and transmits a third output signal V ϕ 2.

Cooperatively associated with phase detectors 20 and 22 is computation means shown here as a position computation device 24, for receiving and analyzing the second and third output signals transmitted by the phase detectors. The function and operation of the detector and computation means will be described more fully in the paragraphs which follow.

Referring now particularly to Figure 2, with the transmitter positioned as shown by the solid lines, the device functions as follows:

Consider first the receivers 14 and 16, that is, the receivers, numbered 1 and 2. In the position indicated by the solid lines and the numeral 12, the transmitter is equidistant from receivers 1 and 2. Turning to Figure 3, the signals detected by receivers 1 and 2, that is, S1 and S2 respectively, will be in phase with each other, and phase detector 1 will generate the appropriate second output signal, V ϕ 1.

From the signal V ϕ 1 it can be readily determined that the transmitter means must lie somewhere on a line which is equidistant from receivers 1 and 2. The line is shown in Figure 2 as the perpendicular bisector between receivers 1 and 2. The exact position of the transmitter means along this line can be determined from the signals available from receivers 2 and 3.

With the transmitter in the position shown by the solid lines, it is obviously closer to receiver 2 than it is to receiver 3. Accordingly, by referring again to Figure 3 it can be seen that the signal detected by receiver 2 will lead the signal S3 detected by receiver 3 and phase detector 2 will generate the appropriate third signal, V ϕ 2.

From V ϕ 2 it can be determined that the transmitter must lie on a line such that the distance from any point on the line to receiver 2 and the distance from the same point on the line

to receiver 3 are different by an amount (a constant) that results in a phase difference, d_1 , as indicated in Figure 3. This line is a hyperbola, designated in the drawings by the numeral 26, whose equation is determined uniquely by the phase difference d_1 as indicated by the third signal $V\phi_2$ and the distance between receivers 2 and 3.

Having signals $V\phi_1$ and $V\phi_2$ available, the position of the transmitter within the plane defined by receivers 1, 2, and 3 can be readily determined. To recapitulate, with the transmitter in the position shown by the solid lines in Figure 2, second signal $V\phi_1$ indicates that the transmitter lies on the perpendicular bisector between receivers 1 and 2. Further, third signal $V\phi_2$ indicates that the transmitter lies on the hyperbola 26 determined by the phase difference d_1 and the distance between receivers 2 and 3. Since the transmitter lies on both the hyperbola 26 and the perpendicular bisector, the transmitter must be at the intersection of the hyperbola and the bisector as illustrated in Figure 2.

The actual computation of the transmitter's position is carried out by the computation device 24. This device had as its input signals $V\phi_1$ and $V\phi_2$ from which the transmitter's position is determined.

If the transmitter's position is altered to that shown by the phantom lines 12a in Figure 2, it is still equidistant from receivers 1 and 2, but it is further away from the receivers. With the transmitter in this second position 12a, the operation of the apparatus is as follows:

Referring particularly to Figure 4, signals S1 and S2 are still in phase since the transmitter remains on the perpendicular bisector between receivers 1 and 2. The signal from phase detector 1, that is, second signal $V\phi_1$, still indicates this condition. However, as depicted in Figure 4, signal S2 still leads signal S3 as before since the transmitter is still closer to receiver 2 than to receiver 3. However, the phase difference d_2 is now smaller than d_1 since the distances from the transmitter to receivers 2 and 3 is more nearly equal. In Figure 4, the third signal $V\phi_2$, as determined by phase

detector 2, reflects this change.

As before, having signals $V\phi 1$ and $V\phi 2$, the position of the transmitter can readily be determined. Signal $V\phi 0$ again indicates that the transmitter is located on the perpendicular bisector between receivers 1 and 2, and signal $V\phi 2$ indicates that the transmitter lies on a hyperbola 28 determined by signal $V\phi 2$ and the distance between receivers 2 and 3. Since $V\phi 2$ had changed, the hyperbola on which the transmitter lies has also changed. As before since the transmitter lies on both the bisector and the hyperbola 28, it must be located at the point where the bisector and hyperbola 28 intersect. This position is readily calculated by the position computation means 24 using signals $V\phi 1$ and $V\phi 2$.

As a further illustration of the operation of this form of position determination apparatus, assume movement of the transmitter to the position 12b as indicated by the phantom lines designated as 12b in Figure 2. The operation of the apparatus is now as follows:

The location of the transmitter is such that it is closer to receiver 2 than it is to receiver 1. This results in signal $S2$ leading $S1$, or equivalently, $S1$ is delayed with respect to $S2$. This condition is illustrated in Figure 5. Correspondingly, signal $V\phi 2$ now indicates that $S2$ leads $S3$ by the amount $d4$.

With the transmitter in the location 12b, it no longer lies on a perpendicular bisector and a given hyperbola, but rather lies on two hyperbolae. One hyperbola 30 is uniquely determined by $V\phi 1$ and the distance between receivers 1 and 2, and the second hyperbola 32 is uniquely determined by $V\phi 2$ and the distance between receivers 2 and 3.

For the reasons previously discussed, the transmitter must lie on each of two different hyperbolae and more particularly must lie at the location 12b where the two hyperbolae 30 and 32 intersect.

It should be noted that in the simplified operation of the apparatus just described, information regarding the phase relationship between signals $S1$ and $S3$ was not used. In a

minimal realization, this information is not necessary. However, if desired, this extra information could be used to improve the accuracy of the apparatus. Such a scheme would be useful in rejecting "noise" and making the apparatus generally more precise.

Turning now to Figure 6 there is illustrated a simple embodiment of the laser diode driver used in the transmitter of the instant form of the apparatus of the invention. The laser diode illustrated in this figure functions to emit the transmitted first, or light flash, signal described in the preceding paragraphs. The laser diode driver is responsible for applying the necessary power to the laser diode at a frequency dictated by the input oscillator. The circuitry shown in Figure 6 is of a character well known to those skilled in the art and the details thereof will not be further described herein.

Referring to Figure 7, a simple receiver circuit is there illustrated. The signal from the transmitter is received by the photodiode detector. The detected signal is then passed to the phase detector in a manner well understood by those skilled in the art.

In Figure 8 a simple phase detector arrangement is shown. The first stage of the phase detector is a set-reset flip-flop whose inputs are driven by signals from two receivers. Due to the nature of set-reset flip-flops, if the two received signals are exactly in phase, the output of the flip-flop, "Q", is always low. If the two signals are π radians (180 degrees) out of phase, the output of the flip-flop is a 50% duty cycle square wave. If the two signals are 2π radians (360 degrees) out of phase, the output of the flip-flop will always be high. In this fashion, the duty cycle of the flip-flop output varies linearly with the phase difference between the two input signals.

Figure 8 also shows a low-pass filter following the output of the flip-flop. This filter has a cutoff frequency that is below the frequency of the input signals. Thus the filter allows only the DC and low-frequency components of the

flip-flop output to pass. If the flip-flop output is a 50% duty cycle square wave, the output of the low-pass filter will be a voltage that is 50% of the square wave peak voltage. The plot of output voltage versus phase angle shows how the output of the phase detector rises linearly as the phase angle between the two input signals increases. Once again the construction and operation of the phase detector subassembly illustrated in Figure 8 is well understood by those skilled in the art.

Before discussing alternate forms of the present invention, it is to be understood that the subsystems of the apparatus, that is the transmitter means, the receiver means, the detector means and the computation means can take several forms. The precise forms of the aforementioned means, as described in the preceding paragraphs and as illustrated in the drawings, are meant to be exemplary only. For example, the transmitter means can be such as to transmit various types of signals such as any electro-magnetic or acoustic radiation and any sort of modulation as, for example, frequency, amplitude, pulse width, phase and the like. Similarly the receiver means can take numerous forms adapted to receive the various types of signals that may be transmitted by the transmitter means. Additionally, the detector and computation means can take various forms of a character well understood by those skilled in the art, their precise form depending upon the end application of the apparatus of the invention.

Turning to Figure 10 an alternate approach for transmitter position determination with a plane is there schematically illustrated. The locations and configurations of the receivers, transmitter, and phase detector are substantially the same as described previously. However, analog-to-digital (A/D) converters have been shown for the purposes of explanation, but are not essential to the basic invention. Each of the A/D converters 36 and 38 has as its input the output of a phase detector here shown as phase detectors 1 and 2. In such a configuration, the output of the A/D converter is a digital word that is equal (within a known constant multiplier) to the phase difference between the input

signals to the phase detector. The digital word is also equal (within a known constant multiplier) to the difference between the distances from the transmitter to one receiver and from the transmitter to the other receiver.

The transmitter coordinates X and Y are the two unknown variables which are to be determined. Referring to Figure 10 and the geometric relationships illustrated therein, we have the following mathematical relationships:

Using the Pythagorean Theorem:

$$D_1^2 = y^2 + x^2$$

$$D_2^2 = y^2 + (a_1 - x)^2$$

$$D_3^2 = y^2 + (a_1 + a_2 - x)^2$$

From the Measurements from the Phase Detectors:

$$\Delta_1 = D_1 - D_2$$

$$\Delta_2 = D_3 - D_2$$

a_1 and a_2 are known values (distances between the receivers), as are Δ_1 and Δ_2 (values measured by the phase detectors).

The five unknown values are D_1 , D_2 , D_3 , X and Y. From these relationships, it is to be observed that there are 5 equations and 5 unknown variables. Given that the number of unknown variables is equal to the number of equations, these equations can be solved using any of a number of methods well known to those skilled in the art, a digital computer being one expedient means. With the equations solved, the transmitter coordinates X and Y will be known.

Referring now to Figure 9 an alternate form of the apparatus of the invention is shown. This embodiment, unlike that previously described and illustrated in Figures 1 and 2, is suitable for determination of the transmitter location within any three dimensional space. To accomplish this three dimensional location a fourth receiver 42 must be added. The other subsystems remain the same and like numerals have been used in the drawings to identify like components. The fourth receiver 42 must be noncoplanar with the previous three. With such a receiver, a third hyperbola can readily be determined which provides the third piece of information necessary to

locate the transmitter in three dimensions, the theory of operation and calculation remaining the same as previously described herein.

As previously discussed, most of the components of the apparatus of the invention are well known to those skilled in the art and are readily commercially available. For example, a laser diode of the character manufactured by the Sony Company and identified as SLD 301V, or any of a number of others may be used. In some applications, an LED such as manufactured by the Mitsubishi Company and identified as ME7022 can be used.

A Laser Diode Driver of the character manufactured by the Sony Company and identified as CXB1108Q, or any of a number of other integrated laser drivers may be used. Alternatively, the driver can be fabricated from discrete components as identified in Figure 6. If assembled from discrete components, the resistors, capacitor, and transistor may be selected from a number that are commonly available.

Photo Diode Detectors such as those manufactured by the Mitsubishi Company and identified as PD1002, as well as other photo diodes, may be used.

With respect to the Phase Detectors, set-reset flip-flops are typically configured from more generic logic gates. Shown in Figure 11 is a Sony CXB1104Q D-type flip-flop configured as an edge triggered set-reset flip-flop.

As to the Analog-to-Digital Converters, a device manufactured by Analog Devices and identified as AD578 is one of many A/D converters suitable for the present application.

In summary, it is to be understood that substantial departures from the embodiments of the invention described herein are possible without departing from the scope of the invention. Some possible departures from the apparatus as previously described are as follows:

As to the Transmitter:

- The transmitter need not be pen-shaped. It may be any suitable shape for the position location task at hand.
- The signal emitted by the transmitter could lie

anywhere within the electromagnetic spectrum or could be an acoustic signal. In principle, the emitted signal could be any form of energy that could be modulated and detected.

- The medium of operation need not be air, but could be a vacuum, water, or any other medium capable of conveying the energy emitted by the transmitter.

- The transmitter need not have only one point of emission of the transmitted energy. The precision of the locating function could be improved if another point of emission were added, and furthermore, the device would become useful for the determination of rotational orientation of the transmitter if additional emitters were added.

As to the Receivers:

- The receivers could be of any form suitable for converting the signal from the transmitter into a signal with which the necessary computations can be performed. For example, if the transmitted energy were acoustic, the receiver could be a microphone which converted the acoustic signal into an electrical signal.

- If more than a minimum number of receivers is used, the accuracy and reliability of the system can be improved. (The minimum number of receivers to determine the position of the transmitter along a line is two. The minimum number of receivers to determine the position of the transmitter within a plane is three. The minimum number of receivers to determine the position of the transmitter in three dimensional space is four.)

With respect to the Phase Detector:

- A wide variety of phase detectors well known to those skilled in the art are available other than the set-reset flip-flop type described herein, such as exclusive-or gates and various different types of mixers.

As to Position Computation:

- The position computation may be accomplished any of a number of ways, using either a digital or analog representation of the data.

Having now described the invention in detail in accordance with the requirements of the patent statutes, those skilled in this art will have no difficulty in making changes and modifications in the individual parts or their relative assembly in order to meet specific requirements or conditions. Such changes and modifications may be made without departing from the scope and spirit of the invention, as set forth in the following claims.

I CLAIM

1. A position determining apparatus, comprising:
 - (a) transmitter means for transmitting modulated signals;
 - (b) at least three spaced apart signal receiving means for receiving said modulated signals transmitted by said transmitter means for converting said signals to first output signals and then for transmitting said first output signals;
 - (c) a first detector means for receiving and analyzing said first output signals from a selected two of said signal receiving means and then to generate and transmit a second output signal;
 - (d) a second detector means for receiving and analyzing said first output signals from a selected different two of said signal receiving means to generate and then to transmit a third output signal;
 - (e) computation means for receiving said second and third output signals and for comparing said signals to determine the position of said transmitter means relative to said signal receiving means.

2. An apparatus as defined in Claim 1 in which said transmitter means comprises a light emitting means for emitting signals in the form of a series of flashes of light and in which said receiver means functions to receive said signals and convert said signals to first output signals in the form of electrical signals.

3. An apparatus as defined in Claim 2 in which said first and second detector means function to receive said electrical signals from said receiver means, to analyze said electrical signals to determine the phase thereof and to transmit first and second phase signals;

4. An apparatus as defined in Claim 3 in which said computation means functions to receive said first and second

phase signals, to compare said first and second phase signals and thereby determine the position of said transmitter means relative to said receiver means and to generate and transmit a fourth output signal.

5. An apparatus as defined in Claim 4 further including display means for receiving and displaying said fourth output signal.

6. A position determining apparatus, comprising:

(a) transmitter means for transmitting modulated signals;

(b) first, second and third, spaced apart, co-planar, signal receiving means for receiving said modulated signals and for converting said signals to electrical signals;

(c) a first detector means for receiving electrical signals from said first and second signal receiving means to determine the phase of said signals and to generate a first signal corresponding thereto;

(d) a second detector means operably associated with said first phase detector means for receiving electrical signals from said second and third signal receiving means to determine the phase of said signals and to generate a second signal corresponding thereto;

(e) computation means for receiving said first and second signals and for calculating the position of said transmitter means relative to said first, second and third signal receiving means.

7. An apparatus as defined in Claim 6 in which said computation means further functions to generate and transmit a signal defining the position of said transmitter means.

8. An apparatus as defined in Claim 7 in which said transmitter means comprises a generally pen-shaped housing and means for generating detectable radiation mounted within said housing.

9. A position determining apparatus, comprising:

(a) transmitter means for transmitting modulated signals;

(b) first, second and third, spaced apart, co-planer, signal receiving means and a fourth signal receiving means disposed in a non co-planer relationship with said first, second and third signal receiving means, each of said signal receiving means being adapted to receive said modulated signals and convert said signals to electrical signals;

(c) a first detector means for receiving electrical signals from said first and second signal receiving means to determine the phase of said signals and to generate a first signal corresponding thereto;

(d) a second detector means operably associated with said first phase detector means for receiving electrical signals from said second, third and fourth signal receiving means to determine the phase of said signals and to generate second and third signals corresponding thereto;

(e) computation means for receiving said first, second and third signals and for calculating the position of said transmitter means relative to said first, second and third and fourth signal receiving means.

10. An apparatus as defined in Claim 9 in which said transmitter means comprises a hand held housing including means for generating detectable radiation.

FIG. 1

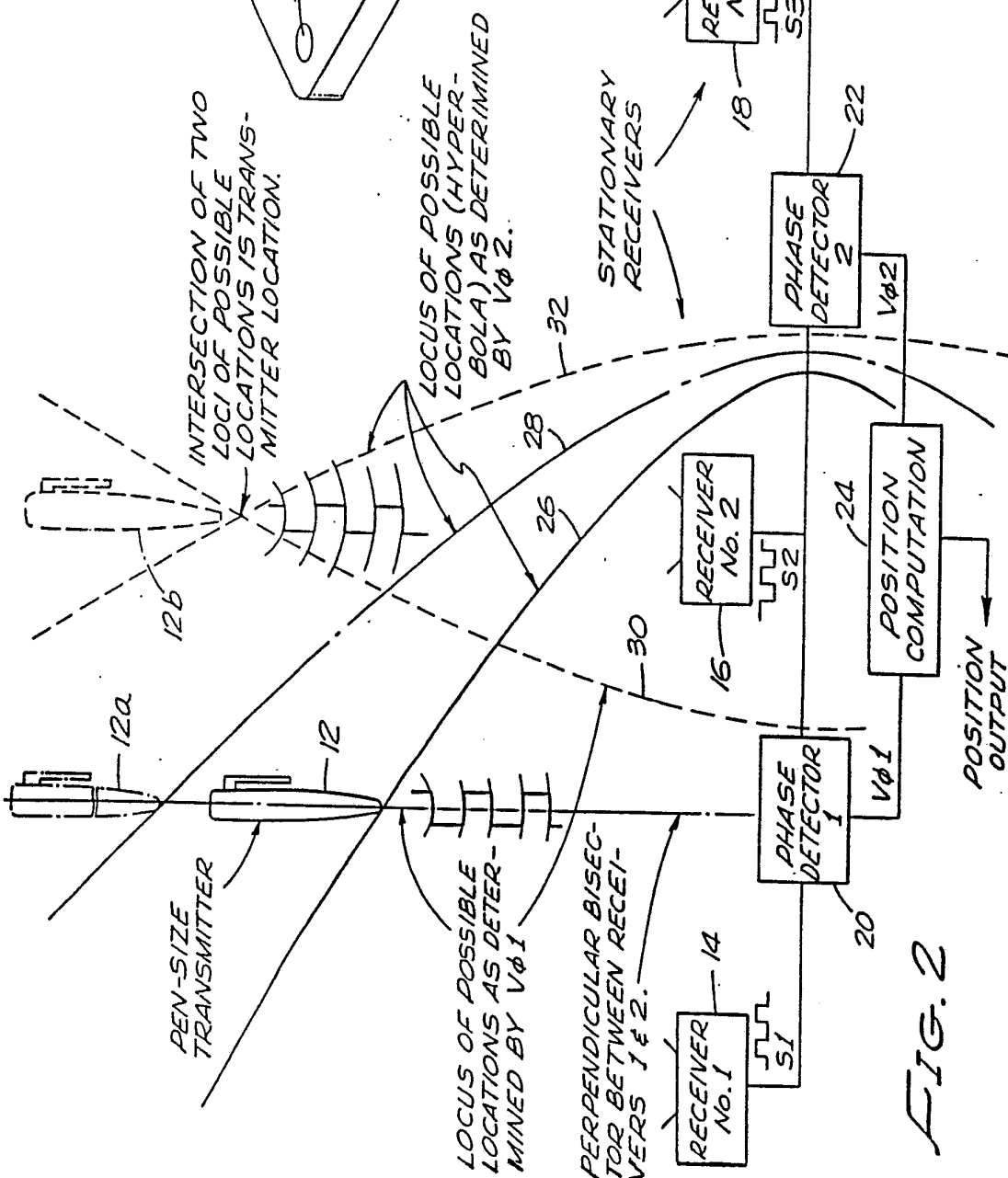
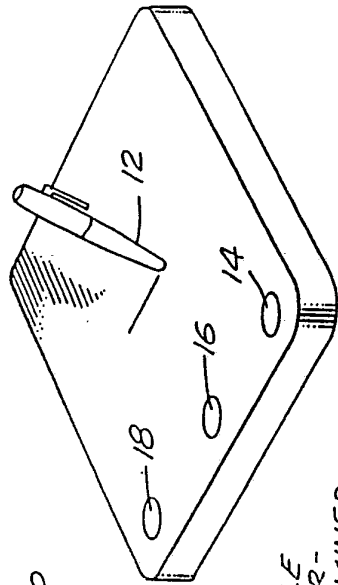

FIG. 11

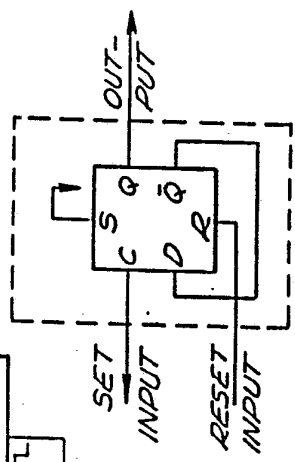

FIG. 2

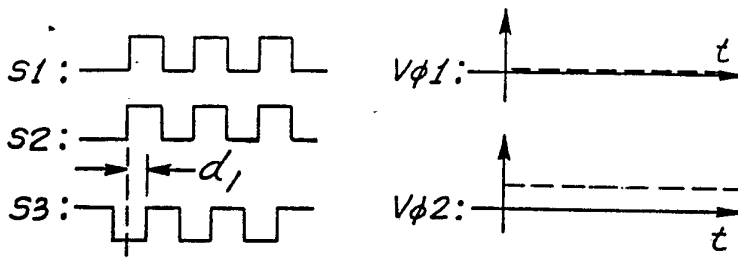

FIG. 3

S1, S2 IN PHASE, S3
DELAYED W.R.T. S2 FOR
CONFIGURATION SHOWN

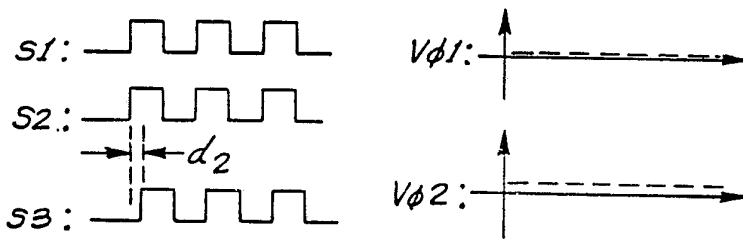

FIG. 4

S1, S2 IN PHASE, S3
DELAYED W.R.T. S2 FOR
CONFIGURATION SHOWN

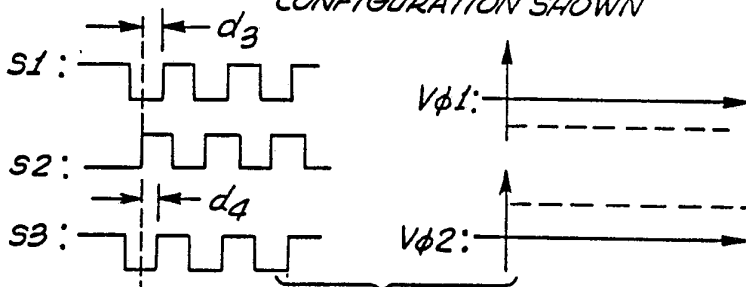

FIG. 5

S1, S3 DELAYED W.R.T.
S2 FOR THE CONF-
GURATION SHOWN.

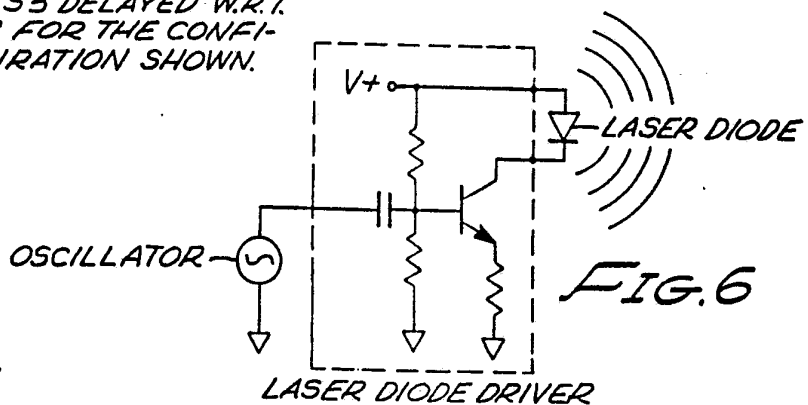

FIG. 6

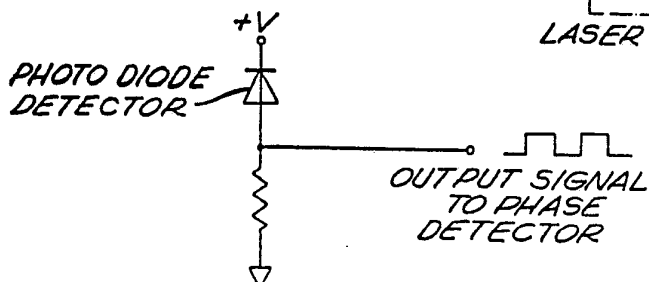

FIG. 7

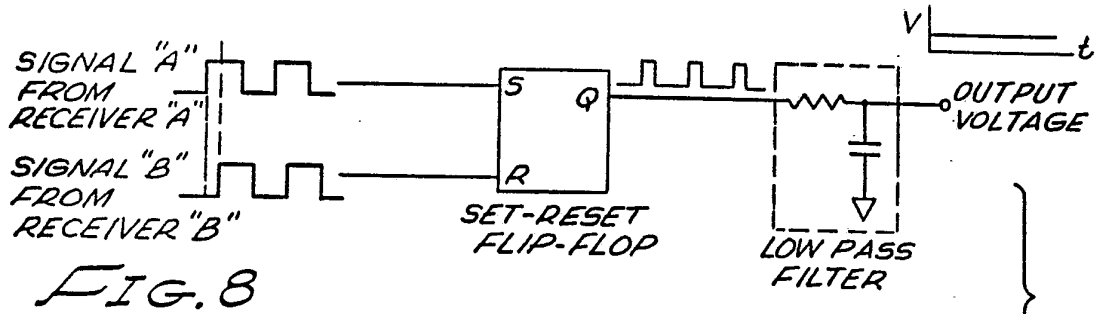

FIG. 8

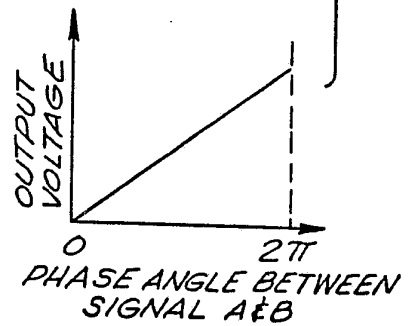
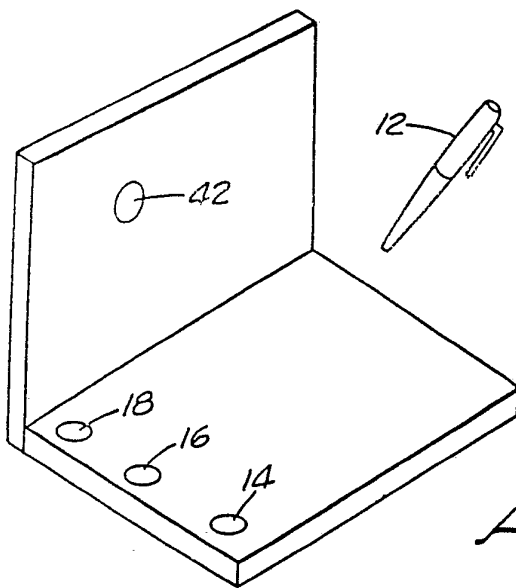

FIG. 9

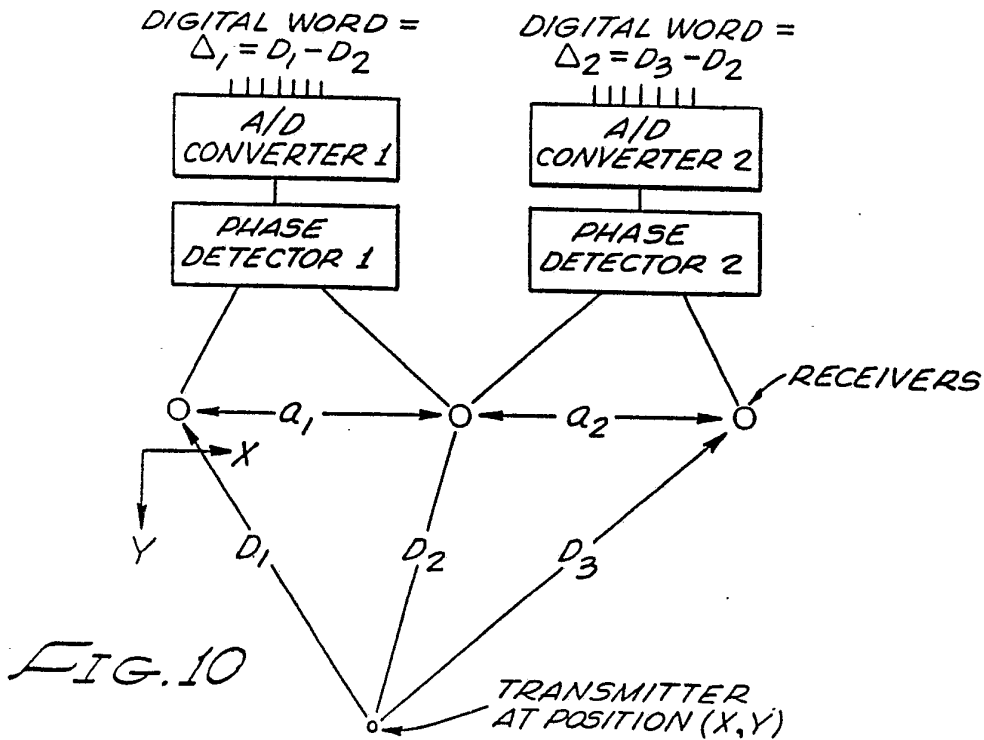

FIG. 10

INTERNATIONAL SEARCH REPORT

International Application No. **PCT/US90/00048**

I. CLASSIFICATION OF SUBJECT MATTER (if several classification symbols apply, indicate all) ⁶		
According to International Patent Classification (IPC) or to both National Classification and IPC		
INT. Cl(5) G08C 21/00		
US 178/19 340/707		
II. FIELDS SEARCHED		
Minimum Documentation Searched ⁷		
Classification System	Classification Symbols	
US	178/18,19 340/707	
Documentation Searched other than Minimum Documentation to the Extent that such Documents are Included in the Fields Searched ⁸		
III. DOCUMENTS CONSIDERED TO BE RELEVANT ⁹		
Category ¹⁰	Citation of Document, ¹¹ with indication, where appropriate, of the relevant passages ¹²	Relevant to Claim No. ¹³
A	US, A, 4,794,634, (Toriyata et al) 27 DECEMBER 1988	
<p>* Special categories of cited documents: ¹⁰</p> <p>"A" document defining the general state of the art which is not considered to be of particular relevance</p> <p>"E" earlier document but published on or after the international filing date</p> <p>"L" document which may throw doubts on priority claim(s) or which is cited to establish the publication date of another citation or other special reason (as specified)</p> <p>"O" document referring to an oral disclosure, use, exhibition or other means</p> <p>"P" document published prior to the international filing date but later than the priority date claimed</p> <p>"T" later document published after the international filing date or priority date and not in conflict with the application but cited to understand the principle or theory underlying the invention</p> <p>"X" document of particular relevance; the claimed invention cannot be considered novel or cannot be considered to involve an inventive step</p> <p>"Y" document of particular relevance; the claimed invention cannot be considered to involve an inventive step when the document is combined with one or more other such documents, such combination being obvious to a person skilled in the art.</p> <p>"&" document member of the same patent family</p>		
IV. CERTIFICATION		
Date of the Actual Completion of the International Search		Date of Mailing of this International Search Report
13 FEBRUARY 1990		13 MAR 1990
International Searching Authority		Signature of Authorized Officer
ISA/US		S.D. SCHREYER <i>E. Schreyer</i>