

(19)



(11) Publication number:

SG 181756 A1

(43) Publication date:

30.07.2012

(51) Int. Cl:

E04B 1/18;

(12)

Patent Application

(21) Application number: **2012044509**

(71) Applicant:

**PATCO, LLC 12885 MAX'S WAY, LAC
DU FLAMBEAU, WISCONSIN 54538 WS
US**

(22) Date of filing: **09.12.2010**

(30) Priority: **US 61/288,011 18.12.2009**

(72) Inventor:

**VANKER, JOHN LOUIS 12885 MAX'S
WAY LAC DU FLAMBEAU, WISCONSIN
54538 US
LASTOWSKI, MICHAEL J. 9079
EAST PANORAMA CIRCLE UNIT 405
CENTENNIAL, COLORADO 80112 US**

(54) **Title:**

**PANELIZED STRUCTURAL SYSTEM FOR BUILDING
CONSTRUCTION**

(57) **Abstract:**

Structural columns are fastened to one another vertically. Wall panels may be fastened to the structural columns so that load is transferred through the structural columns rather than vertically between the wall panels.

(19) World Intellectual Property Organization
International Bureau



(43) International Publication Date
23 June 2011 (23.06.2011)

(10) International Publication Number
WO 2011/075394 A1

(51) International Patent Classification:
E04B 1/18 (2006.01)

US]; 9079 East Panorama Circle, Unit 405, Centennial, Colorado 80112 (US).

(21) International Application Number:
PCT/US2010/059725

(74) Agent: **JOIKE, Trevor B.**; Schiff Hardin LLP, 233 S. Wacker Dr., Suite 6600, Chicago, Illinois 60606 (US).

(22) International Filing Date:
9 December 2010 (09.12.2010)

(81) Designated States (unless otherwise indicated, for every kind of national protection available): AE, AG, AL, AM, AO, AT, AU, AZ, BA, BB, BG, BH, BR, BW, BY, BZ, CA, CH, CL, CN, CO, CR, CU, CZ, DE, DK, DM, DO, DZ, EC, EE, EG, ES, FI, GB, GD, GE, GH, GM, GT, HN, HR, HU, ID, IL, IN, IS, JP, KE, KG, KM, KN, KP, KR, KZ, LA, LC, LK, LR, LS, LT, LU, LY, MA, MD, ME, MG, MK, MN, MW, MX, MY, MZ, NA, NG, NI, NO, NZ, OM, PE, PG, PH, PL, PT, RO, RS, RU, SC, SD, SE, SG, SK, SL, SM, ST, SV, SY, TH, TJ, TM, TN, TR, TT, TZ, UA, UG, US, UZ, VC, VN, ZA, ZM, ZW.

(25) Filing Language: English

(26) Publication Language: English

(30) Priority Data:
61/288,011 18 December 2009 (18.12.2009) US

(71) Applicant (for all designated States except US): **PATCO, LLC** [US/US]; 12885 Max's Way, Lac du Flambeau, Wisconsin 54538 (US).

(72) Inventors; and

(75) Inventors/Applicants (for US only): **VANKER, John Louis** [US/US]; 12885 Max's Way, Lac du Flambeau, Wisconsin 54538 (US). **LASTOWSKI, Michael J.** [US/

(84) Designated States (unless otherwise indicated, for every kind of regional protection available): ARIPO (BW, GH, GM, KE, LR, LS, MW, MZ, NA, SD, SL, SZ, TZ, UG, ZM, ZW), Eurasian (AM, AZ, BY, KG, KZ, MD, RU, TJ, TM), European (AL, AT, BE, BG, CH, CY, CZ, DE, DK,

[Continued on next page]

(54) Title: PANELIZED STRUCTURAL SYSTEM FOR BUILDING CONSTRUCTION

(57) Abstract: Structural columns are fastened to one another vertically. Wall panels may be fastened to the structural columns so that load is transferred through the structural columns rather than vertically between the wall panels.

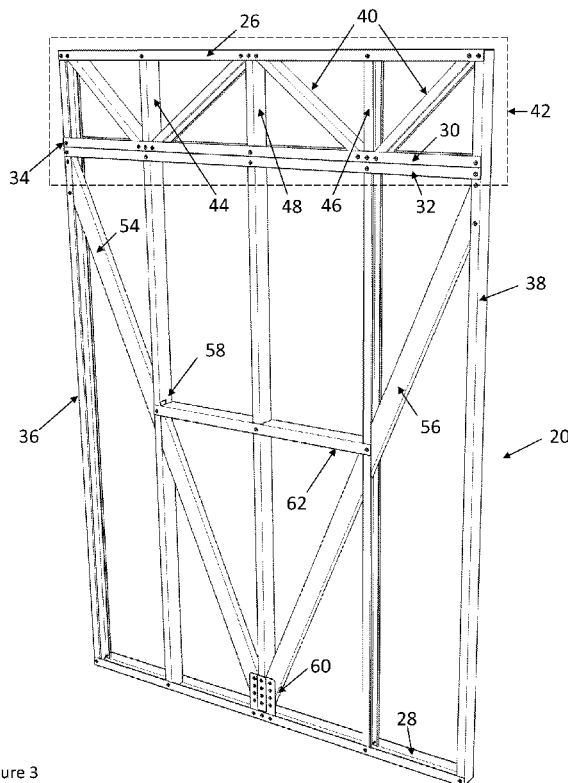

Figure 3

WO 2011/075394 A1

EE, ES, FI, FR, GB, GR, HR, HU, IE, IS, IT, LT, LU,
LV, MC, MK, MT, NL, NO, PL, PT, RO, RS, SE, SI, SK,
SM, TR), OAPI (BF, BJ, CF, CG, CI, CM, GA, GN, GQ,
GW, ML, MR, NE, SN, TD, TG).

— *as to the applicant's entitlement to claim the priority of
the earlier application (Rule 4.17(iii))*

Published:

Declarations under Rule 4.17:

— *as to applicant's entitlement to apply for and be granted
a patent (Rule 4.17(ii))*

— *with international search report (Art. 21(3))*

— *with amended claims (Art. 19(1))*

Panelized Structural System for Building Construction

Related Applications

The present application claims the benefit of
5 Provisional Application Serial No. 61/288,011 filed on
December 18, 2009.

Technical Field

The present disclosure relates to a panelized
10 and modular system for constructing and assembling
buildings,

Background

A building's structure must withstand physical
15 forces or displacements without danger of collapse or
without loss of serviceability or function. The stresses
on buildings are withstood by the buildings' structures.

Buildings five stories and less in height
typically use a "bearing wall" structural system to
20 manage dead and live load vertical forces. Vertical
forces on the roof, floors, and walls of a structure are
passed vertically from the roof to the walls to the
foundation by evenly spreading the loads on the walls and
by increasing the size and density of the framing or
25 frame structure from upper floors progressively downward

to lower floors, floor-to-floor. For ceilings and floor spans, trusses are used to support loads on the ceilings and floors and to transfer these loads to walls and columns.

5 Where vertical bearing elements are absent, for example at window and door openings, beams are used to transfer loads to columns or walls. In buildings taller than five stories, where the walls have limited capacity to support vertical loads, concrete and/or structural
10 steel framing in the form of large beams and columns are used to support the structure.

 Lateral forces (e.g., wind and seismic forces) acting on buildings are managed and transferred by bracing. A common method of constructing a braced wall
15 line in buildings (typically 5 stories or less) is to create braced panels in the wall line using structural sheathing. A more traditional method is to use let-in diagonal bracing throughout the wall line, but this method is not viable for buildings with many openings for
20 doors, windows, etc. The lateral forces in buildings taller than five stories are managed and transferred by heavy steel let-in bracing, or heavy steel and/or concrete panels, as well as structural core elements such

as concrete or masonry stair towers and elevator hoistways.

There is a need for a panelized and modular system for constructing and assembling buildings without
5 relying on concrete and/or structural steel framing, heavy steel let-in bracing, and heavy steel and/or concrete panels.

Brief Description of the Drawings

10 Figure 1 illustrates a stud for use as a framing member in horizontal truss panels;

Figure 2 illustrates a track for use as a framing member in horizontal truss panels;

15 Figures 3 and 3.1 illustrate a V-Braced horizontal truss panel;

Figures 4, 4.1, and 4.2 illustrate various open horizontal truss panels;

Figure 5 illustrates a truss for attachment to horizontal truss panels;

20 Figure 6 illustrates a structural column assembly for attaching horizontal truss panels to one another;

Figures 7 and 8 show the manner of attaching a horizontal truss panel such as shown in Figures 3, 3.1,

4, 4.1, and 4.2 to the structural column assembly of Figure 6;

Figure 9 shows a unified horizontal truss panel wall line having open and V-braced horizontal truss panels in a Unified Truss Construction System (UTCS) wall line;

Figure 10 illustrates the truss of Figure 5;

Figure 11 shows the truss/stud hangar of Figure 6;

Figure 12 illustrate a portion of the structural column assembly of Figure 6;

Figure 13 illustrates trusses connected to horizontal truss panels;

Figure 14 illustrates trusses connected to horizontal truss panels to form a UTCS open span assembly creating a wall line;

Figure 15 illustrates a UTCS building section formed as an assembly of multiple floors of a UTCS structure;

Figure 16 shows alignment of the structural column assemblies of Figure 6 in a building;

Figure 17 illustrates a three-dimensional view and a two-dimensional view of the floor-to-floor sections of a section of this building; and,

Figure 18 shows the transfer of forces to the structural column assemblies of Figure 6.

Detailed Description

5 The Unified Truss Construction System (UTCS) disclosed herein is a unique, new, and innovative structural system for single and multistory buildings, based on standardized structural panels. The system employs a limited number of configurations of uniquely
10 engineered, light gauge metal framed vertical wall panels (horizontal truss panels), light-gauge-metal floor and ceiling trusses, cold rolled square or rectangular steel tubing (structural columns), and unique connecting plates and clips.

15 Unlike conventional approaches to designing and engineering a building's structure, where many different assemblies (walls, columns, beams, bracing, strapping, and the fasteners that fasten them together) are employed to manage vertical live load and dead load forces, and
20 lateral forces, UTCS manages these forces through a limited number of uniquely designed standardized horizontal truss panels, which are assembled with structural columns and trusses. This unique assembly of elements effectively supports and transfers vertical and

lateral forces from the walls, floor, ceiling, and roof to UTCS' redundant and dense column system. Accordingly, columns absorb these vertical and lateral forces such that UTCS is not a vertical bearing wall structural system and eliminates the need for "hot formed" structural steel (weighted steel or "red iron") and concrete as part of a building's structural system.

UTCS framing members are made from specially designed computerized roll forming machines. These machines manufacture framing studs or members from cold rolled steel commonly referred to as "coiled steel." Each stud is cut to size, pre-drilled for fastening screws, with countersinks at the assembly screw head area, pre-punched for chasing mechanical, electrical, and plumbing ("MEP") assemblies and rough-ins, pre-punched for passing vertical and horizontal bracing, and labeled for assembly. The machines read stud specifications from CAD files.

Horizontal truss panels and the trusses used in UTCS are constructed with framing members roll formed from light gauge steel, such as 18 to 14 gauge steel, depending on building height and code requirements. There are two profiles of framing members used in the horizontal truss panels, a stud 10 illustrated in Figure

1 and a track 12 illustrated in Figure 2. The stud 10 and the track 12 are each rolled from light gauge steel, such as 18 to 14 gauge steel.

Each of the stud 10 and the track 12 includes a web 14, flanges 16, and lips 18 formed as illustrated in Figure 1. The flanges 16 extend in the same direction at substantially right angles from opposing sides of the web 14, and the lips 18 extend inwardly from ends of the flanges 16 such that the lips 18 parallel the web 14.

10 The stud 10 and the track 12 differ mainly in that the flanges 16 of the track 12 are slightly higher than the flanges 16 of the stud 10, and the web 14 of the track 12 is slightly wider than the web 14 of the stud 10. These relative dimensions allow the stud 10 to slide into or

15 through the track 12 without the need to compress the flanges 16 of the stud 12, which affects its structural performance.

UTCS employs a limited number, such as two, configurations of horizontal truss panels. These

20 horizontal truss panels are the structural wall elements of UTCS. If only two such configurations are used, they are (a) a V-braced horizontal truss panel 20/22 shown in Figure 3 or Figure 3.1, which contains a "V" shaped brace

("V-brace"), and (b) an open horizontal truss panel 24 shown in Figure 4, which does not contain a V-brace.

An open horizontal truss panel 24 is generally used in any area of a building having large openings (windows, doors, pass-throughs, and the like) in a UTCS structure. The open horizontal truss panel 24 is engineered to support and transfer vertical live (occupancy, for example) and dead load forces (e.g., drywall, MEP assemblies, insulation, and the like) from floor and ceiling assemblies attached either to or proximate to each panel within a building ("Local Forces"). The V-braced horizontal truss panel 20/22 is engineered to support vertical local forces and lateral forces acting on the structure (wind and seismic, for example).

As shown in Figure 3, the V-braced horizontal truss panel 20 has a top track 26 and a bottom track 28. Inboard of the top track 26 is a continuous horizontal brace comprised of back-to-back (web-to-web) tracks 30 and 32, (referred to as double horizontal bracing), which are anchored by fasteners 34 such as bolts or screws to side studs 36 and 38 at the sides of the V-braced horizontal truss panel 20. The top track 26 and the bottom track 28 are also anchored by fasteners 34 to the

side studs 36 and 38. The area between the continuous horizontal brace formed by the tracks 30 and 32 and the top track 26 contains vertical angled webbing 40 made from studs. This braced area in Figure 3 acts as a truss attachment area 42 within the V-braced horizontal truss panel 20 for the attachment of trusses 106 discussed below, and supports and transfers forces exerted on the V-braced horizontal truss panel 20 to the structural columns discussed below and attached to each of the side studs 36 and 38 of the V-braced horizontal truss panel 20.

The V-braced horizontal truss panel 20 also has two inboard studs 44 and 46 and a center stud 48 anchored by fasteners 34 to the top and bottom tracks 26 and 28 and to the tracks 30 and 32. The side studs 36 and 38 pass through end cutouts 50 in the ends of the web 14 and in the lips 18 of the tracks 30 and 32 such that the flanges 16 of the studs 36 and 38 abut the flanges 16 at the ends of the tracks 26, 28, 30, and 32. These end cutouts 50 are shown in Figure 2. The fasteners 34 are at these abutment areas. Similarly, the inboard studs 44 and 46 and the center stud 48 pass through interior cutouts 52 of the webs 14 and lips 18 of the tracks 30 and 32 such that an exterior of the flanges 16 of the

studs 36 and 38 and of the center stud 100 abut the interior of the flanges 16 of the tracks 26, 28, 34, and 36. These interior cutouts 52 are also shown in Figure 2. The fasteners 34 are at these abutment areas. The 5 five vertical studs 36, 38, 44, 46, and 48, for example, may be spaced 24" on center. The point at which the inboard studs 44 and 46 and the center stud 48 pass through the tracks 30 and 32 is a hinge connection (i.e., a single fastener allows for rotation). The studs of the 10 V-braced horizontal truss panel 20 also serve to support drywall, conduit, wiring, plumbing assemblies, etc.

The V-braced horizontal truss panel 20 also contains a continuous V-shaped bracing. This V-Bracing is unique in its design and engineering. The two legs of 15 the V-brace are V-brace studs 54 and 56 such as the stud 10 shown in Figure 1. The V-brace stud 54 is anchored to the side stud 36 just below the tracks 30 and 32 and to the bottom track 28 by the fasteners 34 and passes through an interior cutout 58 in the web 14 of the 20 inboard stud 44. This interior cutout 58 is shown in Figure 1. The web 14 of the V-brace stud 54 abuts one flange 16 of each of the studs 36 and 44 and the track 28. These abutment areas receive the fasteners 34 as shown.

Similarly, the V-brace stud 56 is anchored to the side stud 38 just below the tracks 30 and 32 and to the bottom track 28 by the fasteners 34 and passes through the interior cutout 58 in the inboard stud 46.

5 The web 14 of the V-brace stud 56 abuts one flange 16 of each of the studs 38 and 46 and the track 28. These abutment areas receive the fasteners 34 as shown.

The attachment of the V-brace studs 54 and 56 to the studs 36 and 38 and to the track 28 require that

10 the ends of the V-brace studs 54 and 56 be angles as shown in Figure 3. These angled ends permit multiple fasteners 34 to be used to anchor the V-brace studs 54 and 56 to their corresponding side studs 36 and 38.

The V-brace studs 54 and 56 are positioned with

15 their webs perpendicular to the webs of the studs 36, 44, 48, and 38 of the V-braced horizontal truss panel 20. Also, the V-brace studs 54 and 56 run continuously from immediately below the tracks 32 and 34 through the inboard studs 44 and 46 to the apex of a "V" at

20 substantially the middle of the bottom track 28. The connection at the apex of the V-bracing is facilitated by an apex plate 60 and additional fasteners 34, which interconnect the V-brace studs 54 and 56 and the center stud 48. The plate 60, the bottom track 28, and the stud

48 and the V-brace studs 54 and 56 are interconnected by the lower three fasteners as shown in Figure 3. The inboard stud 46 is also attached by fasteners 34 to the top track 26 and to the tracks 30 and 32 at the point
5 where the inboard stud 46 passes through the interior cutouts 52 in the tracks 30 and 32. The apex plate 60 may be formed from a material such as 18 - 14 gauge cold roll steel.

The connections of the V-brace studs 54 and 56,
10 to the side studs 36 and 38, to the center stud 48, and to the track 28 are moment connections and improve the lateral structural performance of the V-braced horizontal truss panel 20.

These connections facilitate the transfer of
15 most of the lateral forces acting on the V-braced horizontal truss panel 20 to the structural column of the system (discussed in further detail below).

The V-braced horizontal truss panel 20 also contains a track 62 providing horizontal bracing. The
20 track 62 is located, for example, mid-way in the V-Brace formed by the V-brace studs 54 and 56. The track 62 has the end cutouts 50 to accommodate the inboard studs 44 and 46, has the interior cutout 52 to accommodate the center stud 48, and is anchored by fasteners 34 to the

inboard studs 44 and 46 and to the center stud 48. The track 62 contributes to the lateral-force structural performance of the V-braced horizontal truss panel 20.

The V-braced horizontal truss panel 20 may contain other bracing and backing as necessary for building assemblies like drywall, cabinets, grab bars and the like. The V-braced horizontal truss panel 20 is used as both interior (demising and partition) structural walls and exterior structural walls. The V-braced horizontal truss panel 20/22 may also accommodate windows and pass-throughs, although the space is limited as can be seen from the drawings.

The V-braced horizontal truss panel 22 of Figure 3.1 has the same construction as the V-braced horizontal truss panel 20 of Figure 3 except that the V-brace stud 54 forming half of the V-brace of Figure 3 is replaced by two studs 64 and 66 whose lips 18 abut one another, and the V-brace stud 56 forming the other half of the V-brace of Figure 3 is replaced by two studs 68 and 70 that may or may not abut one another. Thus, the studs 64, 66, 68, and 70 form a double V-brace for the V-braced horizontal truss panel 22 of Figure 3.1 to provide extra strength.

As shown in Figure 4, the open horizontal truss panel 24 has a top track 80 and a bottom track 82. Inboard of the top track 80 is a continuous horizontal brace comprised of back-to-back (web-to-web) tracks 84 and 86, (referred to as double horizontal bracing), which are anchored by fasteners 34 such as bolts or screws to side studs 88 and 90 at the sides of the open horizontal truss panel 24. The top track 80 and the bottom track 82 are also anchored by fasteners 34 to the side studs 88 and 90. The area between the continuous horizontal brace formed by the tracks 84 and 86 and the top track 80 contains vertical angled webbing 92 made from studs. This braced area in Figure 4 acts as a structural truss 94 for the open horizontal truss panel 24, and supports and transfers forces exerted on the open horizontal truss panel 24 to the structural columns discussed below and attached to each of the side studs 88 and 90 of the open horizontal truss panel 24.

The open horizontal truss panel 24 also has two inboard studs 96 and 98 and a center stud 100 anchored by fasteners 34 to the top and bottom tracks 80 and 82 and to the tracks 84 and 86. The side studs 88 and 90 pass through end cutouts 50 in the ends of the web 14 and of the lips 18 of the tracks 84 and 86 such that the flanges

16 of the studs 88 and 90 abut the flanges 16 at the ends
of the tracks 80, 82, 84, and 86. These end cutouts 50
are shown in Figure 2. The fasteners 34 are at these
abutment areas. Similarly, the inboard studs 96 and 98
5 and the center stud 100 pass through interior cutouts 52
of the webs 14 and of the lips 18 of the tracks 84 and 86
such that the flanges 16 of the studs 96 and 98 and of
the center stud 100 abut the flanges 16 of the tracks 80,
82, 84, and 86. These interior cutouts 52 are also shown
10 in Figure 2. The fasteners 34 are at these abutment
areas. The five vertical studs 88, 90, 96, 98, and 100,
for example, may be spaced 24" on center. The point at
which the inboard studs 96 and 98 and the center stud 100
pass through the tracks 84 and 86 is a hinge connection
15 (i.e., a single fastener allows for rotation). The studs
of the open horizontal truss panel 24 also serve to
support drywall, conduit, wiring, plumbing assemblies,
etc.

The open horizontal truss panel 24 also
20 contains a track 102 performing horizontal bracing. The
track 102 is located, for example, mid-way between the
tracks 82 and 86. The horizontal bracing track 102
includes the end cutouts 50 through which the side studs
88 and 90 pass, has three interior cutouts 52 through

which the inboard studs 96 and 98 and the center stud 100 pass, and is anchored by fasteners 34 to the side studs 88 and 90, to the inboard studs 44 and 46, and to the center stud 48. The flanges 16 of the studs 88, 90, 96, 5 98, and 100 abut the flanges 16 of the track 102. The fasteners 34 are applied to these abutment areas. The open horizontal truss panel 24 is engineered to handle vertical local forces.

The open horizontal truss panel 24 is designed 10 to accommodate windows, doors, and pass-throughs. The open horizontal truss panel 24, for example, may be 20' wide or less. Figures 4.1 and 4.2 illustrate open horizontal truss panels with one or more openings for windows, doors, and pass-throughs. Figure 4.1 15 illustrates typical chase openings 104 through which MEP assemblies may be passed. These chase holes 104 may be formed in the V-braced horizontal truss panels 20 and 22 as well. Figure 4.2 illustrates several open horizontal truss panels with openings for doors.

20 The open horizontal truss panel 24 may contain other bracing and backing as necessary for building assemblies like windows, doors, pass throughs, drywall, cabinets, grab bars and the like. The open horizontal truss panel 24 is used as both interior (demising and

partition) structural walls and exterior structural walls.

The horizontal truss panels described above are tall enough to accommodate the floor to ceiling areas of buildings, and to accommodate attachment of trusses, such as a truss 106 shown in Figure 5. The truss 106 is attached to the truss attachment area 42 and includes a top stud 108 and a bottom stud 110 interconnected by an angled webbing 112 made from studs such that the angled webbing 112 is attached to the top and bottom studs 108 and 110 by the fasteners 34. The truss 106 is attached to the truss attachment area 42 of a horizontal truss panel 114 by use of truss/stud hangars 116 and the fasteners 34. Although the horizontal truss panel 114 is shown as the V-braced horizontal truss panel 20/22, the horizontal truss panel 114 can be any of the horizontal truss panels described herein. The truss/stud hangars 116 are discussed more fully below in connection with Figure 11.

The truss hangars 116 may be formed from a material such as 18 - 14 gauge cold roll steel.

The truss 106 is also shown in Figure 10. Trusses used in UTCS are made from the studs 10. These trusses have the top and bottom studs 108 and 110 and the

internal angled webbing 112. The trusses 106 do not have side or end webbing connecting their top and bottom chords 108 and 110. The truss 106 may be formed from light gauge steel, such as 18 to 14 gauge steel. The gauge and length of the truss 106 varies depending on application and width of floor span.

Figure 6 illustrates a structural column assembly 130 that includes a structural column 132 having a top plate 134 and a bottom plate 136 welded to the top and bottom of the structural column 132 so that the top plate 134 covers the top of the structural column 132 and the bottom plate 136 covers the bottom of the structural column 132. The structural column 132, for example, may be four sided, may be hollow, and may vary in wall thickness depending on building height and code requirements. The top plate 134 and the bottom plate 136 are shown in Figure 6 as being linear in the horizontal direction and are used where two walls are joined side-by-side so as to share a common linear horizontal axis. However, the top plate 134 and the bottom plate 136 may be "L" shaped plates when two walls are to be joined at a corner such that the horizontal axes of the two walls are perpendicular to one another.

One or more bolts 138 are suitably attached (such as by welding or casting) to the top plate 134. The bolts 138 extend away from the top plate 134 at right angles. Each end of the bottom plate 136 has a hole 140 therethrough. Accordingly, a first structural column 132 can be stacked vertically on a second structural column 132 such that the bolts 138 of the top plate 134 of the second structural column 132 pass through the holes 140 of the bottom plate 136 of the first structural column 132. Nuts may then be applied to the bolts 138 of the top plate of the second structural column 132 and tightened to fasten the first and second structural columns 132 vertically to one another.

The top and bottom plates 134 and 136 are slightly wider than the track 12 used for the horizontal truss panel 20/22/24 and vary in thickness depending on building height and code requirements. The through-bolting provided by the bolts 138 and holes 140 permit the structural columns 132 to be connected to one another vertically and to other assemblies within a building (roof, foundations, garages, etc.).

The structural columns 132 are connected to horizontal truss panels 20/22/24 by way of stud sections 142 of the stud 10. The stud sections 142 are welded or

otherwise suitably fastened to the top and bottom of the structural column 132. A stud section 144 is fastened by weld or suitable fastener at about the middle of the structural column 130 such that its web 14 faces
5 outwardly. This stud section 144 is a "hold-off" to keep the studs 36, 38, 88, and 90 of the horizontal truss panels from deflecting. Unification plates such as 154 may or may not be used at this location.

The material of the structural column 132, for
10 example, is cold rolled steel. The structural column 132 may be hollow and have a wall thickness that varies depending on application and code. The material of the plates 134 and 136 and for the truss hangars 144 and 146, for example, may be 18 - 14 gauge cold roll steel.

15 Figures 7 and 8 shows the manner of attaching a horizontal truss panel such as the horizontal truss panels 20, 22, and 24 to the structural column assembly 130. A unified horizontal truss panel is created when the structural column assembly 130 is attached to the
20 horizontal truss panel 20/22/24 using four truss hanger unification plates 150, which have a stud insertion projection for attachment of the trusses 106 discussed in further detail below, and two flat unification plates 154, all of which are attached by fasteners 34 to the

side stud 36 and 38 of the horizontal truss panel
20/22/24 and the stud sections 142. The stud sections
144 as shown in Figure 7 act to "hold-off" studs 36 and
38 so that these studs do not deflect through the space
5 between the side studs 36 and 38 and the structural
column 132. Unification plates such as 154 may or may
not be used at this location.

In a UTCS structure, a section or length of
wall is assembled by attaching a number (depending on
10 wall length) of horizontal truss panels together using
the structural column assemblies 130. The open
horizontal truss panels 24 are used as a wall section(s)
in buildings where there are larger openings like
windows, doors, and pass-throughs. The V-braced
15 horizontal truss panels 22/22 are used as wall section(s)
generally throughout the rest of the structure so as to
provide dense lateral support of the structure. Figure 9
shows a horizontal truss panel wall line having open and
V-braced horizontal truss panels 24 and 20/22 in a UTCS
20 wall line.

As indicated above, the truss 106 is attached
to the horizontal truss panel 20/22/24 by way of the
truss/stud hangars 116 and the fasteners 34 located at
the inboard studs 44 and 46 and the center stud 48. The

truss/stud hanger 116 is shown in Figure 11 and includes a stud insertion projection 152 to be received within the top stud 108 of the truss 106 as illustrated in Figure 5 and, when inverted 180 degrees as illustrated in Figures 5 and 8, within the bottom stud 110 of the truss 106. The truss/stud hanger 116 also includes L-shaped flanges 172 used to fasten the truss/stud hangers to the top track 26 and, inverted, to the horizontal bracing 30 and 32 of the horizontal truss panels.

10 The trusses 106 are connected to the horizontal truss panels 20/22/24 by inserting the end of the top stud 108 of the truss 106 into the insertion projection 152 and fastening by fasteners 34, and connecting by fasteners 34 the L-shaped flanges 172 to the web 14 and
15 flange 16 of the top track 26 and by connecting by fastener 34 a projection tab 176 of the truss hanger 116 to the top flange 16 of the stud 108. The bottom stud 110 of the truss 106 is connected by inverting the truss/stud hanger 116 by 180 degrees, inserting the end
20 of the bottom stud 110 of the truss 106 into the insertion projection 152 and fastening by fasteners 34, connecting by fasteners 34 the L-shaped flanges 172 to the web 14 of the tracks 30 and 32, and by connecting by

fastener 34 the projection tab 176 to the bottom flange
16 of the stud 110.

A truss 106 is also attached at each of the
structural columns 132 by way of an insertion projection
5 152 on the unification plate 150. The end of the top
stud 108 of the truss 106 is inserted over the insertion
projection 152 of the unification plate 150 and fastened
with fasteners 34 to the web 14 of the stud 108. The
projection tab 176 is fastened by a fastener to the top
10 flange 16 of the stud 108. The bottom stud 110 of the
truss 106 is connected by way of insertion of the end of
the stud 110 over the insertion projection 152 of an
unification plate 150 that is rotated 180 degrees.
Fasteners 34 are used to connect the insertion projection
15 152 to the web 14 of the stud 110. The projection tab
176 is attached by way of a fastener to the bottom flange
16 of the stud 110.

Figure 13 illustrates the trusses 106 connected
to horizontal truss panels 20/22/24.

20 Figure 14 illustrates the trusses 106 connected
to horizontal truss panels 20/22/24 forming a UTCS open
span assembly where the horizontal truss panels 20/22/24
are assembled with the trusses 106 to create a wall line.
The trusses 106 support a floor and ceiling assembly.

Attaching the trusses 106 to the horizontal truss panels in this manner incorporates the truss 106 into the horizontal truss panels 20/22/24, eliminating the "hinge-point" that exists where a wall assembly sits on a floor, or where a ceiling assembly sits on top of a wall. This connection unifies the trusses 106 and horizontal truss panels 20/22/24, in effect enabling the entire wall and floor system to act together as a "truss." This configuration facilitates the transfer of forces on the floor, ceiling, and horizontal truss panels 20/22/24 to their attached structural column assemblies 130. Accordingly, vertical and lateral forces are not transferred vertically horizontal truss panel to horizontal truss panel. When subflooring and drywall are incorporated into the building, the entire system acts as a "diaphragm."

Figure 15 illustrates a UTCS building section formed as an assembly of multiple floors of a UTCS structure. In a UTCS building or structure, the horizontal truss panels 20/22/24 are laid out such that the structural column assemblies 130 on one floor line up vertically with the structural column assemblies 130 on the floor below, and so on, down to a foundation.

Figure 16 shows this alignment of the structural column assemblies. Figure 16 also illustrates the density of the structural column assemblies 130 in a UTCS structure.

5 Figure 17 illustrates a three-dimensional view and a two-dimensional view of the floor-to-floor joints of this assembly. It shows that horizontal truss panels 20/22/24 do not contact or bear on each other, as is otherwise typical in "bearing wall" and steel and
10 concrete structures. The horizontal truss panels on one floor of a UTCS structure do not carry load from the floor above. This load is instead transferred to and carried by the structural column assemblies 130. Each "floor" or elevation of the structure dampens and
15 transfers its vertical live and dead load forces to the structural column assemblies 130, where they are dampened and transferred vertically to the foundation of the building.

The V-braced horizontal truss panels 20/22
20 dampen and transfer the lateral forces acting on the building to the redundant structural column assemblies 130 in the structure. This transfer of forces is illustrated in Figure 18. The blow up portion of Figure 18 also illustrates that the panels do not bear on each

other vertically and that the forces (arrows) are not transferred vertically from one panel to the other. Rather the vertical and lateral forces are transferred laterally to the structural column assemblies 130. This type of load transfer is facilitated by the unique design and assembly of the system. Both the horizontal truss panels 20/22/24 and the trusses 106 act as a unified truss system.

UTCS may employ horizontal truss panels of varying widths from 20' to 2', the most common being V-braced horizontal truss panels 20/22 measuring 8' and 4'. These panels lead to a significant redundancy of the structural column assemblies 130 within the structure. Each open horizontal truss panel 24 acts to support and mitigate only those vertical local forces proximate to their attached structural column assemblies 130. The V-braced horizontal truss panels 20/22 act to support vertical local forces as well as lateral forces acting on the structure. Because of the unique manner in which the horizontal truss panels 20/22/24 transfer vertical and lateral forces and the redundancy of the structural column assemblies 130 in the system, there is no need to configure panels differently from floor-to-floor. Only the width and gauge of the tracks 12, the studs 10, and

V-brace vary, depending on building height and code requirements.

Interior non-structural partition walls that separate spaces within a UTCS building are constructed
5 from light gauge steel (typically 24 - 28 gauge) and are typical in Type I and Type II steel frame construction.

UTCS is extremely efficient in managing vertical and lateral forces on a building. With UTCS the need to build a bearing wall structure or heavy
10 structural core is eliminated, vastly reducing costs over traditional construction practices. UTCS saves time as well because the structure of a building is erected from a limited number of pre-assembled panels. This also dramatically reduces the cost of engineering the
15 structure of buildings.

UTCS is unique and innovative. It can be built on nearly any foundation system including slabs, structured parking, retail and commercial buildings. UTCS employs a framing technology that is based on a
20 system-built, panelized approach to construction. UTCS uses panelized building technology and innovative engineering to significantly reduce the cost of design, material, and erection of a building. UTCS technology

and engineering is a new structural system and method of assembling single and multistory buildings.

Certain modifications of the present invention have been discussed above. For example, although the present invention is particularly useful for constructing and assembling buildings without relying on concrete and/or structural steel framing, heavy steel let-in bracing, and heavy steel and/or concrete panels, it can also be applied to buildings having concrete and/or structural steel framing, heavy steel let-in bracing, and heavy steel and/or concrete panels. Other modifications will occur to those practicing in the art of the present invention. Accordingly, the description of the present invention is to be construed as illustrative only and is for the purpose of teaching those skilled in the art the best mode of carrying out the invention. The details may be varied substantially without departing from the spirit of the invention, and the exclusive use of all modifications which are within the scope of the appended claims is reserved.

We claim:

1. A building section comprising:
 - a first structural column having a top
5 connector and a bottom connector;
 - a second structural column having a top
connector and a bottom connector, wherein the top
connector of the first structural column is connected to
the bottom connector of the second structural column so
10 that the first and second structural columns align
vertically;
 - a first wall panel attached to the first
structural column; and,
 - a second wall panel attached to the second
15 structural column such that the first and second wall
panels align vertically and such that a clearance exists
between the first and second wall panels so that load is
transferred through the first and second structural
columns rather than vertically between the first and
20 second wall panels.

2. The building section of claim 1 wherein
the bottom connector of each of the first and second
structural columns comprises a bottom connector plate

having at least one hole extending therethrough, wherein the top connector of each of the first and second structural columns comprises a top connector plate having at least one bolt or screw projecting upwardly therefrom, and wherein hole of the bottom connector plate of the second structural column receives the bolt or screw of the top connector plate of the first structural column for fastening the first and second structural columns together.

10

3. The building section of claim 2 further comprising first and second stud sections and first and second attachment plates, wherein the first stud section is attached to the first structural column, wherein the second stud section is attached to the second structural column, wherein the first attachment plate fastens the side of the first wall panel to the first stud section, and wherein the second attachment plate fastens the side of the second wall panel to the second stud section.

20

4. The building section of claim 3 wherein each of the first and second stud sections comprises a web, first and second flanges, and first and second lips, wherein the first and second flanges extend in the same

direction at substantially right angles from opposing sides of the web, and wherein the first and second lips extend inwardly from ends of the first and second flanges such that the first and second lips parallel the web.

5

5. The building section of claim 3 further comprising:

a third wall panel attached to the first structural column;

10

a fourth wall panel attached to the second structural column such that the third and fourth wall panels align vertically and such that a clearance exists between the third and fourth wall panels so that load is transferred through the first and second structural

15

columns rather than between the third and fourth wall panels;

and third and fourth stud sections, wherein the third stud section is attached to the first structural column, wherein the fourth stud section is attached to

20

the second structural column, wherein the first attachment plate fastens the side of the third wall panel to the first stud section, and wherein the second attachment plate fastens the side of the fourth wall panel to the second stud section.

6. A truss panel for a building comprising:
first, second, third, and fourth horizontal
elongated members;
5 first and second vertical elongated members
fastened to the first, second, third, and fourth
horizontal elongated members such that the first and
fourth horizontal elongated members form respectively a
top and a bottom of the truss panel, such that the first
10 and second vertical elongated members form respective
sides of the truss panel, such that first and second
horizontal elongated members define a truss attachment
area of the truss panel, and such that the second and
third horizontal elongated members form a double
15 horizontal brace of the truss panel; and,
an angled webbing fastened to the first and
second horizontal elongated members between the first and
second vertical elongate members to create a panel truss
in the truss attachment area.

20

7. The truss panel of claim 6 wherein the
first, second, third, and fourth elongated members
comprises corresponding first, second, third, and fourth
tracks, wherein each of first, second, third, and fourth

tracks comprises a track web, first and second track flanges, and first and second track lips, wherein the first and second track flanges extend in the same direction at substantially right angles from opposing sides of the track web, and wherein the first and second track lips extend inwardly from ends of the first and second track flanges such that the first and second track lips parallel the track web;

and further wherein the first and second vertical elongated members comprise corresponding first and second studs, wherein each of first and second studs comprises a stud web, first and second stud flanges, and first and second stud lips, wherein the first and second stud flanges extend in the same direction at substantially right angles from opposing sides of the stud web, wherein the first and second stud lips extend inwardly from ends of the first and second stud flanges such that the first and second stud lips parallel the stud web, and wherein the track web is wider than the stud web such the first and second studs can be fitted within the first, second, third, and fourth tracks.

8. The truss panel of claim 7 wherein each of the first, second, third, and fourth tracks and each of

the first and second studs comprises light gauge steel of between 18 and 14 gauge inclusive.

9. The truss panel of claim 6 wherein the
5 wall further comprises third, fourth, and fifth vertical elongated members fastened to the first, second, third, and fourth horizontal elongated members such that fourth vertical elongated member is substantially centered between the first and second vertical elongated members,
10 such that third vertical elongated member is between the first and fourth vertical elongated members, and such that the fifth vertical elongated member is between the fourth and second vertical elongated members.

15 10. The truss panel of claim 9 wherein the first, second, third, and fourth elongated members comprises corresponding first, second, third, and fourth tracks, wherein each of first, second, third, and fourth tracks comprises a track web, first and second track
20 flanges, and first and second track lips, wherein the first and second track flanges extend in the same direction at substantially right angles from opposing sides of the track web, and wherein the first and second track lips extend inwardly from ends of the first and

second track flanges such that the first and second track lips parallel the track web;

and further wherein the first, second, third, fourth, and fifth vertical elongated members comprise corresponding first, second, third, fourth, and fifth studs, wherein each of first, second, third, fourth, and fifth studs comprises a stud web, first and second stud flanges, and first and second stud lips, wherein the first and second stud flanges extend in the same direction at substantially right angles from opposing sides of the stud web, wherein the first and second stud lips extend inwardly from ends of the first and second stud flanges such that the first and second stud lips parallel the stud web, and wherein the track web is wider than the stud web such the first, second, third, fourth, and fifth studs can be fitted within the first, second, third, and fourth tracks.

11. The truss panel of claim 10 wherein each of the first, second, third, and fourth tracks and each of the first, second, third, fourth, and fifth studs comprises light gauge steel of between 18 and 14 gauge inclusive.

12. The truss panel of claim 9 further comprising:

a first brace member fastened to first and third vertical elongated members and to the fourth horizontal elongated member; and,

a second brace member fastened to second and fifth vertical elongated members and to the fourth horizontal elongated member, wherein the first and second brace member form a V-brace for the truss panel.

10

13. The truss panel of claim 12 further comprising a third brace member between the third and fifth vertical elongated members and fastened to the third, fourth, and fifth vertical elongated members.

15

14. The truss panel of claim 6 further comprising:

a first truss hangar fastened to the first horizontal elongated member, wherein the first truss hangar is arranged to fasten to a ceiling or floor truss; and,

a second truss hangar fastened to at least one of the third and second horizontal elongated member,

wherein the second truss hangar is arranged to fasten to the ceiling or floor truss.

15 15. The truss panel of claim 14 wherein the ceiling or floor truss comprises:
 a first horizontal truss member fastened to the first truss hangar;
 a second horizontal truss member fastened to the second truss hangar; and,
10 a plurality of angled members fastened to the first and horizontal truss members.

 16. The truss panel of claim 15 wherein each of the first and horizontal members and the angled
15 members comprises a stud having a stud web, first and second stud flanges, and first and second stud lips, wherein the first and second stud flanges extend in the same direction at substantially right angles from
 opposing sides of the stud web, and wherein the first and
20 second stud lips extend inwardly from ends of the first and second stud flanges such that the first and second stud lips parallel the stud web.

17. The truss panel of claim 6 wherein each of the first, second, third, and fourth horizontal elongated members and each of the first and second vertical elongated member comprises light gauge steel of between
5 18 and 14 gauge inclusive.

18. A panel for a building comprising:
first, second, third, and fourth horizontal elongated members;
10 first and second vertical elongated members fastened to the first, second, third, and fourth horizontal elongated members such that the first and fourth horizontal elongated members form respectively a top and a bottom of the panel, such that the first and
15 second vertical elongated members form respective sides of the panel, and such that the second and third horizontal elongated members form a double horizontal brace of the panel; and,

wherein at least one of the horizontal and
20 vertical elongated members comprises a stud, wherein at least another one of the horizontal and vertical elongated members comprises a track, wherein the track comprises a track web and first and second track flanges, wherein the first and second track flanges extend in the

same direction at substantially right angles from
opposing sides of the track web, wherein the stud
comprises a stud web and first and second stud flanges,
wherein the first and second stud flanges extend in the
5 same direction at substantially right angles from
opposing sides of the stud web, and wherein the track web
is wider than the stud web such the stud can be fitted
within the track.

10 19. The panel of claim 18 wherein the track
further comprises first and second track lips, wherein
the first and second track lips extend inwardly from ends
of the first and second track flanges such that the first
and second track lips parallel the track web, wherein the
15 stud further comprises first and second stud lips, and
wherein the first and second stud lips extend inwardly
from ends of the first and second stud flanges such that
the first and second stud lips parallel the stud web.

20 20. The panel of claim 18 wherein each of the
track and the stud comprises light gauge steel of between
18 and 14 gauge inclusive.

21. The panel of claim 18 wherein the wall further comprises third, fourth, and fifth vertical elongated members fastened to the first, second, third, and fourth horizontal elongated members such that fourth
5 vertical elongated member is substantially centered between the first and second vertical elongated members, such that third vertical elongated member is between the first and fourth vertical elongated members, and such that the fifth vertical elongated member is between the
10 fourth and second vertical elongated members.

22. The panel of claim 21 further comprising:
a first brace member fastened to first and third vertical elongated members and to the fourth
15 horizontal elongated member; and,
a second brace member fastened to second and fifth vertical elongated members and to the fourth horizontal elongated member, wherein the first and second brace member form a V-brace for the truss panel.

20

23. The panel of claim 22 further comprising a third brace member between the third and fifth vertical elongated members and fastened to the third, fourth, and fifth vertical elongated members.

24. A method of constructing a building comprising:

fastening a first wall panel to a first structural column;

5 fastening a second structural column vertically to the first structural column; and,

fastening a second wall panel to the second structural column so that the second wall panel is

10 vertically above the first wall panel, so that a clearance is between the first and second wall panels, and so that vertical and lateral forces on the wall panels are transferred from the first and second wall panels to the first and second structural columns and not

15 vertically between the first and second wall panels.

25. The method of claim 24 further comprising:

fastening a third wall panel to the first structural column; and,

20 fastening a fourth wall panel to the second structural column so that the fourth wall panel is vertically above the third wall panel, so that a clearance is between the third and fourth wall panels, and so that vertical and lateral forces on the wall

panels are transferred from the third and fourth wall panels to the first and second structural columns and not between the third and fourth wall panels.

5 26. The method of claim 24 further comprising:
fastening a first truss to the first wall panel
so that the first truss supports a ceiling of a first
space defined at least partially by the first wall panel
and a floor of a second space defined at least partially
10 by the second wall panel; and,

fastening a second truss to the second wall
panel so that the second truss supports a ceiling of the
second space and a floor of a third space above the
second space.

15

27. The method of claim 24 further comprising:
fastening a third structural column vertically
to the second structural column;
fastening a third wall panel to the third
20 structural column vertically above the second wall panel;
fastening a fourth structural column vertically
to the third structural column;

fastening a fourth wall panel to the fourth
structural column vertically above the third wall panel;

fastening a fifth structural column vertically to the fourth structural column;

fastening a fifth wall panel to the fifth structural column vertically above the fourth wall panel;

5 fastening a sixth structural column vertically to the fifth structural column; and,

fastening a sixth wall panel to the sixth structural column vertically above the fifth wall panel;

10 wherein vertical and lateral forces on the first, second, third, fourth, fifth, and sixth wall panels are transferred from the first, second, third, fourth, fifth, and sixth wall panels to the first, second, third, fourth, fifth, and sixth structural columns and not between the first, second, third, fourth, 15 fifth, and sixth wall panels.

28. The method of claim 27 wherein all of the wall panels are constructed from studs comprising light gauge steel of between 18 and 14 gauge inclusive.

20

29. The method of claim 28 wherein each of the studs comprises a stud web, first and second stud flanges, and first and second stud lips, wherein the first and second stud flanges extend in the same

direction at substantially right angles from opposing sides of the stud web, wherein the first and second stud lips extend inwardly from ends of the first and second stud flanges such that the first and second stud lips
5 parallel the stud web.

30. A method of constructing a building comprising:

fastening a first unified wall panel to a
10 second unified wall panel, wherein the first unified wall panel comprises a first wall panel and a first structural column, and wherein the second unified wall panel comprises a second wall panel and a second structural column;

15 fastening a third unified wall panel to a fourth unified wall panel, wherein the third unified wall panel comprises a third wall panel and a third structural column, and wherein the fourth unified wall panel comprises a fourth wall panel and a fourth structural
20 column;

fastening the third structural column vertically to the first structural column so that the third wall panel is vertically above the first wall

panel, and so that a clearance is between the first and third wall panels; and,

fastening the fourth structural column vertically to the second structural column so that the fourth wall panel is vertically above the second wall panel, so that a clearance is between the second and third wall panels, and so that vertical and lateral forces on the wall panels are transferred from the wall panels to the structural columns and not vertically between the wall panels.

31. The method of claim 30 further comprising:

fastening first trusses to the first and second wall panels so that the first trusses support a ceiling of a first space defined at least partially by the first and second wall panels and a floor of a second space defined at least partially by the third and fourth wall panels; and,

fastening second trusses to the third and fourth wall panels so that the second trusses support a ceiling of the second space and a floor of a third space above the second space.

32. The method of claim 30 wherein all of the wall panels are constructed from studs comprising light gauge steel of between 18 and 14 gauge inclusive.

5 33. The method of claim 32 wherein each of the studs comprises a stud web, first and second stud flanges, and first and second stud lips, wherein the first and second stud flanges extend in the same direction at substantially right angles from opposing
10 sides of the stud web, wherein the first and second stud lips extend inwardly from ends of the first and second stud flanges such that the first and second stud lips parallel the stud web.