



US00RE37378B1

(19) **United States**
(12) **Reissued Patent**
Nagano

(10) **Patent Number:** US RE37,378 E
(45) **Date of Reissued Patent:** Sep. 18, 2001

(54) **READER WITH HIGH-RESOLUTION MODE AND HIGH-SPEED MODE**

5,264,945 * 11/1993 Kannegundla et al. 358/482

FOREIGN PATENT DOCUMENTS

(75) Inventor: **Fumikazu Nagano**, Yamato-Koriyama (JP)

0613 289A1 * 2/1994 (EP) H04N/1/028
5-48460 * 2/1993 (JP) H03M/1/12
6-253091 * 9/1994 (JP) H04N/1/40

(73) Assignee: **Sharp Kabushiki Kaisha**, Osaka (JP)

OTHER PUBLICATIONS

(21) Appl. No.: **09/136,597**
(22) Filed: **Aug. 19, 1998**

I. Tokuji, et al., "Automatic Focus Detector", *Patent Abstracts of Japan*, vol. 11, No. 391, (1987) p. 649.*

* cited by examiner

Related U.S. Patent Documents

Reissue of:

(64) Patent No.: **5,687,003**
Issued: **Nov. 11, 1997**
Appl. No.: **08/543,192**
Filed: **Oct. 13, 1995**

Primary Examiner—Scott Rogers

(74) *Attorney, Agent, or Firm*—Dike, Bronstein, Roberts & Cushman, LLP; David G. Conlin

(57) **ABSTRACT**

(30) **Foreign Application Priority Data**

Nov. 25, 1994 (JP) 6-291660

(51) **Int. Cl.**⁷ **H04N 1/40**; H04N 1/047; H04N 1/028

(52) **U.S. Cl.** **358/445**; 358/474; 358/483

(58) **Field of Search** 358/445, 471, 358/474, 482, 483, 494; 341/156, 155; 250/208.1

A reader having a high-resolution mode and a high-speed mode is disclosed. The reader comprises a CCD sensor, a buffer, a first AD converter, a second AD converter, a data selector and a control circuit. The input of the buffer is connected to the CCD sensor through a capacitor and a 5 V power source through an analog switch, and an output of the buffer is connected to the first AD converter for the high-resolution mode and the second AD converter for the high-speed mode in parallel. The data selector for selecting an output from the first AD converter or the second AD converter and sending it out to the control circuit is connected to the outputs of the first AD converter and the second AD converter.

(56) **References Cited**

U.S. PATENT DOCUMENTS

4,733,217 * 3/1988 Dingwall 341/156
5,053,771 * 10/1991 McDermott 341/156

7 Claims, 9 Drawing Sheets

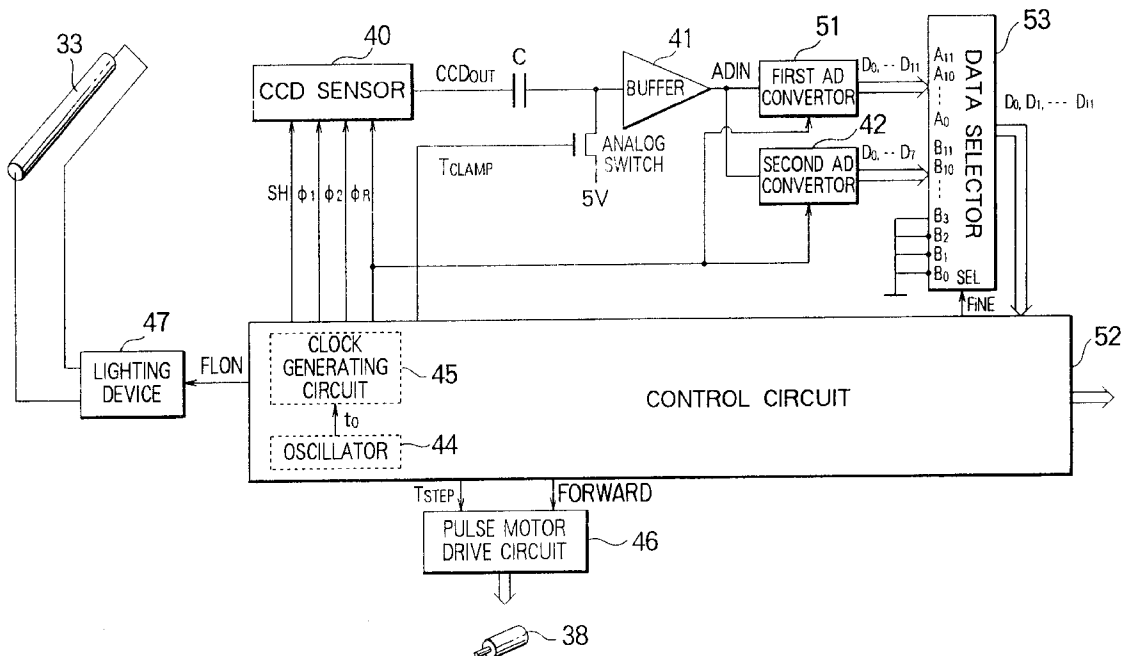

FIG. 1

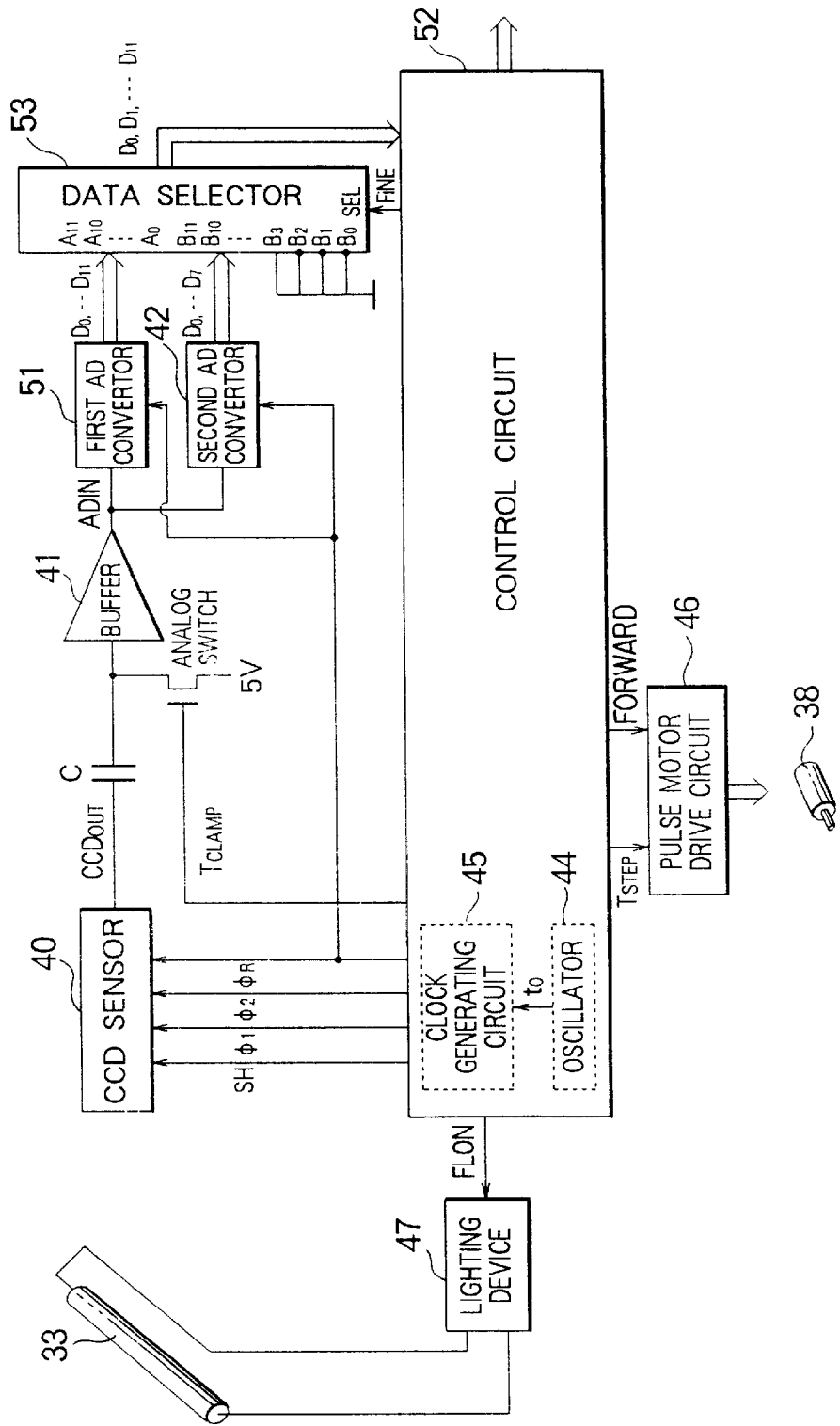

FIG. 2
(PRIOR ART)

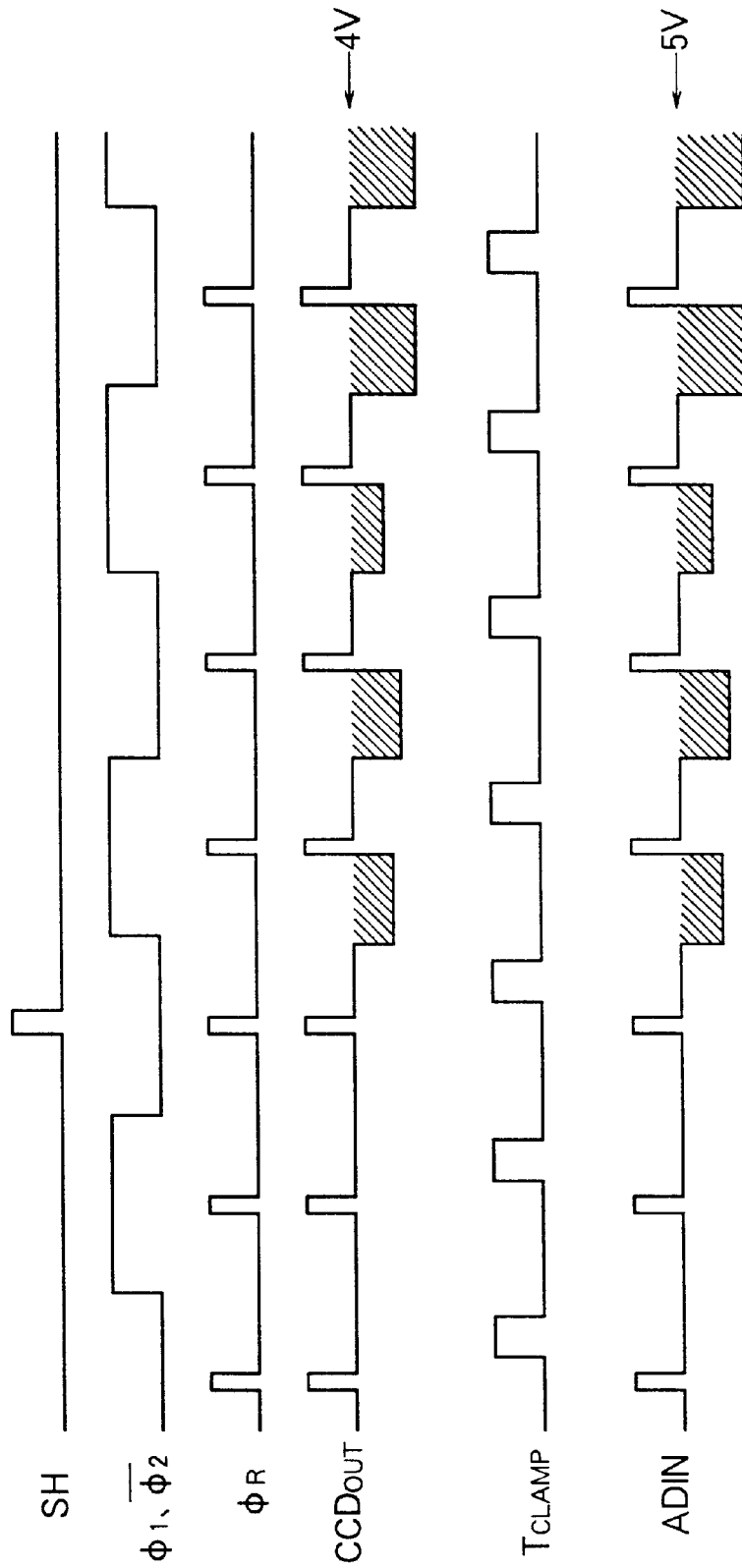

FIG. 3
(PRIOR ART)

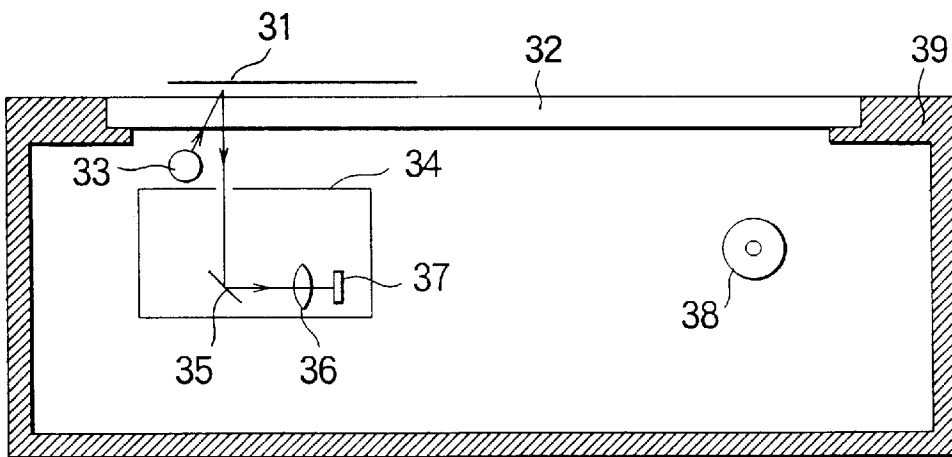

FIG. 4
(PRIOR ART)

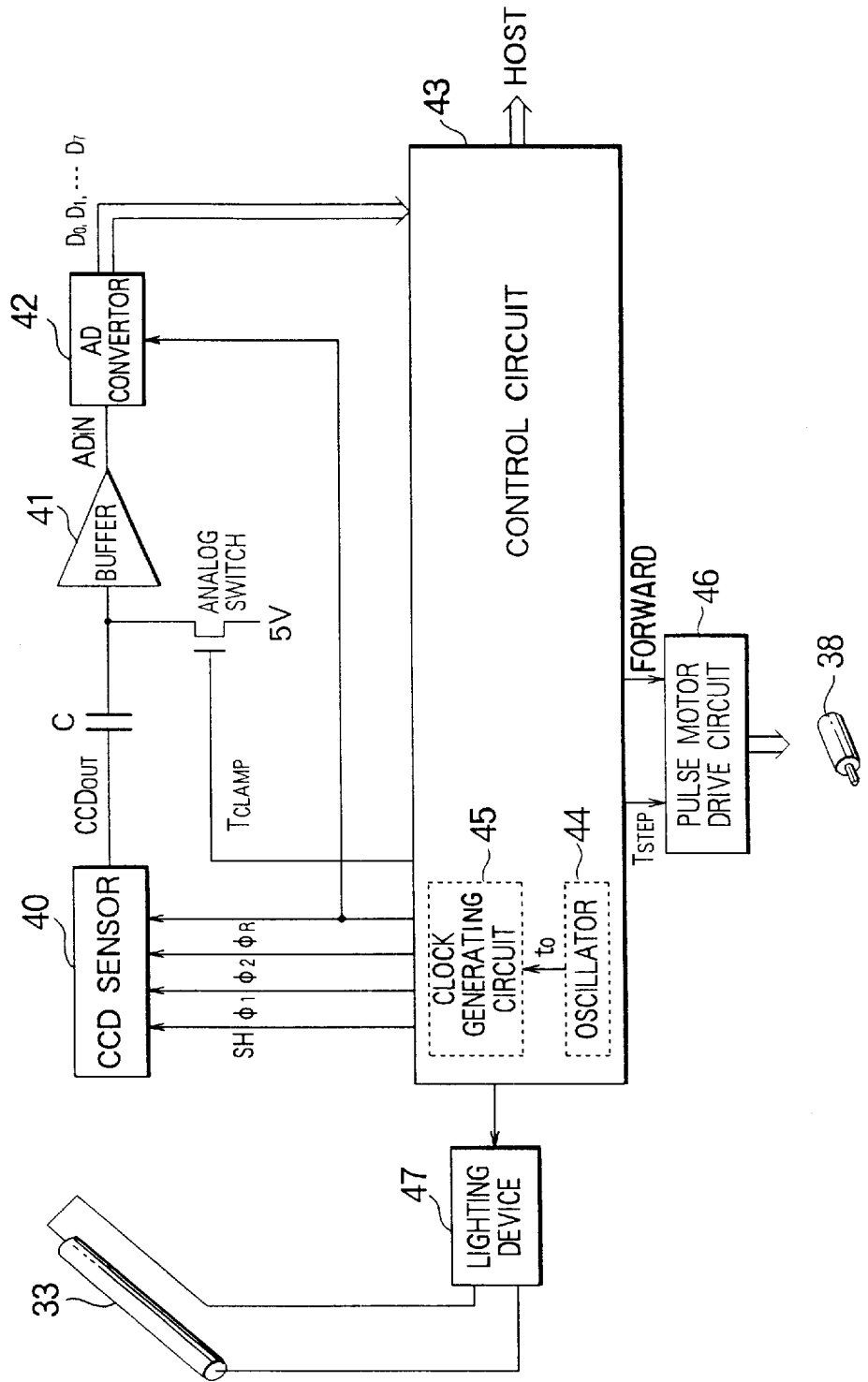

FIG. 5
(PRIOR ART)

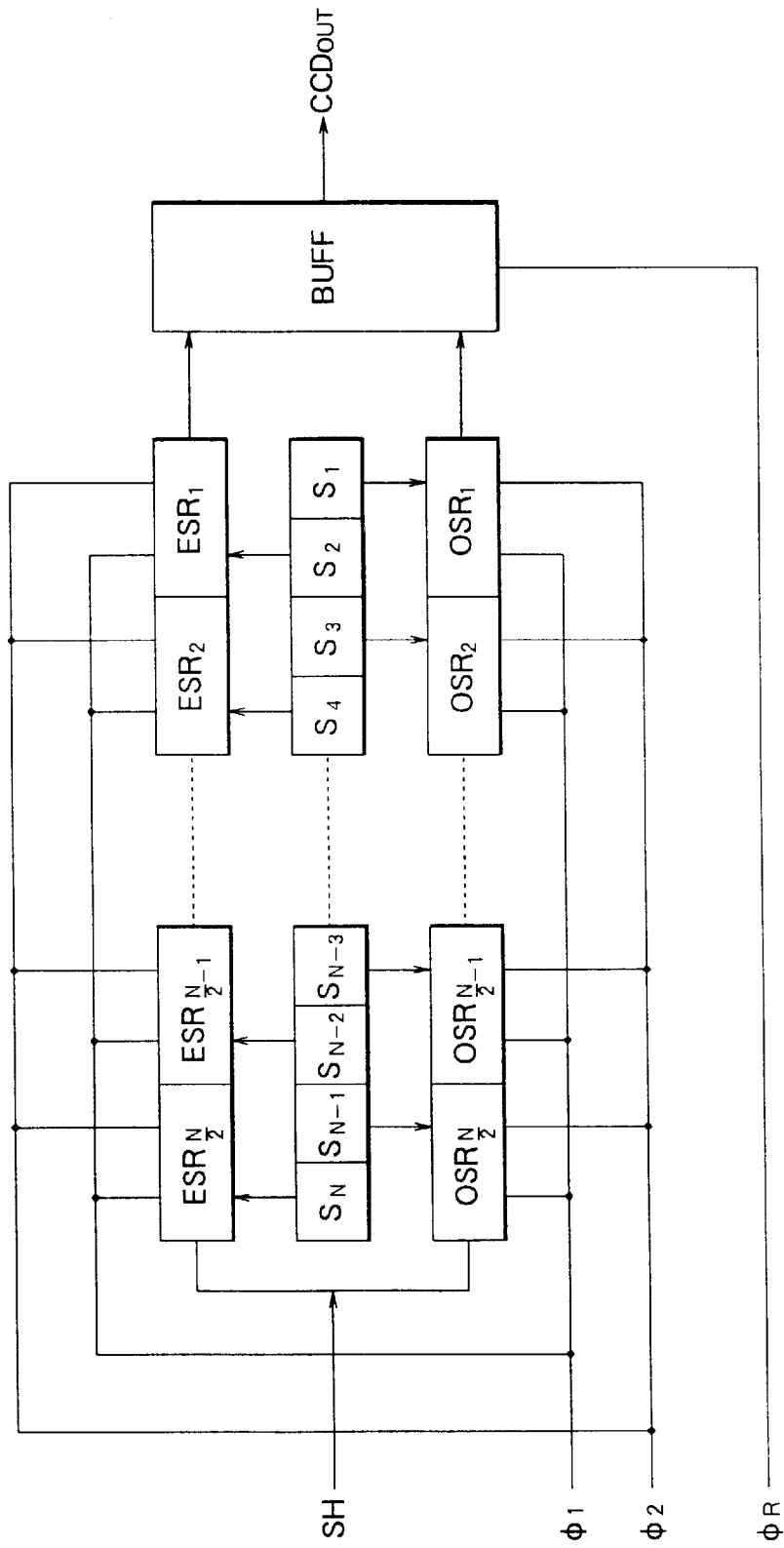
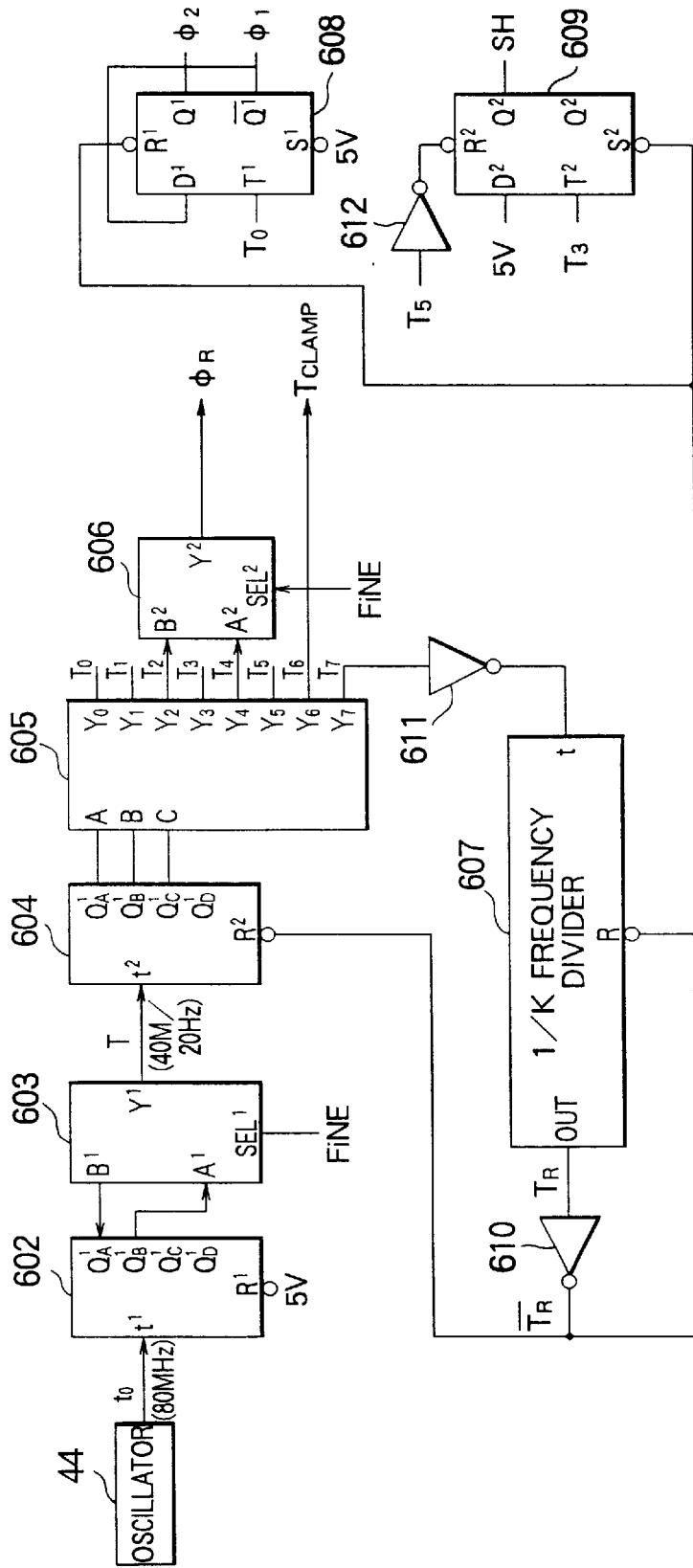
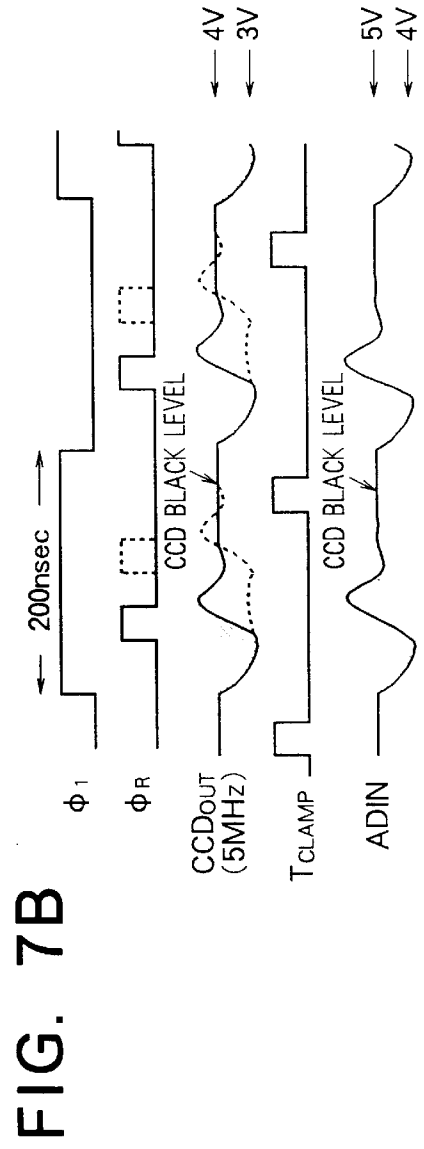
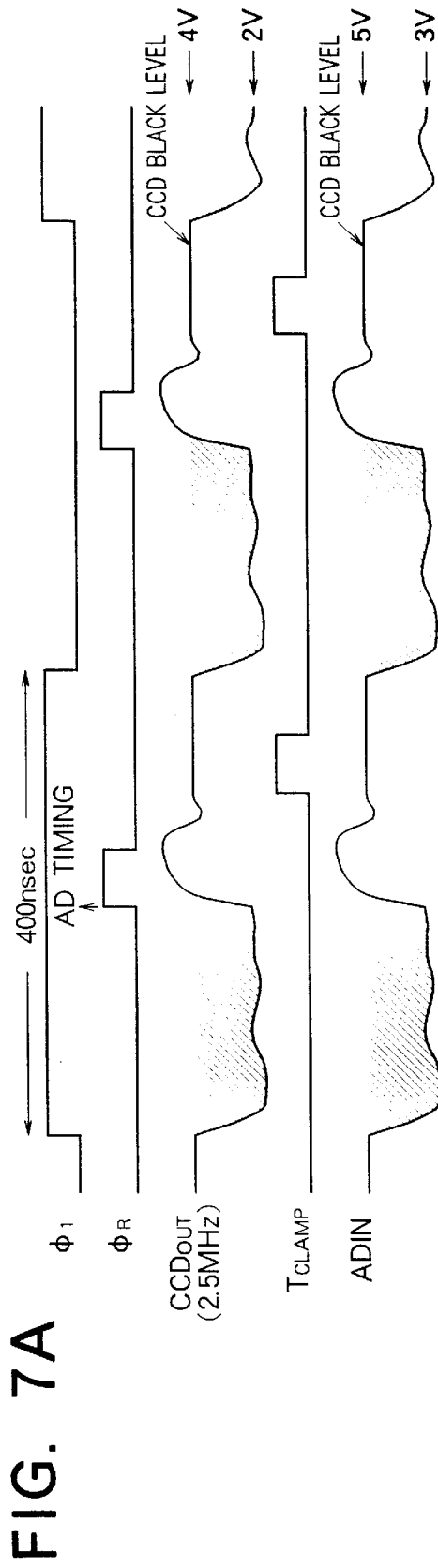

FIG. 6





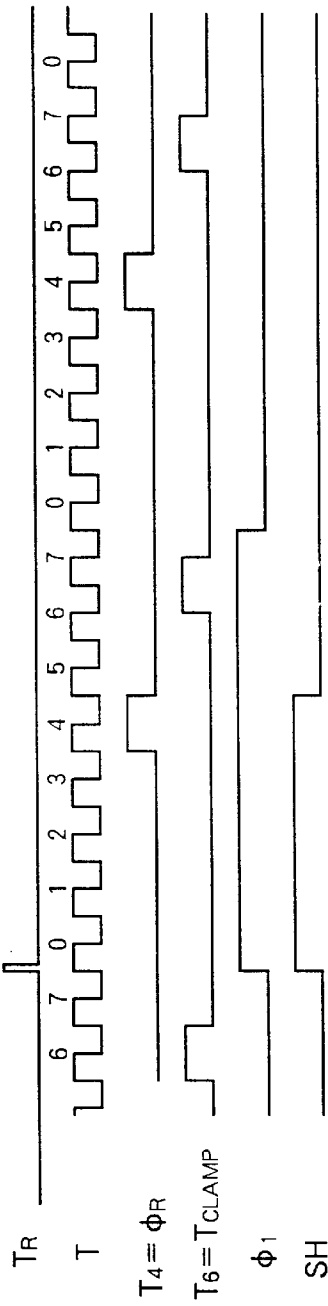

FIG. 8A

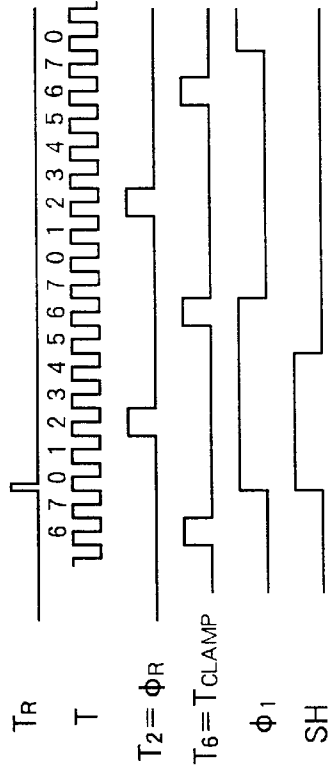
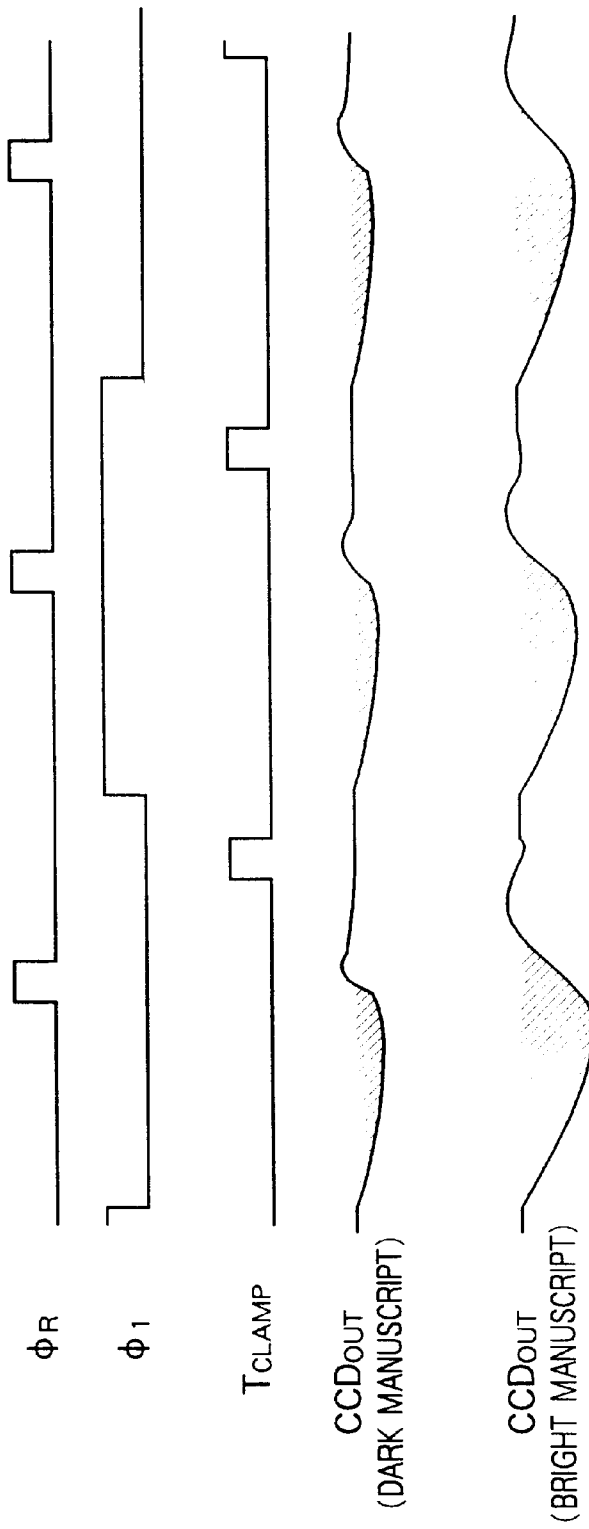

FIG. 8B

FIG. 9



**READER WITH HIGH-RESOLUTION MODE
AND HIGH-SPEED MODE**

Matter enclosed in heavy brackets [] appears in the original patent but forms no part of this reissue specification; matter printed in italics indicates the additions made by reissue.

BACKGROUND OF THE INVENTION

1. Field of the Invention

The present invention relates to a reader and more particularly, to a reader having a high-resolution mode and a high-speed mode using a CCD sensor.

2. Description of the Related Art

Recently, as means for inputting a document and drawing data or input means for digital copiers and facsimile, there has been widely used a reader using a CCD sensor.

A CCD sensor used in this reader will be described by referring to FIG. 5.

Analog shift registers arranged in odd rows and analog shift register arranged in even rows are finally combined into an output signal CCD_{OUT} through buffers. Symbols S_1, S_2, \dots, S_N denote light receiving means. $OSR_1, OSR_2, \dots, OSR_{N/2}$ denote odd-row shift registers for shifting out the analog outputs of light receiving means on the odd side (light receiving means arranged in odd rows) an $ESR_1, ESR_2, \dots, ESR_{N/2}$ denote even-row shift registers for shifting out the analog outputs of light receiving means on the even side (light receiving means arranged in even rows). Furthermore, symbol SH denote a start pulse for the shift operation of the shift registers, symbols ϕ_1 and ϕ_2 denote transfer pulses, and symbol ϕ_R denotes a reset pulse.

Then, referring to FIG. 3, the positional relationship between a line-shaped fluorescent lamp 33 and a CCD sensor 37 in a reader will be described.

A manuscript 31 is laid on a glass table 32. In FIG. 3, the glass table 32 and the manuscript 31 are spaced from each other but actually are closely in contact with each other. The manuscript 31 is illuminated through the glass table 32 with a ray of light emitted from the fluorescent lamp 33 with the longitudinal direction placed vertically to the surface of a paper. The ray of light reflected from the manuscript passes again through the glass table and is reflected from the mirror 35. The ray of light reflected from the mirror 35 is focussed at a lens 36 and illuminated to the light receiving surface of the CCD sensor 37. Numeral 34 denotes an optical unit including the mirror 35, the lens 36 and the CCD sensor 37, while numerals 38 and 39 denote a pulse motor and a cabinet, respectively.

As shown in FIG. 4, a conventional reader incorporates a CCD sensor 40 for converting a received light into an electrical signal and the CCD sensor 40 is connected via a capacitor C to an input of a buffer 41. The input of the buffer 41 is connected to a 5 V electric power source via an analog switch. The output of the buffer 41 is connected to the input of an AD converter 42. The outputs D_0-D_7 of the AD converter 42 are connected to a control circuit 43. The output FLON of the control circuit 43 is connected to the input of a lighting device 48. The output of the lighting device 48 is connected to the input of a fluorescent lamp 33. When the FLON turns to "1", the fluorescent lamp 33 turns on. The outputs T_{STEP} and FORWARD of the control circuit 43 are connected to the input of a pulse motor drive circuit 46. The input of the pulse motor drive circuit 46 is connected to the input of a pulse motor 38. If "FORWARD" is "1" the pulse

motor 38 is rotated by the pulse motor drive circuit 46 so as to forward the optical unit 34 and the fluorescent lamp 33 by one step, when the pulse motor receives one time of T_{STEP} pulse. Similarly, if "FORWARD" IS "0", the pulse motor 38 is rotated so as to reverse the optical unit 34 and the fluorescent lamp 33, when the pulse motor receives the T_{STEP} pulse.

The control circuit 43 comprises an oscillator 44 and a clock generating circuit 45 connected thereto. A basic clock t_0 is oscillated by the oscillator 44 and divided in frequency by the clock generating circuit 45 to generate various control pulses SH, ϕ_1, ϕ_2, ϕ_R and T_{CLAMP} . Control pulses SH, ϕ_1, ϕ_2 and ϕ_R are supplied to the CCD sensor 40 and a control pulse T_{CLAMP} is supplied to the analog switch.

FIG. 2 shows drive signals SH, ϕ_1, ϕ_2, ϕ_R to the CCD sensor 40, a CCD output CCD_{out} a clamp signal T_{CLAMP} for clamping the CCD_{out} a timing of ADIN which is an input signal to the AD converter 42.

Then, the operation of an analog switch and C shown in FIG. 4 will be described.

Ordinarily, the CCD output CCD_{out} is not defined as a DC signal, for example, outputted in the negative direction from a standard voltage of 4 V, as shown in FIG. 2. This standard varies between 3.5 V and 4.5 V according to each CCD sensors. However, since the AD converter will digitalize an analog voltage of 5 V or less, it is necessary to shift the DC level in such a manner that a value of output voltage from the capacitor C and the analog switch may be 5 V or less. Thus, the capacitor C comes to be always charged to 1 V.

Here, the CCD_{out} has a load of long transmission path and is usually amplified in use, and accordingly noises in the relevant amplifier are randomly superimposed onto the CCD_{out} . For example, the DC level of the CCD_{out} is normally 4 V but is assumed to become 3.8 V due to the random noises mentioned above. At this time, C has to be rapidly charged to 1.2 V that is 0.2 V higher than a normal 1 V. Thus, setting the clamp time to $t=300$ nsec and the ON resistance of the analog switch to 50 Ω , The capacitance C becomes as follows:

$$C\Omega R \ll t$$

$$C \leq 300 \text{ nsec} / 50 \Omega = 6000 \text{ pF.}$$

In conventional scanners, a value of 1000 pF or less is selected. By secure clamping of the DC level of each individual CCD signal outputs in this way, an image with reduced random noise is obtained as a reader.

On the other hand, Japanese Patent Application Laying Open No. 5-48460 discloses a three-dimensional integrated circuit comprising an AD converter for executing a digital to analog conversion with high-speed and high-resolution.

However, in a reader described by referring to FIGS. 2 to 5, through an image with reduced random noise is obtained as a reader, by secure clamping of the DC level of each individual CCD signal outputs, the stable period of the CCD_{out} is further needed before and after the clamp signal T_{CLAMP} , thereby the operating speed becomes slower. In addition, a three-dimensional integrated circuit disclosed in Japanese Patent Application Laying Open No. 5-48460 comprises a complicated circuit and becomes slower in the rate of AD conversion than ordinary AD converter.

In order to solve these problems, as shown in Japanese Patent application Laying Open No. 6-253091, the applicant of the present invention proposes a reader comprising: a CCD sensor for individually outputting an output of the light receiving section arranged in odd rows and an output of that arranged in even rows; a first AD converter corresponding to either one of the outputs of odd rows or even rows; a second

AD convertor corresponding to the other of the outputs of odd rows or even rows; and means for supplying the other of the outputs of odd rows or even rows to the first AD convertor when a high-resolution mode is selected.

However, in the reader of Japanese Patent Application Laying Open No. 6-253091, the quality in the high-resolution mode is equal to the quality of ordinary reader though the device becomes complicated.

SUMMARY OF THE INVENTION

It is therefore an object of the present invention to provide a reader capable of selecting either the high-resolution mode or the high-speed mode and further enabling the read to be performed at higher speed in the high-speed mode and/or at higher quality in the high-resolution mode.

According to the present invention, the above object is achieved by a reader having a high-resolution mode and a high-speed mode comprising: a CCD sensor for converting a received light into an electrical signal; a first AD convertor for converting the output signal of said CCD sensor into a digital signal; a second AD converter for converting the output signal of said CCD sensor into a digital signal with fewer bits than those of said first AD convertor; and means for selecting one of output signals of said first and said second AD convertors.

Preferably, the first AD convertor performs an analog to digital conversion for a longer period than that of said second AD convertor.

More preferably, the first and second AD convertors are arranged to convert the output of the CCD sensor within a predetermined course of time during the respective reading period, and the ratio of said predetermined course of time to the reading period in said second AD convertor is shorter than that of said predetermined course of time to the reading period in said first AD convertor to secure a period for stabilizing the output signal level of the CCD sensor.

In the reader according to the present invention, a ray of light reflected from a manuscript is received by the CCD sensor for converting the light into an electric signal, and an output of the CCD sensor is converted into a digital signal with a high-quality and accuracy by the first AD convertor when a high-resolution mode is selected. On the other hand, when a high-speed read is selected, a ray of light reflected from a manuscript is received by the CCD sensor for converting the light into an electric signal, and an output of the CCD sensor is converted into a digital signal by the second AD convertor in fewer bits than those of said first AD convertor, thereby enabling the read to be performed at higher speed in the high-speed mode and at higher quality in the high-resolution mode.

Accordingly, it is possible to obtain desired resolution corresponding to various images in a single scanner by switching the AD convertors by the output selection means.

Preferably, an output of the CCD sensor is converted into a digital signal by the first AD convertor for a longer period than that of said second AD convertor, thereby enabling the read to be performed at higher quality in the high-resolution mode.

More preferably, the ratio of the course of time taken till an output signal has been converted to the reading period of the CCD sensor in said second AD convertor is shorter than that of the course of time taken till an output signal has been converted to the reading period of the CCD sensor in said first AD convertor, thereby securing a period for stabilizing the DC level in output signals of the CCD sensor so that output signals of the CCD sensor can sufficiently be stabi-

lized even at the high-speed mode. Accordingly, it is possible to perform a high-speed image reading process in the high-speed mode and obtaining a stable back level for enabling a stable output image to be obtained.

Further objects and advantages of the present invention will be apparent from the following description of the preferred embodiment of the invention as illustrated in the accompanying drawings.

BRIEF DESCRIPTION OF THE DRAWINGS

FIG. 1 is a block diagram showing the constitution of a reader according to one embodiment of the present invention;

FIG. 2 is the timing chart of a conventional reader;

FIG. 3 is a schematic drawing of a reader;

FIG. 4 is a block diagram showing the constitution of a conventional reader;

FIG. 5 is a block diagram of a CCD used in a conventional reader;

FIG. 6 is a circuit diagram showing a clock generating circuit in the embodiment of FIG. 1;

FIG. 7A is a first timing chart showing the operation of the embodiment of FIG. 1 in the high-resolution mode;

FIG. 7B is a first timing chart showing the operation of the embodiment of FIG. 1 in the high-speed mode;

FIG. 8A is a second timing chart showing the operation of the embodiment of FIG. 1 in the high-resolution mode;

FIG. 8B is a second timing chart showing the operation of the embodiment of FIG. 1 in the high-speed mode; and

FIG. 9 is a timing chart showing the operation of the embodiment of FIG. 1 in different brightness cases of a manuscript.

DESCRIPTION OF THE PREFERRED EMBODIMENT

Next, the embodiment of the present invention will be described by referring to the drawings.

As shown in FIG. 1, a reader according to the present invention comprises a fluorescent lamp 33 for illuminating light onto a manuscript, a control circuit 52 for controlling each section and a CCD sensor 40 for receiving a ray of light reflected from the manuscript and converting it into an electrical signal. The fluorescent lamp 33 is connected to the control circuit 52 through a lighting device 47 for controlling a lighting. The output FLON of the control circuit 52 is connected to the input of the lighting device 47. The output of the lighting device 47 is connected to the input of the fluorescent lamp 33. When the FLON turns to "1", the fluorescent lamp 33 is put on. On the other hand, the CCD sensor 40 is connected to the input of a buffer 41 through the capacitor C, and a 5 V electric power source is connected to the input of the buffer 41 through the analog switch. Because the black level of CCD signals is ordinarily approx. 4 V (varies between 3 V and 5 V with different CCDs), an output voltage value ADIN of the buffer 41 is adjusted accurately to 5 V under action of a clamp signal T_{CLAMP} . To the output of the buffer 41, a 12-bit first AD convertor 51 for the high-resolution mode and an 8-bit second AD convertor 42 for the high-speed mode are connected in parallel, while a reset pulse ϕ_R is inputted to the first AD convertor 51 and the second AD convertor 42. Also, to the output of the first AD convertor 51 and that of the second AD convertor 42, a data selector 53 for selecting an output from the first AD convertor 51 or the second AD convertor 42 and for sending it out to the control circuit 52 is connected.

Furthermore, to the control circuits **52**, a pulse motor drive circuit **46** for driving and controlling a pulse motor **38** is connected, and outputs T_{STEP} and FORWARD of the control circuit **52** are inputted to the pulse motor drive circuit **46**. On receiving one time of T_{STEP} pulse when FORWARD is "1", the pulse motor is rotated by the pulse motor drive circuit **46** in such a way that the optical unit **34** and the fluorescent lamp **33** advance by one step. Similarly, on receiving one time of T_{STEP} pulse when Forward is "0", the pulse motor is rotated in such a way that the optical unit **34** and the fluorescent lamp **33** reverse.

The control circuit **52** comprises an oscillator **44** and a clock generating circuit **45** connecting therewith. A basic clock t_0 to oscillated by the oscillator **44** and divided in frequency by the clock generating circuit **45**, so that various control pulses SH, ϕ_1 , ϕ_2 , ϕ_R and T_{CLAMP} are generated. Control pulses SH, ϕ_1 , ϕ_2 and ϕ_R are supplied to the CCD sensor **40**, and the control pulse T_{CLAMP} is supplied to the analog switch.

Incidentally, the first AD convertor **51** and second AD convertor **42** convert the portion of 5 V or less in their input ADIN with 12 bits or 8 bits. That is, in the case of 8-bit AD conversion.

$D_0, D_1 \dots D_7$ are equal to
 0, 0, . . . 0 for ADIN=5 V,
 1, 1, . . . 1 for ADIN=3 V, respectively;
 and in the case of 12-bit AD conversion,
 $D_0, D_1, \dots D_{11}$ are equal to
 0, 0, . . . 0 for ADIN=5 V,
 1, 1, . . . 1 for ADIN=1 V, respectively.

Also, the first AD convertor **51** and the second AD convertor **42** use the rising of ϕ_R as an AD clock. That is, the instantaneous level of the rising of ϕ_R in ADIN is AD-converted.

A 12-bit input A or input B is selected by the data selector **53**. For example, an input A is selected when a FINE signal sent from the control circuit **52** to the SEL terminal is "1" and an input B is selected when a Fine signal is "0". However, the lower 4 bits of an input B are forcibly grounded, the 8-bit output of the second AD convertor **42** is converted into the 12-bit signal, and the output of the second AD convertor **42** is connected to the upper 8 bits of the 12-bit input of the data selector **53**.

As shown in FIG. 6, the clock generating circuit **45** located in the control circuit **52** is provided with a 4-bit binary counter **602** for dividing an 80-MHz reference clock sent from the oscillator **44** in frequency, to which the 4-bit binary counter a data selector **603** is connected. When a FINE signal is "1" the output of the data selector **603** is $Y=T=Q'_B$ and its frequency is 20 MHz. When a FINE signal is "0", the output of the data selector **603** is $Y'=T=Q'_A$ and is frequency is 40 MHz. And, the 4-bit binary counter **604** for dividing an output T from the data selector **603** in frequency is connected to the data selector **603**, and a decoder **605** is connected to the binary counter **604**. Furthermore, a data selector **606** is connected to the decoder **605**. The output of the data selector **606** is $Y_2=\phi_R=T_4$ when a FINE signal is "1", and the output of the data selector **606** is $Y^2=\phi_R=T_2$ when a FINE signal is "0".

Also, an inverter **611** for inverting its output T_7 is connected to the output terminal Y_7 of the decoder **605**, and a frequency divider **607** for dividing its output into L/K in frequency is connected to the inverter **611**. When the frequency divider **607** has counted the rising of outputs from the inverter **611** 4096 times. T_R begin is to rise with that rising and keeps 5 V until T_R itself is reset to its inverted value. That is, this frequency divider **607** is a type of 1/4096

frequency divider. Incidentally, the number of elements N in the CCD sensor **40** is 4095 or less.

A D flip-flop **608** capable of setting and resetting is connected to the output terminal Y_0 of the decoder **605**, and the D flip-flop **608** is arranged to output control pulses ϕ_1 and ϕ_2 . A D flip-flop **609** capable of setting and resetting is connected to the output terminal Y_3 of the decoder **605**, and the D flip-flop **609** is arranged to output a start pulse SH. The D flip-flop **609** is also arranged to be reset by an output of the inverter **612** for inverting the output terminal Y_5 of the decoder **605**.

Then, the operation of the present embodiment shown in FIG. 1 will be described along the timing charts of FIGS. 7A to 8B. In the present embodiment, there are two operational modes and the operation in the high-resolution mode will be first described.

In the high-resolution mode, the FINE signal becomes "1". A basic clock t_0 is oscillated by the oscillator **44** and divided in frequency by the 4-bit binary counter **602**, whose output is sent to the data selector **603**. As shown in FIG. 8A, the output $Y'=T=Q'_B$ is issued in a frequency of 20 MHz by the data selector **603**. And, an output T from the data selector **603** is divided in frequency by the 4-bit binary counter **604**, whose output is outputted to the decoder **605**. Furthermore, an output from the binary counter **604** is decoded by the decoder **605** and outputs T_0-T_7 are outputted. Then, an output T_0 from the decoder **605** is inputted to the T input of the D flip-flop **608**, from which transfer pulse ϕ_1 and ϕ_2 are outputted as shown in FIGS. 7A and 8A.

Also, outputs T_2 and T_4 from the binary counter **604** are issued to the data selector **606**. When a FINE signal is "1". $Y^2=\phi_R=T_4$ holds and a reset pulse ϕ_R is outputted from the data selector **606**. On the other hand, an output T_0 from the decoder **605** is inputted to the T input of the D flip-flop **609** and an output T_5 from the decoder **605** is inverted by the inverter **612** and inputted to the D input of the D flip-flop **609** and a clock SH is outputted from the Q output of the D flip-flop **609** as shown in FIG. 8A, while an output T_6 of the decoder **604** is outputted as T_{CLAMP} as shown in FIGS. 7A and 8A. Furthermore, an output T_7 from the decoder **605** is inverted by the inverter **611** and sent to the frequency divider **607**. When the rising of outputs from the inverter **611** is counted 4096 times by the frequency divider **607**. T_R begins to rise and keep 5 V and T_R itself is reset to the inverted value.

As shown in FIG. 7A, an output CCD_{out} from the CCD sensor **40** is clamped to 5 V by the capacitor C and analog switch. The clamped signal is amplified by the buffer **41** and outputted as an ADIN signal as shown in FIG. 7A. The ADIN signal is converted into digital signal by the AD convertors **51** and **42**. Furthermore, digital signals $D_0, D_1, \dots D_{11}$ outputted from the first AD convertor **51** are inputted to the 12-bit input A of the data selector **53**, while digital signals $D_0, D_1, \dots D_7$ outputted from the second AD convertor **42** are inputted to the 12-bit input B of the data selector **53**. Then, in accordance with the FINE signal "1", the input A is selected by the data selector **53** and outputted to the control circuit **52**.

Next, the operation in the high-speed mode will be described.

If the clock period is simply halved in FIG. 7A. ϕ_R and CCD_{out} changed as indicated with dashed lines in FIG. 7B, so that the CCD black level in CCD_{out} cannot be stabilized. Thus by forwarding the position of ϕ_R as indicated with a solid line, the stabilized period is secured.

In the high-speed mode, the FINE signal becomes "0". As shown in FIG. 7B, the output CCD_{out} from the CCD sensor

40 is clamped to 5 V by the capacitor C and the analog switch. The clamped signal is amplified by the buffer 41 and outputted as an ADIN signal as shown in FIG. 7B. The ADIN signal is converted into digital signal by the AD convertors 51 and 42. Furthermore, digital signals D₀, D₁, . . . D₁₁ outputted from the first AD convertor 51 are inputted to the 12-bit input A of the data selector 53, while digital signals D₀, D₁, . . . D₇ outputted from the second AD convertor 42 are inputted to the 12-bit input B of the data selector 53. Then, in accordance with the FINE signal "0", the input B is selected by the data selector 53 and outputted to the control circuit 52.

Incidentally, as clearly seen from the timing chart of FIG. 7B, the timing for AD conversion is the time when the ADIN signal has just been settled in the high-resolution mode of FIG. 7A. At that time, the ADIN signal has still been unstable in the high-speed mode of FIG. 7B, but can be converted without error because of a lower accuracy of the 8-bit input in comparison with the 12-bit input in the high-resolution mode. It is important for a reader to accurately derive the black level, because this black level is a standard level for all operations.

As shown in FIG. 9, if both the CCD output CCD_{out} and the manuscript are dark, the CCD black level rapidly reaches to a stable level even after φ_R is added to it, but it takes much time to achieve stability if the manuscript is bright. This is because the response speed of the output buffer inside the CCD is not fast in comparison with an ideal speed. Consequently, in order to add T_{CLAMP} to the manuscript from a dark region to a bright region at a stable timing of the black level, the reset pulse φ_R indicated with a solid line in FIG. 7B should be used.

Many widely different embodiments of the present invention may be constructed without departing from the spirit and scope of the present invention. It should be understood that the present invention is not limited to the specific embodiment described in the specification, except as defined in the appended claims.

What is claimed is:

1. A reader having a high-resolution mode and a high speed mode, comprising:
 - a CCD sensor for converting a received light into an electrical analog signal;
 - a first AD convertor for converting the output along signal of said CCD sensor into a digital signal;
 - a second AD convertor for converting said output analog signal, the bit number of the output digital signal from said second AD convertor being less than that from said first digital signal;
 - selecting means for selecting one of the output digital signals of said first and said second AD convertors, the output digital signal from said first AD convertor corresponding to said high-resolution mode and the output digital signal from said second AD convertor corresponding to said high-speed period corresponds to said high-speed mode; and

control means for controlling a reading period of said CCD sensor, wherein a first reading period corresponds to said high-resolution mode and a second reading period corresponds to said high-speed mode.

2. The reader according to claim 1, wherein said first AD convertor performs an analog to digital conversion for a longer period than that of said second AD convertor.

3. The reader according to claim 1, wherein each of said first and said second AD convertors is arranged to convert an output of the CCD sensor within a predetermined course of time during the respective reading period, and

the ratio of said predetermined course of time to the reading period in said second AD convertor is shorter than that of said predetermined course of time to the reading period in said first AD convertor so as to secure a period for stabilizing the output signal level of the CCD sensor.

4. The reader according to claim 1, further comprises a buffer and an analog switch for clamping the output of said CCD sensor to a predetermined DC voltage supplied from a power source in accordance with a control signal from said control means.

5. The reader according to claim 1, wherein said control means includes an oscillator for generating a base clock signal and a clock generating circuit for generating a plurality of clock signals by dividing the base clock signal in frequency.

6. The reader according to claim 1, wherein said first AD convertor converts an analog signal into a digital signal of 12 bits, and said second AD convertor converts an analog signal into a digital signal of 8 bits.

7. A reader having a high-resolution mode and a high speed mode, comprising:

- a CCD sensor for converting a received light into an electrical analog signal;*
- a first AD convertor for converting the output analog signal of said CCD sensor into a digital signal;*
- a second AD convertor for converting said output analog signal, the bit number of the output digital signal from said second AD convertor being less than that from said first digital signal;*
- a selector for selecting one of the output digital signals of said first and second AD convertors, the output digital signal from said first AD convertor corresponding to said high-resolution mode and the output digital signal from said second AD convertor corresponding to said high-speed period corresponds to said high-speed mode; and*
- a control circuit for controlling a reading period of said CCD sensor, wherein a first reading period corresponds to said high-resolution mode and a second reading period corresponds to said high-speed mode.*

* * * * *