

[54] **SPRAY GUN**

[72] Inventor: **Josef Wagner**, Markdorferstr. 165,  
Friedrichshafen-Fischbach, Ger-  
many

[22] Filed: **April 16, 1971**

[21] Appl. No.: **134,634**

3,120,347	2/1964	Duke, Jr. ....	239/332
3,163,360	12/1964	McNich, Jr. et al. ....	239/332 X
3,462,082	8/1969	Everett .....	239/332
3,565,344	2/1971	Takei et al. ....	239/332
2,819,061	1/1958	Platou .....	184/24 X

*Primary Examiner*—Lloyd L. King  
*Attorney*—Hill, Sherman, Meroni, Gross & Simpson

[30] **Foreign Application Priority Data**

April 18, 1970 Germany .....P 20 18 789.7

[52] U.S. Cl. ....239/332, 239/350, 23/351,  
222/333

[51] Int. Cl. ....**B05b 9/04**

[58] Field of Search .....239/332, 351, 412; 222/333;  
184/24

[56] **References Cited**

**UNITED STATES PATENTS**

3,116,879 1/1964 Wagner .....239/332

[57] **ABSTRACT**

A spray gun, particularly useful for spraying paints, having an electric vibrator during a piston pump submerged in an oil bath which hydraulically drives a diaphragm pumping the medium to be sprayed to a spray nozzle and separating the medium from the piston pump. The quantity of the medium to be sprayed is adjusted by controlling the stroke of the piston.

**10 Claims, 1 Drawing Figure**

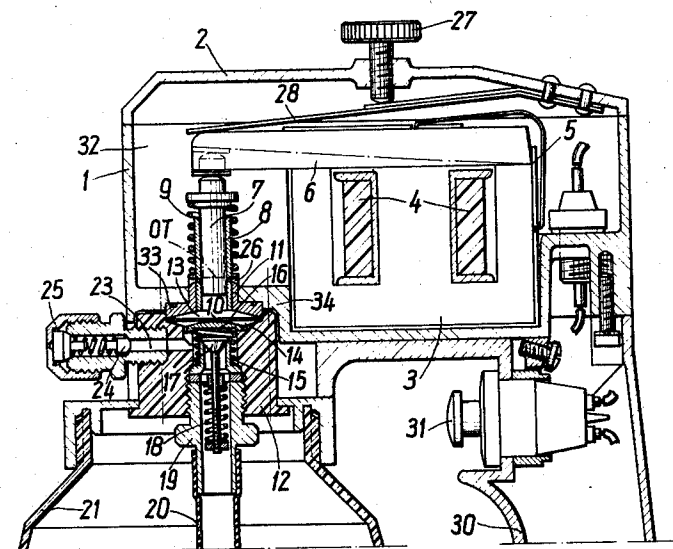

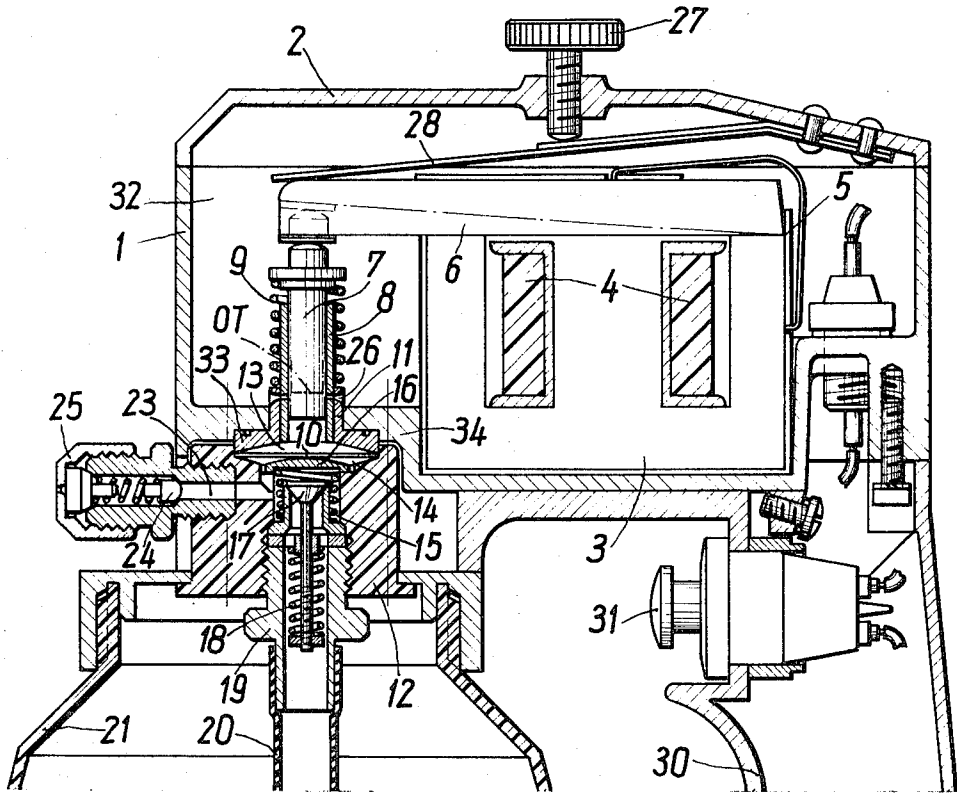

## SPRAY GUN

### BACKGROUND OF THE INVENTION

#### 1. Field of the Invention

This invention relates to a portable spray gun for spraying liquids, such as paints, which has a hydraulic piston pump driven by an electric vibrator and in turn driving a diaphragm pump for the liquid to be sprayed and isolating the liquid from the piston pump. Specifically the invention deals with an electric vibrator driven paint spray gun having an oil sump defining head housing an electric vibrator and a piston pump that hydraulically drives a diaphragm pump receiving paint from a container suspended from the head and discharging to a spray nozzle with the spray rate controlled by adjusting the stroke of the vibrator with an adjusting screw carried by the head.

#### 2. Description of the Prior Art

Electric spray guns generally have a piston pump directly propelling the spray medium and exposed to this medium so that on the compression stroke the fluid to be sprayed tends to penetrate the gap between the piston and cylinder wall. Highly fluid spray liquids will tend to escape through the cylinder past the piston to the interior of the gun where they may possibly endanger the operational safety as, for example, when penetrating the electric motor. Thicker liquids to be sprayed, such as paints and varnishes, will deposit abrasive pigments on the piston and cylinder wall causing rapid wear and deterioration. To date no satisfactory sealing between the piston and cylinder wall is available that is capable of withstanding chemical and mechanical attack of the liquids being sprayed, particularly paints and varnishes. The leakage and wear problem is particularly acute in lightweight portable spray guns where in the piston pumps must be quite small and particularly sensitive to leakage and clogging.

### SUMMARY OF THE INVENTION

According to the present invention, the sealing and wear problems of prior known piston pump spray guns is eliminated by completely isolating the piston pump from the spray media. This is accomplished by pumping the spray media with a diaphragm exposed on one side to the spray media and on the opposite side to a hydraulic piston pump submerged in an oil sump and driven by an electric vibrator. On the suction stroke the diaphragm draws the spray media into a valved chamber on one side thereof. At the end of the suction stroke the chamber is closed to trap the spray medium therein. On the compression stroke the diaphragm propels the trapped medium to the spray nozzle. The opposite side of the diaphragm is propelled by oil from the sump trapped ahead of the piston. The piston is driven by the oscillating head of an electric vibrator and its stroke is adjusted by controlling the stroke of the vibrator head.

Since the diaphragm completely isolates the spray medium from the piston pump and since it has no wearable parts sliding on each other the desired operating safety and long life of the spray gun is assured even though the spray medium may contain highly abrasive material.

Since the delivery capacity of the diaphragm is a function of the stroke of the piston as well as the amount of oil trapped between the piston and the

diaphragm on the pressure stroke of the piston, leakage of such trapped oil is replenished through ports which, however, accommodate restricted backflow so that a reduced volume of trapped liquid can be established to permit a reduced stroke of the piston. The piston drives the diaphragm through the oil trapped between the piston and diaphragm, but uncovers the ports at its top dead center position so that leakage may be replenished to maintain a full oil charge ahead of the piston on its pressure stroke when the stroke is maintained constant. When the stroke is lessened, however, the excess trapped oil may be relieved through these ports. The port passages converge toward the interior of the cylinder in a manner to accommodate flow into the cylinder while restricting flow out of the cylinder.

A feature of the invention includes the provision of an oil sump in the head of the spray gun which houses the electric vibrator motor and the piston pump. Since the diaphragm pump is relatively free from wearable parts, its body may be made of plastic and secured to the bottom of the head with the diaphragm clamped in position and the entire assembly secured to the head by screws. The body of the piston pump is preferably held by a flange clamped between the bottom of the head and the body of the diaphragm pump so that both pump bodies are removable as a unit from the pump head. The diaphragm body carries an inlet valve receiving the pumping media from a container suspended from the head and also mounts the outlet nozzle carrying an outlet valve.

It is then an object of this invention to provide an inexpensive lightweight portable spray gun having a head defining an oil sump and mounting an electric vibrator motor and a hydraulic piston pump driven by the motor which in turn drives a diaphragm pump suspended from the head and isolating the pumping media from the piston pump and oil sump.

Another object of this invention is to provide a lightweight portable paint spray gun with a piston pump which hydraulically drives a diaphragm pump separating the pumping media from the piston pump.

A further object of this invention is to provide an electric spray gun with a piston pump hydraulically driving a diaphragm pump for the spray media.

A specific object of the invention is to provide an electric spray gun having a hydraulic piston pump driven by an electric vibrator and in turn driving the diaphragm communicating on one side with the piston pump and on the other side with the spray media and having ports in the piston pump accommodating flow of hydraulic fluid ahead of the piston so that the stroke of the piston may be changed to vary the pumping rate of the diaphragm pump.

A specific object of this invention is to provide a lightweight inexpensive electric spray gun with a hollow head providing an oil sump and housing an electric vibrator motor and a piston pump driven thereby and suspending a diaphragm pump driven by the piston pump which effects the pumping of the spray media and having a cover closing the head carrying a screw control for regulating the stroke of the vibrating motor to thereby control the stroke of the piston pump.

Other and further objects of this invention will become apparent to those skilled in this art from the following detailed description of the annexed sheet of

drawings which by way of a preferred example illustrates one embodiment of the invention.

#### BRIEF DESCRIPTION OF THE DRAWING

The single FIG. 1 of the drawing is a vertical cross-sectional view, with parts in elevation, of the head portion of a spray gun of this invention and partially illustrating the handle of the gun and the container for the spray medial suspended from the head.

#### DESCRIPTION OF THE PREFERRED EMBODIMENT

The spray gun shown in the drawing includes a housing head 1 closed by a lid 2 and mounting an electric vibrator motor having a stator 3 with magnetic coils 4 and a pivot 5 for a vibrating head or oscillating armature 6. The armature 6 drives a piston pump with a piston 7 slidable in an upright cylinder 8 and biased against the armature 6 by a spring 9.

A diaphragm pump is suspended from the head 1 and includes a diaphragm 10 clamped between a bushing 11 and the pump body 12. The diaphragm 10 separates the chamber provided by the bushing 11 and the pump body 12 into an oil area or sump 13 and an underlying pumping chamber or area 14 for the spray media to be pumped.

A spring 15 in the pump body 12 biases a plate 16 against the underface of the diaphragm 10 to spring-load the diaphragm against the oil in the sump 13.

An inlet valve 17 biased to a closed position by a valve spring 18 is mounted under the diaphragm 10 and spring plate 16 being supported in the housing 12 by a threaded nipple 19 with a depending stud receiving the inlet tube 20 for the spray media. The tube 20 may communicate either with a separate paint container or, as shown, to a container 21 suspended under the housing head 1.

An outlet channel 23 communicates with the diaphragm or pumping area 14 and discharges through a valve 24 to the spray nozzle 25.

Channels or ports 26 are provided in the cylinder 8 of the piston pump to replenish oil which might leak out of the pump as well as to regulate the quantity of oil trapped ahead of the piston 7 when the stroke of the piston is changed. The cross-sectional area of the channels 26 is gradually tapered toward the interior of the cylinder 8 to provide for relatively free flow through the channels into the cylinder but to restrict or attenuate flow from this cylinder. The channels 26 are located at a level in the cylinder 8 so as to be uncovered at the upper dead center position OT of the piston 7.

The stroke of the piston 7 is adjusted by a set screw 27 threaded in the lid 2 and engaging a leaf spring 28 having one end anchored to the lid and the other end bottomed on the free end of the oscillating armature 6 above the piston. Threading of the screw 27 into the lid will load the leaf spring 28 more tightly against the oscillating head 6, thereby restricting its travel.

A handle 30 is suspended from the head 1 by means of screws or the like and carries a push-button 31 controlling current flow through electric conduits energizing the coil 4.

The entire interior area 32 of the housing 1 is filled with oil so that the cylinder 8 of the piston pump is completely immersed in oil.

The cylinder 8 of the piston pump is held in upright position in the housing 1 by the bushing 11 which has a flange 33 with one side bottomed on the floor 34 of the housing head and the other side bottomed on the pump body 12. Screws indicated at S secure the pump body to the floor 34 of the head 1 and clamp the diaphragm 10 between the pump body and the bushing flange 33. The bushing 11 in turn carries the cylinder 8. Thus, both the piston pump and the diaphragm pump form, together with the inlet valve 17, a unit secured to the bottom of the head 1 by the screws S which can be assembled or disassembled for service or replacement of parts. The pump body 12 may be composed of plastic.

#### OPERATION

During the downward movement of the piston 7 caused by the oscillating armature 6, the ports 26 of the sleeve 8 are first closed so that the oil ahead of the piston will act on the diaphragm 10 to drive the diaphragm downwardly against the spring biased plate 16. This downward movement of the diaphragm decreases the area 14 and propels the spray media therein to the nozzle 25 through the channel 23 and the valve 24.

During the subsequent upward movement of the piston 7 which is accomplished by the bias of the spring 9, the diaphragm 10 is urged upwardly by the spring biased plate 16 enlarging the pumping area 14 and creating a reduced pressure therein sufficient to open the inlet valve 17 against the spring load 18 and aspirating the spraying media into the pumping chamber 14 via the inlet tube 20.

If the upward stroke of the piston 7 is sufficient to uncover the ports 26 in the cylinder 8, oil will flow from the sump 32 to replenish any oil lost by leakage, for example, through the gap between the piston and cylinder during the preceding downward or pressure stroke so that with an unchained setting of the adjustment screw 27 a uniform delivery of the diaphragm pump is maintained.

If the delivery of the diaphragm pump is to be changed, for example increased, the set screw 27 is turned upwardly so that the upper dead center OT of the piston 7 will be at a higher level in the cylinder 8. This increases the area ahead of the piston so that during the upward movement of the piston oil is aspirated through the ports 26 from the oil sump 32. Due to the tapered design of the ports 26, the amount of oil flowing back to the sump during the subsequent pressure stroke of the piston 7 prior to the piston covering the ports 26 will be much smaller than the amount of oil previously aspirated into the cylinder. Thus, a greater volume of oil will be trapped ahead of the piston to fill the increased area provided by the increased stroke of the piston. This in turn increases the stroke of the diaphragm 10 and in turn increases the pumping rate of the diaphragm pump.

It will be understood from the above descriptions that this invention now provides an improved spray gun which completely separates the spraying media from the pumping mechanism and conveniently houses an electric motor driven piston pump in an oil sump provided by the head of the gun while suspending a diaphragm pump for the pumping media from this head.

I claim as my invention:

1. A spray gun which comprises a housing defining an oil sump, a hydraulic piston pump in said housing adapted to be immersed in and receive oil from said sump, an electric motor in said housing driving said pump, a diaphragm pump driven hydraulically from said piston pump, said diaphragm pump having an oil receiving chamber communicating with the piston pump and a pumping chamber communicating with the fluid medium to be sprayed, and said diaphragm separating said two areas to isolate the piston pump and oil sump from the pumping chamber media, and means for adjusting the stroke of the piston to control the quantity of the medium being sprayed.

2. A spray gun which comprises a head defining an oil sump, an electric oscillating motor in said head, a piston pump in said sump driven by said motor and adapted to be submerged in oil in the sump, a lid on said head, an adjusting screw carried by said lid controlling the stroke of said motor, a handle suspended from said head, a control switch carried by said handle for energizing said motor, a diaphragm pump suspended from said head having an inlet adapted to communicate with the medium to be sprayed, a spray nozzle receiving spray medium from said diaphragm pump, said diaphragm pump having an oil chamber communicating with oil from the piston pump and a pumping chamber communicating with the spray medium and with the outlet nozzle, an inlet valve controlling inflow to the pumping chamber, an outlet valve controlling outflow from the pumping chamber, said diaphragm isolating the oil from the spray medium, and ports in the piston pump replenishing oil from the sump to the oil chamber of the diaphragm pump.

3. A portable electric spray gun especially adapted for spraying paints, which comprises a hollow head defining an oil sump, an electric motor mounted in said head, a piston pump receiving oil from said oil sump driven by said electric motor, a handle depending from said head, a control switch carried by said handle controlling current flow to said electric motor in said head, a diaphragm pump suspended from said head having an oil chamber receiving oil from said piston pump and a pumping chamber, a container for spray media

suspended from said head communicating with said pumping chamber of said diaphragm pump, an inlet valve controlling flow from said container to said pumping chamber, a spray nozzle communicating with said pumping chamber, an outlet valve controlling flow from the pumping chamber to the spray nozzle, means for adjusting the stroke of said piston pump to control the quantity of spray medial pumped by said diaphragm pump, and means bleeding oil from said sump between the piston pump and diaphragm pump for replenishing oil leakage and for bleeding oil back to the sump to accommodate a change in stroke of the piston.

4. The spray gun of claim 1 including at least one oil intake port opening to the interior of the cylinder at the upper dead center position of the piston and converging toward the interior of the cylinder to restrict backflow from the cylinder to the sump.

5. The spray gun of claim 1 wherein the piston pump has an upright cylinder in the oil sump having converging ports accommodating flow of oil from the sump into the cylinder head of the piston and to accommodate flow of oil from the cylinder back to the sump at a higher attenuation rate than the inflow to the cylinder.

6. The spray gun of claim 1 wherein the piston pump has a spring biased piston engaging the oscillating armature of a vibrator motor in the housing.

7. The spray gun of claim 2 wherein the diaphragm pump body is composed of plastic and detachably secured to the bottom of the head by fastener screws.

8. The spray gun of claim 2 wherein the diaphragm of the diaphragm pump is clamped between a plastic pump body and a bushing supporting the cylinder of the piston pump.

9. The spray gun of claim 3 wherein the cylinder of the piston pump is supported by a bushing with a flange bottomed on the bottom of the head and held against said bottom by the body of the diaphragm pump whereby the pump bodies of both pumps are removable as a unit from the head.

10. The spray gun of claim 3 wherein the electric motor in the head is a vibrator with an oscillating armature, and a manual adjustment means engages said armature to control the stroke thereof.

\* \* \* \* \*

45

50

55

60

65